



晶采光電科技股份有限公司
AMPIRE CO., LTD.

SPECIFICATIONS FOR LCD MODULE

CUSTOMER	
CUSTOMER PART NO.	
AMPIRE PART NO.	AG-240128C (Controller)
APPROVED BY	
DATE	

AMPIRE CO., LTD.

**TOWER A, 4F, No.114, Sec. 1, HSIN-TAI 5th RD., HIS-CHIH,
TAIPEI HSIEN, TAIWAN(R.O.C.)**

台北縣汐止鎮新台五路一段114號4樓(東方科學園區A棟)

TEL:886-2-26967269, FAX:886-2-26967196 or 886-2-26967270

APPROVED BY	CHECKED BY	ORGANIZED BY

RECORD OF REVISION

Revision Date	Page	Contents
1999/11/22	-	New Release
2000/10/6	11	Add power on / off sequence
	12	Modify sampling plan
2001/10/2	3	Correct the mistake that AG-240128G became AG-240128C.
	4	Correct the mistake of mechanical data from 114 x 104 x 15 to become 144 x 104 x 15.
2001/12/12		Modify LED characteristic

1 FEATURES

- (1) Display format : 240 × 128 dot-matrix ; 1/ 128 duty.
- (2) Construction : STN/FSTN LCD, Bezel, Zebra ,Heat Seal and PCB.
- (3) Optional LED / EL back-light.
- (4) Built in controller T6963C.
- (5) 5V single power input. Built-in DC/DC converter for LCD driving.
- (6) Normal / Extended temperature type.

2 NUMBERING SYSTEM

AG-240128C -
 1 2 3 4 5

No	Code Value	Description	Remark
1	G	STN gray type LCD	LCD Type
	Y	STN yellow green type LCD	
	S	STN negative type LCD	
	F	FSTN type LCD	
2	A	Reflective type / 6:00 view	Polarizer / Viewing Angel
	B	Reflective type / 12:00 view	
	I	Transflective type / 6:00 view	
	J	Transflective type / 12:00 view	
	T	Negative type / 6:00 view	
	U	Negative type / 12:00 view	
3	None	Without backlight	Backlight type
	L	5V LED	
	E	EL	
4	None	Without backlight	Backlight color
	Y	Yellow-green	
	B	Blue	
	W	White	
5	None	Normal temperature type	LCM temperature type
	H	Extended temperature type	

3 MECHANICAL DATA

Parameter	Standard Value	Unit
Dot size	0.40 (W) × 0.40(H)	mm
Dot pitch	0.45(W) × 0.45(H)	mm
Viewing area	114.0(W) × 64.0(H)	mm
Module size (None/EL)	144.0(W) × 104.0(H) × 12.0 max (T)	mm
Module size (LED back-light)	144.0(W) × 104.0(H) × 15.0 max (T)	mm

4 ABSOLUTE MAXIMUM RATINGS

Parameter		Symbol	Min	Max	Unit
Logic Circuit Supply Voltage		VDD-VSS	0	7.0	V
LCD Driving Voltage		VDD-VO	0	26	V
Input Voltage		V _I	VSS	VDD	V
Normal temp. type	Operating Temp.	TOP	0	50	°C
	Storage Temp.	TSTG	-20	70	°C
Extended temp. type	Operating Temp.	TOP	-20	70	°C
	Storage Temp.	TSTG	-30	80	°C

5 ELECTRICAL CHARACTERISTICS

Parameter	Symbol	Condition	Min	Typ	Max	Unit	Note
----- Electronic Characteristics -----							
Logic Circuit Supply Voltage	VDD-VSS	--	4.75	5.0	5.25	V	
LCD Driving Voltage	VDD-VO	-20 °C	20.0	21.0	22.0	V	0 ~ 50 °C for Normal Temp. type -20 ~ 70 °C for Extended Temp. type
		0 °C	19.0	20.0	21.0		
		25 °C	18.0	18.9	19.8		
		50 °C	17.1	18.0	18.9		
		70 °C	16.0	17.0	18.0		
Input Voltage	VIH	--	0.7 VDD	--	VDD	V	
	VIL	--	VSS	--	0.3 VDD	V	
Logic Supply Current	IDD	VDD = 5V	--	25	--	mA	
----- Optical Characteristics -----							
Contrast	CR	STN type	--	5	--		Note 1
		FSTN type	--	8	--		
Rise Time	tr	25°C	--	170	255	ms	Note 2
Fall Time	tf	25°C	--	400	600	ms	
Viewing Angle Range	θ f	25°C & CR≥2	--	40	--	Deg.	Note 3
	θ b		--	35	--		
	θ l		--	40	--		
	θ r		--	40	--		
Frame Frequency	fF	25°C	--	64	--	Hz	
----- LED Back-light Characteristics -----							
Forward Voltage	VF	--	--	4.05	4.3	V	Supply Voltage between A&K
Forward Current	IF	VF=4.05V	--	1100	--	mA	
LCM Luminous intensity		VF=4.05V	--	30	--	cd/m ²	

* LED Dice number = 2x110=220

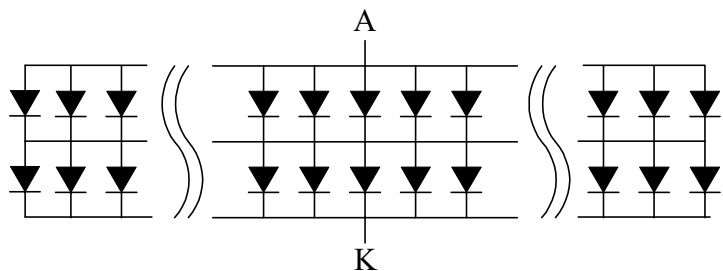

Parameter	Min	Typ	Max	Unit	Note
----- EL Back-light Characteristics -----					
Driving Voltage	--	110	--	Vrms	
Frequency	--	400	--	Hz	
LCM Luminous intensity	--	10	--	cd/m ²	

(NOTE 1) Contrast ratio :

$$CR = (\text{Brightness in OFF state}) / (\text{Brightness in ON state})$$

(NOTE 2) Response time :

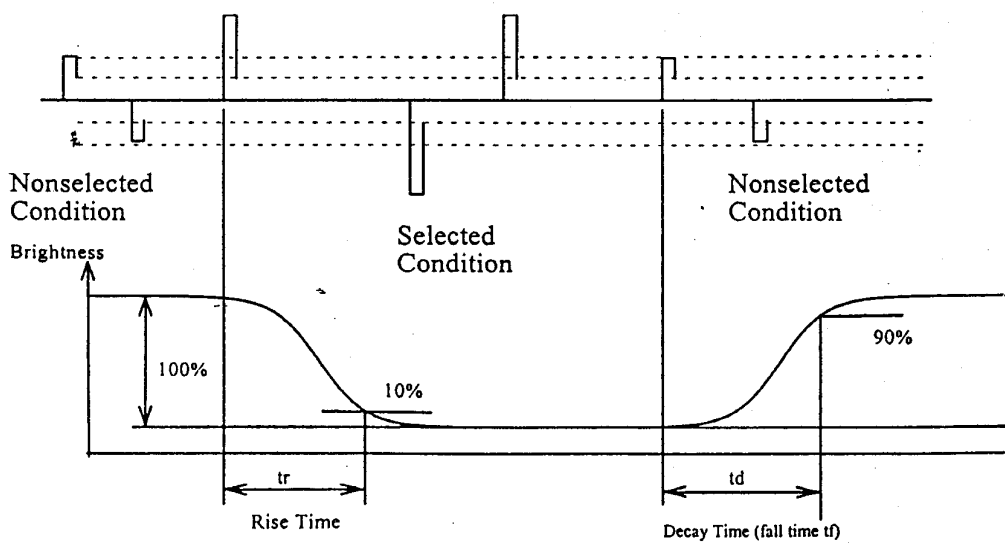

(NOTE 3) Viewing angle

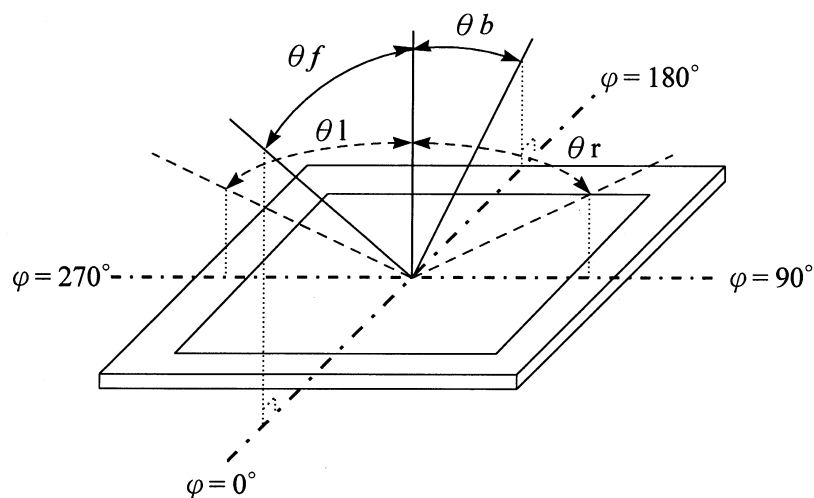

6 BLOCK DIAGRAM & POWER SUPPLY

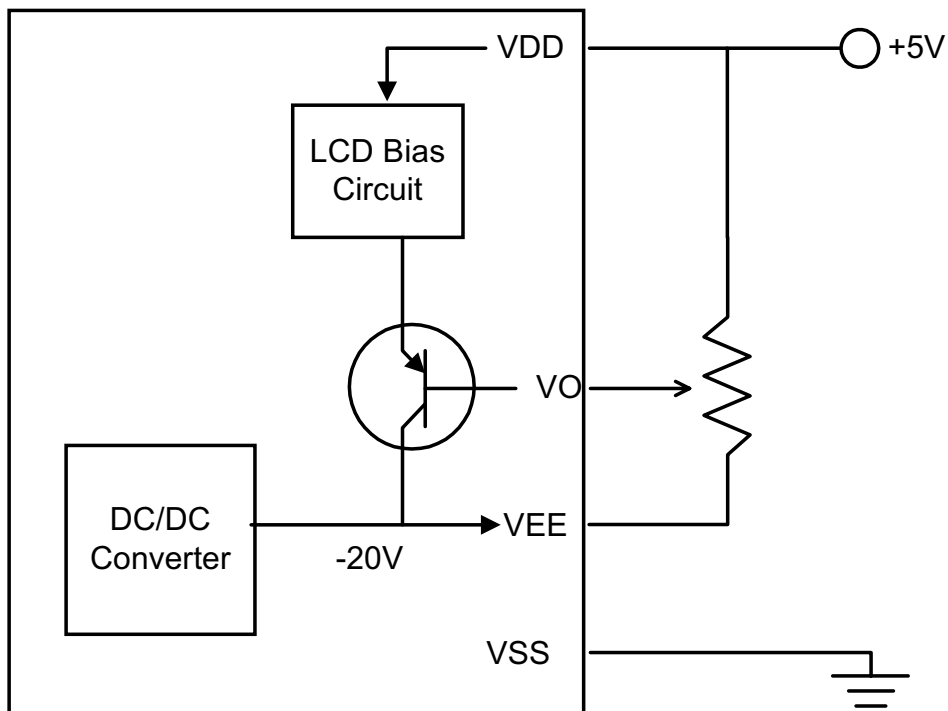
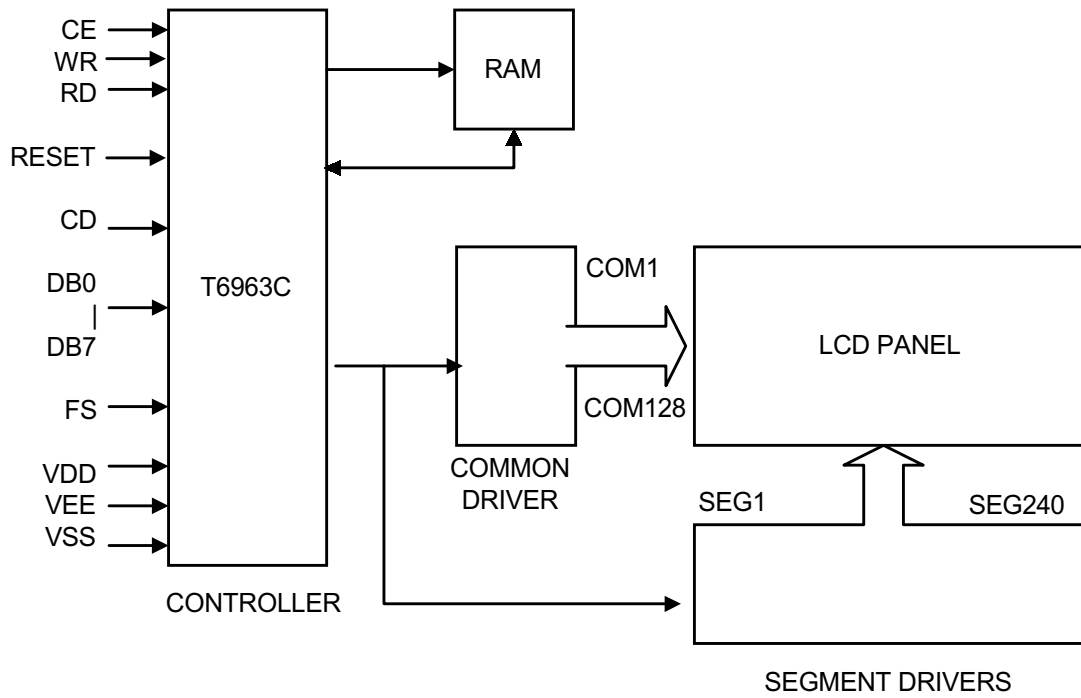

Using LED Back-light

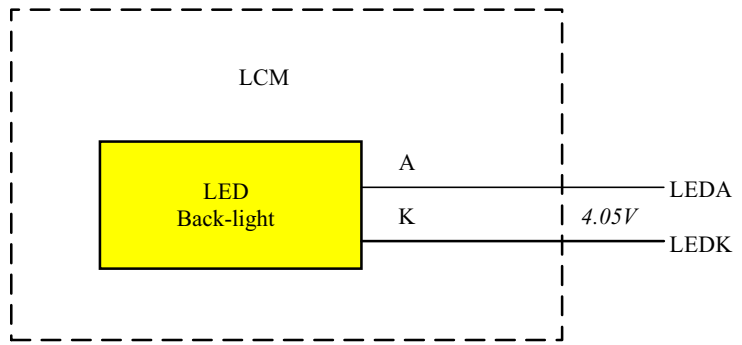

Using EL Back-light

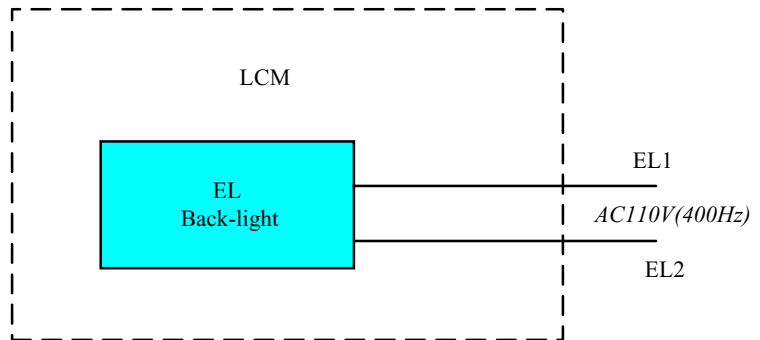

8 TIMING CHARACTERISTICS

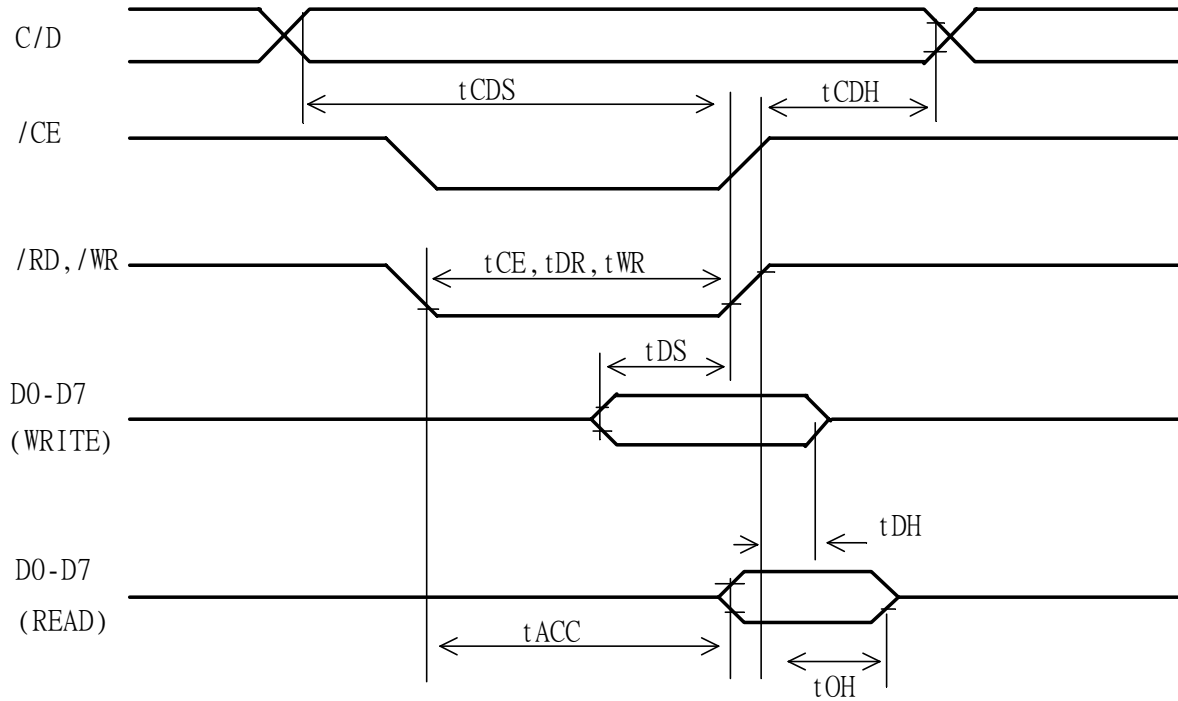

ITEM	SYMBOL	MIN	MAX	UNIT
C/D SET UP TIME	TCDS	100	--	ns
C/D HOLD TIME	THCL	10	--	ns
/CE,/RD,/WR PULSE WIDTH	TCE,TRD,TWR	80	--	ns
DATA SET UP TIME	TDS	80	--	ns
DATA HOLD TIME	TDH	40	--	ns
ACCESS TIME	TACC	--	150	ns
OUTPUT HOLD TIME	TOH	10	50	ns

8.1 Power ON/OFF Sequence

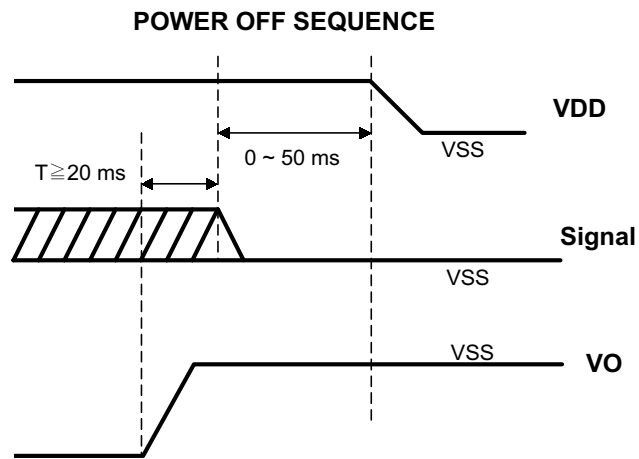
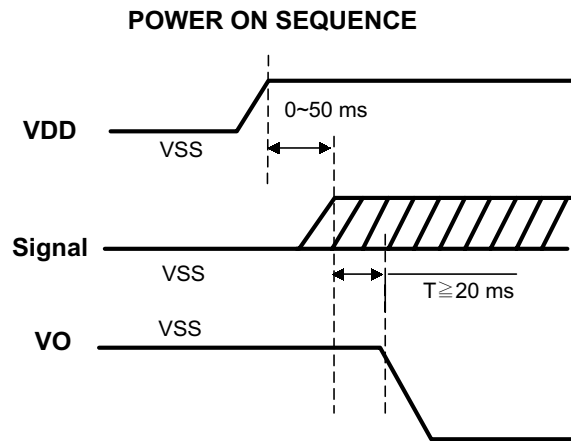

9 QUALITY AND RELIABILITY

9.1 TEST CONDITIONS

Tests should be conducted under the following conditions :

Ambient temperature : $25 \pm 5^{\circ}\text{C}$

Humidity : $60 \pm 25\% \text{ RH}$.

9.2 SAMPLING PLAN

Sampling method shall be in accordance with MIL-STD-105E , level II, normal single sampling plan .

9.3 ACCEPTABLE QUALITY LEVEL

A major defect is defined as one that could cause failure to or materially reduce the usability of the unit for its intended purpose. A minor defect is one that does not materially reduce the usability of the unit for its intended purpose or is an infringement from established standards and has no significant bearing on its effective use or operation.

9.4 APPEARANCE

An appearance test should be conducted by human sight at approximately 30 cm distance from the LCD module under fluorescent light. The inspection area of LCD panel shall be within the range of following limits.

9.5 INSPECTION QUALITY CRITERIA

Item	Description of defects			Class of Defects	Acceptable level (%)
Function	Short circuit or Pattern cut			Major	0.65
Dimension	Deviation from drawings			Major	1.5
Black spots	Ave . dia . D	area A	area B	Minor	2.5
	$D \leq 0.2$	Disregard			
	$0.2 < D \leq 0.3$	3	4		
	$0.3 < D \leq 0.4$	2	3		
	$0.4 < D$	0	1		
Black lines	Width W, Length L	A	B	Minor	2.5
	$W \leq 0.03$	disregard			
	$0.03 < W \leq 0.05$	3	4		
	$0.05 < W \leq 0.07, L \leq 3.0$	1	1		
	See line criteria				
Bubbles in polarizer	Average diameter D $0.2 < D < 0.5$ mm for N = 4 , D > 0.5 for N = 1			Minor	2.5
Color uniformity	Rainbow color or newton ring.			Minor	2.5
Glass Scratches	Obvious visible damage.			Minor	2.5
Contrast ratio	See note 1			Minor	2.5
Response time	See note 2			Minor	2.5
Viewing angle	See note 3			Minor	2.5

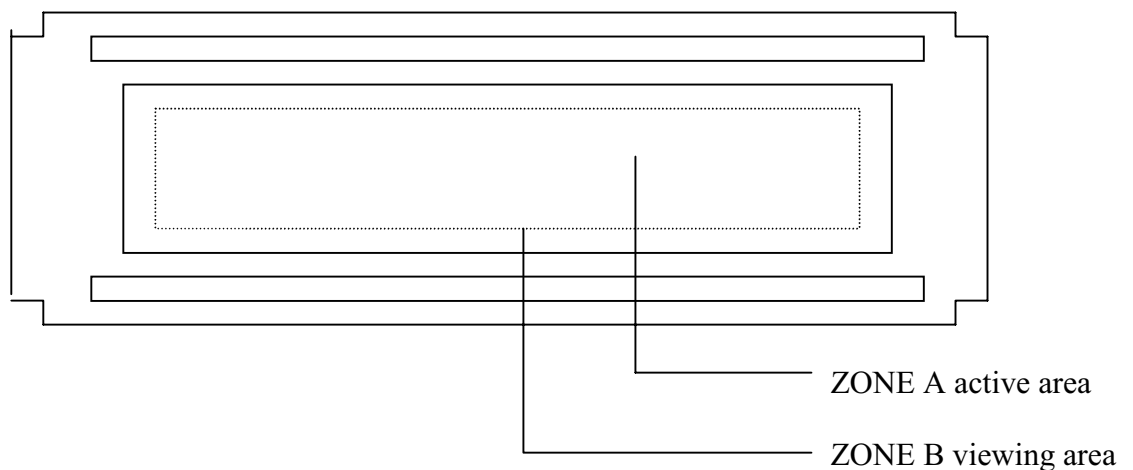

9.6 RELIABILITY

Test Item	Test Conditions		Note
	Normal Temp. type	Extended Temp. type	
High Temperature Operation	50±3°C , t=96 hrs	70±3°C , t=96 hrs	
Low Temperature Operation	0±3°C , t=96 hrs	-20±3°C , t=96 hrs	
High Temperature Storage	70±3°C , t=96 hrs	80±3°C , t=96 hrs	1,2
Low Temperature Storage	-20±3°C , t=96 hrs	-30±3°C , t=96 hrs	1,2
Temperature	-20°C ~ 25°C ~ 70°C 30 m in. 5 min. 30 min. (1 cycle) Total 5 cycle	-30°C ~ 25°C ~ 80°C 30 min. 5 min. 30 min. (1 cycle) Total 5 cycle	1,2
Humidity Test	40 °C, Humidity 90%, 96 hrs		1,2
Vibration Test (Packing)	Sweep frequency : 10 ~ 55 ~ 10 Hz/1min Amplitude : 0.75mm Test direction : X.Y.Z/3 axis Duration : 30min/each axis		2

Note 1 : Condensation of water is not permitted on the module.

Note 2 : The module should be inspected after 1 hour storage in normal conditions
(15-35°C , 45-65%RH).

Definitions of life end point :

- Current drain should be smaller than the specific value.
- Function of the module should be maintained.
- Appearance and display quality should not have degraded noticeably.
- Contrast ratio should be greater than 50% of the initial value.

10 HANDLING PRECAUTIONS

- (1) A LCD module is a fragile item and should not be subjected to strong mechanical shocks.
- (2) Avoid applying pressure to the module surface. This will distort the glass and cause a change in color.
- (3) Under no circumstances should the position of the bezel tabs or their shape be modified.
- (4) Do not modify the display PCB in either shape or positioning of components.
- (5) Do not modify or move location of the zebra or heat seal connectors.
- (6) The device should only be soldered to during interfacing. Modification to other areas of the board should not be carried out.
- (7) In the event of LCD breakage and resultant leakage of fluid do not inhale, ingest or make contact with the skin. If contact is made rinse immediately.
- (8) When cleaning the module use a soft damp cloth with a mild solvent, such as Isopropyl or Ethyl alcohol. The use of water, ketone or aromatic is not permitted.
- (9) Prior to initial power up input signals should not be applied.
- (10) Protect the module against static electricity and observe appropriate anti-static precautions.

