

## AEDS-964X

Small Optical Encoder Modules 150, 300, and 360 LPI Digital Output

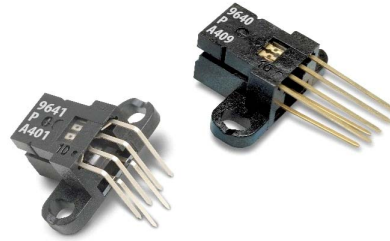

## Data Sheet



### Description

The AEDS-964X is a very small, low package height and high performance incremental encoder module. It can operate at supply voltage,  $V_{cc}$ , 3.3/5V and the output voltage,  $V_{oh}$ , will follow the  $V_{cc}$  voltage level.

When operated in conjunction with a codestrip, this module detects linear position. The encoder consists of lensed LED source and a detector IC enclosed in a small C-shaped plastic package. Due to the brighter LED, coupled with a photodetector array, which is less sensitive to light, the encoder is highly tolerant to aerosol environment. This module is extremely receptive to mounting misalignment.

The two channel digital outputs and  $V_{cc}$ , supply voltage input, are accessed through four solder plated leads located on 2.00mm (0.1 inch) centers. The supply input of LED, rated at 16mA is accessed through two leads located at 2.54mm.

It is designed for use with a linear codestrip/codewheel. Other options are available. Please contact the factory for more information.

### Features

- Small Size
- Built-in guide bumps for codewheel and codestrip
- Low Package Height
- Insensitive to Radial, Tangential and Axial Play
- 0°C to +70°C recommended operating temperature
- Wide Resolution Range
- Two Channel Quadrature Output
- TTL 3.3V or 5.0V CMOS compatible
- For Linear and Rotary Application
- Wave solderable
- RoHS Compliant

### Applications

- Printers
- Copiers/Fax
- Plotters
- Office Automation Equipments

## Theory of Operation

The AEDS-964X is a C-shaped emitter/detector module. Coupled with a codewheel, it translates rotary motion into a two-channel digital output; coupled with a codestrip, it translates linear motion into a two-channel digital output.

As seen in the Figure 1, the module contains a single Light Emitting Diode (LED) as its light source. The light is collimated into parallel beam by means of a single lens located directly over the LED. Opposite the emitter are the integrated detector circuits.

This IC consists of multiple sets of photodetectors and a signal processing circuitry necessary to produce the digital waveforms.

The codewheel/codestrip moves between the emitter and detector, causing the light beam to be interrupted by the pattern of spaces and bars on the codewheel/codestrip. The photodiodes that detect these interruptions are arranged in a pattern that corresponds to the radius and count density of the codewheel/codestrip.

These detectors are also spaced such that a light period on one pair of detectors corresponds to a dark period on the adjacent pairs of detectors. The photodiode outputs are fed through the signal processing circuitry.

Two comparators receive these signals and produce the final outputs for Channels A and B. Due to this integrated phasing technique the output of channel A is in quadrature with Channel B (90 degrees out of phase).

## Definitions

Note: Refer to Figure 1 for the output waveform

**Count (N):** The number of bar and window pairs or counts per revolution (CPR) of the codewheel. Or the number of lines per inch of the codestrip (LPI)

$$\begin{aligned} 1 \text{ shaft Rotation} &= 360 \text{ degrees} \\ &= N \text{ cycles} \end{aligned}$$

1 cycle (c) = 360 electrical degree, equivalent to 1 bar and window pair.

**Pulse Width (P):** The number of electrical degree that an output is high during one cycle. This value is nominally 180° e or 1/2 cycle.

**Pulse Width Error ( $\Delta P$ ):** The deviation, in electrical degrees, of the pulse width from its ideal value of 180° e.

**State Width (S):** The number of electrical degrees between a transition in the output of channel A and the neighboring transition in the output of channel B. There are 4 states per cycle, each nominally 90° e.

**State Width Error ( $\Delta S$ ):** The deviation, in electrical degrees of each state width from its ideal value of 90° e.

**Phase (f):** The number of electrical degrees between the center of the high state of channel A and the center of the high state of channel B.

**Phase Error ( $\Delta \phi$ ):** the deviation of the phase from its ideal value of 90°e.

**Direction of Rotation:** When the codewheel rotates in the counter clockwise direction (as viewed from the encoder end of the motor), channel A will lead channel B. If the codewheel rotates in the clockwise direction, channel B will lead channel A.

**Optical Radius (Rop):** The distance from the codewheel's center of the rotation to the optical center (O.C) of the encoder modules.

**Angular Misalignment Error (EA):** Angular misalignment of the sensor in relation to the tangential direction. This applies for both rotary and linear motion.

**Mounting Position (RM):** Distance from Motor Shaft center of rotation to center of Alignment Tab receiving hole.

### AEDS-964x Series Block Diagram

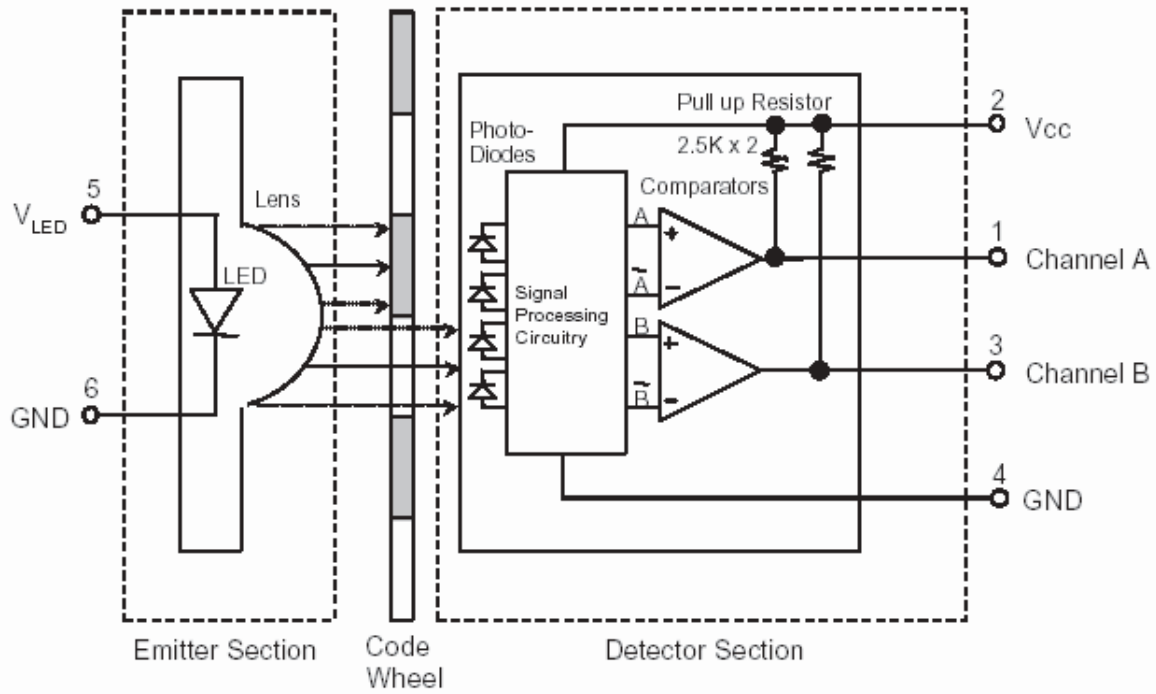

### Output Waveform

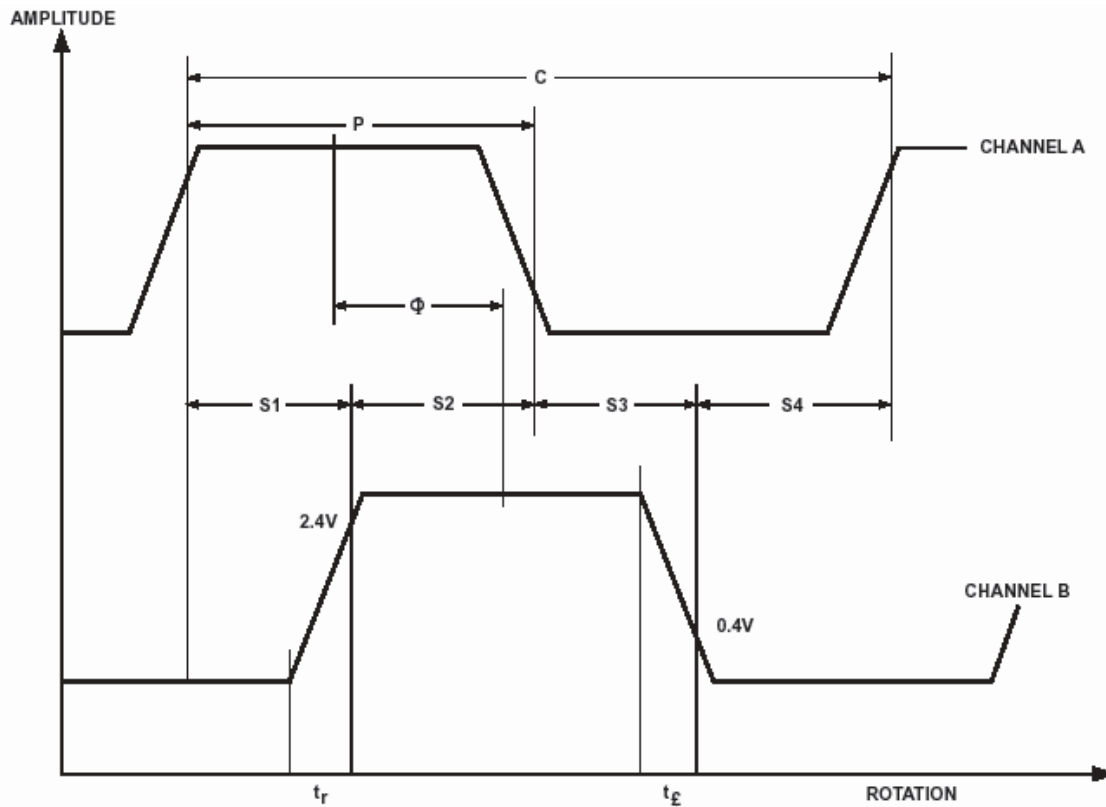

## Absolute Maximum Ratings

Parameter	Symbol	Min.	Max.	Units	Notes
Storage Temperature	$T_S$	-40	85	°C	
Operating Temperature	$T_A$	0	70	°C	
Supply Voltage (Detector)	$V_{CC}$	-0.5	7	Volts	
Output Voltage	$V_O$	-0.5	$V_{CC}$	V	
Output current per channel	$I_O$	-1.5	10	mA	Option P - 150 LPI
		-1.5	17	mA	Option 1 & 2 - 360 LPI
Soldering Temperature	$T_{SOL}$		260	°C	$t \leq 7$ sec
DC Forward	$I_{LED}$		40	mA	$V_F < 1.8V$
Reverse Voltage	$V_R$		5	V	$I_R = 100\mu A$

Subjecting the part to stresses beyond those listed under this section may cause permanent damage to the device. These are stress ratings only and do not imply that the devices function beyond these ratings. Exposure to the extremes of these conditions for extended periods may affect device reliability.

## Recommended Operating Conditions

Parameter	Symbol	Min.	Typ.	Max.	Units	Notes
Temperature	$T_A$	0	25	70	°C	
Supply Voltage (Detector)	$V_{CC}$	2.8	3.3 or 5.0	5.5	Volts	Ripple < 100mVpp
Load Capacitance	$C_L$			100	pF	
Pullup Resistor	$R_{pull}$		none		k	Recommended no pullup.
Count Frequency	$C_f$			60	kHz	Velocity (rpm) x N/60
Angular Misalignment	$E_A$	-3.0	0.0	+3.0	Deg.	Mounting consideration
Mounting Position	$R_M$		ROP - 2.4 (Rop-0.095")		mm (inch)	* Refer to mounting consideration
DC Forward Current (LED) @ $V_{CC} = 3.3$ V	$I_{LED}$	10	16	20	mA	Recommended 110 (±10%) series resistor between 3.3V supply and $V_{LED}$ .

## Electrical Characteristics

Electrical Characteristics over Recommend Operating Range, typical at 25°C

Parameter	Symbol	Min.	Typ.@ 3.3V	Max.	Units	Notes
Supply Current (Detector)	I <sub>CC</sub>	1.5	3.0	8	mA	
High Level Output Voltage	V <sub>OH</sub>					
Option P - 150 LPI		2.4	3.3	5.2	V	Typ. I <sub>OH</sub> = -0.7 mA @ 3.3 V
Option 1 & 2 - 300 & 360 LPI		2.4	3.3	5.2	V	Typ. I <sub>OH</sub> = -0.4 mA @ 3.3 V
Low Level Output Voltage	V <sub>OL</sub>					
Option P - 150 LPI				0.4	V	Typ. I <sub>OH</sub> = 8mA @ 3.3V
Option 1 & 2 - 300 & 360 LPI				0.4	V	Typ. I <sub>OH</sub> = 13mA @ 3.3V
Rise Time	t <sub>r</sub>		200		ns	C <sub>L</sub> = 25 pF
Fall Time	t <sub>f</sub>		50		ns	R <sub>L</sub> = 11 kΩ
LED Forward Voltage	V <sub>F</sub>	1.3	1.6	1.8	V	Typical I <sub>F</sub> = 16mA (turn on)

Note: Refer to Figure 2 for output waveform on tr and tf

## Encoding Characteristics

Encoding Characteristics over the Recommended Operating Conditions and Mounting Conditions. These characteristics do not include codewheel/codestrip contribution.

1. The typical values are average over the full rotation of the codewheel at Nominal Mounting Position and Typical Operating Conditions.
2. For a codestrip, the Typical Values are obtained at zero angular displacement and Typical Operating Conditions.

3. Maximums are the worst case values predicted over the full range of Recommended Mounting Tolerances and Operating Conditions, with consideration to population shift.

Parameter	Symbol	Typ.	Max.	Units
Pulse Width Error	ΔP	7	40	e
Logic State Width Error	ΔS	5	40	e
Phase Error	ΔΦ	2	20	e

## Mounting Configuration

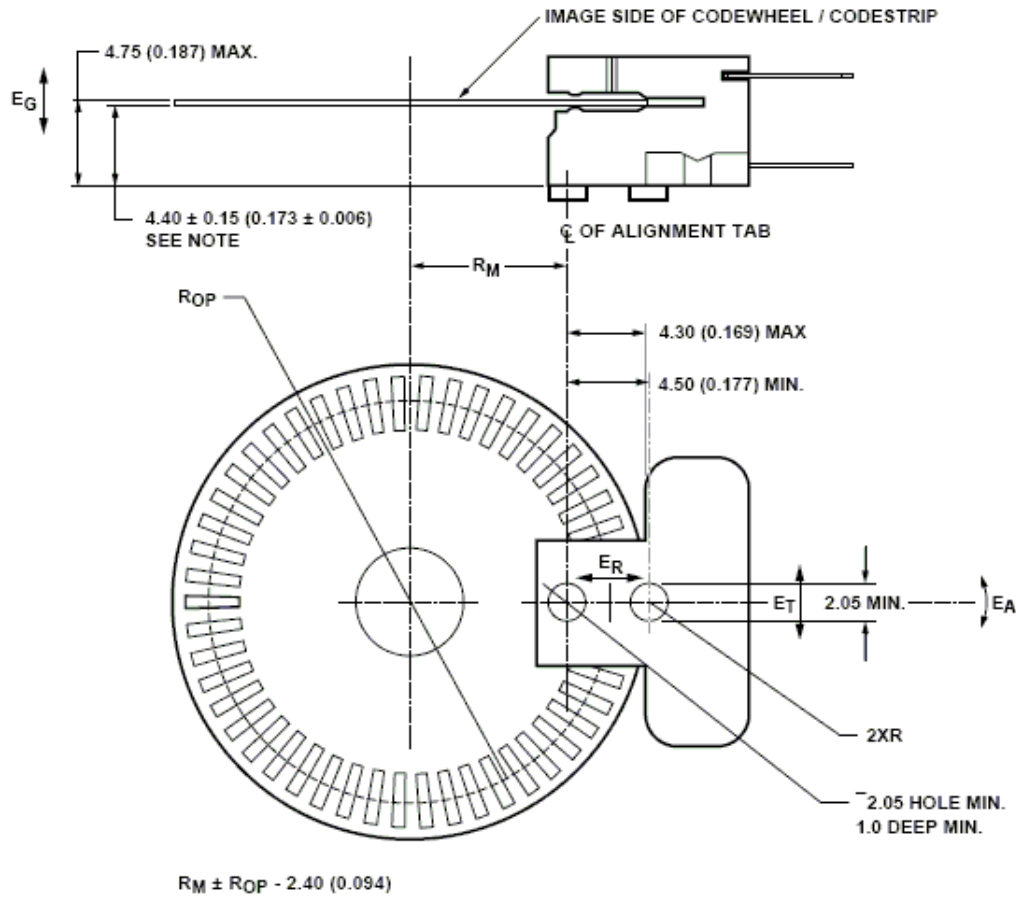

Note:

These dimensions include shaft end play and codewheel warp. All dimensions for mounting in the module and codewheel/codestrip should be measured with respect to the two mounting post shown above.

### For AEDS-964X-P10

Error		$R_{op}=11.00\text{mm}$	Unit	Notes
$E_g$	Gap	± 0.15	mm	Recommend CW to put closer to the detector side (upper side), in order to give enough margin for encoder operation.
$E_r$	Radial	± 0.13	mm	
$E_t$	Tangential	± 0.13	mm	
$E_a$	Angular	± 3	Deg.	

### For AEDS-964X-210 and AEDS-964X-110

Error		$R_{op}=23.36\text{mm}$	Unit	Notes
$E_g$	Gap	± 0.15	mm	Recommend CW to put closer to the detector side (upper side), in order to give enough margin for encoder operation.
$E_r$	Radial	± 0.26	mm	
$E_t$	Tangential	± 0.28	mm	
$E_a$	Angular	± 3	Deg.	

# Package Dimension

## AEDS-9640-X10 (Straight Lead)

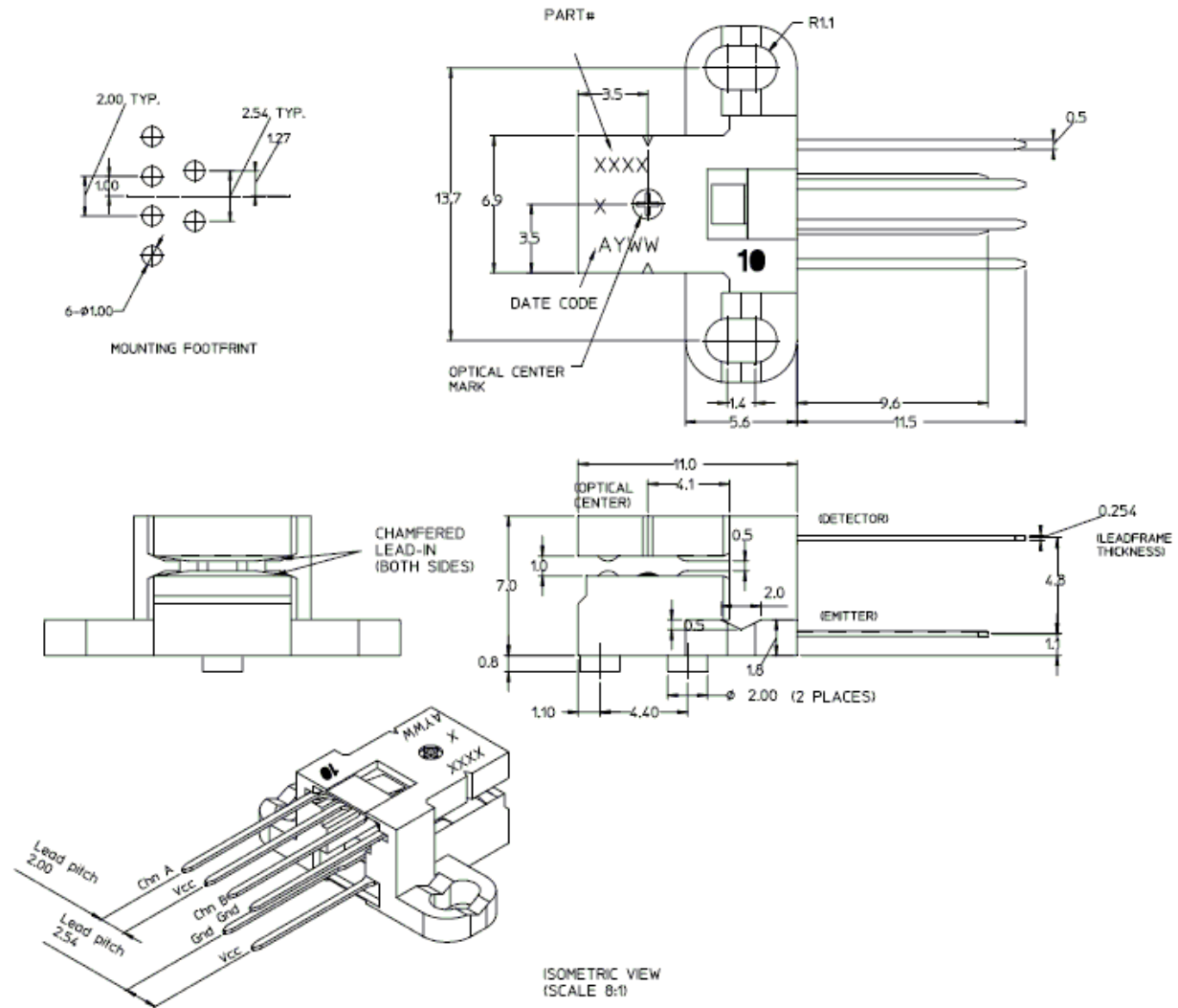

**AEDS-9641-X10 (Bent Lead)**

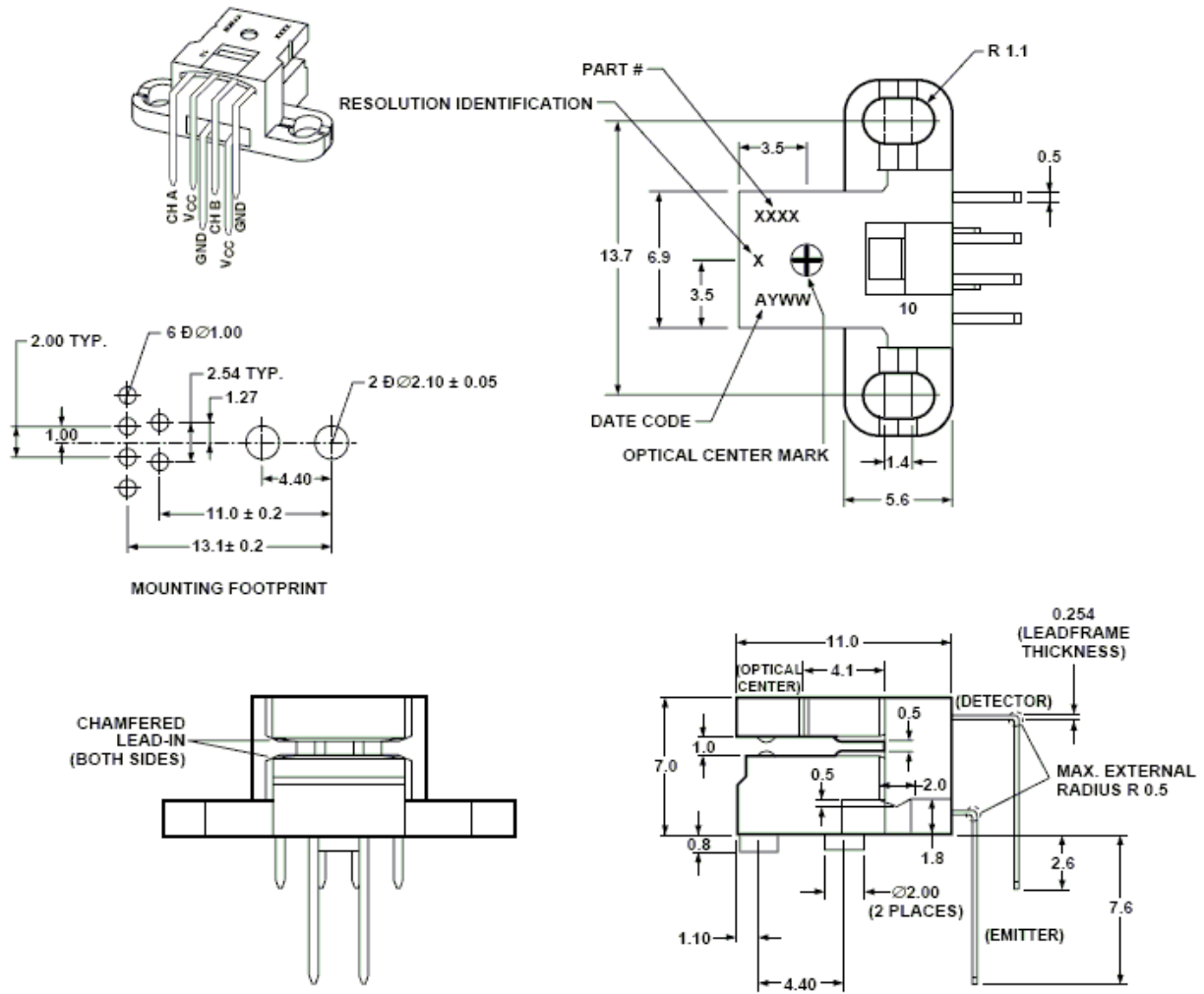



## Recommended Wave Solder Profile

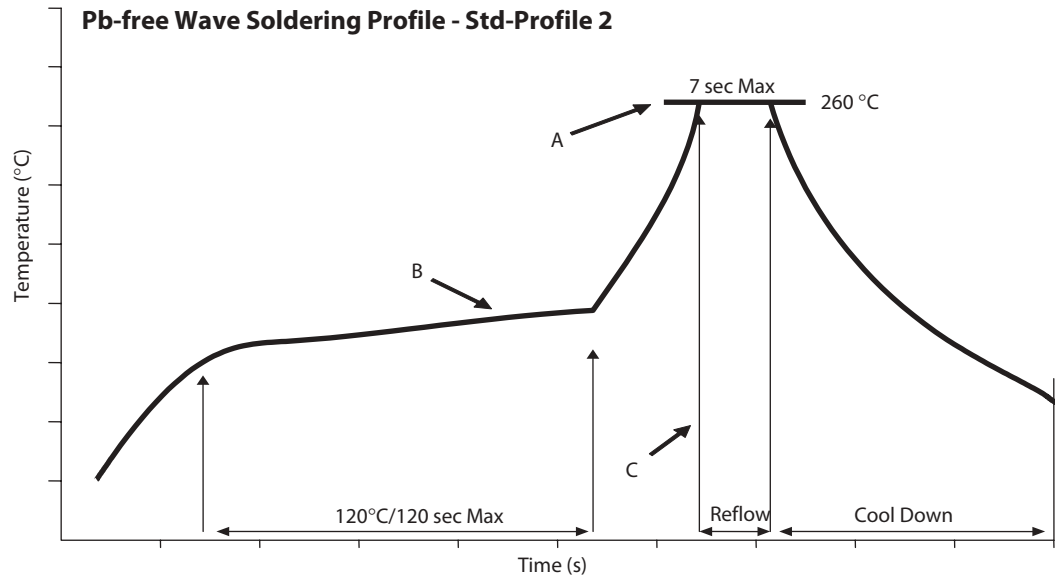

Parameter	Min.	Max.	Nominal values	Units
A Solder Pot Temperature	NA	260	250 - 260	°C
B Preheat Zone Temperature	85	120	100 - 120	°C
C Dip in Time	5	7	5	sec
D Solder Pot Zone (Encoder Lead)	200	260	NA	°C

**Note:**

- Nominal values are evaluated profiles for optimum performance.
- Min/Max are critical limits to ensure encoders in good condition.

## Ordering Information

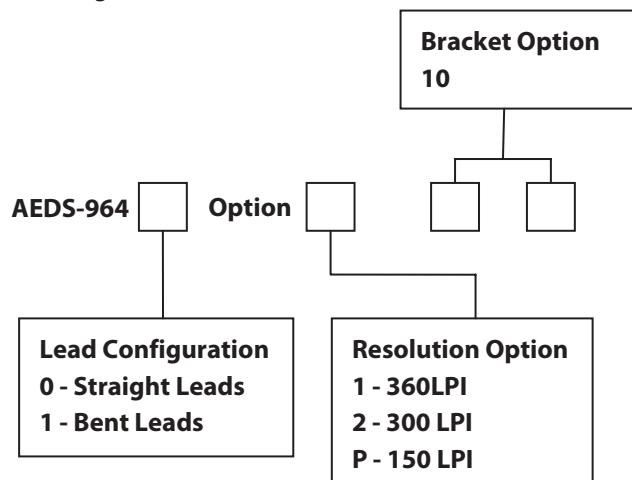

For product information and a complete list of distributors, please go to our web site: [www.avagotech.com](http://www.avagotech.com)

Avago, Avago Technologies, and the A logo are trademarks of Avago Technologies, Limited in the United States and other countries. Data subject to change. Copyright © 2006 Avago Technologies Pte. All rights reserved.  
AV01-0286EN - September 7, 2006

**Avago**  
TECHNOLOGIES