

DISPLAY ELEKTRONIK GMBH

DATA SHEET

LCD MODULE

DEM 128064B SYH-PY

Product specification

Version:4

24/03/2006

GENERAL SPECIFICATION

MODULE NO. :

DEM 128064B SYH-PY

CUSTOMER P/N

VERSION NO.	CHANGE DESCRIPTION	DATE
0	ORIGINAL VERSION	15.03.2004
1	CHANGE EXTERNAL DIMENSIONS	06.04.2004
2	CHANGED PCB DRAWING AND DESCRIPTION	05.07.2004
3	ADD VERSION	28.06.2005
4	MODIFY SPECIFICATION	24.03.2006

PREPARED BY : HZZ

DATE: 24.03.2006

APPROVED BY: MH

DATE: 24.03.2006

CONTENTS

1. FUNCTIONS & FEATURES -----4

2. MECHANICAL SPECIFICATIONS -----4

3. EXTERNAL DIMENSIONS-----4

4. BLOCK DIAGRAM -----5

5. PIN ASSIGNMENT -----5

6.1 PCB DRAWING AND DESCRIPTION -----6

6.2 EXAMPLE APPLICATION -----7

6.3 THE MODULE NO.IS PRINTED ON THE PCB-----7

7. ABSOLUTE MAXIMUM RATINGS -----8

8. POWER SUPPLY FOR LCD MODULE-----8

9. ELECTRICAL CHARACTERISTICS -----9

10. BACKLIGHT ELECTRICAL/OPTICAL SPECIFICATIONS ----- 11

11. OPERATING PRINCIPLES & METHODS----- 12

12. DISPLAY CONTROL INSTRUCTION ----- 15

13. LCD MODULES HANDLING PRECAUTIONS ----- 17

14. OTHERS ----- 17

1. FUNCTIONS & FEATURES

DEM 128064B SYH-PY:

MODULE	LCD MODE	LCD TYPE
DEM 128064B SYH-PY	STN Yellow Green	Transflective Positive Mode

- Viewing Direction : 6 O'clock
- Driving Scheme : 1/64 Duty Cycle, 1/9 Bias
- Power Supply Voltage : 5.0 Volt (typ.)
- Backlight Color : Yellow Green
- V_{LCD} Adjustable For Best Contrast : 12.9 Volt (typ.)
- Display contents : 128 x 64 Dots
- Interface RAM : 512 bytes (4096 bits)
- Interface : 8 bit parallel display data from MPU

2. MECHANICAL SPECIFICATIONS

- Module Size : 75.0 x 52.7 x 9.6 max.
- Dot Size : 0.40 x 0.40 mm
- Dot Pitch : 0.43 x 0.43 mm
- Dot Gap : 0.03 mm

3. EXTERNAL DIMENSIONS

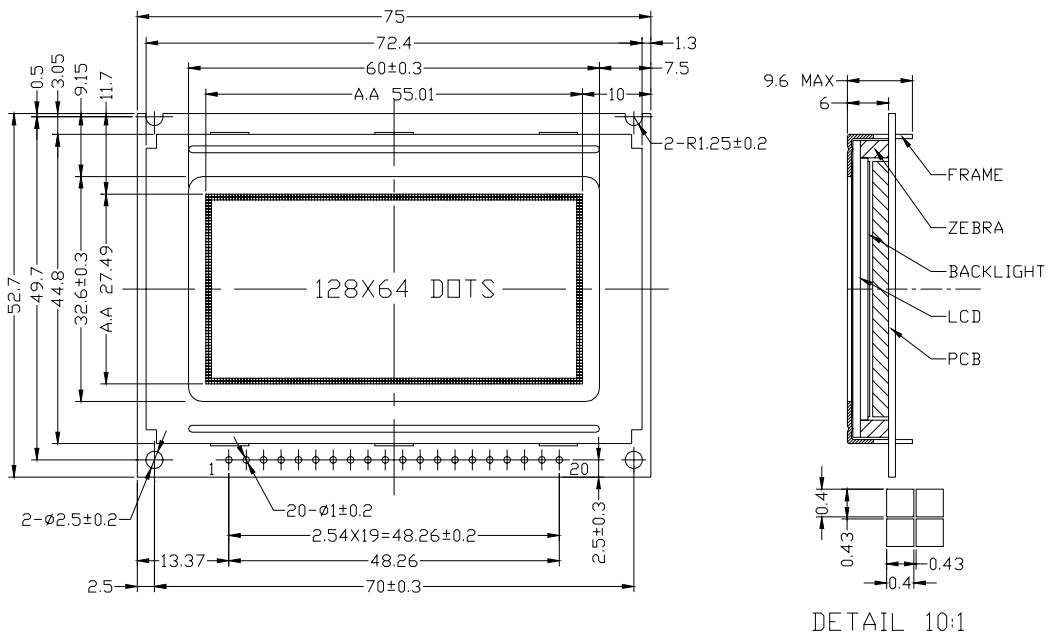

UNLISTED TOLERANCE IS ±0.5
THE MATERIAL IS LEAD-FREE.

4. BLOCK DIAGRAM

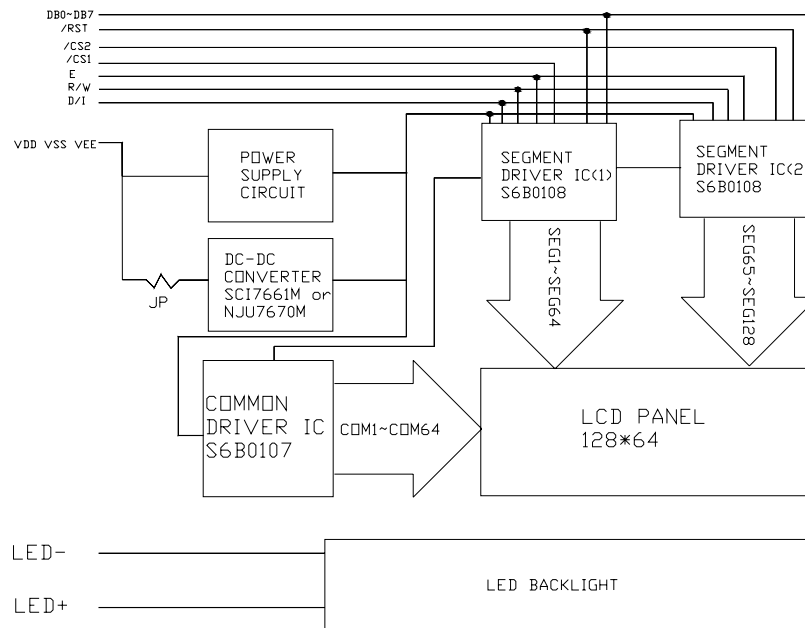

5. PIN ASSIGNMENT

Pin No.	Symbol	Function
1	VDD	POWER SUPPLY FOR LOGIC CIRCUIT
2	VSS	GND
3	V0	OPERATING VOLTAGE FOR LCD DRIVING
4	DB0	DATE BUS. Three state I/O port.
5	DB1	
6	DB2	
7	DB3	
8	DB4	
9	DB5	
10	DB6	
11	DB7	
12	CS1	Chip select signal for IC1
13	CS2	Chip select signal for IC2
14	/RST	Reset
15	R/W	H:DATA READ (LCM→MPU) L:DATA WRITE (LCM→MPU)
16	D/I	H:DATA INPUT;L:INSTRUCTION CODE INPUT
17	E	enable
18	VEE	POWER SUPPLY FOR LCD DRIVING
19	LED + (A)	Please refer to 6.1 drawing and description.
20	LED - (K)	

6.1PCB DRAWING AND DESCRIPTION

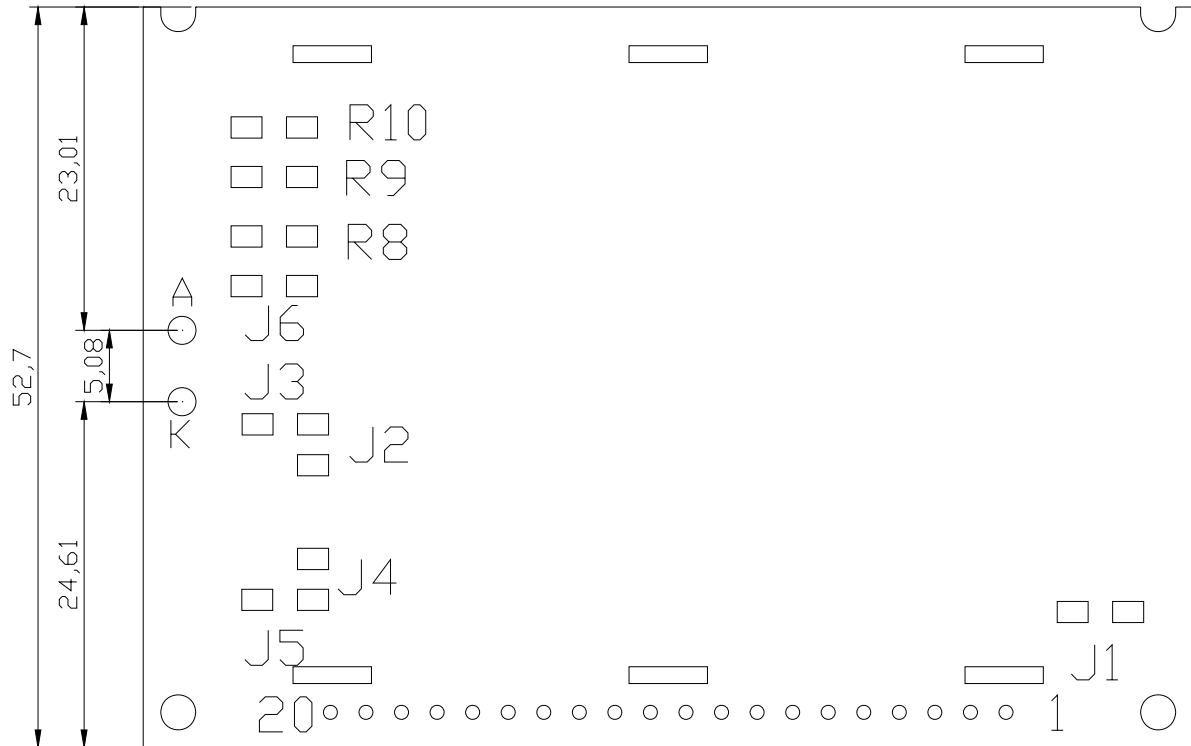

DESCRIPTION:

6-1-1.The polarity of the pin 19 and the pin 20:

Jumper Option	J3,J5	J2, J4	LED Polarity		Remark
			19 Pin	20 Pin	
Option 1	Each open	Each close	Anode	Cathode	Done by RCL
Option 2	Each close	Each open	Cathode	Anode	Done by RCL

Note: In application module, J3=J5=open, J2=J4=closed

6-1-2.The LED resistor can be bridged when the J6 is closed.

Note: In application module, J6=open

6-1-3.The R8, R9 and R10 are the LED resistor.

Note: R8=R9=R10=24Ohm

6-1-4. The metal-bezel is set on ground when the J1 is closed.

Note: In application module, J1=closed

6.2 Example application

6-2-1. The LED resistor should be bridged as following.

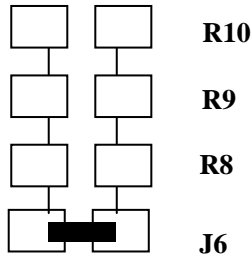

6-2-2. The 19 pin is the anode and the 20 pin is the cathode as following.

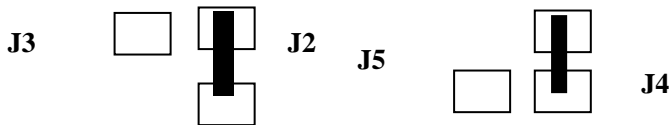

6-2-3. The 19 pin is the cathode and the 20 pin is the anode as following.

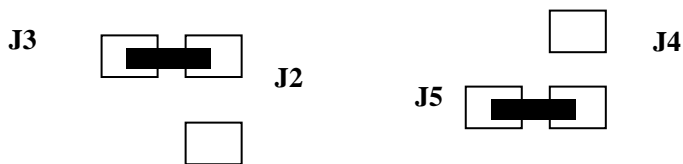

6-2-4. The metal-bezel is ground as following.



6.3 The module number DEM128064B is printed on the PCB.

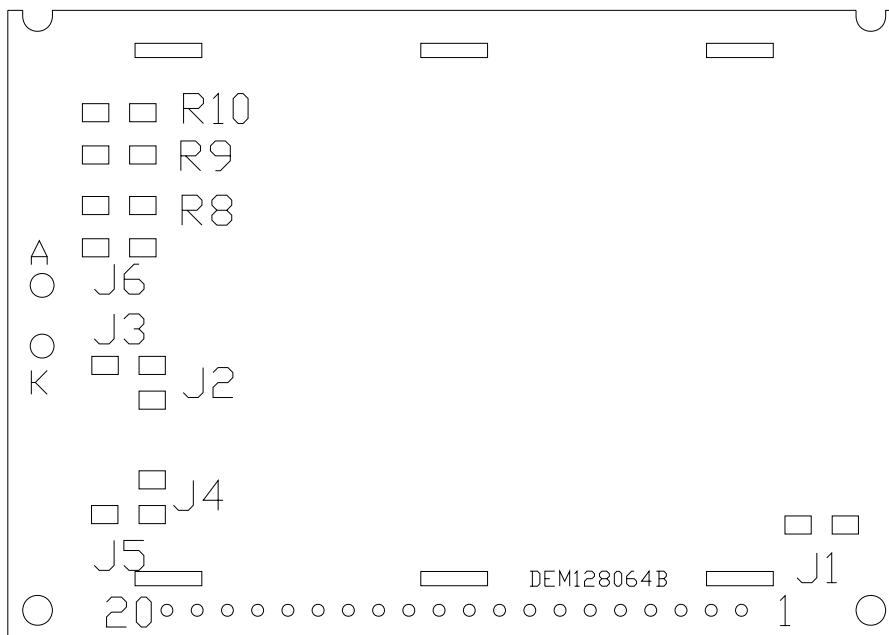

7. Absolute Maximum Ratings (Ta=25°C)

ITEM	SYMBOL	MIN.	TYP.	MAX.	UNIT
OPERATIONG TEMPERATURE	T _{OP}	-20	---	+70	°C
STORAGE TEMPERATURE	T _{ST}	-30	---	+80	°C
INPUT VOLTAGE	V _I	V _{SS}	---	V _{DD}	V
SUPPLY VOLTAGE FOR LOGIC	V _{DD} - V _{SS}	-0.3	---	7.0	V
SUPPLY VOLTAGE FOR LCD	V _{DD} - V ₀	-0.3	---	19.0	V
STATIC ELECTRICITY	Be sure that you are grounded when handing LCM				

8. POWER SUPPLY FOR LCD MODULE

8.1 External power supply circuit

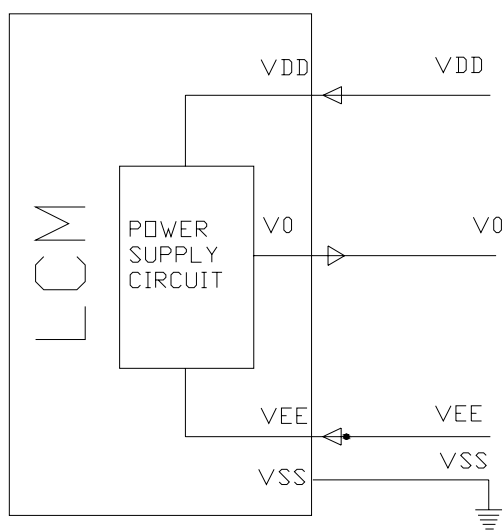

VDD-V0(V_{LCD}):LCD Driving voltage

8.2 Internal power supply circuit

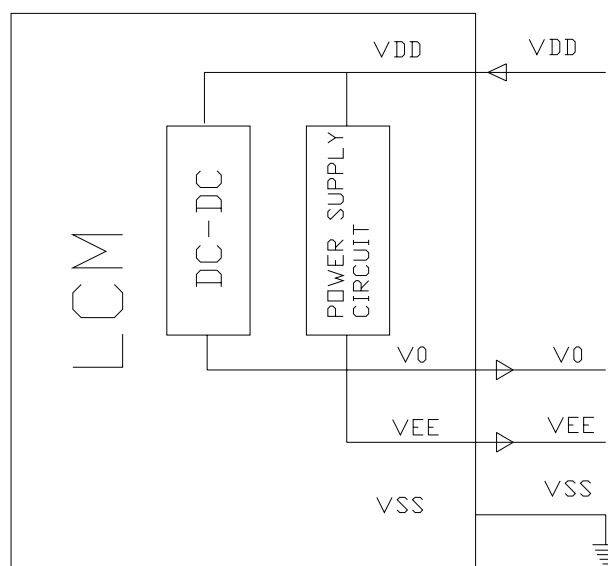

VDD-V0(V_{LCD}):LCD Driving voltage

9. ELECTRICAL CHARACTERISTICS

9-1 DC Characteristics(VDD=+5±10% V_{SS}=0V,Ta=-20~+70°C)

Item	Symbol	Standard Value			Test Condition	Unit
		MIN	TYP	MAX		
Supply current for logic	V _{DD}	4.5	5.0	5.5	-----	V
Supply current for logic	I _{DD}	----	2.62	4	-----	mA
operating Voltage for LCD	V _{DD} -V ₀	13.4	14.1	14.8	-20°C	V
		12.2	12.9	13.6	25°C	
		11.0	11.7	12.4	70°C	
Supply voltage for back light	V _F	---	4.2	4.6	-----	V
Supply current back light	I _F	---	380	500	V _F =4.2V	mA
Input voltage “H” level	V _{IH}	0.7V _{DD}	---	V _{DD}	---	V
Input voltage “L” level	V _{IL}	0	---	0.3V _{DD}	---	V

9-2 MPU Interface

Characteristic	Symbol	Min	Typ	Max	Unit
E Cycle	t _C	1000	-	-	ns
E Rise	t _R	-	-	25	ns
E Fall	t _F	-	-	25	ns
E High Level Width	t _{WH}	450	-	-	ns
E-Low Level Width	t _{WL}	450	-	-	ns
Address Set –Up Time	t _{ASU}	140	-	-	ns
Address Hold Time	t _{AH}	10	-	-	ns
Data Delay Time	t _D	-	-	320	ns
Data Set –Up Time	t _{DSU}	200	-	-	ns
Data Hold Time (Write)	t _{DHW}	10	-	-	ns
Data Hold Time (Read)	t _{DHR}	20	-	-	ns

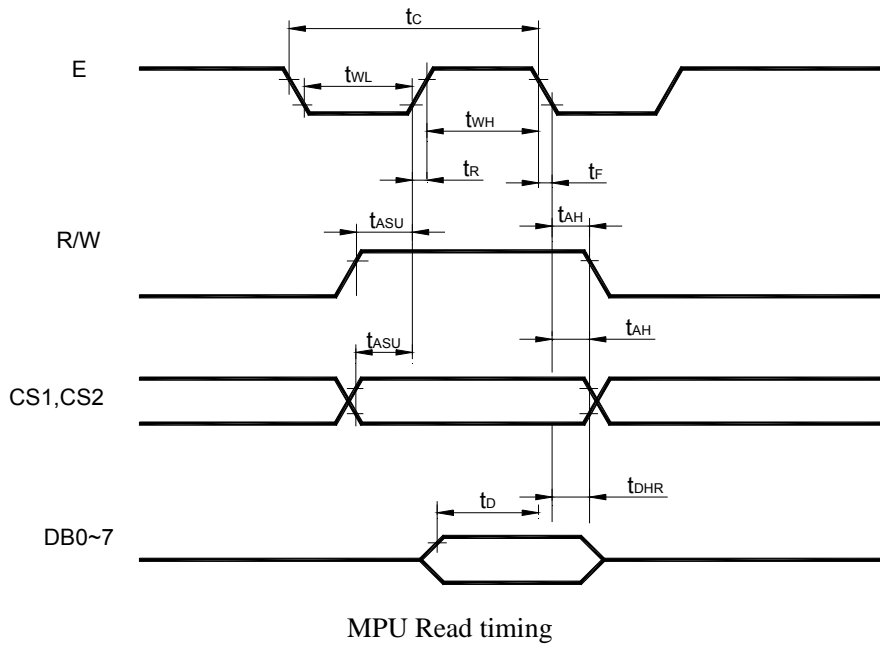
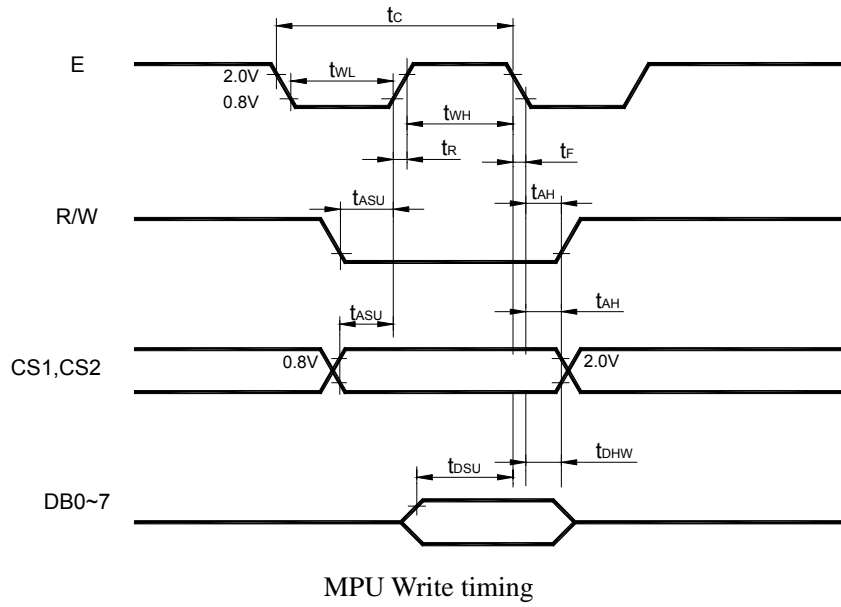

10. BACKLIGHT ELECTRICAL/OPTICAL SPECIFICATIONS

10.1 Data About LED Back light:

PARAMETER	SYMBOL	MIN.	TYP.	MAX.	Unit	TEST CONDITION	NOTE
Forward Voltage	V_F	4.1	4.25	4.4	V	$I_F=60mA$	---
Luminous Intensity	I_V	12	15	---	Cd/m ²	$I_F=60mA$	1(with LCD)
LED Peak Emission Wavelength	λP	570	574	578	Nm	$I_F=60mA$	---
Color	Yellow Green						

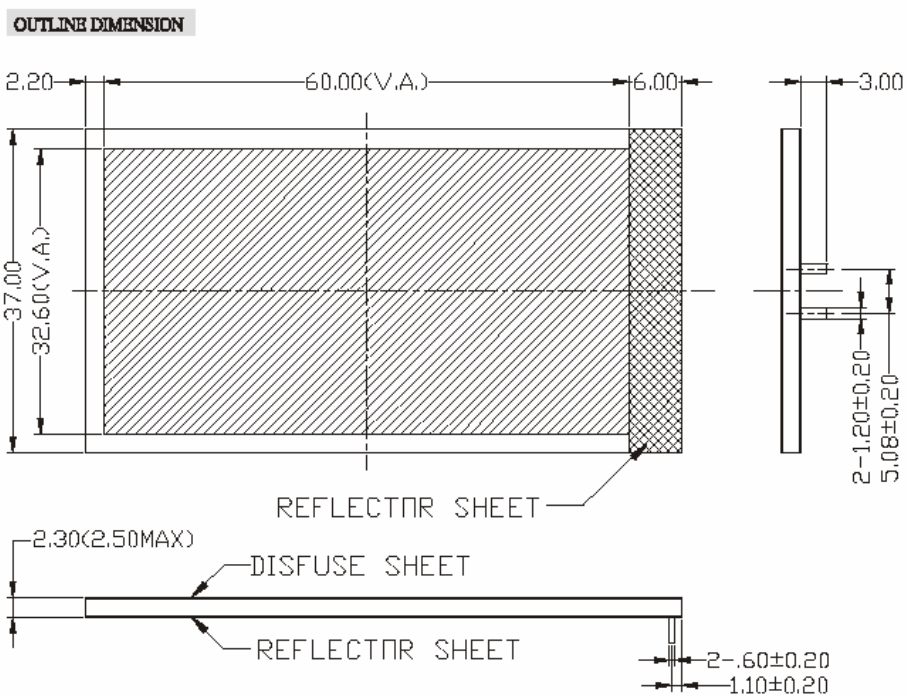

INTERNAL CIRCUIT

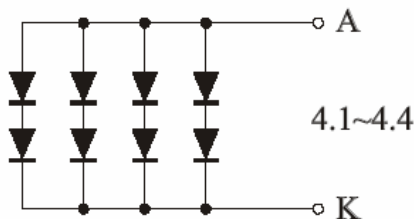

11. OPERATING PRINCIPLES & METHODS

11-1. I/O Buffer

Input buffer controls the status between the enable the and disable of chip. Unless the CS1 to CS2 is in active mode. Input or output of data and instruction does not execute. Therefore internal state is not change. Bust RSTB and ADC can operate regardless CS1-CS2.

11-2. Input register

Input register is provided to interface with MPU which is different operating frequency. Input register stores the data temporarily before writing it into display RAM. When CS1 to CS2 are in the active mode, R/W and RS select the input register. The data from MPU is written into input register. Then Writing it into display RAM. Data latched for the E signal and write automatically into the display data RAM by internal operation.

11-3. Output register

Output register stores the data temporarily from display data RAM when CS1 and CS2 are in active mode and R/W and RS=H, stored data in display data RAM is latched in output register. When CS1 to CS2 are in the active mode and R/W=H, RS=L, status data (busy check) can read out. To read the contents of display data RAM, twice access of read instruction needed. In first access, data in display data RAM is latched into output register. In second access, MPU can read data which is latched. That is , to read the data in display data RAM, it needs dummy read. But status read is not read needed dummy.

RS	R/W	Function
L	L	Instruction
	H	Status read (busy check)
H	L	Data write (from input read register to display data RAM)
	H	Data read (from display data RAM to output register)

11-4. Reset

The system can be initialized by setting RSTB terminal at low level when turning power on receiving instruction from RAM. When RSTB becomes low, following procedure is occurred.

1. Display off
2. Display start line register become set by 0. (Z-address 0)

While RSTB is low, No instruction except status read can be accepted. Therefore, execute other instructions after making sure than DB4=0 (clear RSTB) and DB7=0 (ready) by status read instruction.

The conditions of power supply data initial power up are shown in table 1.

Table 1. Power Supply Initial Conditions

Item	Symb	Min.	Typ.	Max.	Unit
Reset time	T _{RS}	1	-	-	us
Rise time	t _R	-	-	200	us

4.5[V]

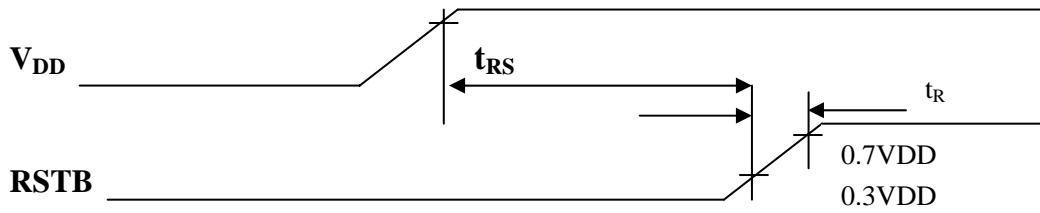

11-5. Busy flag

Busy flay indicates that S6B0108 is operating or on operating. When busy flag is high,S6B0108 is internal operating. When busy flag is low, S6B0108 can accept the data or instruction.

DB7 indicates busy flag of the S6B0108.

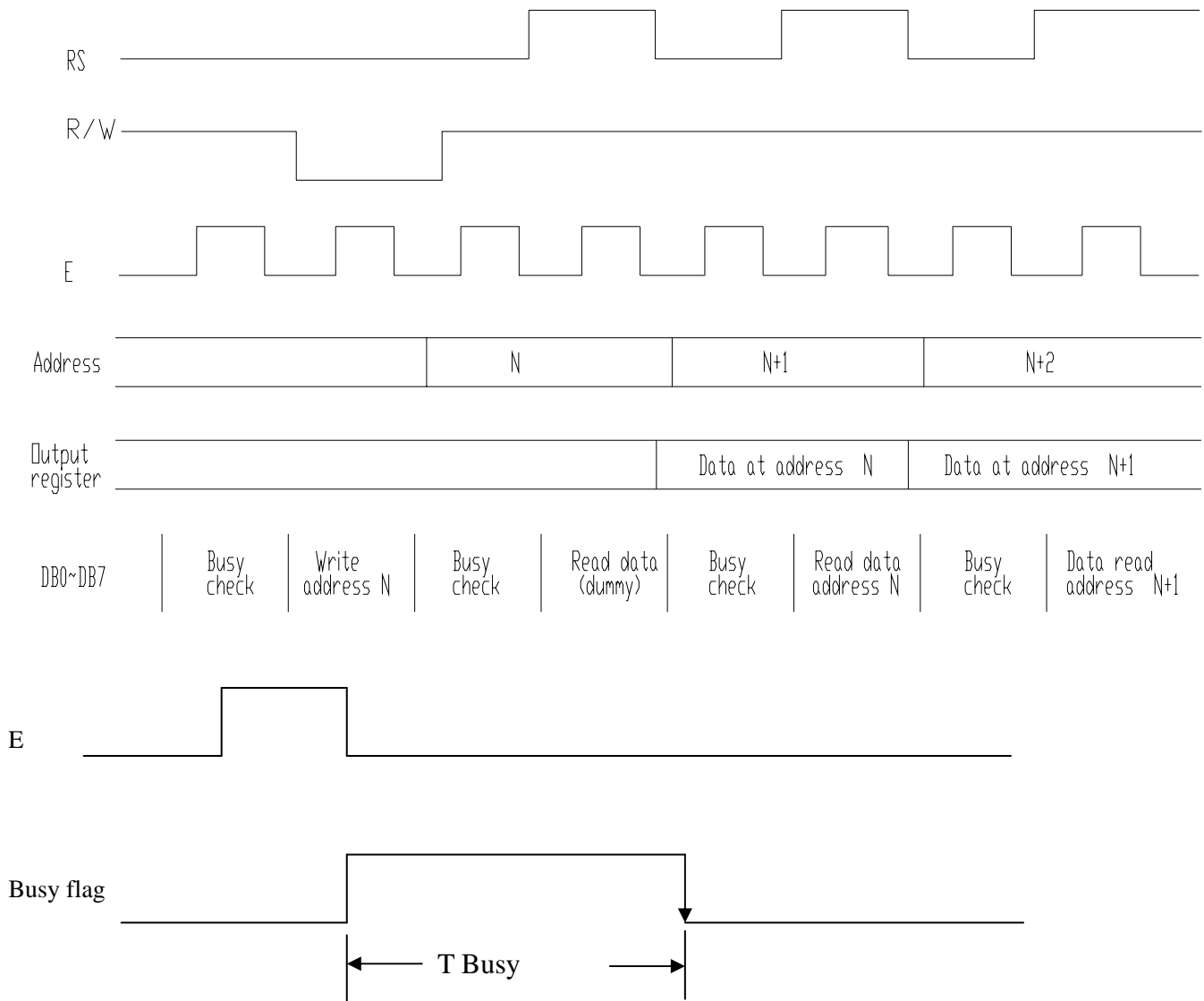

11-6. Display ON/OFF Flip-Flop

The display on/off flip-flop makes on/off the liquid crystal display. When flip-flop is reset (logical low), selective voltage or non selective voltage appears on segment output terminals. When flip-flop is set (logic high), non selective voltage appears on segment output terminals regardless of display RAM data. The display on/off flip-flop can changes status by instruction. The display data at all segment disappear while RSTB is low. The status of the flip-flop is output to DB5 by status read instruction.

11-7. X Page Register

X page register designates pages of the internal display data RAM. Count function is not available. An address is set by instruction.

11-8. Y address counter

Y address counter designates address of the internal data RAM. An address is set by instruction and is increased by 1 automatically by read or write operations of display data.

11-9. Display Data RAM

Display Data RAM stores a display data for liquid crystal display. To indicate on state dot matrix of liquid crystal display, write data 1. The other way , off state, writes 0.

11-10. Display Start Line Register

The display start line register indicates of display data RAM to display top liquid crystal display. Bit data (DB<0:5>) of the display start line set instruction is latched in display start line register. Latched data is transferred to the Z address counter while FRM is high, presetting the Z address counter. It is used for scrolling of the liquid crystal display screen.

12. DISPLAY CONTROL INSTRUCTION

The display control instructions the internal state of the S6B0108. Instruction is received from MPU to S6B0108 for the display control. The following table shows various instructions.

Instruction	RS	R/W	DB7	DB6	DB5	DB4	DB3	DB2	DB1	DB0	Function	
Display ON/OFF	L	L	L	L	H	H		H	H	L/H	Controls the display on or off. Internal status and display RAM data is not affected. L: OFF, H: ON	
Set Address (Y address)	L	L	L	H	Y address (0~63)						Sets the Y address in the Y address counter.	
Set Page (X address)	L	L	H	L	H	H	H	Page (0~7)			Sets the X address At the X address counter	
Display Start line (Z address)	L	L	H	H	Display start line (0~63)						Indicates the display data RAM displayed at the top of the screen.	
Status Read	L	H	B U S Y	L	O N / O F F	R E S E T	L	L	L	L	Read status BUSY L: Ready H: In operation On/Off L: display ON H: Display OFF RESET L: Normal H: Reset	
Write Display Data	H	L	Write Date									Writes data (DB0:7) into display data RAM . After writing instruction, Y address is increased by 1 automatically.
Read Display data	H	H	Read Date									Reads data (DB0:7) From display data RAM to the data bus.

12-1. Display On/Off

RS	R/W	DB7	DB6	DB5	DB4	DB3	DB2	DB1	DB0
0	0	0	0	1	1	1	1	1	D0

The display data appears when D is 1 and disappears when D is 0.

Though the data is not on the screen with D=0, it remains display data RAM.

Therefore, you can make it appear by changing D=0 into D=1.

12-2. Set Address (Y Address)

RS	R/W	DB7	DB6	DB5	DB4	DB3	DB2	DB1	DB0
0	0	0	1	AC5	AC4	AC3	AC2	AC1	AC0

Y address (AC0~AC5) of the display data RAM is set in the Y address counter.

An address is set by instruction and increased by 1 automatically by read or write operations of display data.

12-3. Set Page (X Address)

RS	R/W	DB7	DB6	DB5	DB4	DB3	DB2	DB1	DB0
0	0	1	0	1	1	1	AC2	AC1	AC0

X address (AC0~AC2) of the display data RAM is set in the X address register.

Writing or reading to or from MPU is executed in this specified page until the next page is set.

12-4. Display Start Line (Z Address)

RS	R/W	DB7	DB6	DB5	DB4	DB3	DB2	DB1	DB0
0	0	1	1	AC5	AC4	AC3	AC2	AC1	AC0

Z address (AC0~AC5) of the display data RAM is set in the display start line register and display at the top of the screen.

When the display duty cycle is 1/64 or others (1/32~1/64), the data of total line number of LCD screen, from the line specified by display start line instruction, is displayed.

12-5. Status Read

RS	R/W	DB7	DB6	DB5	DB4	DB3	DB2	DB1	DB0
0	0	BUSY	0	ON/OFF	RESET	0	0	0	0

■ **BUSY**

When BUSY is 1, the Chip is executing internal operation and no instructions are accepted.

When BUSY is 0, the Chip is ready to accept any instructions.

■ **ON/OFF**

When ON/OFF is 1, the display is on.

When ON/OFF is 0, the display is off.

■ **RESET**

When RESET is 1, the system is being initialized.

In this condition is 0, no instructions except status read can be accepted.

When RESET is 0, initialized has finished and the system is in the usual operation condition

12-6. Write Display data

R/W	DB7	DB6	DB5	DB4	DB3	DB2	DB1	DB0
1	D7	D6	D5	D4	D3	D2	D1	D0

Writes data (D0~D7) into the display data RAM.

After writing instruction, Y addressed is increased 1 automatically.

12-7. Read Display data

R/W	DB7	DB6	DB5	DB4	DB3	DB2	DB1	DB0
1	D7	D6	D5	D4	D3	D2	D1	D0

Reads data (D0~D7) from the display data RAM.

After reading instruction, Y addressed is increased 1 automatically.

13. LCD MODULES HANDLING PRECAUTIONS

- Please remove the protective foil of polarizer before using.
- The display panel is made of glass. Do not subject it to a mechanical shock by dropping it from a high place, etc.
- If the display panel is damaged and the liquid crystal substance inside it leaks out, do not get any in your mouth. If the substance comes into contact with your skin or clothes promptly wash it off using soap and water.
- Do not apply excessive force to the display surface or the adjoining areas since this may cause the color tone to vary.
- The polarizer covering the display surface of the LCD module is soft and easily scratched. Handle this polarizer carefully.
- To prevent destruction of the elements by static electricity, be careful to maintain an optimum work environment.
 - Be sure to ground the body when handling the LCD module.
 - Tools required for assembly, such as soldering irons, must be properly grounded.
 - To reduce the amount of static electricity generated, do not conduct assembly and other work under dry conditions.
 - The LCD module is coated with a film to protect the display surface. Exercise care when peeling off this protective film since static electricity may be generated.
- Storage precautions
When storing the LCD modules, avoid exposure to direct sunlight or to the light of fluorescent lamps. Keep the modules in bags designed to prevent static electricity charging under low temperature / normal humidity conditions (avoid high temperature / high humidity and low temperatures below 0°C. Whenever possible, the LCD modules should be stored in the same conditions in which they were shipped from our company.

14. OTHERS

- Liquid crystals solidify at low temperature (below the storage temperature range) leading to defective orientation of liquid crystal or the generation of air bubbles (black or white). Air bubbles may also be generated if the module is subjected to a strong shock at a low temperature.
- If the LCD modules have been operating for a long time showing the same display patterns may remain on the screen as ghost images and a slight contrast irregularity may also appear. Abnormal operating status can be resumed to be normal condition by suspending use for some time. It should be noted that this phenomena does not adversely affect performance reliability.
- To minimize the performance degradation of the LCD modules resulting from caused by static electricity, etc. exercise care to avoid holding the following sections when handling the modules:
 - Exposed area of the printed circuit board
 - Terminal electrode sections