

DISPLAY Elektronik GmbH

DATA SHEET

LCD MODULE

DEM 20485 FGH-PW

Product specification

Version : 1

18/Apr/2007

GENERAL SPECIFICATION

MODULE NO. :

DEM 20485 FGH-PW

CUSTOMER P/N

VERSION NO.	CHANGE DESCRIPTION	DATE
0	ORIGINAL VERSION	08/02/2007
1	MODIFY SECTION 6.1	18/04/2007

PREPARED BY: WJN

DATE: 18/04/2007

APPROVED BY: MH

DATE: 18/04/2007

CONTENTS

1. FUNCTIONS & FEATURES.....2

2. MECHANICAL SPECIFICATIONS2

3. EXTERNAL DIMENSIONS3

4. BLOCK DIAGRAM.....3

5. PIN ASSIGNMENT4

6. PCB DRAWING AND DESCRIPTION4

7. BACKLIGHT VOLTAGE AND CURRENT6

8. DISPLAY DATA RAM (DDRAM)6

9. MAXIMUM ABSOLUTE LIMIT (TA=25°C)7

10. ELECTRICAL CHARACTERISTICS7

11. CONTROL AND DISPLAY COMMAND.....9

12. STANDARD CHARACTER PATTERN10

13. LCM INITIALIZING BY INSTRUCTION.....11

14. LCD MODULES HANDLING PRECAUTIONS.....13

15. OTHERS13

1. FUNCTIONS & FEATURES

MODULE	LCD TYPE	Remark
DEM 20485 FGH-PW	FSTN Transflecive Positive Mode	RoHS Conformed

- Viewing Direction : 6 o'clock
- Driving Scheme : 1/16 Duty Cycle, 1/5 Bias
- Power Supply Voltage : 5.0 Volt (typ.)
- Backlight Color : LED, White, Lightguide
- VLCD Adjustable For Best Contrast : 4.5 Volt (typ.)
- Display Format : 20 x 4 Characters (5x8 dots, Format: 208 Kinds)
- Internal Memory : CGROM (10,080 bits)
: CGRAM (64 x 8 bits)
: DDRAM (80 x 8 bits for Digits)
- Interface : Easy Interface with a 4-bit or 8-bit MPU

2. MECHANICAL SPECIFICATIONS

- Module Size : 98.00 x 60.00 x 14.1 mm
- Character Pitch : 3.55 x 5.35 mm
- Character Size : 2.95 x 4.75 mm
- Character Font : 5 x 8 dots
- Dot Size : 0.55 x 0.55 mm
- Dot Pitch : 0.60 x 0.60 mm
- Dot Size : 0.05 mm

3. EXTERNAL DIMENSIONS

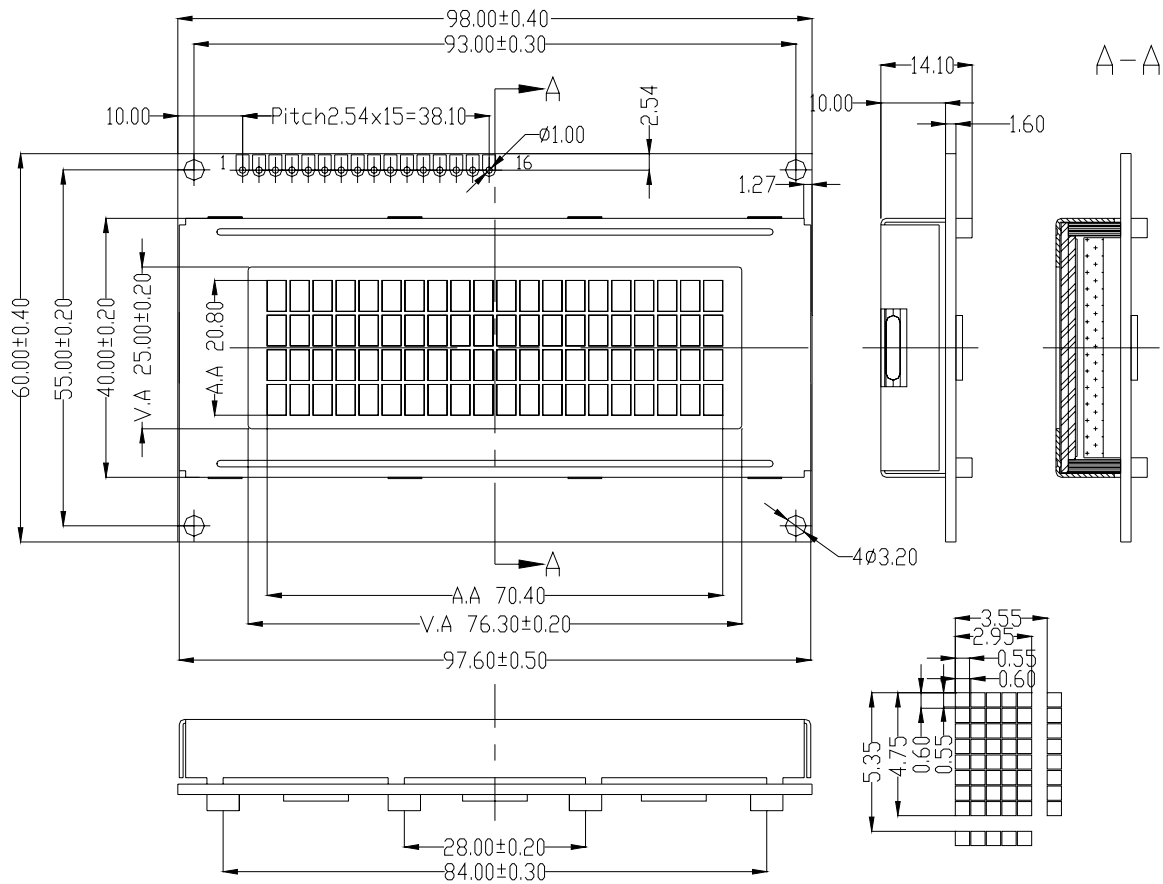

4. BLOCK DIAGRAM

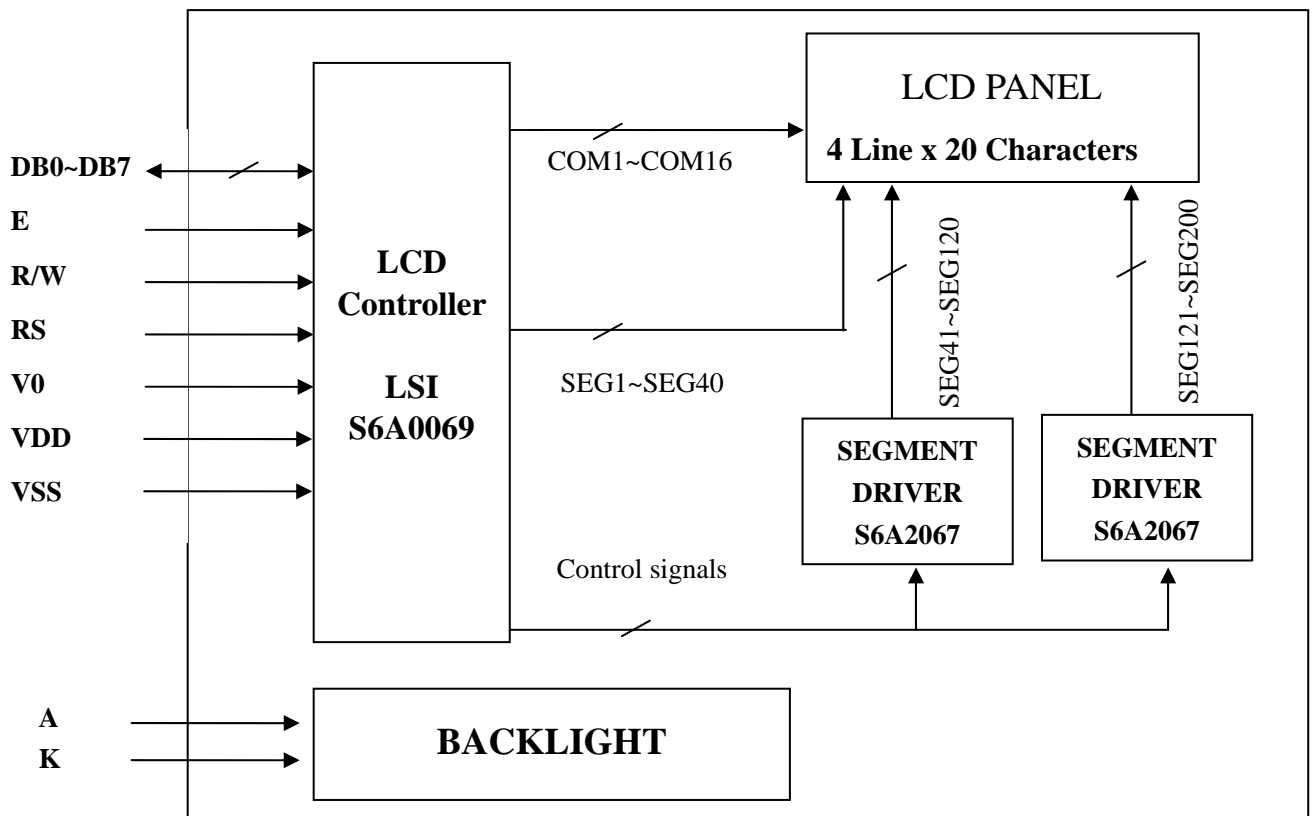

5. PIN ASSIGNMENT

Pin No.	Symbol	Function
1	VSS	Ground terminal of module
2	VDD	Power supply of module +5V
3	V0	Power Supply for LCD
4	RS	Register Select RS=0 (Instruction Register) RS=1 (Data Register)
5	R/W	Read or Write R/W=1 (Read) R/W=0 (Write)
6	E	Enable signal
7	DB0	Bi-directional Data Bus, Data Transfer is performed Once, thru DB0~DB7, in the case of interface data. Length is 8-bits; and twice, thru DB4~DB7 in the case of interface data length is 4-bits. Upper four bits first then lower four bits.
8	DB1	
9	DB2	
10	DB3	
11	DB4	
12	DB5	
13	DB6	
14	DB7	
15	LED-(K)	Place also refer to 6.1 PCB Drawing and description
16	LED-(A)	Place also refer to 6.1 PCB Drawing and description

6. PCB DRAWING AND DESCRIPTION

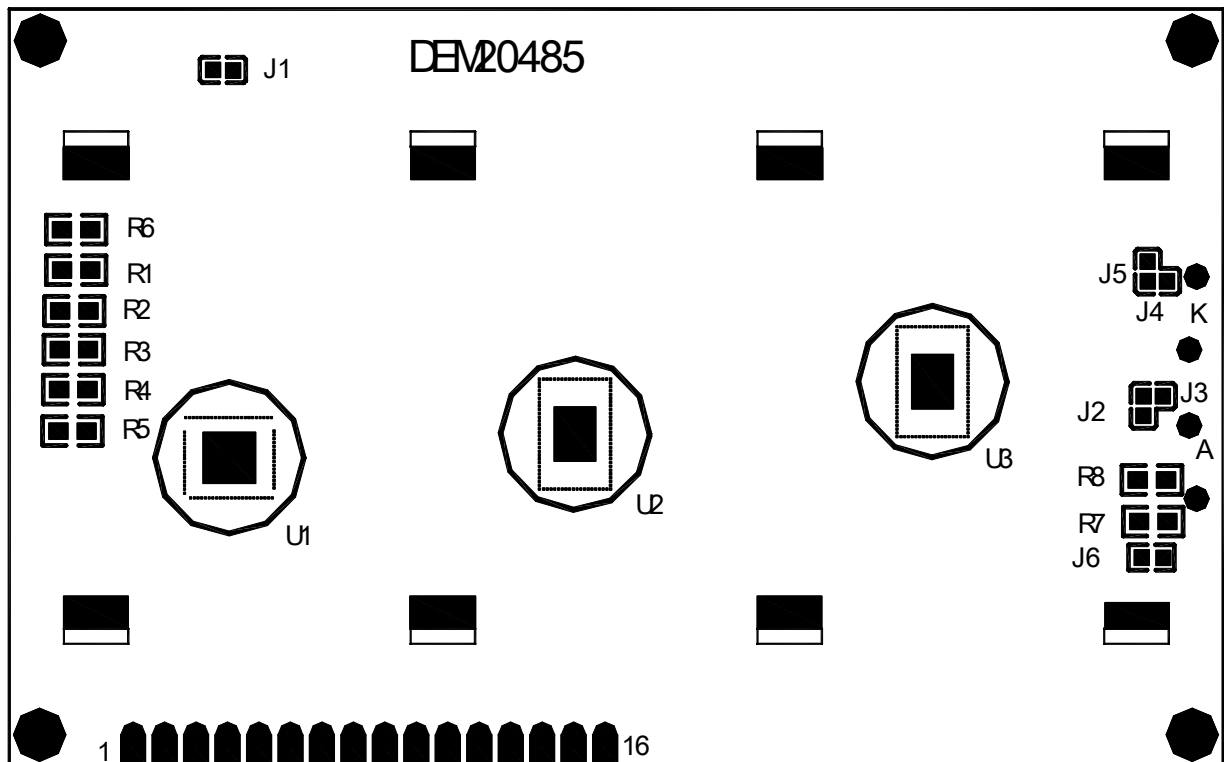

6.1 DESCRIPTION:

6-1-1.The polarity of the pin 15 and the pin 16

LED Polarity(1)	
15 Pin	16Pin
Anode	Cathode
J3=J5=open J2=J4=closed	

LED Polarity(2)	
15 Pin	16 Pin
Cathode	Anode
J3=J5= closed J2=J4= open	

Note: In application module, J2=J4= open and J3=J5=0 Ohm

6-1-2. The metal-bezel is set be on ground when the J1 is closed

Note: In application module, J1=0 Ohm

6-1-3. The LED resistor on board are used when J6 is open

Note: In application module, J6=open

6-1-4.The R7 and the R8 are the LED resistor.

Note: In application module, R7=12 Ohm, R8=open

6.2 Example application

6-2-1. The LED resistor should be bridged as following. Then customer needs to use internal resistors

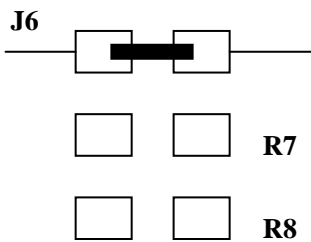

6-2-2.The 15 pin is the cathode and the 16 pin is the anode as following

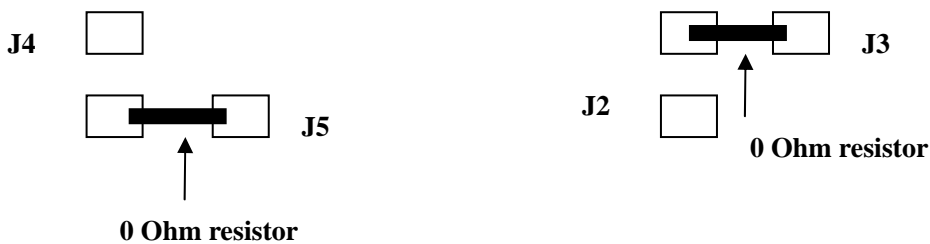

6-2-3.The metal-bezel is on ground as following.

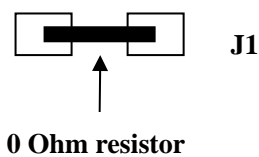

7. BACKLIGHT VOLTAGE AND CURRENT

Item	Symbol	MIN.	TYP.	MAX.	Unit	Conditions
Forward Voltage	Vf		4.0	-	V	
Forward Current	If		60	80	mA	If=4.0V
Power Dissipation	Pd		0.28		W	If=4.0V
Reverse Voltage	VR		4.0		V	
Reverse Current	IR		0.8		mA	
Luminous Intensity	L	65	88		cd/m ²	If=4.0V
Luminous Uniformity	Δ L	70			%	
Chromaticity coordinate		X=0.27 Y=0.275		X=0.3 Y=0.315		
Emission Wavelength	λ p		White		nm	If=20mA, Ta=25°C
Spectral Range			20			Each chip

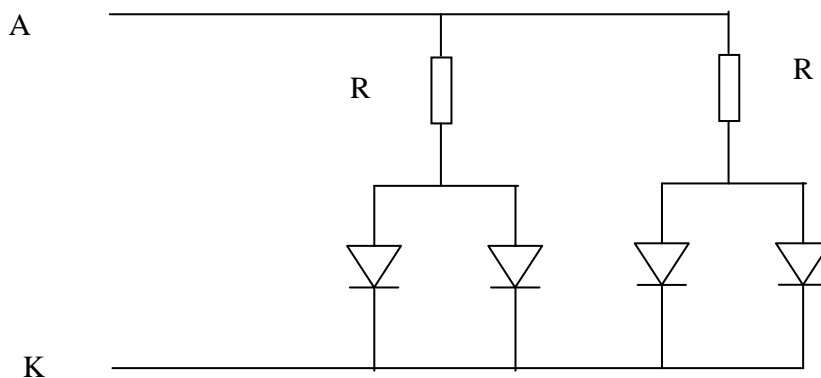

8. DISPLAY DATA RAM (DDRAM)

	1	2	3	4	5	6	7	8	9	10	11	12	13	14	15	16	17	18	19	20
FIRST LINE	00	01	02	03	04	05	06	07	08	09	0A	0B	0C	0D	0E	0F	10	11	12	13
SECOND LINE	40	41	42	43	44	45	46	47	48	49	4A	4B	4C	4D	4E	4F	50	51	52	53
THIRD LINE	14	15	16	17	18	19	1A	1B	1C	1D	1E	1F	20	21	22	23	24	25	26	27
FOURTH LINE	54	55	56	57	58	59	5A	5B	5C	5D	5E	5F	60	61	62	63	64	65	66	67

DISPLAY POSITION ←

←

DDRAM ADDRESS ←

9. MAXIMUM ABSOLUTE LIMIT (Ta=25°C)

Item	Symbol	Standard value	Unit
Power supply voltage (1)	V _{DD}	-0.3 ~ +7.0	V
Power supply voltage (2)	V ₀	V _{DD} -13.5 ~ V _{DD} +0.3	V
Input voltage	V _{IN}	-0.3 ~ V _{DD} +0.3	V
Operating temperature	Topr	-20 ~ +70	°C
Storage temperature	Tstg	-20 ~ +75	°C

*Voltage greater than above may damage to the Circuit.

$$V_{DD} > V_1 > V_2 > V_3 > V_4 > V_5$$

10. ELECTRICAL CHARACTERISTICS

10-1 DC Characteristics (V_{DD} = 4.5Volt ~ 5.5Volt)

Item	Symbol	Standard Value			Test Condition	Unit
		MIN	TYP	MAX		
Operating Voltage	V _{DD}	4.5	5	5.5	-----	V
Supply Current	I _{DD}	----	0.35	0.6	V _{DD} =5V, fosc=270kHz	mA
LCD Driving Voltage	V _{LCD}	3.0	---	13.0	V _{DD} -V5 (1/5,1/4 Bias)	V

10-2 AC Characteristics (V_{DD} = 4.5Volt ~ 5.5Volt)

10-2-1 Write mode

Characteristic	Symbol	Min	Type	Max	Unit	Test PIN
E Cycle Time	t _C	500	---	---	ns	E
E Rise Time	t _R	---	---	20	ns	E
E Fall Time	t _F	---	---	20	ns	E
E Pulse width (High, Low)	t _w	230	---	---	ns	E
R/W and RS Set-up Time	t _{SU1}	40	---	---	ns	R/W,RS
R/W and RS Hold Time	t _{H1}	10	---	---	ns	R/W,RS
Data Set-up Time	t _{SU2}	80	---	---	ns	DB0~DB7
Data Hold Time	t _{H2}	10	---	---	ns	DB0~DB7

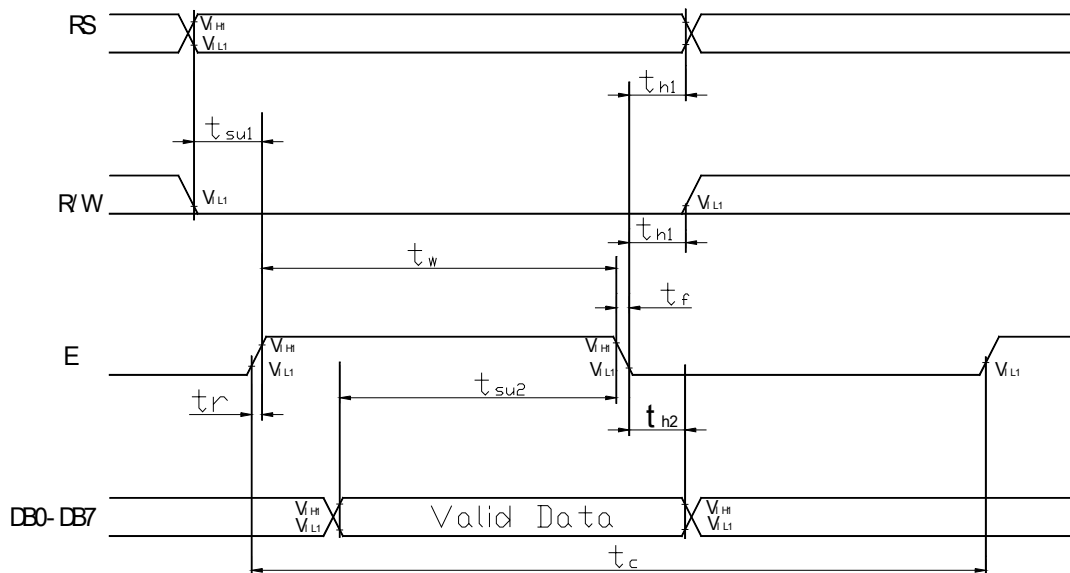

10-2-2 Read mode

Characteristic	Symbol	Min	Type	Max	Unit	Test PIN
E Cycle Time	t_C	500	---	---	ns	E
E Rise Time	t_R	---	---	20	ns	E
E Fall Time	t_F	---	---	20	ns	E
E Pulse width (High, Low)	t_W	230	---	---	ns	E
R/W and RS Set-up Time	t_{SU}	40	---	---	ns	R/W,RS
R/W and RS Hold Time	t_H	10	---	---	ns	R/W,RS
Data Output Delay Time	t_D	---	---	120	ns	DB0~DB7
Data Hold Time	t_{DH}	5	---	---	ns	DB0~DB7

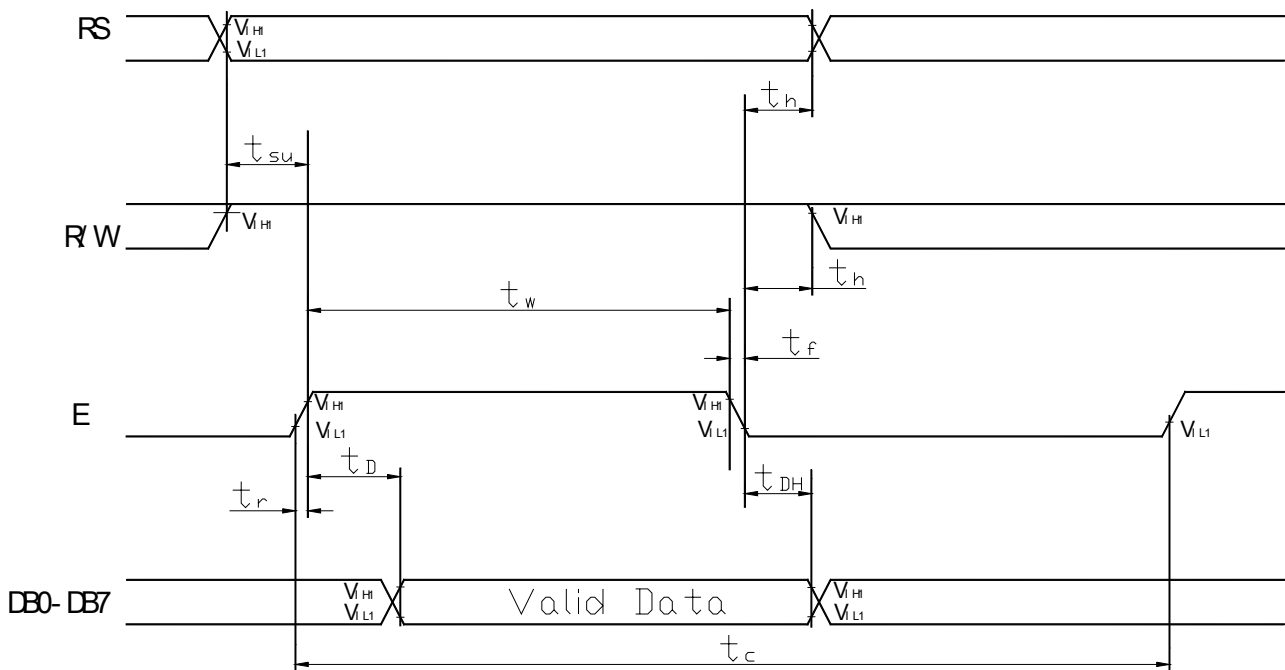

11. CONTROL AND DISPLAY COMMAND

Command	RS	R/W	DB7	DB6	DB5	DB4	DB3	DB2	DB1	DB0	Execution time (fosc=270KHz)	Remark																		
clear Display	L	L	L	L	L	L	L	L	L	H	1.53ms	Write "20H" to DDRAM and set DDRAM address to "00H" from AC																		
Return home	L	L	L	L	L	L	L	L	L	H	1.53ms	Cursor move to first digit																		
Entry mode set	L	L	L	L	L	L	L	L	H	I/D	SH	39us I/D: set cursor move direction <table border="1"> <tr> <td>I/D</td> <td>H</td> <td>Increase</td> </tr> <tr> <td>I/D</td> <td>L</td> <td>Decrease</td> </tr> </table> SH: Specifies shift of display <table border="1"> <tr> <td>SH</td> <td>H</td> <td>Display is shifted</td> </tr> <tr> <td>SH</td> <td>L</td> <td>Display is not shifted</td> </tr> </table>	I/D	H	Increase	I/D	L	Decrease	SH	H	Display is shifted	SH	L	Display is not shifted						
I/D	H	Increase																												
I/D	L	Decrease																												
SH	H	Display is shifted																												
SH	L	Display is not shifted																												
Display on/off control	L	L	L	L	L	L	H	D	C	B	39us	Display <table border="1"> <tr> <td>D</td> <td>H</td> <td>Display on</td> </tr> <tr> <td>D</td> <td>L</td> <td>Display off</td> </tr> </table> Cursor <table border="1"> <tr> <td>C</td> <td>H</td> <td>Cursor on</td> </tr> <tr> <td>C</td> <td>L</td> <td>Cursor off</td> </tr> </table> Blinking <table border="1"> <tr> <td>B</td> <td>H</td> <td>Blinking on</td> </tr> <tr> <td>B</td> <td>L</td> <td>Blinking off</td> </tr> </table>	D	H	Display on	D	L	Display off	C	H	Cursor on	C	L	Cursor off	B	H	Blinking on	B	L	Blinking off
D	H	Display on																												
D	L	Display off																												
C	H	Cursor on																												
C	L	Cursor off																												
B	H	Blinking on																												
B	L	Blinking off																												
Cursor or Display Shift	L	L	L	L	L	H	S/C	R/L	---	---	39us	<table border="1"> <tr> <td>SC</td> <td>H</td> <td>Display shift</td> </tr> <tr> <td>SC</td> <td>L</td> <td>Cursor move</td> </tr> <tr> <td>R/L</td> <td>H</td> <td>Right shift</td> </tr> <tr> <td>R/L</td> <td>L</td> <td>Left shift</td> </tr> </table>	SC	H	Display shift	SC	L	Cursor move	R/L	H	Right shift	R/L	L	Left shift						
SC	H	Display shift																												
SC	L	Cursor move																												
R/L	H	Right shift																												
R/L	L	Left shift																												
function Set	L	L	L	L	H	DL	N	F	---	---	39us	<table border="1"> <tr> <td>DL</td> <td>H</td> <td>8bits interface</td> </tr> <tr> <td>DL</td> <td>L</td> <td>4bits interface</td> </tr> <tr> <td>N</td> <td>H</td> <td>2 line display</td> </tr> <tr> <td>N</td> <td>L</td> <td>1 line display</td> </tr> <tr> <td>F</td> <td>H</td> <td>5 x 11 dots</td> </tr> <tr> <td>F</td> <td>L</td> <td>5 x 8 dots</td> </tr> </table>	DL	H	8bits interface	DL	L	4bits interface	N	H	2 line display	N	L	1 line display	F	H	5 x 11 dots	F	L	5 x 8 dots
DL	H	8bits interface																												
DL	L	4bits interface																												
N	H	2 line display																												
N	L	1 line display																												
F	H	5 x 11 dots																												
F	L	5 x 8 dots																												
Set CGRAM address	L	L	L	H	AC5	AC4	AC3	AC2	AC1	AC0	39us	CGRAM data is sent and received after this setting																		
Set DDRAM address	L	L	H	AC6	AC5	AC4	AC3	AC2	AC1	AC0	39us	DDRAM data is sent and received after this setting																		
Read busy flag& address	L	H	BF	AC6	AC5	AC4	AC3	AC2	AC1	AC0	0us	<table border="1"> <tr> <td>BF</td> <td>H</td> <td>Busy</td> </tr> <tr> <td>BF</td> <td>L</td> <td>Ready</td> </tr> </table> -Reads BF indication internal operating is being performed -Reads address counter contents	BF	H	Busy	BF	L	Ready												
BF	H	Busy																												
BF	L	Ready																												
Write data to RAM	H	L	D7	D6	D5	D4	D3	D2	D1	D0	43us	Write data into DDRAM or CGRAM																		
Read data from RAM	H	H	D7	D6	D5	D4	D3	D2	D1	D0	43us	Read data from DDRAM or CGRAM																		

12. STANDARD CHARACTER PATTERN

Upper(4bit) Lower(4bit)	LLLL	LLLH	LLHL	LLHH	LHLL	LHLH	LHHL	LHHH	HLLL	HLLH	HLHL	HLHH	HHLL	HHLH	HHHL	HHHH
LLLL CG RAM (1)																
LLLH (2)																
LLHL (3)																
LLHH (4)																
LHLL (5)																
LHLH (6)																
LHHL (7)																
LHHH (8)																
HLLL (1)																
HLLH (2)																
HLHL (3)																
HLHH (4)																
HHLL (5)																
HHLH (6)																
HHHL (7)																
HHHH (8)																

13. LCM INITIALIZING BY INSTRUCTION

13-1 8-bit interface mode

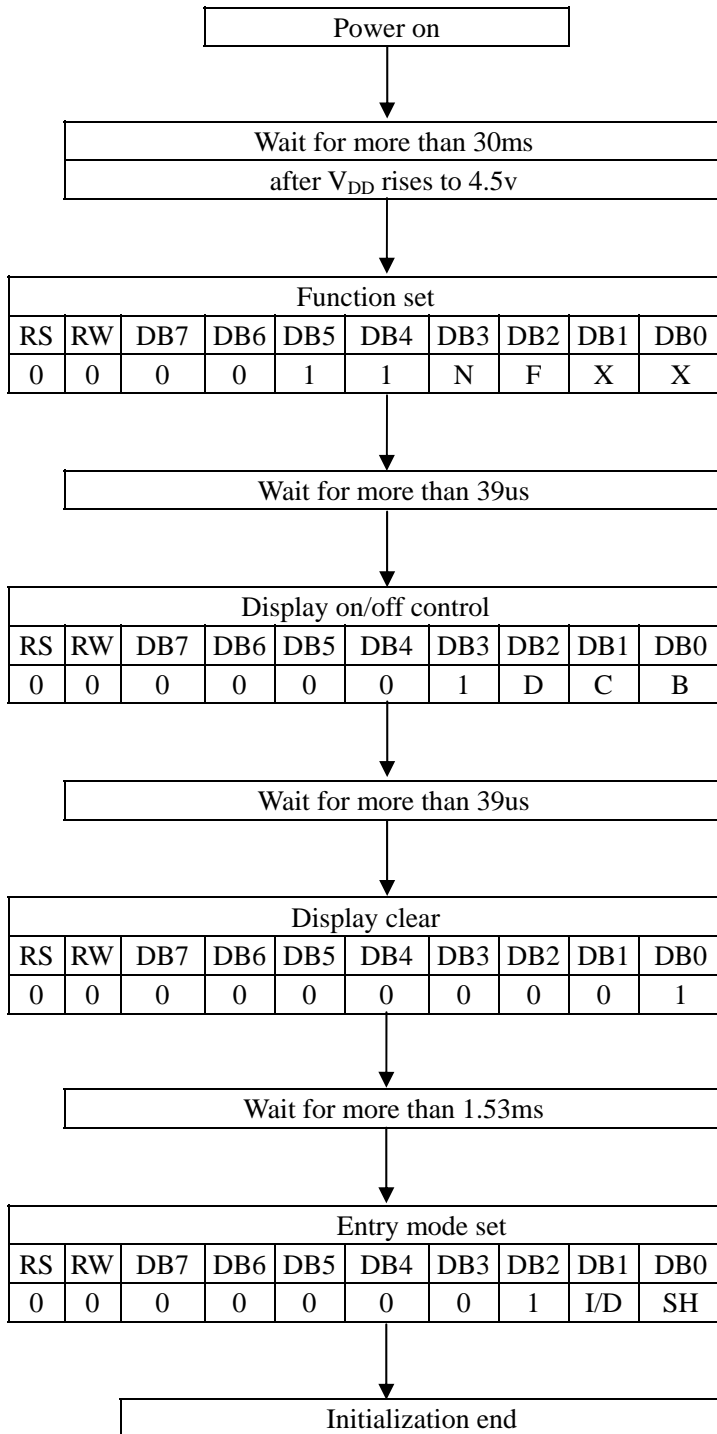

Condition : fosc=270khz

N	0	1-line mode
	1	2-line mode

F	0	5 x 8 dots
	1	5 x 11 dots

D	0	display off
	1	display on

C	0	cursor off
	1	cursor on

B	0	blink off
	1	blink on

I/D	0	decrement mode
	1	increment mode

SH	0	entire shift off
	1	entire shift on

13-2 4-bit interface mode

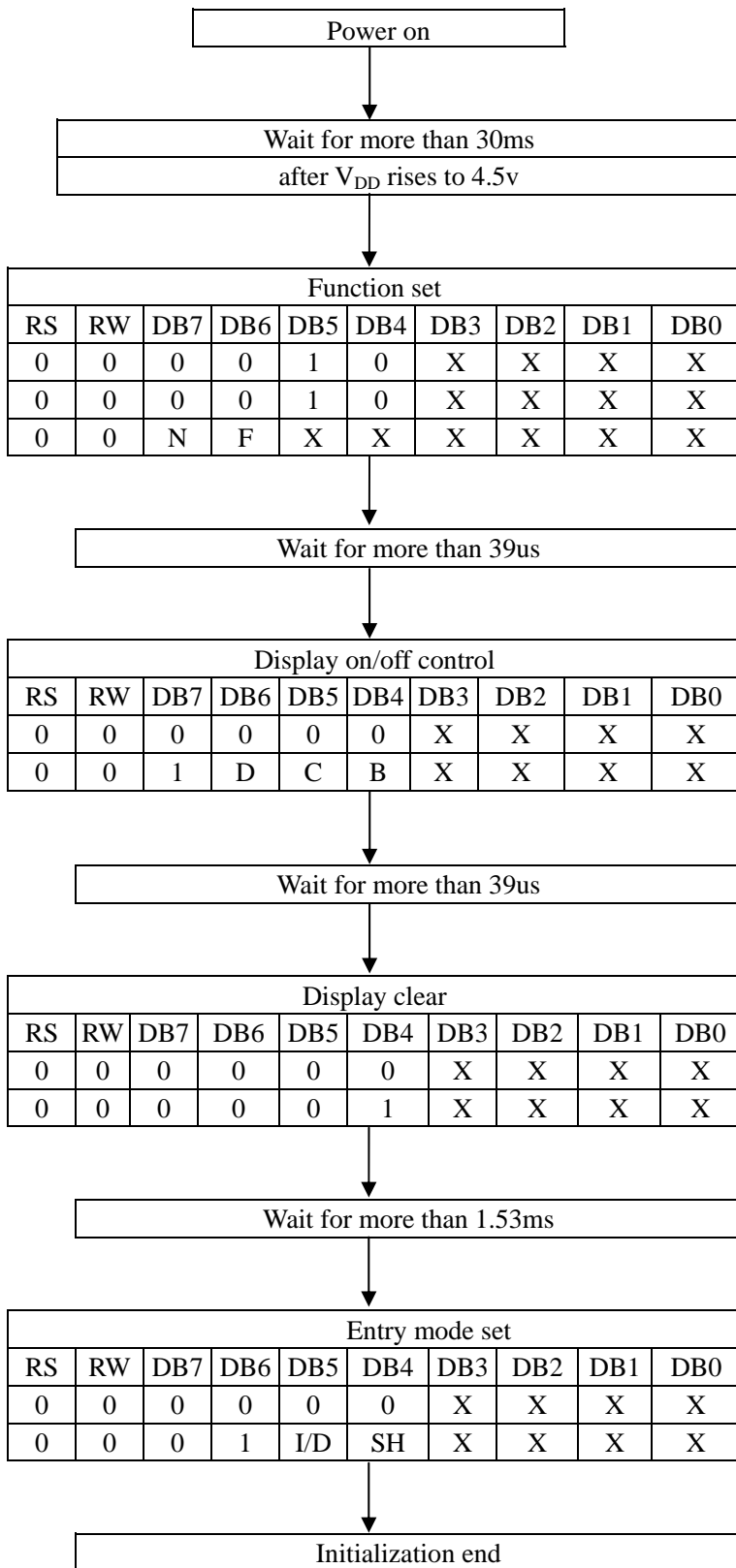

Condition : fosc=270khz

N	0	1-line mode
	1	2-line mode
F	0	5 x 8 dots
	1	5 x 11 dots

D	0	display off
	1	Display on
C	0	cursor off
	1	cursor on
B	0	blink off
	1	blink on

I/D	0	decrement mode
	1	increment mode
SH	0	entire shift off
	1	entire shift on

14. LCD MODULES HANDLING PRECAUTIONS

- Please remove the protection foil of polarizer before using.
- The display panel is made of glass. Do not subject it to a mechanical shock by dropping it from a high place, etc.
- If the display panel is damaged and the liquid crystal substance inside it leaks out, do not get any in your mouth. If the substance come into contact with your skin or clothes promptly wash it off using soap and water.
- Do not apply excessive force to the display surface or the adjoining areas since this may cause the color tone to vary.
- The polarizer covering the display surface of the LCD module is soft and easily scratched. Handle this polarize carefully.
- To prevent destruction of the elements by static electricity, be careful to maintain an optimum work environment.
 - Be sure to ground the body when handling the LCD module.
 - Tools required for assembly, such as soldering irons, must be properly grounded.
 - To reduce the amount of static electricity generated, do not conduct assembly and other work under dry conditions.
 - The LCD module is coated with a film to protect the display surface. Exercise care when peeling off this protective film since static electricity may be generated.
- Storage precautions
When storing the LCD modules, avoid exposure to direct sunlight or to the light of fluorescent lamps. Keep the modules in bags designed to prevent static electricity charging under low temperature / normal humidity conditions (avoid high temperature / high humidity and low temperatures below 0°C). Whenever possible, the LCD modules should be stored in the same conditions in which they were shipped from our company.

15. OTHERS

- Liquid crystals solidify at low temperature (below the storage temperature range) leading to defective orientation of liquid crystal or the generation of air bubbles (black or white). Air bubbles may also be generated if the module is subjected to a strong shock at a low temperature.
- If the LCD modules have been operating for a long time showing the same display patterns may remain on the screen as ghost images and a slight contrast irregularity may also appear. Abnormal operating status can be resumed to be normal condition by suspending use for some time. It should be noted that this phenomena does not adversely affect performance reliability.
- To minimize the performance degradation of the LCD modules resulting from caused by static electricity, etc. exercise care to avoid holding the following sections when handling the modules:
 - Exposed area of the printed circuit board
 - Terminal electrode sections