

PRELIMINARY SPEC

Part Number: BLS101SYC-28V-P

Super Bright Yellow

Features

- BUILT-IN CURRENT LIMITING RESISTOR FOR DIRECT APPLICATION OF DIFFERENT ACROSS CURRENT.
- LONG LIFE.
- LOW CURRENT, POWER SAVINGS.
- LOW MAINTENANCE.
- DIFFERENT COLOR AVAILABLE.
- SOLID STATE, HIGH VIBRATION RESISTANT.
- 28V INTERNAL RESISTOR.
- RoHS COMPLIANT.

Description

The Super Bright Yellow device is made with InGaAlP (on GaAs substrate) light emitting diode chip.

Package Dimensions

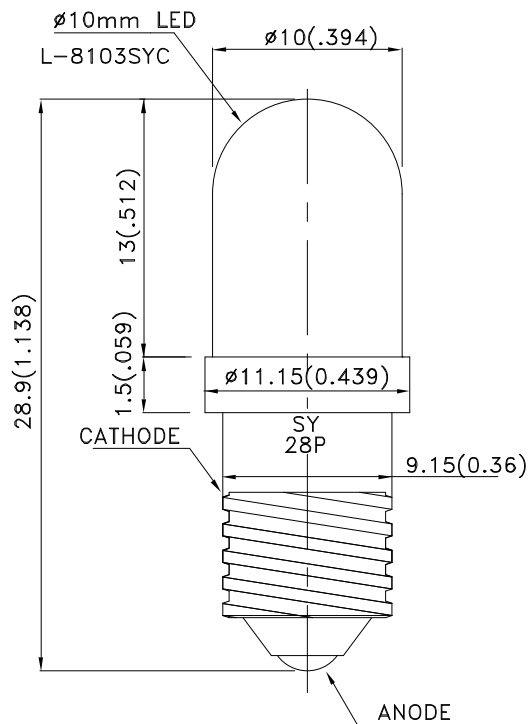

Notes:

1. All dimensions are in millimeters (inches).
2. Tolerance is $\pm 0.25(0.01)$ unless otherwise noted.
3. Specifications are subject to change without notice.



Selection Guide

Part No.	Dice	Lens Type	Iv (mcd) V= 28V		Viewing Angle
			Min.	Typ.	2θ1/2
BLS101SYC-28V-P	Super Bright Yellow (InGaAlP)	WATER CLEAR	650	1800	20°

Note:

1. θ1/2 is the angle from optical centerline where the luminous intensity is 1/2 the optical centerline value.

Electrical / Optical Characteristics at TA=25°C

Symbol	Parameter	Device	Typ.	Max.	Units	Test Conditions
λ_{peak}	Peak Wavelength	Super Bright Yellow	590		nm	V _F =28V
λ_D	Dominant Wavelength	Super Bright Yellow	588		nm	V _F =28V
$\Delta\lambda_{1/2}$	Spectral Line Half-width	Super Bright Yellow	28		nm	V _F =28V
I _F	Forward Current	Super Bright Yellow	13	16	mA	V _F =28V
I _R	Reverse Current	Super Bright Yellow		10	uA	V _R = 5V

Absolute Maximum Ratings at TA=25°C

Parameter	Super Bright Yellow	Units
Power dissipation	480	mW
Forward Voltage	30	V
Reverse Voltage	5	V
Operating Temperature	-40°C To +70°C	
Storage Temperature	-40°C To +85°C	

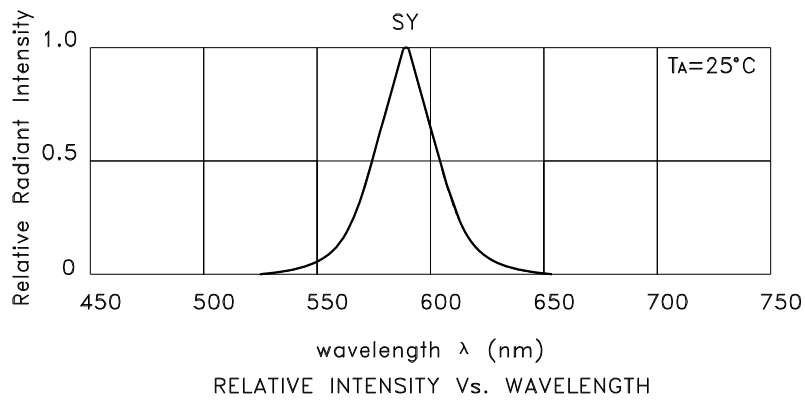

Super Bright Yellow BLS101SYC-28V-P

