

PRELIMINARY SPEC

Part Number : KA-1011PB9AZC

Blue



ATTENTION
OBSERVE PRECAUTIONS
FOR HANDLING
ELECTROSTATIC
DISCHARGE
SENSITIVE
DEVICES

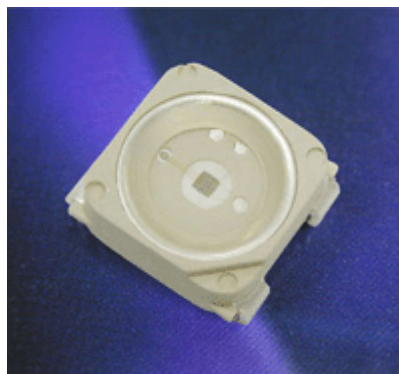

Features

- PLCC-4 PACKAGE.
- SINGLE COLOR.
- HIGH LUMINANCE.
- HIGH POWER, OPERATING CURRENT @350mA.
- SUITABLE FOR ALL SMT ASSEMBLY METHODS.
- PACKAGE : 500PCS / REEL.
- MOISTURE SENSITIVITY LEVEL : LEVEL 6.
- PATENT PENDING
- RoHS COMPLIANT.

Description

The LED is encapsulated with a soft silicone material.

Package Dimensions

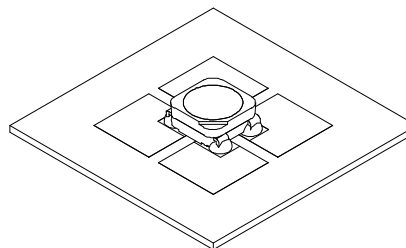
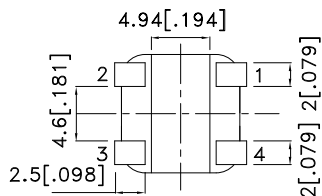
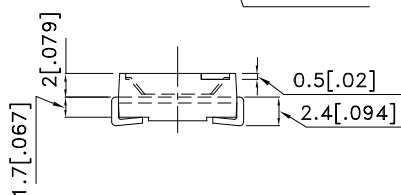
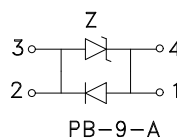
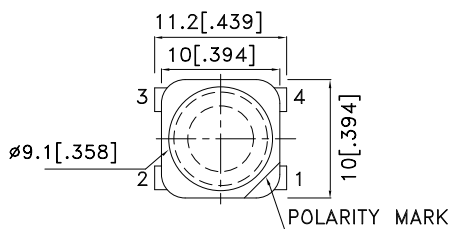

Notes:

1. All dimensions are in millimeters (inches).
2. Tolerance is $\pm 0.25(0.01)$ unless otherwise noted.
3. Specifications are subject to change without notice.
4. The device has a single mounting surface. The device must be mounted according to the specifications.



Kingbright

Applications

- traffic signaling.
- backlighting (illuminated advertising , general lighting).
- interior and exterior automotive lighting.
- substitution of micro incandescent lamps.
- portable light source (e.g. bicycle flashlight).
- signal and symbol luminaire for orientation.
- marker lights (e.g. steps, exit ways, etc).
- decorative and entertainment lighting.
- indoor and outdoor commercial and residential architectural lighting.

Application Notes

- Pressure or stress can damage the encapsulating material and affect the reliability of the LED. Precaution should be taken to avoid pressure on the LED encapsulating surface.
- Static electricity and surge damage the LEDs.
 - It is recommended to use a wrist band or anti-electrostatic glove when handling the LEDs.
 - All devices, equipment and machinery must be electrically grounded.
- Handling Indications
 - Use proper handling techniques to prevent damage to the LED surface. Minimize mechanical stress on the LED surface during processing and handling. Do not touch the emitting surface with sharp objects to avoid scratching or damaging the LED.



Figure 1

In general, LEDs should be handled by the sides of the package. Handling instruments should not touch the emitting surface of the LED package.



Figure 2

For automated pick-and-place machines, the pickup nozzle should be larger than the size of the LED reflector area to avoid placing excess pressure on the LED surface.

Selection Guide

Part No.	Dice	Lens Type	luminous Intensity Iv(cd)@ 350 mA [2]		Φv (lm) @ 350 mA [2]		Viewing Angle [1]
			Min.	Typ.	Min.	Typ.	2θ1/2
KA-1011PB9AZC	BLUE (InGaN)	WATER CLEAR	1.5	2.8	4.3	8	45°

Notes:

1. θ1/2 is the angle from optical centerline where the luminous intensity is 1/2 the optical centerline value.
2. Luminous intensity / luminous flux: +/-15%.

Absolute Maximum Ratings at TA=25°C

Parameter	Symbol	Value	Unit
Power Dissipation	Pt	1.2	W
Junction Temperature	TJ	110	°C
Operating Temperature	Top	-40 To +85	°C
Storage Temperature	Tstg	-40 To +85	°C
DC Forward Current [1]	IF	350	mA
Peak Forward Current [3]	IFM	500	mA
Thermal Resistance [1]	Rth	60	°C/W

Notes:

1. Results from mounting on PC board FR4 (pad size $\geq 100\text{mm}^2$), mounted on pc board-metal core PCB is recommend for lowest thermal resistance.
2. 0.1ms Pulse Width, 1/10 Duty Cycle..

Electrical / Optical Characteristics at TA=25°C

Parameter	Symbol	Value	Unit
Wavelength at peak emission IF=350mA [Typ.]	λ_{peak}	463	nm
Dominant Wavelength IF=350mA [Typ.]	λ_{Dom} [1]	470	nm
Spectral bandwidth at 50%ΦREL MAX IF=350mA [Typ.]	$\Delta\lambda$	22	nm
Forward Voltage IF=350mA [Min.]	VF [2]	3.0	V
Forward Voltage IF=350mA [Typ.]		3.4	
Forward Voltage IF=350mA [Max.]		3.9	
Temperature coefficient of λ_{peak} IF=350mA, $-10^\circ\text{C} \leq T \leq 100^\circ\text{C}$ [Typ.]	TC λ_{peak}	0.04	nm/°C
Temperature coefficient of λ_{dom} IF=350mA, $-10^\circ\text{C} \leq T \leq 100^\circ\text{C}$ [Typ.]	TC λ_{dom}	0.03	nm/°C
Temperature coefficient of VF IF=350mA, $-10^\circ\text{C} \leq T \leq 100^\circ\text{C}$ [Typ.]	TCV	-2.2	mV/°C

Notes:

- 1.Wavelength: +/-1nm.
- 2.Forward Voltage: +/-0.1V.

KA-1011PB9AZC

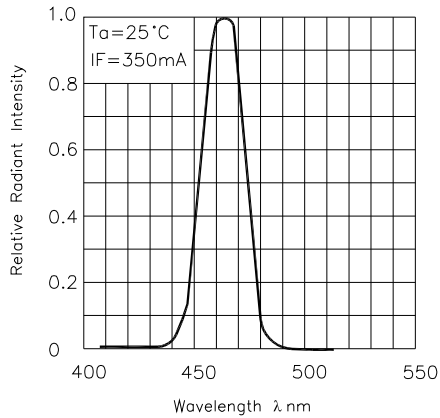

RELATIVE INTENSITY Vs. WAVELENGTH

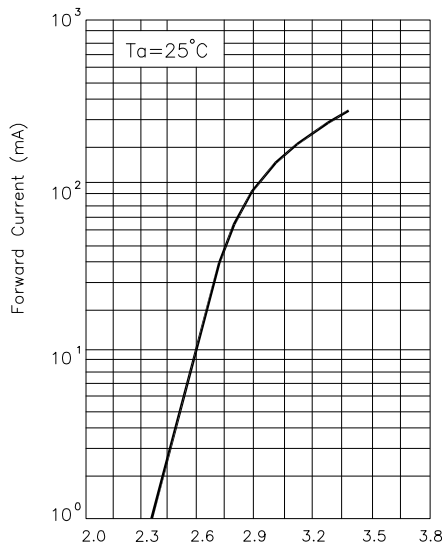
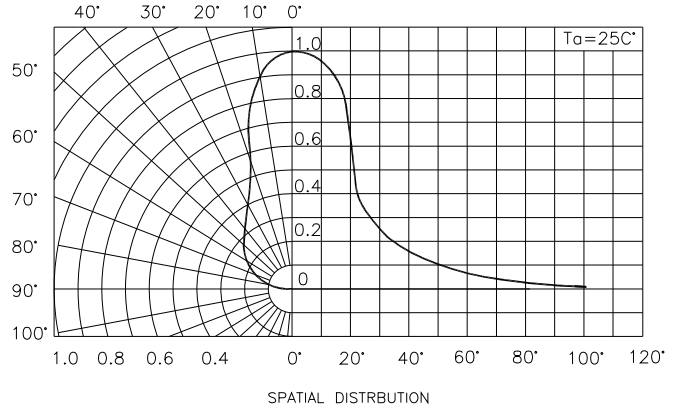

FORWARD CURRENT Vs. FORWARD VOLTAGE

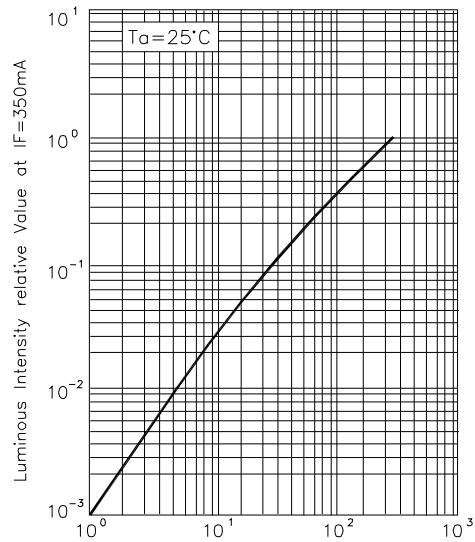

LUMINOUS INTENSITY Vs. FORWARD CURRENT

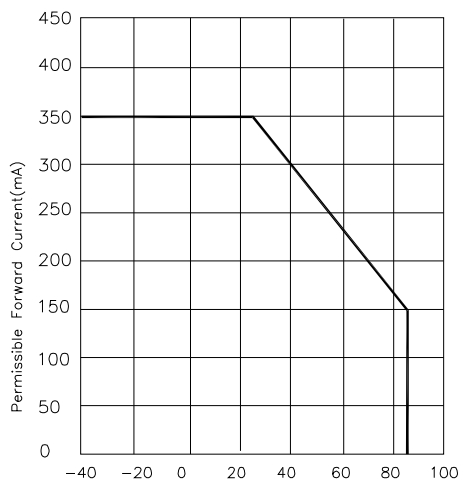

FORWARD CURRENT DERATING CURVE

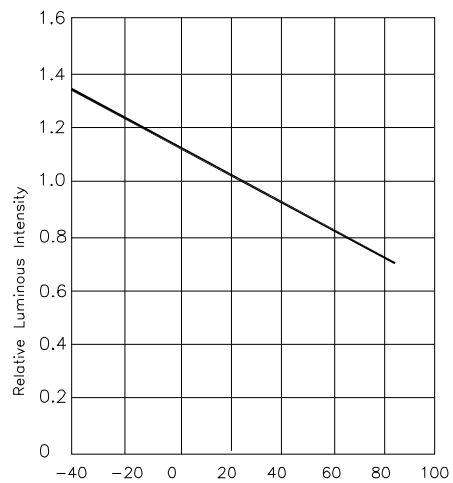

LUMINOUS INTENSITY Vs. AMBIENT TEMPERATURE

KA-1011PB9AZC

Reflow Soldering Profile For Lead-free SMT Process.

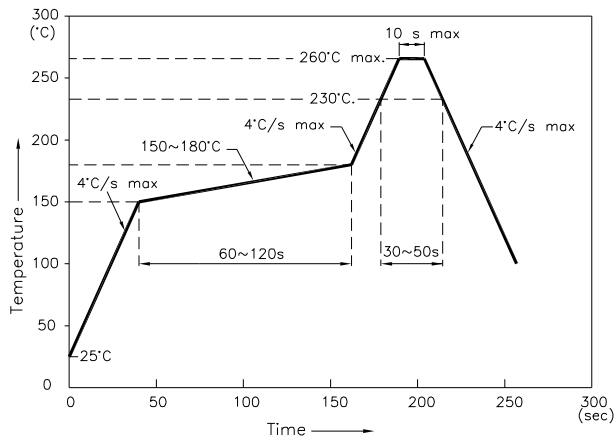

NOTES:

1. We recommend the reflow temperature 245°C(+/-5°C). The maximum soldering temperature should be limited to 260°C.
2. Don't cause stress to the epoxy resin while it is exposed to high temperature.
3. Number of reflow process shall be 2 times or less.

Recommended Soldering Pattern (Units : mm; Tolerance: ±0.1)

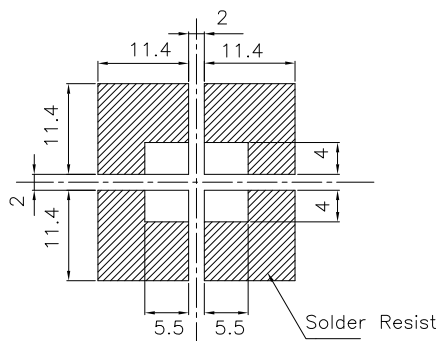

Reel Dimension

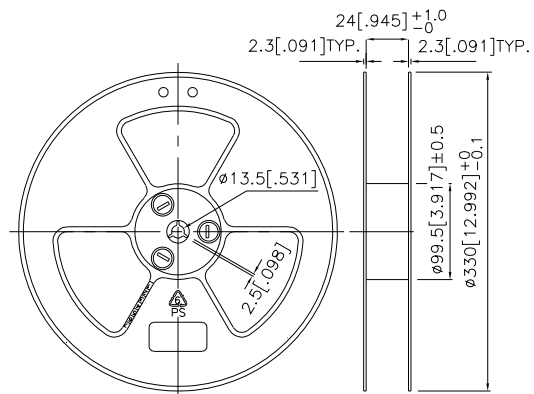

Tape Specifications (Units : mm)

