

DS10CP154

1.5 Gbps LVDS Crosspoint Switch

General Description

The DS10CP154 is a 1.5 Gbps 4x4 LVDS crosspoint switch optimized for high-speed signal routing and switching over FR-4 printed circuit board backplanes and balanced cables. Fully differential signal paths ensure exceptional signal integrity and noise immunity. The non-blocking architecture allows connections of any input to any output or outputs. The switch configuration can be accomplished via external pins or the System Management Bus (SMBus) interface. In addition, the SMBus circuitry enables the loss of signal (LOS) monitors that can inform a system of the presence of an open inputs condition (e.g. disconnected cable).

Wide input common mode range allows the switch to accept signals with LVDS, CML and LVPECL levels; the output levels are LVDS. A very small package footprint requires a minimal space on the board while the flow-through pinout allows easy board layout. Each differential input and output is internally terminated with a 100Ω resistor to lower device insertion and return losses, reduce component count and further minimize board space.

Features

- DC - 1.5 Gbps low jitter, low skew, low power operation
- Pin and SMBus configurable, fully differential, non-blocking architecture
- Wide input common mode range enables DC coupled interface to CML or LVPECL drivers
- LOS circuitry detects open inputs fault condition
- On-chip 100 Ω input and output termination minimizes insertion and return losses, reduces component count and minimizes board space
- 8 kV ESD on LVDS I/O pins protects adjoining components
- Small 6 mm x 6 mm 40-LLP space saving package

Applications

- High-speed channel select applications
- Clock and data buffering and muxing
- SD / HD SDI Routers

Typical Application

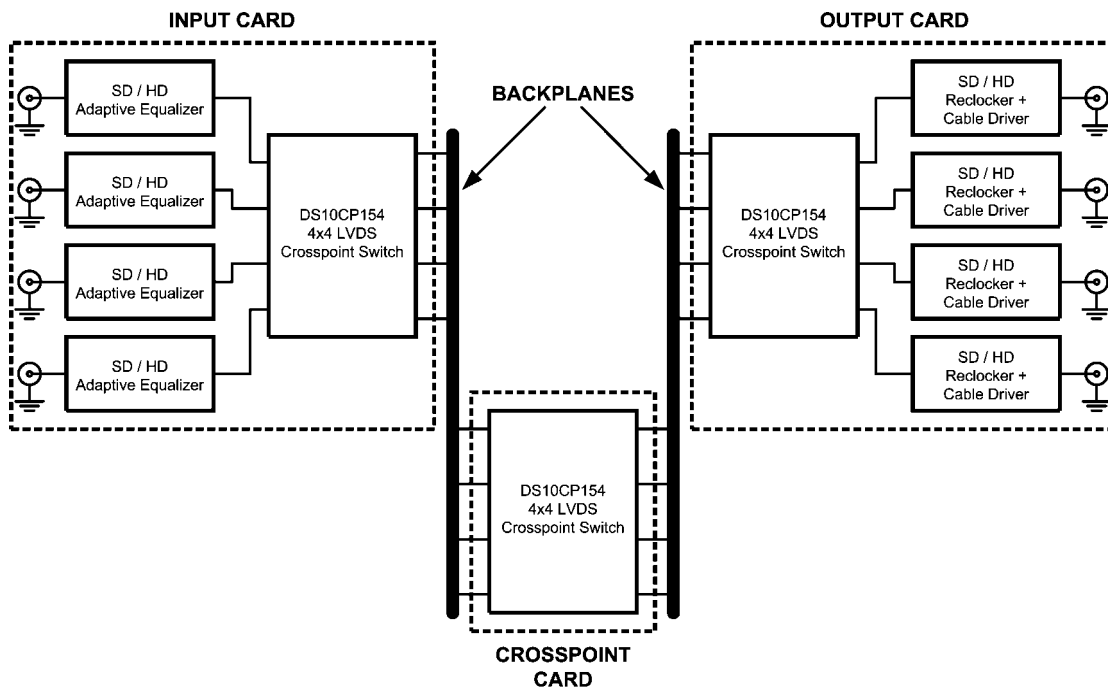

30006603

Ordering Code

NSID	Function
DS10CP154TSQ	Crosspoint Switch

Block Diagram

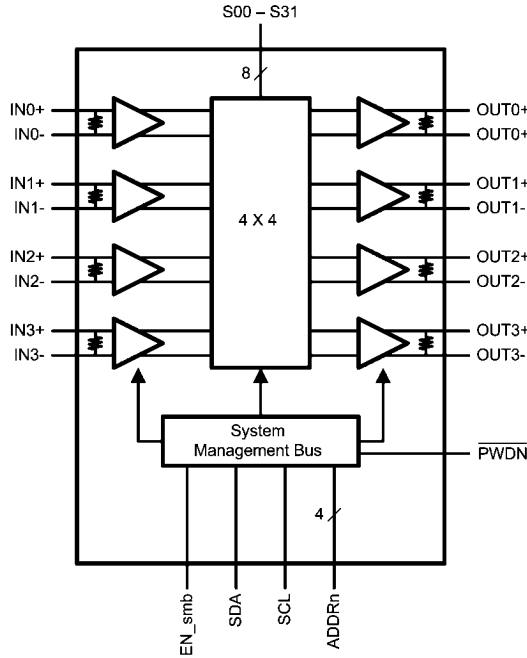

30006601

Connection Diagram

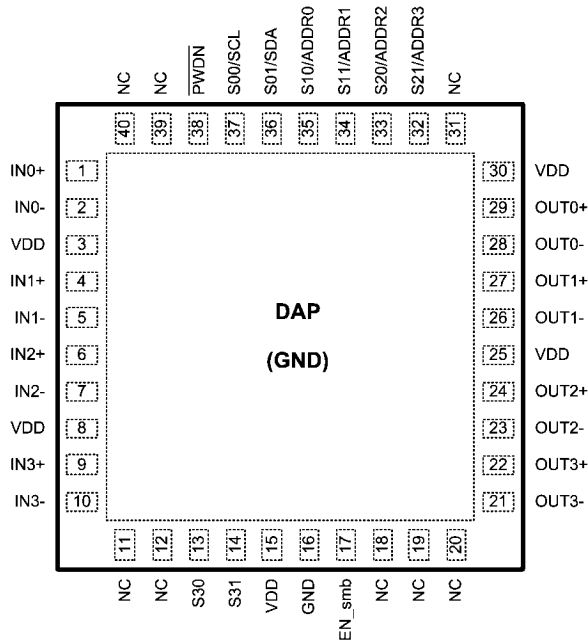

DS10CP154 Pin Diagram

30006602

Pin Descriptions

Pin Name	Pin Number	I/O, Type	Pin Description
IN0+, IN0- , IN1+, IN1- , IN2+, IN2- , IN3+, IN3-	1, 2, 4, 5, 6, 7, 9, 10	I, LVDS	Inverting and non-inverting high speed LVDS input pins.
OUT0+, OUT0- , OUT1+, OUT1- , OUT2+, OUT2- , OUT3+, OUT3-	29, 28, 27, 26, 24, 23, 22, 21	O, LVDS	Inverting and non-inverting high speed LVDS output pins.
EN_smb	17	I, LVCMOS	System Management Bus (SMBus) mode enable pin. The pin has an internal 20k pull down. When the pin is set to a [1], the device is in the SMBus mode. All SMBus registers are reset when the pin is toggled.
S00/SCL, S01/SDA	37, 36	I/O, LVCMOS	For EN_smb = [1], these pins select which LVDS input is routed to the OUT0. In the SMBus mode, when the EN_smb = [1], these pins are the SMBus clock input and data I/O pins respectively.
S10/ADDR0, S11/ADDR1	35, 34	I/O, LVCMOS	For EN_smb = [0], these pins select which LVDS input is routed to the OUT1. In the SMBus mode, when the EN_smb = [1], these pins are the User-Set SMBus Slave Address inputs.
S20/ADDR2, S21/ADDR3	33, 32	I/O, LVCMOS	For EN_smb = [0], these pins select which LVDS input is routed to the OUT2. In the SMBus mode, when the EN_smb = [1], these pins are the User-Set SMBus Slave Address inputs.
S30, S31	13, 14	I, LVCMOS	For EN_smb = [0], these pins select which LVDS input is routed to the OUT3. In the SMBus mode, when the EN_smb = [1], these pins are non-functional and should be tied to either logic [0] or [1].
PWDN	38	I, LVCMOS	For EN_smb = [0], this is the power down pin. When the PWDN is set to a [0], the device is in the power down mode. The SMBus circuitry can still be accessed provided the EN_smb pin is set to a [1]. In the SMBus mode, the device is powered up by either setting the PWDN pin to [1] OR by writing a [1] to the Control Register D[7] bit (SoftPWDN). The device will be powered down by setting the PWDN pin to [0] AND by writing a [0] to the Control Register D[7] bit (SoftPWDN).
NC	11, 12, 18, 19, 20, 31, 39, 40		No connect pins. May be left floating.
VDD	3, 8, 15,25, 30	Power	Power supply pins.
GND	16, DAP	Power	Ground pin and pad (DAP - die attach pad).

Absolute Maximum Ratings (Note 4)

If Military/Aerospace specified devices are required, please contact the National Semiconductor Sales Office/ Distributors for availability and specifications.

Supply Voltage	-0.3V to +4V
LVC MOS Input Voltage	-0.3V to ($V_{CC} + 0.3V$)
LVC MOS Output Voltage	-0.3V to ($V_{CC} + 0.3V$)
LVDS Input Voltage	-0.3V to +4V
LVDS Differential Input Voltage	0V to 1.0V
LVDS Output Voltage	-0.3V to +4V
LVDS Differential Output Voltage	0V to 1.0V
LVDS Output Short Circuit Current Duration	5 ms
Junction Temperature	+150°C
Storage Temperature Range	-65°C to +150°C
Lead Temperature Range	
Soldering (4 sec.)	+260°C
Maximum Package Power Dissipation at 25°C	
SQA Package	4.65W
Derate SQA Package	37.2 mW/°C above +25°C

Package Thermal Resistance

θ_{JA}	+26.9°C/W
θ_{JC}	+3.8°C/W

ESD Susceptibility

HBM (Note 1)	≥8 kV
MM (Note 2)	≥250V
CDM (Note 3)	≥1250V

Note 1: Human Body Model, applicable std. JESD22-A114C**Note 2:** Machine Model, applicable std. JESD22-A115-A**Note 3:** Field Induced Charge Device Model, applicable std. JESD22-C101-C**Recommended Operating Conditions**

	Min	Typ	Max	Units
Supply Voltage (V_{CC})	3.0	3.3	3.6	V
Receiver Differential Input Voltage (V_{ID})	0		1.0	V
Operating Free Air Temperature (T_A)	-40	+25	+85	°C
SMBus (SDA, SCL)			3.6	V

Electrical Characteristics

Over recommended operating supply and temperature ranges unless otherwise specified. (Notes 5, 6, 7)

Symbol	Parameter	Conditions	Min	Typ	Max	Units
LVC MOS DC SPECIFICATIONS						
V_{IH}	High Level Input Voltage		2.0		V_{DD}	V
V_{IL}	Low Level Input Voltage		GND		0.8	V
I_{IH}	High Level Input Current	$V_{IN} = 3.6V$ $V_{CC} = 3.6V$		0	±10	µA
			EN_smb pin	40	175	250
I_{IL}	Low Level Input Current	$V_{IN} = GND$ $V_{CC} = 3.6V$		0	±10	µA
V_{CL}	Input Clamp Voltage	$I_{CL} = -18 mA$, $V_{CC} = 0V$		-0.9	-1.5	V
V_{OL}	Low Level Output Voltage	$I_{OL} = 4 mA$, SDA pin			0.4	V
LVDS INPUT DC SPECIFICATIONS						
V_{ID}	Input Differential Voltage		0		1	V
V_{TH}	Differential Input High Threshold	$V_{CM} = +0.05V$ or $V_{CC} - 0.05V$		0	+100	mV
V_{TL}	Differential Input Low Threshold			-100	0	mV
V_{CMR}	Common Mode Voltage Range	$V_{ID} = 100 mV$	0.05		$V_{CC} - 0.05$	V
I_{IN}	Input Current	$V_{IN} = 3.6V$ or $0V$ $V_{CC} = 3.6V$ or $0V$		±1	±10	µA
C_{IN}	Input Capacitance	Any LVDS Input Pin to GND		1.7		pF
R_{IN}	Input Termination Resistor	Between IN+ and IN-		100		Ω

Symbol	Parameter	Conditions	Min	Typ	Max	Units
LVDS OUTPUT DC SPECIFICATIONS						
V_{OD}	Differential Output Voltage	$R_L = 100\Omega$	250	350	450	mV
ΔV_{OD}	Change in Magnitude of V_{OD} for Complimentary Output States		-35		35	mV
V_{OS}	Offset Voltage	$R_L = 100\Omega$	1.05	1.2	1.375	V
ΔV_{OS}	Change in Magnitude of V_{OS} for Complimentary Output States		-35		35	mV
I_{OS}	Output Short Circuit Current (Note 8)	OUT to GND		-25	-55	mA
		OUT to V_{CC}		7	55	mA
C_{OUT}	Output Capacitance	Any LVDS Output Pin to GND		1.2		pF
R_{OUT}	Output Termination Resistor	Between OUT+ and OUT-		100		Ω
SUPPLY CURRENT						
I_{CC1}	Supply Current	$\overline{PWDN} = 0$		40	50	mA
I_{CC2}	Supply Current	$\overline{PWDN} = 1$ Broadcast Mode (1:4)		103	125	mA
I_{CC3}	Supply Current	$\overline{PWDN} = 1$ Quad Buffer Mode (4:4)		115	140	mA

Note 4: "Absolute Maximum Ratings" indicate limits beyond which damage to the device may occur, including inoperability and degradation of device reliability and/or performance. Functional operation of the device and/or non-degradation at the Absolute Maximum Ratings or other conditions beyond those indicated in the Recommended Operating Conditions is not implied. The Recommended Operating Conditions indicate conditions at which the device is functional and the device should not be operated beyond such conditions.

Note 5: The Electrical Characteristics tables list guaranteed specifications under the listed Recommended Operating Conditions except as otherwise modified or specified by the Electrical Characteristics Conditions and/or Notes. Typical specifications are estimations only and are not guaranteed.

Note 6: Current into device pins is defined as positive. Current out of device pins is defined as negative. All voltages are referenced to ground except V_{OD} and ΔV_{OD} .

Note 7: Typical values represent most likely parametric norms for $V_{CC} = +3.3V$ and $T_A = +25^\circ C$, and at the Recommended Operation Conditions at the time of product characterization and are not guaranteed.

Note 8: Output short circuit current (I_{OS}) is specified as magnitude only, minus sign indicates direction only.

AC Electrical Characteristics

Over recommended operating supply and temperature ranges unless otherwise specified. (Notes 9, 10)

Symbol	Parameter	Conditions	Min	Typ	Max	Units	
LVDS OUTPUT AC SPECIFICATIONS (Note 11)							
t_{PLHD}	Differential Propagation Delay Low to High	$R_L = 100\Omega$		500	675	ps	
t_{PHLD}	Differential Propagation Delay High to Low			460	675	ps	
t_{SKD1}	Pulse Skew $ t_{PLHD} - t_{PHLD} $, (Note 12)			40	100	ps	
t_{SKD2}	Channel to Channel Skew, (Note 13)			40	125	ps	
t_{SKD3}	Part to Part Skew, (Note 14)			50	225	ps	
t_{LHT}	Rise Time	$R_L = 100\Omega$		145	350	ps	
t_{HLT}	Fall Time			145	350	ps	
t_{ON}	Power Up Time	Time from $\overline{PWDN} = LH$ to OUT_n active		7	20	μs	
t_{OFF}	Power Down Time	Time from $\overline{PWDN} = HL$ to OUT_n inactive		6	25	ns	
t_{SEL}	Select Time	Time from $S_n = LH$ or HL to new signal at OUT_n		8	12	ns	
JITTER PERFORMANCE (Note 11)							
t_{RJ1}	Random Jitter (RMS Value) (Note 15)	$V_{ID} = 350\text{ mV}$ $V_{CM} = 1.2\text{V}$ Clock (RZ)	135 MHz		1	2.0	ps
t_{RJ2}			311 MHz		0.5	1.2	ps
t_{RJ3}			503 MHz		0.5	1.0	ps
t_{RJ4}			750 MHz		0.5	1.0	ps
t_{DJ1}	Deterministic Jitter (Peak to Peak Value) (Note 16)	$V_{ID} = 350\text{ mV}$ $V_{CM} = 1.2\text{V}$ K28.5 (NRZ)	270 Mbps		7	30	ps
t_{DJ2}			622 Mbps		12	26	ps
t_{DJ3}			1.06 Gbps		9	24	ps
t_{DJ4}			1.5 Gbps		12	28	ps
t_{TJ1}	Total Jitter (Peak to Peak Value) (Note 17)	$V_{ID} = 350\text{ mV}$ $V_{CM} = 1.2\text{V}$ PRBS-23 (NRZ)	270 mbps		0.008	0.036	UI_{P-P}
t_{TJ2}			622 Mbps		0.007	0.043	UI_{P-P}
t_{TJ3}			1.06Gbps		0.008	0.064	UI_{P-P}
t_{TJ4}			1.5 Gbps		0.007	0.072	UI_{P-P}

Symbol	Parameter	Conditions	Min	Typ	Max	Units
SMBus AC SPECIFICATIONS						
f_{SMB}	SMBus Operating Frequency		10		100	kHz
t_{BUF}	Bus free time between Stop and Start Conditions		4.7			μs
$t_{HD:SDA}$	Hold time after (Repeated) Start Condition. After this period, the first clock is generated.		4.0			μs
$t_{SU:SDA}$	Repeated Start Condition setup time.		4.7			μs
$t_{SU:SDO}$	Stop Condition setup time		4.0			μs
$t_{HD:DAT}$	Data hold time		300			ns
$t_{SU:DAT}$	Data setup time		250			ns
$t_{TIMEOUT}$	Detect clock low timeout		25		35	ms
t_{LOW}	Clock low period		4.7			μs
t_{HIGH}	Clock high period		4.0		50	μs
t_{POR}	Time in which a device must be operational after power-on reset				500	ms

Note 9: The Electrical Characteristics tables list guaranteed specifications under the listed Recommended Operating Conditions except as otherwise modified or specified by the Electrical Characteristics Conditions and/or Notes. Typical specifications are estimations only and are not guaranteed.

Note 10: Typical values represent most likely parametric norms for $V_{CC} = +3.3V$ and $T_A = +25^\circ C$, and at the Recommended Operation Conditions at the time of product characterization and are not guaranteed.

Note 11: Specification is guaranteed by characterization and is not tested in production.

Note 12: t_{SKD1} , $|t_{PLHD} - t_{PHLD}|$, Pulse Skew, is the magnitude difference in differential propagation delay time between the positive going edge and the negative going edge of the same channel.

Note 13: t_{SKD2} , Channel to Channel Skew, is the difference in propagation delay (t_{PLHD} or t_{PHLD}) among all output channels in Broadcast mode (any one input to all outputs).

Note 14: t_{SKD3} , Part to Part Skew, is defined as the difference between the minimum and maximum differential propagation delays. This specification applies to devices at the same V_{CC} and within $5^\circ C$ of each other within the operating temperature range.

Note 15: Measured on a clock edge with a histogram and an accumulation of 1500 histogram hits. Input stimulus jitter is subtracted geometrically.

Note 16: Tested with a combination of the 110000101 (K28.5+ character) and 0011111010 (K28.5- character) patterns. Input stimulus jitter is subtracted algebraically.

Note 17: Measured on an eye diagram with a histogram and an accumulation of 3500 histogram hits. Input stimulus jitter is subtracted.

DC Test Circuits

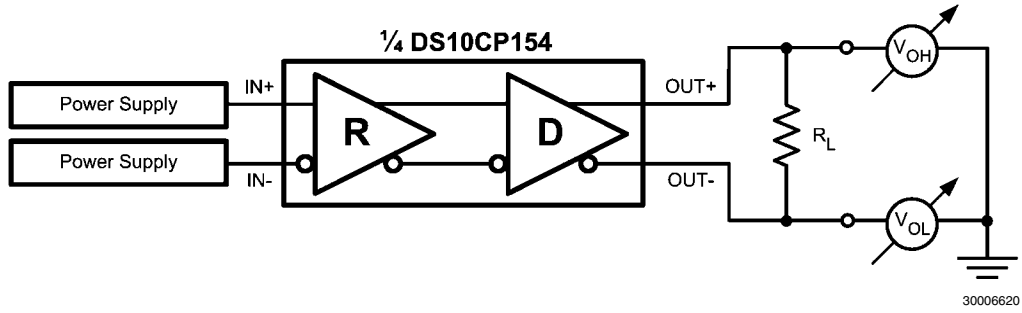

FIGURE 1. Differential Driver DC Test Circuit

AC Test Circuits and Timing Diagrams

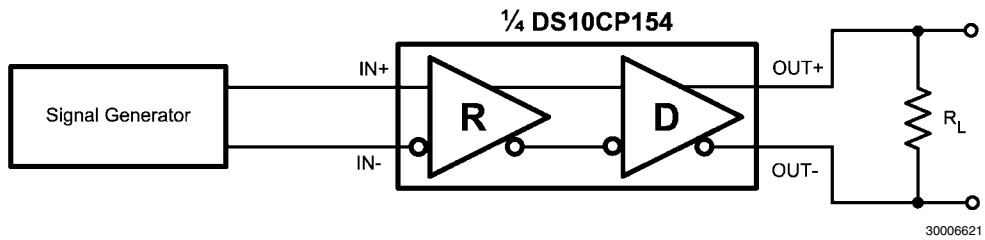

FIGURE 2. Differential Driver AC Test Circuit

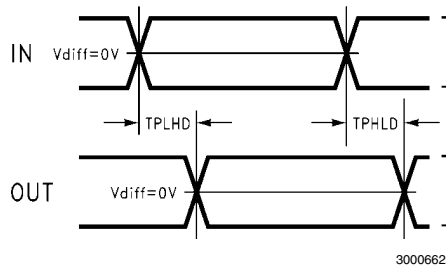

FIGURE 3. Propagation Delay Timing Diagram

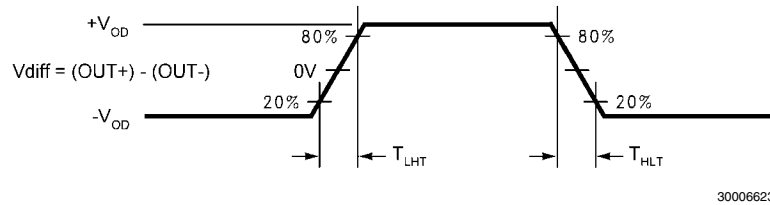

FIGURE 4. LVDS Output Transition Times

Functional Description

The DS10CP154 is a 1.5 Gbps 4x4 LVDS digital crosspoint switch optimized for high-speed signal routing and switching over lossy FR-4 printed circuit board backplanes and balanced cables. The DS10CP154 operates in two modes: Pin Mode (EN_smb = 0) and SMBus Mode (EN_smb = 1).

When in the Pin Mode, the switch is fully configurable with external pins. This is possible with two input select pins per output (e.g. S00 and S01 pins for OUT0).

In the Pin Mode, feedback from the $\overline{\text{LOS}}$ (Loss Of Signal) monitor circuitry is not available (there is not an $\overline{\text{LOS}}$ output pin).

When in the SMBus Mode, the full switch configuration and SoftPWRN can be programmed via the SMBus interface. In addition, by using the SMBus interface, a user can obtain the feedback from the built-in $\overline{\text{LOS}}$ circuitry which detects an open inputs fault condition.

In the SMBus Mode, the S00 and S01 pins become SMBus clock (SCL) input and data (SDA) input pins respectively; the S10, S11, S21 and S21 pins become the User-Set SMBus Slave Address input pins (ADDR0, 1, 2 and 3) while the S30

and S31 pins become non-functional (tying these two pins to either H or L is recommended if the device will function only in the SMBus mode).

In the SMBus Mode, the $\overline{\text{PWRN}}$ pin remains functional. How this pin functions in each mode is detailed in the following sections.

DS10CP154 OPERATION IN THE PIN MODE

Power Up

In the Pin Mode, when the power is applied to the device power supply pins, the DS10CP154 enters the Power Up mode when the $\overline{\text{PWRN}}$ pin is set to logic H. When in the Power Down mode ($\overline{\text{PWRN}}$ pin is set to logic L), all circuitry is shut down except the minimum required circuitry for the $\overline{\text{LOS}}$ and SMBus Slave operation.

Switch Configuration

In the Pin Mode, the DS10CP154 operates as a fully pin-configurable crosspoint switch. The following truth tables illustrate how the switch can be configured with external pins.

Switch Configuration Truth Tables

TABLE 1. Input Select Pins Configuration for the Output OUT0

S01	S00	INPUT SELECTED
0	0	IN0
0	1	IN1
1	0	IN2
1	1	IN3

TABLE 2. Input Select Pins Configuration for the Output OUT1

S11	S10	INPUT SELECTED
0	0	IN0
0	1	IN1
1	0	IN2
1	1	IN3

TABLE 3. Input Select Pins Configuration for the Output OUT2

S21	S20	INPUT SELECTED
0	0	IN0
0	1	IN1
1	0	IN2
1	1	IN3

TABLE 4. Input Select Pins Configuration for the Output OUT3

S31	S30	INPUT SELECTED
0	0	IN0
0	1	IN1
1	0	IN2
1	1	IN3

DS10CP154 OPERATION IN THE SMBUS MODE

The DS10CP154 operates as a slave on the System Management Bus (SMBus) when the EN_smb pin is set to a high (1). Under these conditions, the SCL pin is a clock input while the SDA pin is a serial data input pin.

slave address are hard wired inside the DS10CP154 and are "101". The four least significant bits of the address are assigned to pins ADDR3-ADDR0 and are set by connecting these pins to GND for a low (0) or to VCC for a high (1). The complete slave address is shown in the following table:

Device Address

Based on the SMBus 2.0 specification, the DS10CP154 has a 7-bit slave address. The three most significant bits of the

TABLE 5. DS10CP154 Slave Address

1	0	1	ADDR3	ADDR2	ADDR1	ADDR0
MSB						LSB

This slave address configuration allows up to sixteen DS10CP154 devices on a single SMBus bus.

Transfer of Data via the SMBus

During normal operation the data on SDA must be stable during the time when SCK is high.

There are three unique states for the SMBus:

START: A HIGH to LOW transition on SDA while SCK is high indicates a message START condition.

STOP: A LOW to HIGH transition on SDA while SCK is high indicates a message STOP condition.

IDLE: If SCK and SDA are both high for a time exceeding tBUF from the last detected STOP condition or if they are high for a total exceeding the maximum specification for tHIGH then the bus will transfer to the IDLE state.

SMBus Transactions

A transaction begins with the host placing the DS10CP154 SMBus into the START condition, then a byte (8 bits) is transferred, MSB first, followed by a ninth ACK bit. ACK bits are '0' to signify an ACK, or '1' to signify NACK, after this the host holds the SCL line low, and waits for the receiver to raise the SDA line as an ACKnowledge that the byte has been received.

Writing to a Register

To write a data value to a register in the DS10CP154, the host writes three bytes to the DS10CP154. The first byte is the device address—the device address is a 7 bit value, and if writing to the DS10CP154 the last bit (LSB) is set to '0' to signify that the operation is a write. The second byte written is the register address, and the third byte written is the data to be written into the addressed register. If additional data writes are performed, the register address is automatically incremented. At the end of the write cycle the host places the bus in the STOP state.

Reading From a Register

To read the data value from a register, first the host writes the device address with the LSB set to a '0' denoting a write, then the register address is written to the device. The host then reasserts the START condition, and writes the device address once again, but this time with the LSB set to a '1' denoting a read, and following this the DS10CP154 will drive the SDA line with the data from the addressed register. The host indicates that it has finished reading the data by asserting a '1' for the ACK bit. After reading the last byte, the host will assert a '0' for NACK to indicate to the DS10CP154 that it does not require any more data.

REGISTER DESCRIPTIONS

There are three data registers in the DS10CP154 accessible via the SMBus interface.

TABLE 6. DS10CP154 SMBus Data Registers

Address (hex)	Name	Access	Description
0	Switch Configuration	R/W	Switch Configuration Register
3	Control	R/W	Powerdown, $\overline{\text{LOS}}$ Enable and Pin Control Register
4	$\overline{\text{LOS}}$	RO	Loss Of Signal ($\overline{\text{LOS}}$) Reporting Register

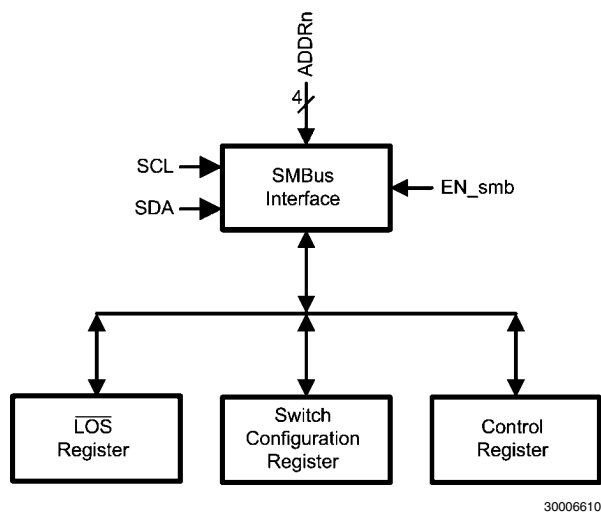

30006610

FIGURE 5. DS10CP154 Registers Block Diagram

SWITCH CONFIGURATION REGISTER

The Switch Configuration register is utilized to configure the switch. The following two tables show the Switch Configuration Register mapping and associated truth table.

Bit	Default	Bit Name	Access	Description
D[1:0]	00	Input Select 0	R/W	Selects which input is routed to the OUT0.
D[3:2]	00	Input Select 1	R/W	Selects which input is routed to the OUT1.
D[5:4]	00	Input Select 2	R/W	Selects which input is routed to the OUT2.
D[7:6]	00	Input Select 3	R/W	Selects which input is routed to the OUT3.

TABLE 7. Switch Configuration Register Truth Table

D1	D0	Input Routed to the OUT0
0	0	IN0
0	1	IN1
1	0	IN2
1	1	IN3

The truth tables for the OUT1, OUT2, and OUT3 outputs are identical to this table.

The switch configuration logic has a SmartPWDN circuitry which automatically optimizes the device's power consumption based on the switch configuration (i.e. It places unused I/O blocks and other unused circuitry in the power down state).

CONTROL REGISTER

The Control register enables $\overline{\text{SoftPWN}}$ control, individual output power down ($\overline{\text{PWNn}}$) control and $\overline{\text{LOS}}$ Circuitry Enable control via the SMBus. The following table shows the register mapping.

Bit	Default	Bit Name	Access	Description
D[3:0]	1111	$\overline{\text{PWNn}}$	R/W	Writing a [0] to the bit D[n] will power down the output OUTn when either the $\overline{\text{PWN}}$ pin OR the Control Register bit D[7] ($\overline{\text{SoftPWN}}$) is set to a high [1].
D[4]	x	n/a	R/W	Undefined.
D[5]	x	n/a	R/W	Undefined.
D[6]	0	$\text{EN_}\overline{\text{LOS}}$	R/W	Writing a [1] to the bit D[6] will enable the $\overline{\text{LOS}}$ circuitry and receivers on all four inputs. The SmartPWN circuitry will not disable any of the inputs nor any supporting $\overline{\text{LOS}}$ circuitry depending on the switch configuration.
D[7]	0	$\overline{\text{SoftPWN}}$	R/W	Writing a [0] to the bit D[7] will place the device into the power down mode. This pin is ORed together with the $\overline{\text{PWN}}$ pin.

TABLE 8. DS10CP154 Power Modes Truth Table

$\overline{\text{PWN}}$	$\overline{\text{SoftPWN}}$	$\overline{\text{PWNn}}$	DS25CP104 Power Mode
0	0	x	Power Down Mode. In this mode, all circuitry is shut down except the minimum required circuitry for the $\overline{\text{LOS}}$ and SMBus Slave operation. The SMBus circuitry allows enabling the $\overline{\text{LOS}}$ circuitry and receivers on all inputs in this mode by setting the $\text{EN_}\overline{\text{LOS}}$ bit to a [1].
0	1	x	Power Up Mode. In this mode, the SmartPWN circuitry will automatically power down any unused I/O and logic blocks and other supporting circuitry depending on the switch configuration. An output will be enabled only when the SmartPWN circuitry indicates that that particular output is needed for the particular switch configuration and the respective $\overline{\text{PWNn}}$ bit has logic high [1]. An input will be enabled when the SmartPWN circuitry indicates that that particular input is needed for the particular switch configuration or the $\text{EN_}\overline{\text{LOS}}$ bit is set to a [1].
1	0	x	
1	1	x	

$\overline{\text{LOS}}$ REGISTER

The $\overline{\text{LOS}}$ register reports an open inputs fault condition for each of the inputs. The following table shows the register mapping.

Bit	Default	Bit Name	Access	Description
D[0]	0	$\overline{\text{LOS0}}$	RO	Reading a [0] from the bit D[0] indicates an open inputs fault condition on the IN0. A [1] indicates presence of a valid signal.
D[1]	0	$\overline{\text{LOS1}}$	RO	Reading a [0] from the bit D[1] indicates an open inputs fault condition on the IN1. A [1] indicates presence of a valid signal.
D[2]	0	$\overline{\text{LOS2}}$	RO	Reading a [0] from the bit D[2] indicates an open inputs fault condition on the IN2. A [1] indicates presence of a valid signal.
D[3]	0	$\overline{\text{LOS3}}$	RO	Reading a [0] from the bit D[3] indicates an open inputs fault condition on the IN3. A [1] indicates presence of a valid signal.
D[7:4]	0000	Reserved	RO	Reserved for future use. Returns undefined value when read.

INPUT INTERFACING

The DS10CP154 accepts differential signals and allows simple AC or DC coupling. With a wide common mode range, the DS10CP154 can be DC-coupled with all common differential drivers (i.e. LVPECL, LVDS, CML). The following three figures illustrate typical DC-coupled interface to common differential drivers. Note that the DS10CP154 inputs are internally terminated with a 100Ω resistor.

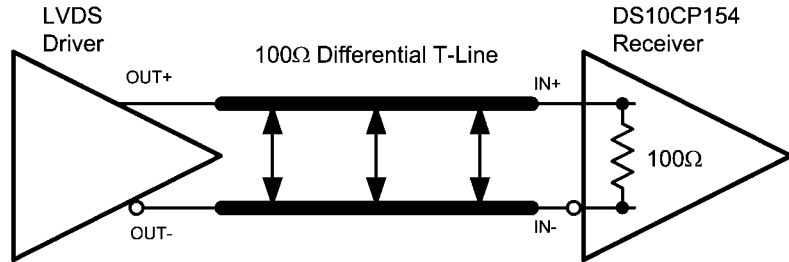

Typical LVDS Driver DC-Coupled Interface to DS10CP154 Input

30006631

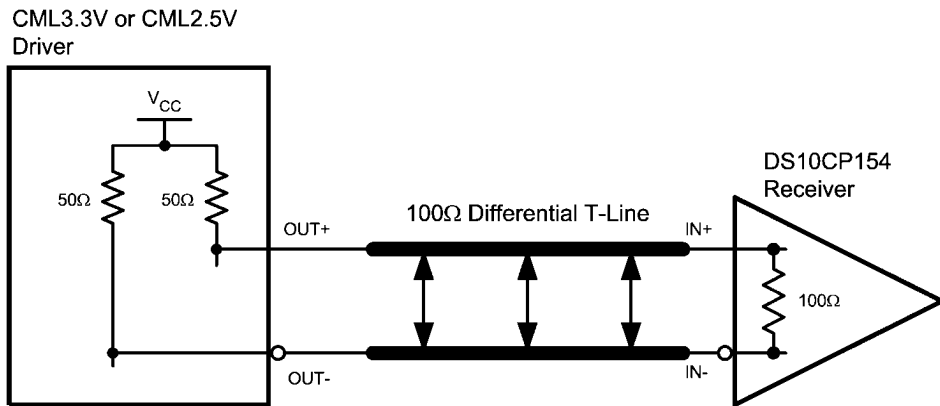

Typical CML Driver DC-Coupled Interface to DS10CP154 Input

30006632

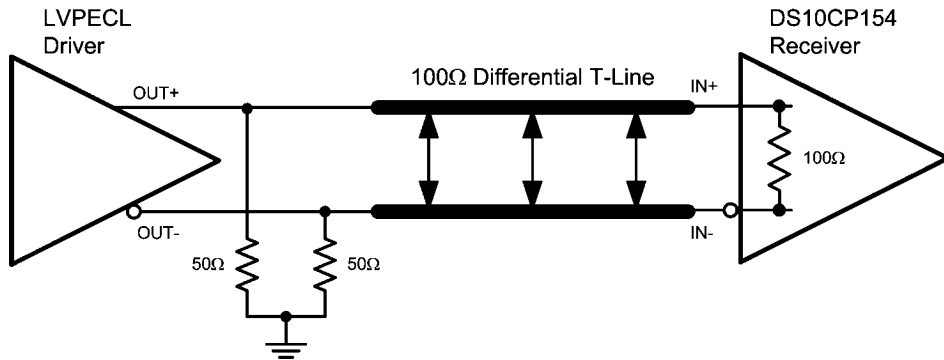

Typical LVPECL Driver DC-Coupled Interface to DS10CP154 Input

30006633

OUTPUT INTERFACING

The DS10CP154 outputs signals that are compliant to the LVDS standard. Its outputs can be DC-coupled to most common differential receivers. The following figure illustrates typical DC-coupled interface to common differential receivers and assumes that the receivers have high impedance inputs. While most differential receivers have a common mode input range that can accommodate LVDS compliant signals, it is recommended to check respective receiver's data sheet prior to implementing the suggested interface implementation.

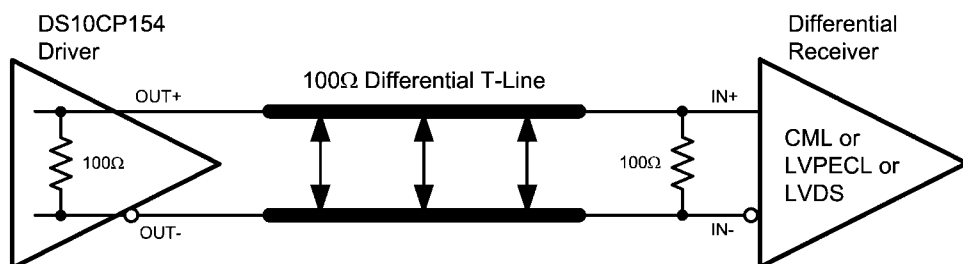

30006634

Typical DS10CP154 Output DC-Coupled Interface to an LVDS, CML or LVPECL Receiver

Physical Dimensions inches (millimeters) unless otherwise noted

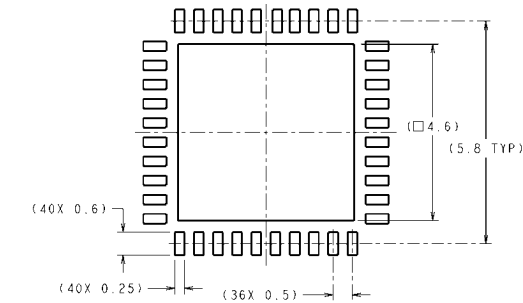

RECOMMENDED LAND PATTERN

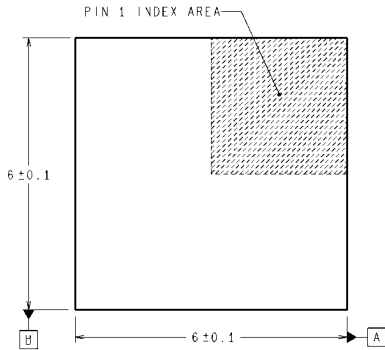

DIMENSIONS ARE IN MILLIMETERS
DIMENSIONS IN () FOR REFERENCE ONLY

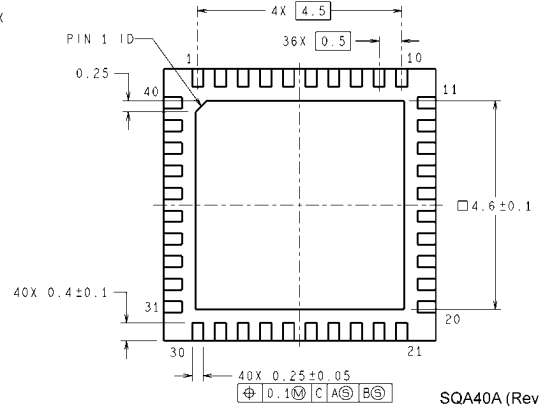
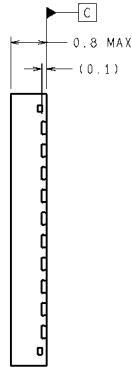
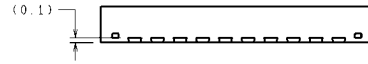

⊕ 0.1M | C A S B S

SQA40A (Rev B)

Order Number DS10CP154TSQ
NS Package Number SQA40A
(See AN-1187 for PCB Design and Assembly Recommendations)

Notes

Notes

THE CONTENTS OF THIS DOCUMENT ARE PROVIDED IN CONNECTION WITH NATIONAL SEMICONDUCTOR CORPORATION ("NATIONAL") PRODUCTS. NATIONAL MAKES NO REPRESENTATIONS OR WARRANTIES WITH RESPECT TO THE ACCURACY OR COMPLETENESS OF THE CONTENTS OF THIS PUBLICATION AND RESERVES THE RIGHT TO MAKE CHANGES TO SPECIFICATIONS AND PRODUCT DESCRIPTIONS AT ANY TIME WITHOUT NOTICE. NO LICENSE, WHETHER EXPRESS, IMPLIED, ARISING BY ESTOPPEL OR OTHERWISE, TO ANY INTELLECTUAL PROPERTY RIGHTS IS GRANTED BY THIS DOCUMENT.

TESTING AND OTHER QUALITY CONTROLS ARE USED TO THE EXTENT NATIONAL DEEMS NECESSARY TO SUPPORT NATIONAL'S PRODUCT WARRANTY. EXCEPT WHERE MANDATED BY GOVERNMENT REQUIREMENTS, TESTING OF ALL PARAMETERS OF EACH PRODUCT IS NOT NECESSARILY PERFORMED. NATIONAL ASSUMES NO LIABILITY FOR APPLICATIONS ASSISTANCE OR BUYER PRODUCT DESIGN. BUYERS ARE RESPONSIBLE FOR THEIR PRODUCTS AND APPLICATIONS USING NATIONAL COMPONENTS. PRIOR TO USING OR DISTRIBUTING ANY PRODUCTS THAT INCLUDE NATIONAL COMPONENTS, BUYERS SHOULD PROVIDE ADEQUATE DESIGN, TESTING AND OPERATING SAFEGUARDS.

EXCEPT AS PROVIDED IN NATIONAL'S TERMS AND CONDITIONS OF SALE FOR SUCH PRODUCTS, NATIONAL ASSUMES NO LIABILITY WHATSOEVER, AND NATIONAL DISCLAIMS ANY EXPRESS OR IMPLIED WARRANTY RELATING TO THE SALE AND/OR USE OF NATIONAL PRODUCTS INCLUDING LIABILITY OR WARRANTIES RELATING TO FITNESS FOR A PARTICULAR PURPOSE, MERCHANTABILITY, OR INFRINGEMENT OF ANY PATENT, COPYRIGHT OR OTHER INTELLECTUAL PROPERTY RIGHT.

LIFE SUPPORT POLICY

NATIONAL'S PRODUCTS ARE NOT AUTHORIZED FOR USE AS CRITICAL COMPONENTS IN LIFE SUPPORT DEVICES OR SYSTEMS WITHOUT THE EXPRESS PRIOR WRITTEN APPROVAL OF THE CHIEF EXECUTIVE OFFICER AND GENERAL COUNSEL OF NATIONAL SEMICONDUCTOR CORPORATION. As used herein:

Life support devices or systems are devices which (a) are intended for surgical implant into the body, or (b) support or sustain life and whose failure to perform when properly used in accordance with instructions for use provided in the labeling can be reasonably expected to result in a significant injury to the user. A critical component is any component in a life support device or system whose failure to perform can be reasonably expected to cause the failure of the life support device or system or to affect its safety or effectiveness.

National Semiconductor and the National Semiconductor logo are registered trademarks of National Semiconductor Corporation. All other brand or product names may be trademarks or registered trademarks of their respective holders.

Copyright© 2007 National Semiconductor Corporation

For the most current product information visit us at www.national.com



**National Semiconductor
Americas Customer
Support Center**
Email:
new.feedback@nsc.com
Tel: 1-800-272-9959

**National Semiconductor Europe
Customer Support Center**
Fax: +49 (0) 180-530-85-86
Email: europe.support@nsc.com
Deutsch Tel: +49 (0) 69 9508 6208
English Tel: +49 (0) 870 24 0 2171
Français Tel: +33 (0) 1 41 91 8790

**National Semiconductor Asia
Pacific Customer Support Center**
Email: ap.support@nsc.com

**National Semiconductor Japan
Customer Support Center**
Fax: 81-3-5639-7507
Email: jpn.feedback@nsc.com
Tel: 81-3-5639-7560