

POWERTIP TECH. CORP.

DISPLAY DEVICES FOR BETTER ELECTRONIC DESIGN

Specification For Approval

Customer : _____

Model Type : LCD Module

Sample Code : _____

Mass Production Code : PG12032LRU-DNN-B

Edit : _____

Customer Sign	Sales Sign	Approved By	Prepared By

CONTENTS

1.SPECIFICATIONS

- 1.1 Features
- 1.2 Mechanical Specifications
- 1.3 Absolute Maximum Ratings
- 1.4 DC Electrical Characteristics
- 1.5 Optical Characteristics
- 1.6 Backlight Characteristics

2.MODULE STRUCTURE

- 2.1 Counter Drawing
- 2.2 Interface Pin Description
- 2.3 Timing Characteristics
- 2.4 Display Command



POWERTIP TECHNOLOGY CORPORATION

DISPLAY DEVICES FOR BETTER ELECTRONIC DESIGN

1. SPECIFICATIONS

1.1 Features

- Full dot-matrix structure with 120 dots *32 dots
- 1/32 Duty, 1/5 bias
- STN LCD, positive
- Transflective LCD, yellow green
- 6 o'clock viewing angle
- 8 bits parallel data input
- Built-in LED backlight

1.2 Mechanical Specifications

- Outline dimension : 68.1mm(L)*32.9mm(W)*8.1mm max.(H)
- Viewing area : 62.0mm *22.5mm
- Active area : 56.35mm *20.75mm
- Dot size : 0.42mm *0.60mm
- Dot pitch : 0.47mm *0.65mm

1.3 Absolute Maximum Ratings

Item	Symbol	Conditions	Min.	Max.	Unit
Power supply Voltage	VDD	-	0	7.0	V
LCD drive Supply voltage	VDD-V0	-	-	16.5	V
Input voltage	VIN	-	VSS-0.3	0.3	V
Operating temperature	TOPR	-	0	40	°C
Storage temperature	TSTG	-	-20	60	°C
Humidity*1	HD	-	-	90	%RH

1.4 DC Electrical Characteristics

VDD=5V+0.5, VSS=0V, Ta=25°C

Item	Symbol	Condition	Min.	Typ.	Max.	Unit
Logic Supply voltage	VDD	-	4.5	5.0	5.5	V
“H” input voltage	VIH	-	0.8VDD	-	VDD	V
“L” input voltage	VIL	-	VSS	-	0.2VDD	V
Supply current	IDD	VDD=5V	-	0.2	-	mA
LCD driving voltage	VOP	VDD-V0	-	5.3	-	V

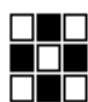

POWERTIP TECHNOLOGY CORPORATION
DISPLAY DEVICES FOR BETTER ELECTRONIC DESIGN

1.5 Optical Characteristics

1/32 duty, 1/5 bias, Vopr=6.0V, Ta=25°C

Item	Symbol	Conditions	Min.	Typ.	Max	Reference
Viewing angle	θ	$C \geq 2.0, \varnothing = 0^\circ$	30°	-	-	Notes 1 & 2
Contrast	C	$\theta = 5^\circ, \varnothing = 0^\circ$	-	3	-	Note 3
Response time(rise)	tr	$\theta = 5^\circ, \varnothing = 0^\circ$	-	150ms	225ms	Note 4
Response time(fall)	tf	$\theta = 5^\circ, \varnothing = 0^\circ$	-	300ms	450ms	Note 4

Note 1: Definition of angles θ and \varnothing

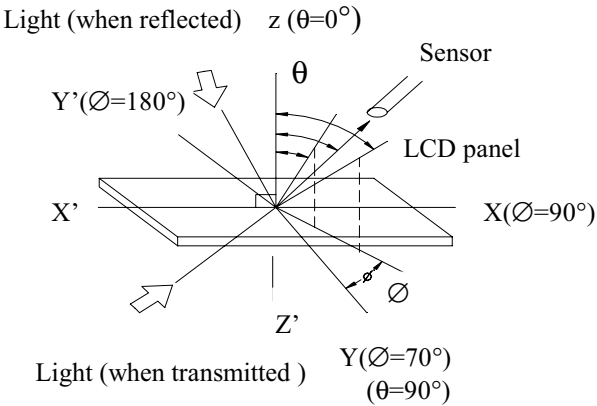

Note 2: Definition of viewing angles θ_1 and θ_2

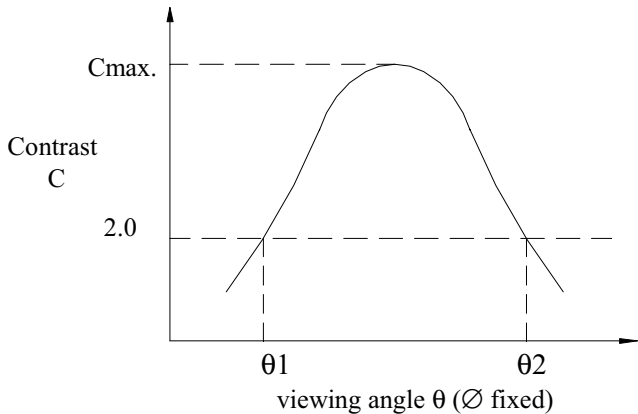

Note : Optimum viewing angle with the naked eye and viewing angle θ at Cmax. Above are not always the same

Note 3: Definition of contrast C

$$C = \frac{\text{Brightness (reflection) of unselected dot (B2)}}{\text{Brightness (reflection) of selected dot (B1)}}$$

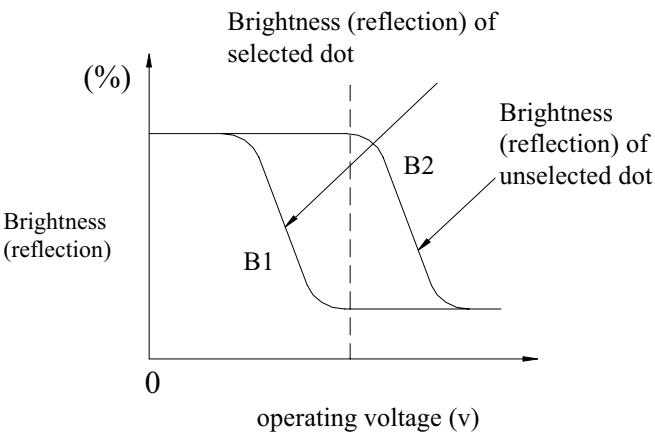

Note 4: Definition of response time

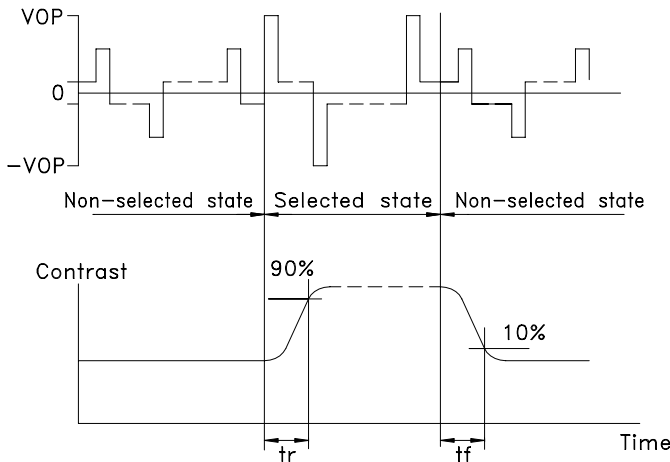

Note: Measured with a transmissive LCD panel which is displayed 1 cm²

V_{OPR} : Operating voltage f_{FRM} : Frame frequency
 t_R : Response time (rise) t_F : Response time (fall)

1.6 Backlight Characteristic

The LCD Module is backlight using a LED panel

- Maximum Ratings

Item	Symbol	Conditions	Min.	Max.	Unit
Forward current	IF	TA=25°C	-	250	MA
Reverse voltage	VR	TA=25°C	-	8	V
Power dissipation	PO	TA=25°C	-	1.15	W
Operating Temperature	TOPR	-	-20	70	°C
Storage temperature	TSTG	-	-40	80	°C

- Electrical Ratings

Item	Symbol	Condition	Min.	Typ.	Max.	Unit
Forward voltage	VF	IF=100mA	-	4.0	4.4	V
Reverse current	IR	VR=8V	-	-	0.2	mA
Luminous intensity	IV	IF=100mA	24	30	-	cd/m ²
Wavelength	λp	IF=100mA	565	-	571	nm
Color	Yellow Green					



2. MODULE STRUCTURE

2.1 Counter Drawing

*See Appendix

2.2 Interface Pin Description

Pin No	Symbol	Function
1	GND	Signal ground for LCDM and LED backlight
2	VDD	Power supply for logic (+5V) for LCDM and LED backlight
3	VO	Cantrast adjust
4	AO	Register selection input High =Data register Low =Instruction register (for write) Busy flag address counter (for read)
5	R/ \overline{W}	$\overline{R/W}$ signal input is used to select the read/write mode High =Read mode, Low =Write mode
6	E1	Chip enable active "L", segment1~segment 60
7	E2	Chip enable active "L", segment61~segment 120
8	NC	No connection
9-12	DB0~DB3	Four low order bi-directional three-state data bus lines. Used for data transfer between the MPU and the LCD module. These four are not used during 4-bit operation.
13-16	DB4~DB7	Four high order bi-directional three-state data bus lines. Used for data transfer between the MPU

Contrast Adjust

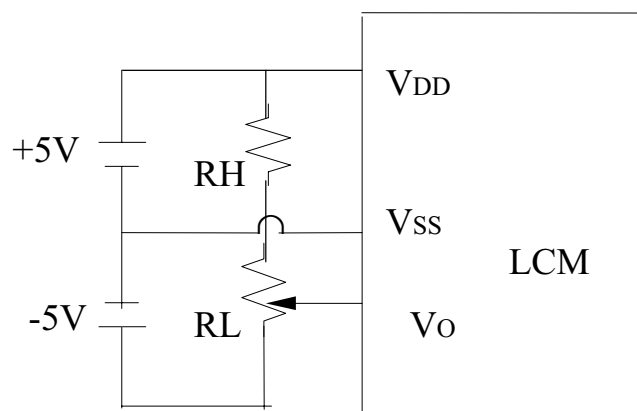

2.3 Timing Characteristics

• MPU Bus Read/Write I (80-family MPU)

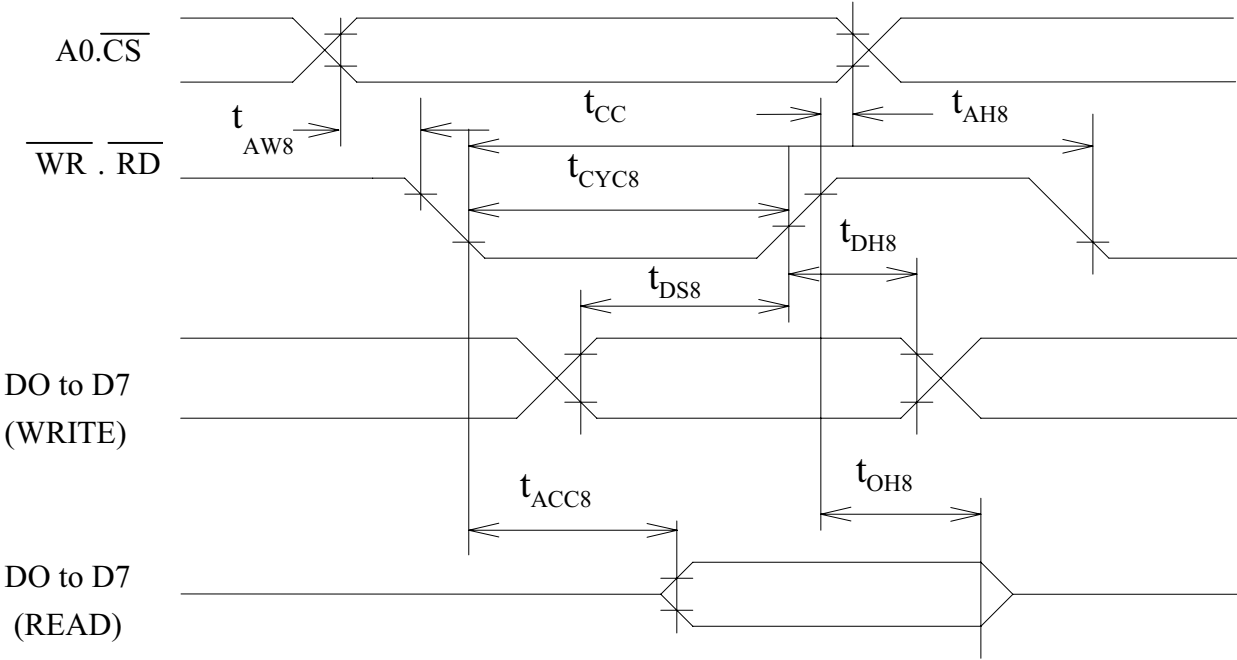

• MPU Bus Read/Write II (68-family MPU)

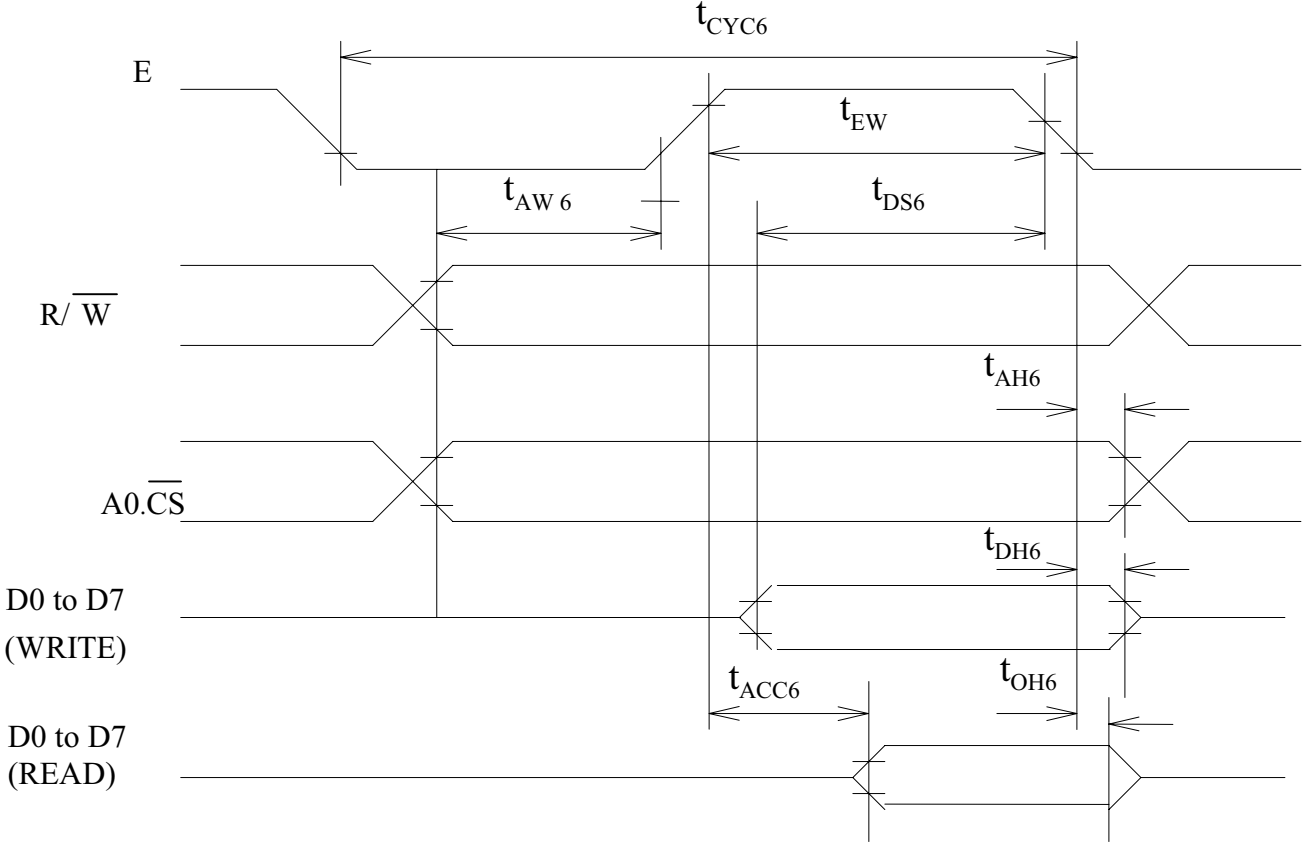

•MPU Bus Read/Write I (80-family MPU)

VDD=+5V±10%,VSS=0V,Ta=25°C

Item	Symbol	Conditions	Min.	Max.	Unit
Address hold time	t _{AH8}	-	10	-	ns
Address setup time	t _{AW8}	-	20	-	ns
System cycle time	t _{CYC8}	-	1000	-	ns
Control pulse width	t _{CC}	-	200	-	ns
Data setup time	t _{DS8}	-	80	-	ns
Data hold time	t _{DH8}	-	10	-	ns
RD access time	t _{ACC8}	CL=100 PF	-	90	ns
Output disable time	t _{CH8}		10	60	ns

•MPU Bus Read/Write II (68-family MPU)

VDD=+5V±10% ,VSS=0V,Ta=25°C

Item	Symbol	Conditions	Min.	Max.	Unit
System cycle time	t _{CYC6}	-	1000	-	ns
Address setup time	t _{AW6}	-	20	-	ns
Address hold time	t _{AH6}	-	10	-	ns
Data hold time	t _{DS6}	-	80	-	ns
Data hold time	t _{DH6}	-	10	-	ns
Output disable time	t _{OH6}	CL=100 PF	10	60	ns
Access time	t _{ACC6}		-	90	ns
Enable pulse width	Read	-	100	-	ns
	Write		t _{EW}	80	-



2.4 Display Command

COMMAND

Summary

Command	Code											Function
	A0	RD E	R/W	D7	D6	D5	D4	D3	D2	D1	D0	
Display On/Off	0	1	0	1	0	1	0	1	1	1	0/1	Turns display on or off. 1: ON, 0:OFF
Display start line	0	1	0	1	1	0	Display start address(o to 31)					Specifies RAM line corresponding to top line of display.
Set page address	0	1	0	1	0	1	1	1	0	Page(o to 3)		Set s display RAM page in page address register.
Set column (segment) address	0	1	0	0	Column address (o to 79)							Sets display RAM column address in column address register.
Read status	0	0	1	Busy	ADC	ON/OFF	Reset	0	0	0	0	Reads the following status: BUSY 1: Busy 0: Ready ADC 1: CW output 0: CCW output ON/OFF 1: Display off 0: Display on RESET 1: Being reset 0: Normal
Write display data	1	1	0	Write data								Write data from data bus into display RAM.
Read display data	1	0	1	Read data								Reads data from display RAM onto data bus.
Select ADC	0	1	0	1	0	1	0	0	0	0	0/1	0: CW output, 1:CCW output
Statis drive ON/OFF	0	1	0	1	0	1	0	0	1	0	0/1	Selects static driving operation. 1:static drive, 0: Normal driving
Select duty	0	1	0	1	0	1	0	1	0	0	0/1	Selects LCD duty cycle 1: 1/32, 0: 1/16
Read-Modify-Write	0	1	0	1	1	1	0	0	0	0	0	Read-modify-write ON
End	0	1	0	1	1	1	0	1	1	1	0	Read-modify-write OFF
Reset	0	1	0	1	1	1	0	0	0	1	0	Software reset

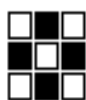

POWERTIP TECHNOLOGY CORPORATION

DISPLAY DEVICES FOR BETTER ELECTRONIC DESIGN

Command description

Table 1 is the command table. The SED1520 series identifies a data bus using a combination of A0 and R/ \overline{W} (RD or \overline{WR}) signals. As the MPU translates a command in the internal timing only (independent from the external clock). Its speed is very high. The busy check is usually not required.

Display ON/OFF

A0	$\frac{E}{RD}$	$\frac{R/\overline{W}}{\overline{WR}}$	D7	D6	D5	D4	D3	D2	D1	D0	
0	1	0	1	0	1	0	1	1	1	D	AEH,AFH

This command turns the display on and off.

- D=1: Display ON
- D=0: Display OFF

Display Start Line

This command specifies the line address shown in Figure 1 and indicates the display line that corresponds to COM0. The display area begins at the specified line address and continues in the line address increment direction. This area having the number of lines of the specified display duty is displayed. If the line address is changed dynamically by this command the vertical smooth scrolling and paging can be used.

A0	$\frac{E}{RD}$	$\frac{R/\overline{W}}{\overline{WR}}$	D7	D6	D5	D4	D3	D2	D1	D0	
0	1	0	1	1	0	A4	A3	A2	A1	A0	COH,DFH

This command loads the display start line register.

A4	A3	A2	A1	A0	Line Address
0	0	0	0	0	0
0	0	0	0	1	1
		⋮			⋮
		⋮			⋮
1	1	1	1	1	31

See Figure 2.

Set Page Address

This command specifies the page address that corresponds to the low address of the display data RAM when it is accessed by the MPU. Any bit of the display data RAM can be accessed when its page address and column address are specified. The display status is not changed even when the page address is changed.

A0	$\frac{E}{RD}$	$\frac{R/\overline{W}}{\overline{WR}}$	D7	D6	D5	D4	D3	D2	D1	D0	
0	1	0	1	0	1	1	1	0	A1	A0	B8H,BBH



POWERTIP TECHNOLOGY CORPORATION

DISPLAY DEVICES FOR BETTER ELECTRONIC DESIGN

This command loads the page address register.

A1	A0	Page
0	0	0
0	1	1
1	0	2
1	1	3

Set column Address

This command specifies a column address of the display data RAM. When the display data RAM is accessed by the MPU continuously, the column address is incremented by 1 each time it is accessed from the set address. Therefore, the MPU can access to data continuously. The column address stops to be incremented at address 80, and the page address is not changed continuously.

A0	\overline{E} RD	R/ \overline{W} \overline{WR}	D7	D6	D5	D4	D3	D2	D1	D0	
0	1	0	0	A6	A5	A4	A3	A2	A1	A0	00H,4FH

This command loads the column address register.

A6	A5	A4	A3	A2	A1	A0	Line Address
0	0	0	0	0	0	0	0
0	0	0	0	0	0	1	1
			⋮				⋮
			⋮				⋮
1	0	0	1	1	1	1	79

Read Status

A0	\overline{E} RD	R/ \overline{W} \overline{WR}	D7	D6	D5	D4	D3	D2	D1	D0
0	0	1	BUSY	ADC	ON/OFF	RESET	0	0	0	0

Reading the command I/O register (A0=0) yields system status information.

- The busy bit indicates whether the driver will accept a command or not.
 Busy=1: The driver is currently executing a command or is resetting. No new command will be accepted.
 Busy=0: The driver will accept a new command.
- The ACD bit indicates the way column addresses are assigned to segment drivers.
 ADC=1: Normal. Column address n → segment driver n.
 ADC=0: Inverted. Column address 79-u → segment driver u.
- The ON/OFF bit indicates the current status of the display.
 It is the inverse of the polarity of the display ON/OFF command.
 ON/OFF=1: Display OFF



POWERTIP TECHNOLOGY CORPORATION

DISPLAY DEVICES FOR BETTER ELECTRONIC DESIGN

ON/OFF=0: Display ON

- The RESET bit indicates whether the driver is executing a hardware or software reset or if it is in normal operating mode.

RESET=1: Currently executing reset command.

RESET=0: Normal operation

Write Display Data

A0	$\overline{\text{RD}}$	$\overline{\text{WR}}$	D7	D6	D5	D4	D3	D2	D1	D0
1	1	0	Write data							

Writes 8-bit of data into the display data RAM, at a location specified by the contents of the column address and page address registers and then increments the column address register by one.

Read Display Data

A0	$\overline{\text{RD}}$	$\overline{\text{WR}}$	D7	D6	D5	D4	D3	D2	D1	D0
1	0	1	Read data							

Reads 8-bits of data from the data I/O latch, updates the contents of the I/O latch with display data from the display data RAM location specified by the contents of the column address and page address registers and then

increments the column address register.

After loading a new address into the column address register one dummy read is required before valid data is obtained.

Select ADC

A0	$\overline{\text{RD}}$	$\overline{\text{WR}}$	D7	D6	D5	D4	D3	D2	D1	D0
0	1	0	1	0	1	0	0	0	0	D

A0H, A1H

This command selects the relationship between display data RAM column addresses and segment drivers.

D=1: SEG0 ← column address 4FH,...(inverted)

D=0: SEG0 ← column address 00H,...(normal)

This command is provided to reduce restrictions on the placement of driver ICs and routing of traces during printed circuit board design. See Figure 1 for a table of segments and column addresses for the two values of D.



POWERTIP TECHNOLOGY CORPORATION

DISPLAY DEVICES FOR BETTER ELECTRONIC DESIGN

Static Drive ON/OFF

A0	$\frac{E}{RD}$	$\frac{R/\overline{W}}{WR}$	D7	D6	D5	D4	D3	D2	D1	D0	
0	1	0	1	0	1	0	0	1	0	D	A4H, ,A5H

Forces display on and all common outputs to be selected.

D=1: Static drive on

D=0: Static drive off

Select Duty

A0	$\frac{E}{RD}$	$\frac{R/\overline{W}}{WR}$	D7	D6	D5	D4	D3	D2	D1	D0	
0	1	0	1	0	1	0	1	0	0	D	A8H, ,A9H

This command sets the duty cycle of the LCD drive .

SED1520

D=1: 1/32 duty cycle

D=0: 1/16 duty cycle

		SED1521FOA
SED1520FOA	1/32	1/32
	1/16	1/16
SED1522FOA	1/16	1/32
	1/8	1/16

Read-Modify-Write

A0	$\frac{E}{RD}$	$\frac{R/\overline{W}}{WR}$	D7	D6	D5	D4	D3	D2	D1	D0	
0	1	0	1	1	1	0	0	0	0	0	EOH

This command defeats column address register auto-increment after data reads. The current contents of the column address register are saved. This mode remains active until an End command is received.

- Operation sequence during cursor display

When the End command is entered, the column address is returned to the one used during input of Read-Modify-Write command. This function can reduce the load of MPU when data change is repeated at a specific display area (such as cursor blinking).

* Any command other than Data Read or Write can be used in the Read-Modify-Write mode. However, the Column Address Set command cannot be used.



POWERTIP TECHNOLOGY CORPORATION

DISPLAY DEVICES FOR BETTER ELECTRONIC DESIGN

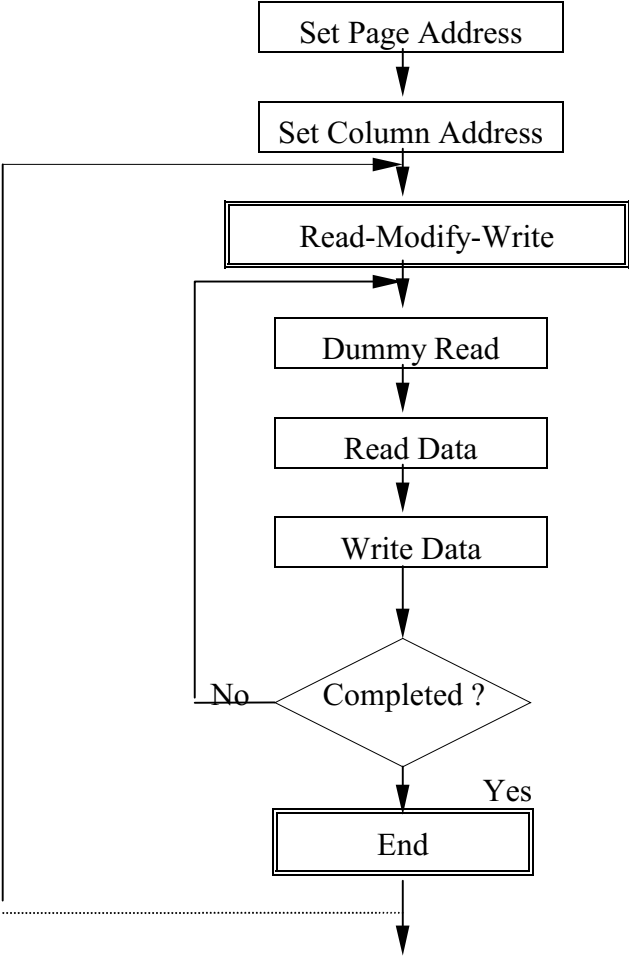

End

A0	\overline{E} RD	$\overline{R/W}$ WR	D7	D6	D5	D4	D3	D2	D1	D0	
0	1	0	1	1	1	0	1	1	1	0	EEH

This command cancels read-modify-write mode and restores the contents of the column address register to their value prior to the receipt of the Read-Modify-Write command.

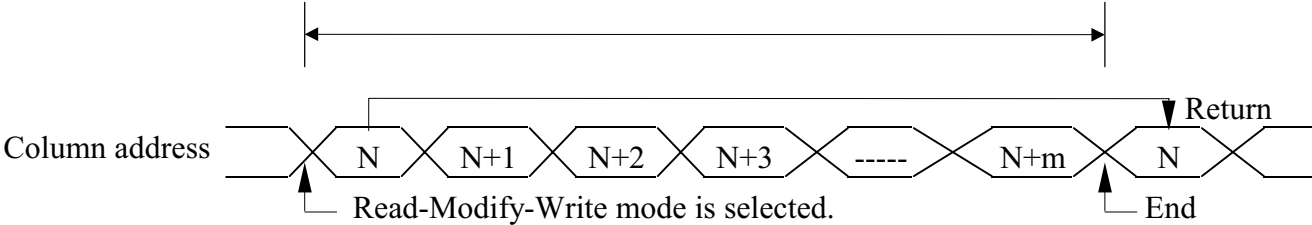

Reset

A0	$\overline{\text{RD}}$	$\overline{\text{R/W}}$	D7	D6	D5	D4	D3	D2	D1	D0
0	1	0	1	1	1	0	0	0	1	0

E2H

This command clears

- the display start line register.
- and set page address register to 3 page.

It does not affect the contents of the display data RAM.

When the power supply is turned on, a Reset signal is entered in the RES pin. The Reset command cannot be used instead of this Reset signal.





POWERTIP TECHNOLOGY CORPORATION
DISPLAY DEVICES FOR BETTER ELECTRONIC DESIGN