

3.3-V CAN TRANSCEIVER

FEATURES

- Bus-Pin Fault Protection Exceeds ± 36 V
- Bus-Pin ESD Protection Exceeds 16-kV HBM
- Compatible With ISO 11898
- Signaling Rates⁽¹⁾ up to 1 Mbps
- Extended -7 -V to 12-V Common-Mode Range
- High-Input Impedance Allows for 120 Nodes
- LVTTTL I/Os Are 5-V Tolerant
- Adjustable Driver Transition Times for Improved Signal Quality
- Unpowered Node Does Not Disturb the Bus
- Low-Current Standby Mode . . . 200- μ A Typical
- Thermal Shutdown Protection
- Power-Up/Down Glitch-Free Bus Inputs and Outputs
 - High Input Impedance With Low V_{CC}
 - Monolithic Output During Power Cycling
- Loopback for Diagnostic Functions Available
- DeviceNet Vendor ID #806

⁽¹⁾ The signaling rate of a line is the number of voltage transitions that are made per second expressed in the units bps (bits per second).

SUPPORTS DEFENSE, AEROSPACE, AND MEDICAL APPLICATIONS

- Controlled Baseline
- One Assembly/Test Site
- One Fabrication Site
- Available in Military ($-55^{\circ}\text{C}/125^{\circ}\text{C}$) Temperature Range⁽¹⁾
- Extended Product Life Cycle
- Extended Product-Change Notification
- Product Traceability

⁽¹⁾ Additional temperature ranges available - contact factory

APPLICATIONS

- CAN Data Bus
 - DeviceNet™ Data Buses
 - Smart Distributed Systems (SDS™)
- SAE J1939 Standard Data Bus Interface
- NMEA 2000 Standard Data Bus Interface
- ISO 11783 Standard Data Bus Interface

DESCRIPTION

The SN65HVD233 is used in applications employing the controller area network (CAN) serial communication physical layer in accordance with the ISO 11898 standard. As a CAN transceiver, it provides transmit and receive capability between the differential CAN bus and a CAN controller, with signaling rates up to 1 Mbps.

Designed for operation in especially harsh environments, the device features cross-wire, overvoltage and loss of ground protection to ± 36 V, with overtemperature protection and common-mode transient protection of ± 100 V. This device operates over a -7 -V to 12-V common-mode range with a maximum of 60 nodes on a bus.

FUNCTIONAL BLOCK DIAGRAM

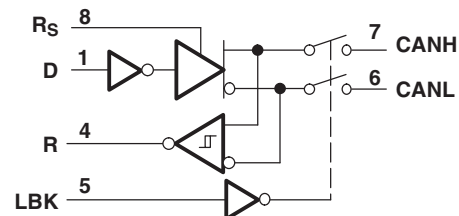

Please be aware that an important notice concerning availability, standard warranty, and use in critical applications of Texas Instruments semiconductor products and disclaimers thereto appears at the end of this data sheet.

DeviceNet is a trademark of Open DeviceNet Vendor Association.



This device has limited built-in ESD protection. The leads should be shorted together or the device placed in conductive foam during storage or handling to prevent electrostatic damage to the MOS gates.

DESCRIPTION (CONTINUED)

If the common-mode range is restricted to the ISO-11898 Standard range of -2 V to 7 V , up to 120 nodes may be connected on a bus. This transceiver interfaces the single-ended CAN controller with the differential CAN bus found in industrial, building automation, and automotive applications.

The R_S (pin 8) of the SN65HVD233 provides for three modes of operation: high-speed, slope control, or low-power standby mode. The high-speed mode of operation is selected by connecting R_S directly to ground, allowing the driver output transistors to switch on and off as fast as possible with no limitation on the rise and fall slope. The rise and fall slope can be adjusted by connecting a resistor to ground at R_S , since the slope is proportional to the pin's output current. Slope control is implemented with a resistor value of $10\text{ k}\Omega$ to achieve a slew rate of $\approx 15\text{ V}/\mu\text{s}$ and a value of $100\text{ k}\Omega$ to achieve $\approx 2.0\text{ V}/\mu\text{s}$ slew rate. For more information about slope control, refer to the application information section.

The SN65HVD233 enters a low-current standby mode during which the driver is switched off and the receiver remains active if a high logic level is applied to R_S . The local protocol controller reverses this low-current standby mode when it needs to transmit to the bus.

A logic high on the loopback LBK (pin 5) of the SN65HVD233 places the bus output and bus input in a high-impedance state. The remaining circuit remains active and available for driver to receiver loopback, self-diagnostic node functions without disturbing the bus.

AVAILABLE OPTIONS

PART NUMBER	LOW POWER MODE	SLOPE CONTROL	DIAGNOSTIC LOOPBACK	AUTOBAUD LOOPBACK
SN65HVD233	200- μA standby mode	Adjustable	Yes	No

ORDERING INFORMATION⁽¹⁾

T_A	PACKAGE ⁽²⁾		ORDERABLE PART NUMBER	TOP-SIDE MARKING
-55°C to 125°C	SOIC – D	Reel of 2500	SN65HVD233MDREP	H233EP

- (1) For the most current package and ordering information, see the Package Option Addendum at the end of this document, or see the TI Web site at www.ti.com.
- (2) Package drawings, standard packing quantities, thermal data, symbolization, and PCB design guidelines are available at www.ti.com/sc/package.

POWER DISSIPATION RATINGS

PACKAGE	CIRCUIT BOARD	T _A ≤ 25°C POWER RATING	DERATING FACTOR ⁽¹⁾ ABOVE T _A = 25°C	T _A = 85°C POWER RATING	T _A = 125°C POWER RATING
D	Low-K	596.6 mW	5.7 mW/°C	255.7 mW	28.4 mW
D	High-K	1076.9 mW	10.3 mW/°C	461.5 mW	51.3 mW

(1) This is the inverse of the junction-to-ambient thermal resistance when board-mounted and with no air flow.

ABSOLUTE MAXIMUM RATINGS^{(1) (2)}

over operating free-air temperature range (unless otherwise noted)

		VALUE	UNIT
V _{CC}	Supply voltage range	–0.3 to 7	V
	Voltage range at any bus terminal (CANH or CANL)	–36 to 36	V
	Voltage input range, transient pulse, CANH and CANL, through 100 Ω (see Figure 7)	–100 to 100	V
V _I	Input voltage range, (D, R, R _S , LBK)	–0.5 to 7	V
I _O	Receiver output current	–10 to 10	mA
	Electrostatic discharge	Human Body Model ⁽³⁾	CANH, CANL and GND
		Human Body Model ⁽³⁾	All pins
		Charged-Device Mode ⁽⁴⁾	All pins
	Continuous total power dissipation	See Dissipation Rating Table	
T _J	Operating junction temperature	150	°C

(1) Stresses beyond those listed under *absolute maximum ratings* may cause permanent damage to the device. These are stress ratings only, and functional operation of the device at these or any other conditions beyond those indicated under *recommended operating conditions* is not implied. Exposure to absolute-maximum-rated conditions for extended periods may affect device reliability.

(2) All voltage values, except differential I/O bus voltages, are with respect to network ground terminal.

(3) Tested in accordance with JEDEC Standard 22, Test Method A114-A.

(4) Tested in accordance with JEDEC Standard 22, Test Method C101.

RECOMMENDED OPERATING CONDITIONS

		MIN	TYP	MAX	UNIT
V _{CC}	Supply voltage	3		3.6	
	Voltage at any bus terminal (separately or common mode)	–7		12	
V _{IH}	High-level input voltage		D, LBK	5.5	V
V _{IL}	Low-level input voltage		D, LBK	0.8	
V _{ID}	Differential input voltage	–6		6	
	Resistance from R _S to ground	0		100	kΩ
V _{I(RS)}	Input Voltage at R _S for standby	0.75 V _{CC}		5.5	V
I _{OH}	High-level output current	–50			mA
		–10			
I _{OL}	Low-level output current			50	mA
				10	
T _J	Operating junction temperature			150	°C
T _A	Operating free-air temperature ⁽¹⁾	–55		125	°C

(1) Maximum free-air temperature operation is allowed as long as the device maximum junction temperature is not exceeded.

DRIVER ELECTRICAL CHARACTERISTICS

over operating free-air temperature range (unless otherwise noted)

PARAMETER		TEST CONDITIONS	MIN	TYP ⁽¹⁾	MAX	UNIT	
V _{O(D)}	Bus output voltage (Dominant)	CANH	D = 0 V, R _S = 0 V, See Figure 1 and Figure 2	2.45	V _{CC}	V	
		CANL		0.5	1.25		
V _O	Bus output voltage (Recessive)	CANH	D = 3 V, R _S = 0 V, See Figure 1 and Figure 2	2.3		V	
		CANL		2.3			
V _{OD(D)}	Differential output voltage (Dominant)	D = 0 V, R _S = 0 V, See Figure 1 and Figure 2	1.5	2	3	V	
		D = 0 V, R _S = 0 V, See Figure 2 and Figure 3	1.2	2	3		
V _{OD}	Differential output voltage (Recessive)	D = 3 V, R _S = 0 V, See Figure 1 and Figure 2	-120	12		mV	
		D = 3 V, R _S = 0 V, No load	-0.5	0.05		V	
V _{OC(pp)}	Peak-to-peak common-mode output voltage	See Figure 9	1		V		
I _{IH}	High-level input current	D, LBK	D = 2 V		-30	30	μA
I _{IL}	Low-level input current	D, LBK	D = 0.8 V		-30	30	μA
I _{OS}	Short-circuit output current	V _{CANH} = -7 V, CANL Open, See Figure 12		-250		mA	
		V _{CANH} = 12 V, CANL Open, See Figure 12		1			
		V _{CANL} = -7 V, CANH Open, See Figure 12		-1			
		V _{CANL} = 12 V, CANH Open, See Figure 12		250			
C _O	Output capacitance	See receiver input capacitance					
I _{IRs(s)}	R _S input current for standby	R _S = 0.75 V _{CC}		-10		μA	
I _{CC}	Supply current	Standby	R _S = V _{CC} , D = V _{CC} , LBK = 0 V		200	600	μA
		Dominant	D = 0 V, No load, LBK = 0 V, R _S = 0 V		6		mA
		Recessive	D = V _{CC} , No load, LBK = 0 V, R _S = 0 V		6		

(1) All typical values are at 25°C and with a 3.3 V supply.

DRIVER SWITCHING CHARACTERISTICS

over operating free-air temperature range (unless otherwise noted)

PARAMETER		TEST CONDITIONS	MIN	TYP ⁽¹⁾	MAX	UNIT
t_{PLH}	Propagation delay time, low-to-high-level output	$R_S = 0\text{ V}$, See Figure 4		35	95	ns
		R_S with 10 k Ω to ground, See Figure 4		70	125	
		R_S with 100 k Ω to ground, See Figure 4		500	870	
t_{PHL}	Propagation delay time, high-to-low-level output	$R_S = 0\text{ V}$, See Figure 4		70	120	ns
		R_S with 10 k Ω to ground, See Figure 4		130	180	
		R_S with 100 k Ω to ground, See Figure 4		870	1200	
$t_{sk(p)}$	Pulse skew ($t_{PHL} - t_{PLH}$)	$R_S = 0\text{ V}$, See Figure 4		35		ns
		R_S with 10 k Ω to ground, See Figure 4		60		
		R_S with 100 k Ω to ground, See Figure 4		370		
t_r	Differential output signal rise time	$R_S = 0\text{ V}$, See Figure 4	20		70	ns
t_f	Differential output signal fall time		20		70	
t_r	Differential output signal rise time	R_S with 10 k Ω to ground, See Figure 4	30		135	ns
t_f	Differential output signal fall time		30		135	
t_r	Differential output signal rise time	R_S with 100 k Ω to ground, See Figure 4	300		1400	ns
t_f	Differential output signal fall time		300		1400	
$t_{en(s)}$	Enable time from standby to dominant	See Figure 8		0.6	1.5	μs

(1) All typical values are at 25°C and with a 3.3 V supply. Timing parameters are characterized but not production tested.

RECEIVER ELECTRICAL CHARACTERISTICS

over operating free-air temperature range (unless otherwise noted)

PARAMETER		TEST CONDITIONS	MIN	TYP ⁽¹⁾	MAX	UNIT		
V_{IT+}	Positive-going input threshold voltage ⁽²⁾	LBK = 0 V, See Table 1		750	900	mV		
V_{IT-}	Negative-going input threshold voltage ⁽²⁾		500	650				
V_{hys}	Hysteresis voltage ($V_{IT+} - V_{IT-}$)		100					
V_{OH}	High-level output voltage	$I_O = -4$ mA, See Figure 6	2.4			V		
V_{OL}	Low-level output voltage	$I_O = 4$ mA, See Figure 6		0.4				
I_i	Bus input current	CANH or CANL = 12 V	Other bus pin = 0 V, D = 3 V, LBK = 0 V, $R_S = 0$ V	150	500	μ A		
		CANH or CANL = 12 V, $V_{CC} = 0$ V		200	600			
		CANH or CANL = -7 V		-610	-150			
		CANH or CANL = -7 V, $V_{CC} = 0$ V		-450	-130			
C_i	Input capacitance (CANH or CANL)	Pin-to-ground, $V_i = 0.4 \sin(4E6\pi t) + 0.5V$, D = 3 V, LBK = 0 V		40		pF		
C_{iD}	Differential input capacitance	Pin-to-pin, $V_i = 0.4 \sin(4E6\pi t) + 0.5V$, D = 3 V, LBK = 0 V		20				
R_{iD}	Differential input resistance	D = 3 V, LBK = 0 V	40		100	k Ω		
R_{iN}	Input resistance (CANH or CANL)		20		50			
I_{CC}	Supply current	Sleep	D = V_{CC} , $R_S = 0$ V or V_{CC}		0.05	2	μ A	
		Standby	$R_S = V_{CC}$, D = V_{CC} , LBK = 0 V		200	600		
		Dominant	D = 0 V, No load, $R_S = 0$ V, LBK = 0 V				6	mA
		Recessive	D = V_{CC} , No load, $R_S = 0$ V, LBK = 0 V				6	

(1) All typical values are at 25°C and with a 3.3 V supply.

(2) Characterized but not production tested.

RECEIVER SWITCHING CHARACTERISTICS

over operating free-air temperature range (unless otherwise noted)

PARAMETER		TEST CONDITIONS	MIN	TYP ⁽¹⁾	MAX	UNIT
t_{PLH}	Propagation delay time, low-to-high-level output	See Figure 6		35	60	ns
t_{PHL}	Propagation delay time, high-to-low-level output			35	60	
$t_{sk(p)}$	Pulse skew ($ t_{PHL} - t_{PLH} $)			7		
t_r	Output signal rise time			2	6.5	
t_f	Output signal fall time			2	6.5	

(1) All typical values are at 25°C and with a 3.3 V supply. Timing parameters are characterized but not production tested.

DEVICE SWITCHING CHARACTERISTICS

over operating free-air temperature range (unless otherwise noted)

PARAMETER		TEST CONDITIONS	MIN	TYP ⁽¹⁾	MAX	UNIT
$t_{(LBK)}$	Loopback delay, driver input to receiver output	HVD233 See Figure 11		7.5	13	ns
$t_{(loop1)}$	Total loop delay, driver input to receiver output, recessive to dominant	$R_S = 0\text{ V}$, See Figure 10		70	135	ns
		R_S with 10 k Ω to ground, See Figure 10		105	190	
		R_S with 100 k Ω to ground, See Figure 10		535	1000	
$t_{(loop2)}$	Total loop delay, driver input to receiver output, dominant to recessive	$R_S = 0\text{ V}$, See Figure 10		70	135	ns
		R_S with 10 k Ω to ground, See Figure 10		105	190	
		R_S with 100 k Ω to ground, See Figure 10		535	1100	

(1) All typical values are at 25°C and with a 3.3 V supply. Timing parameters are characterized but not production tested.

PARAMETER MEASUREMENT INFORMATION

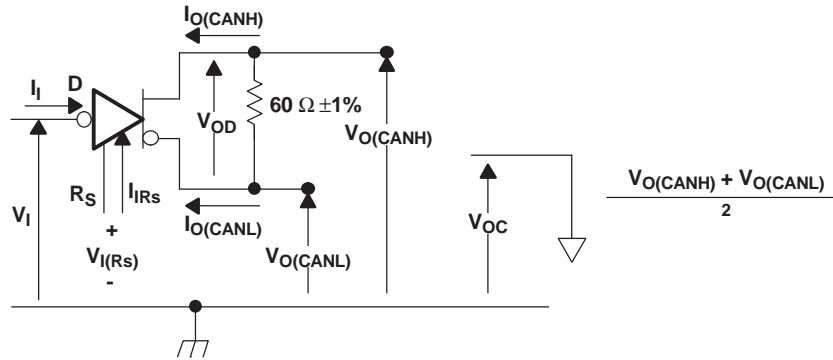

Figure 1. Driver Voltage, Current, and Test Definition

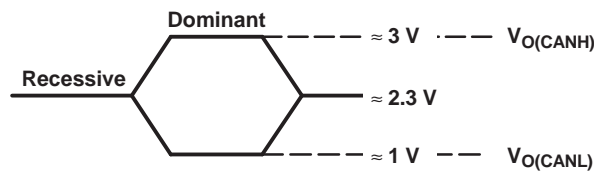

Figure 2. Bus Logic State Voltage Definitions

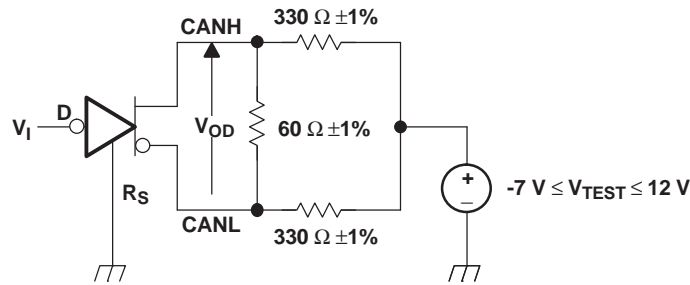
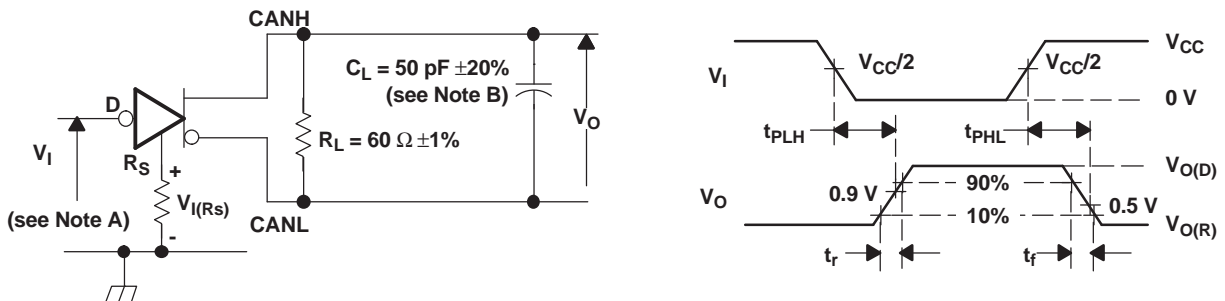

Figure 3. Driver VOD



- A. The input pulse is supplied by a generator having the following characteristics: Pulse repetition rate (PRR) ≤ 125 kHz, 50% duty cycle, $t_r \leq 6$ ns, $t_f \leq 6$ ns, $Z_0 = 50 \Omega$.
- B. C_L includes fixture and instrumentation capacitance.

Figure 4. Driver Test Circuit and Voltage Waveforms

PARAMETER MEASUREMENT INFORMATION (continued)

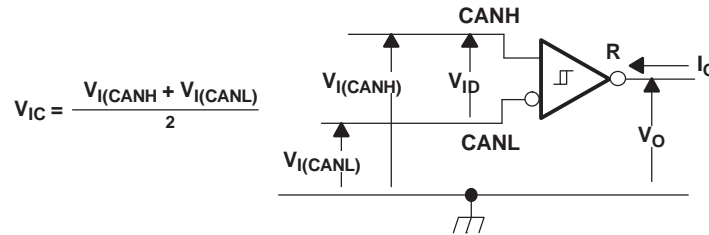
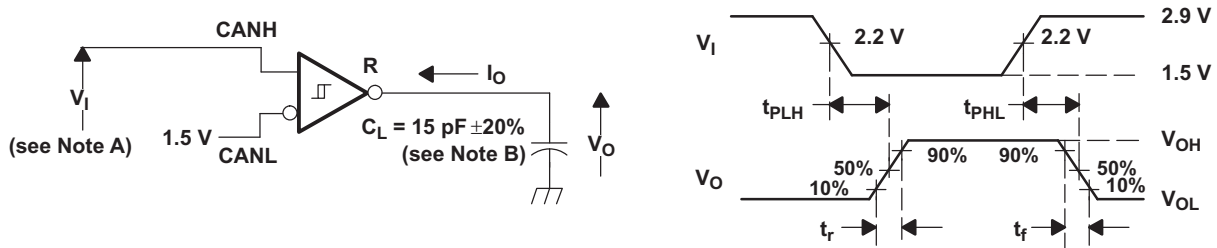

Figure 5. Receiver Voltage and Current Definitions



- A. The input pulse is supplied by a generator having the following characteristics: Pulse repetition rate (PRR) ≤ 125 kHz, 50% duty cycle, $t_r \leq 6$ ns, $t_f \leq 6$ ns, $Z_O = 50 \Omega$.
- B. C_L includes fixture and instrumentation capacitance.

Figure 6. Receiver Test Circuit and Voltage Waveforms

Table 1. Differential Input Voltage Threshold Test

INPUT		OUTPUT		MEASURED
V_{CANH}	V_{CANL}	R		$ V_{ID} $
-6.1 V	-7 V	L	V_{OL}	900 mV
12 V	11.1 V	L		900 mV
-1 V	-7 V	L		6 V
12 V	6 V	L		6 V
-6.5 V	-7 V	H	V_{OH}	500 mV
12 V	11.5 V	H		500 mV
-7 V	-1 V	H		6 V
6 V	12 V	H		6 V
Open	Open	H		X

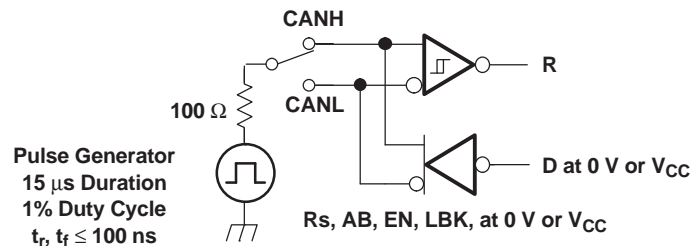

NOTE: This test is conducted to test survivability only. Data stability at the R output is not specified.

Figure 7. Test Circuit, Transient Over Voltage Test

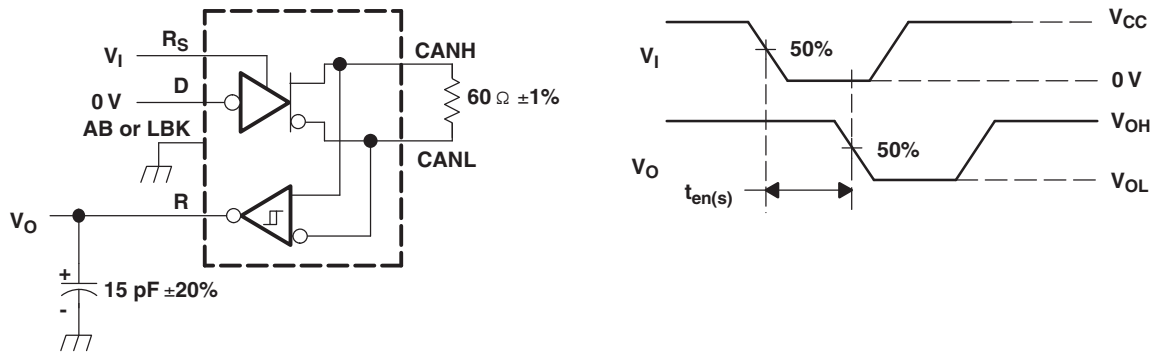

NOTE: All V_I input pulses are supplied by a generator having the following characteristics: t_r or $t_f \leq 6$ ns, pulse repetition rate (PRR) = 125 kHz, 50% duty cycle.

Figure 8. $t_{en(s)}$ Test Circuit and Voltage Waveforms

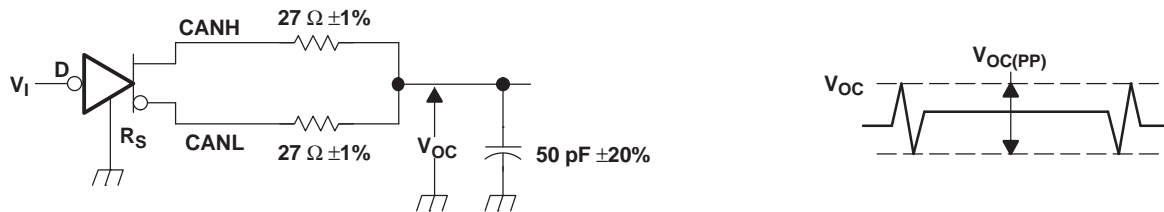

NOTE: All V_I input pulses are supplied by a generator having the following characteristics: t_r or $t_f \leq 6$ ns, pulse repetition rate (PRR) = 125 kHz, 50% duty cycle.

Figure 9. $V_{OC(pp)}$ Test Circuit and Voltage Waveforms

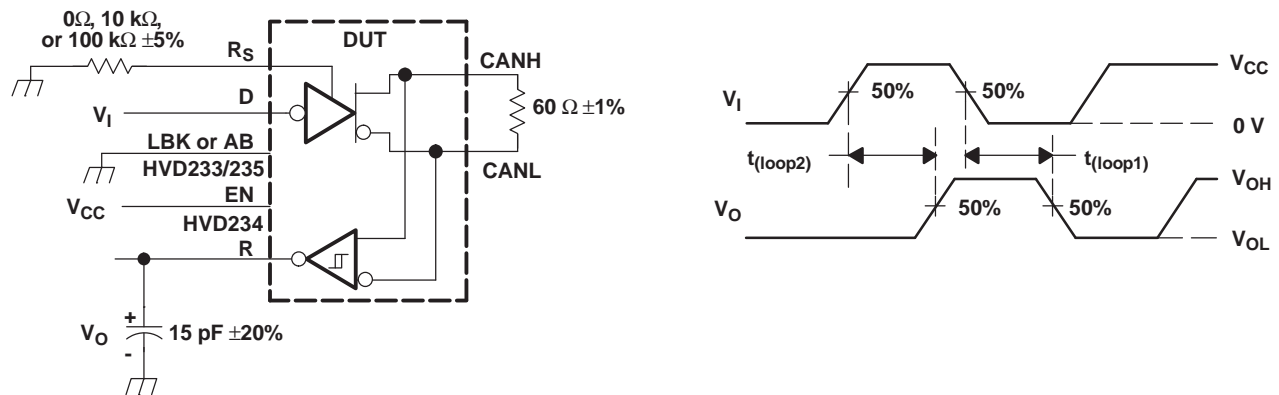

NOTE: All V_I input pulses are supplied by a generator having the following characteristics: t_r or $t_f \leq 6$ ns, pulse repetition rate (PRR) = 125 kHz, 50% duty cycle.

Figure 10. $t_{(loop)}$ Test Circuit and Voltage Waveforms

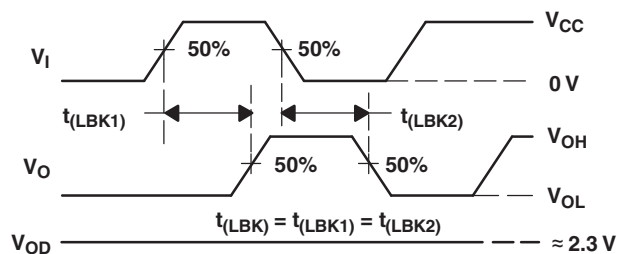
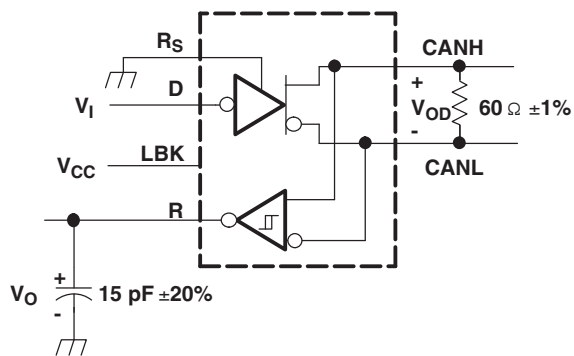

NOTE: All V_i input pulses are supplied by a generator having the following characteristics:
 t_r or $t_f \leq 6$ ns, pulse repetition rate (PRR) = 125 kHz, 50% duty cycle.

Figure 11. $t_{(LBK)}$ Test Circuit and Voltage Waveforms

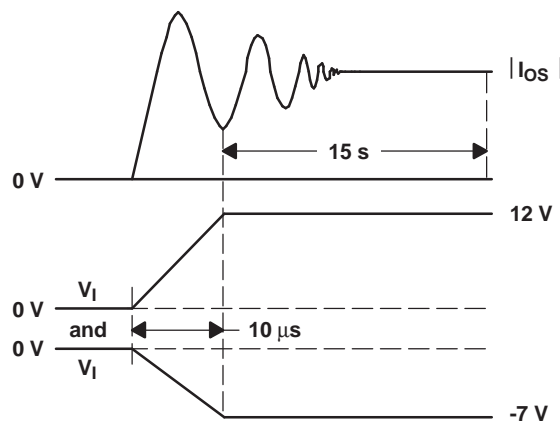
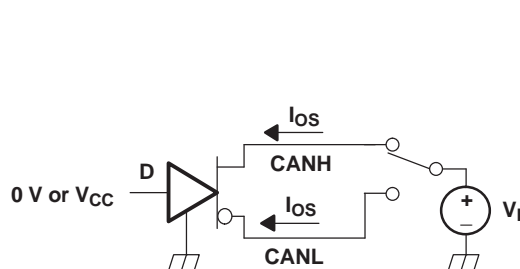
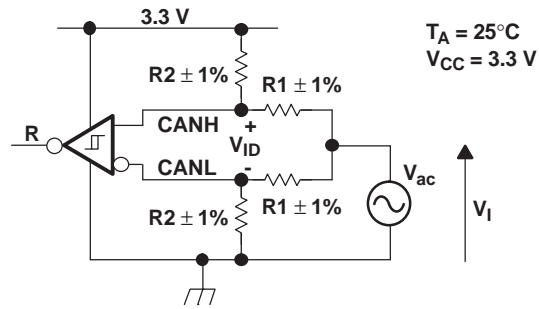
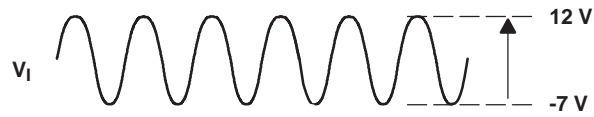

Figure 12. I_{OS} Test Circuit and Waveforms



The R Output State Does Not Change During Application of the Input Waveform.

V_{ID}	R1	R2
500 mV	50 Ω	280 Ω
900 mV	50 Ω	130 Ω



NOTE: All input pulses are supplied by a generator with $f \leq 1.5$ MHz.

Figure 13. Common-Mode Voltage Rejection

DEVICE INFORMATION

SN65HVD233D
(TOP VIEW)

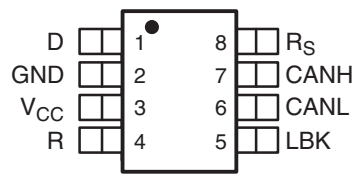

EQUIVALENT INPUT AND OUTPUT SCHEMATIC DIAGRAMS

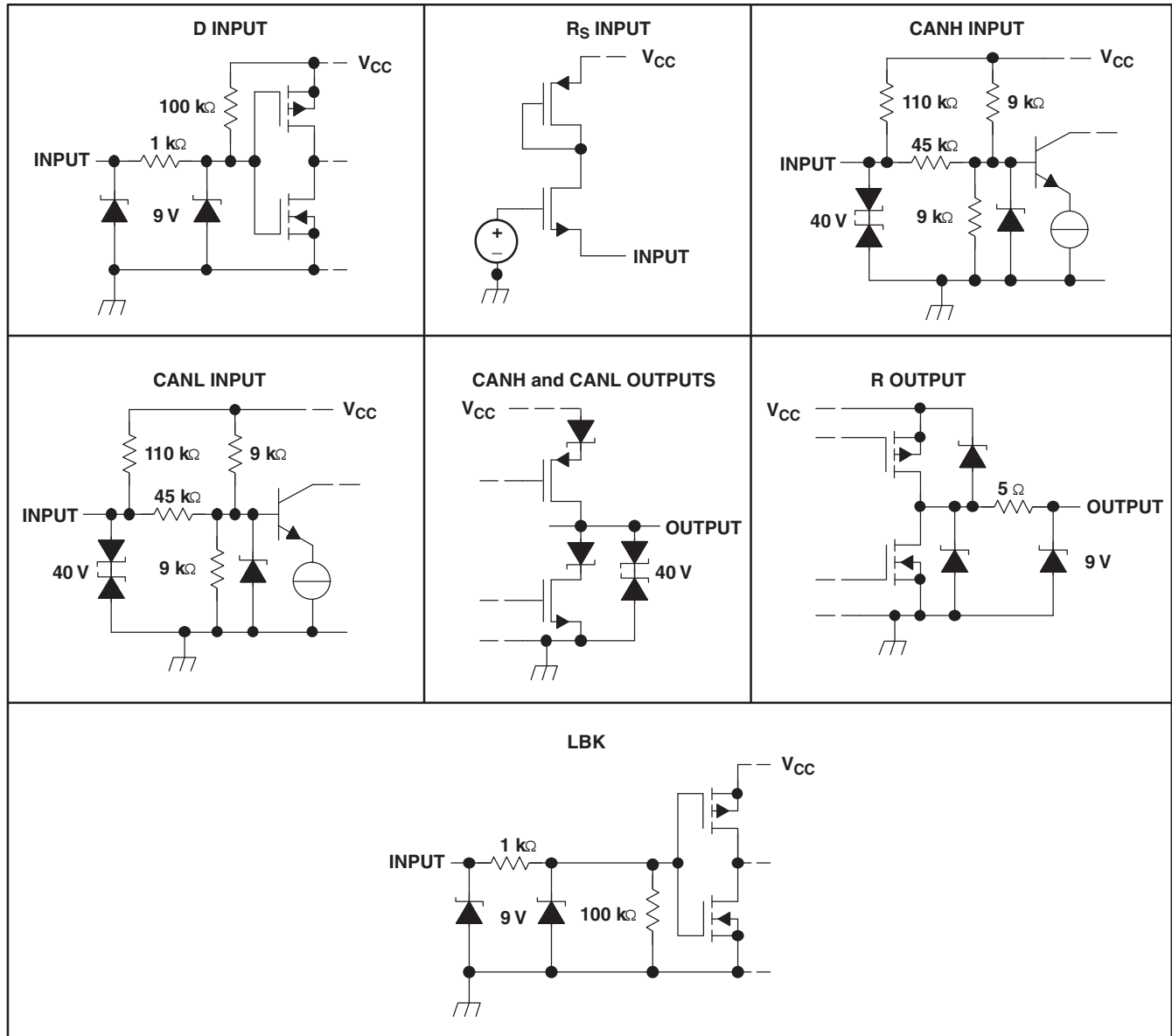

Table 2. Thermal Characteristics

PARAMETERS		TEST CONDITIONS	VALUE	UNIT
θ_{JA}	Junction-to-ambient thermal resistance ⁽¹⁾	Low-K ⁽²⁾ board, no air flow	185	°C/W
		High-K ⁽³⁾ board, no air flow	101	
θ_{JB}	Junction-to-board thermal resistance	High-K ⁽³⁾ board, no air flow	82.8	°C/W
θ_{JC}	Junction-to-case thermal resistance		26.5	°C/W
$P_{(AVG)}$	Average power dissipation	$R_L = 60 \Omega$, R_S at 0 V, input to D a 1-MHz 50% duty cycle square wave V_{CC} at 3.3 V, $T_A = 25^\circ\text{C}$	36.4	mW
$T_{(SD)}$	Thermal shutdown junction temperature		170	°C

- (1) See TI literature number [SZZA003](#) for an explanation of this parameter.
(2) JESD51-3 low effective thermal conductivity test board for leaded surface mount packages.
(3) JESD51-7 high effective thermal conductivity test board for leaded surface mount packages.

FUNCTION TABLES

DRIVER ⁽¹⁾					
INPUTS			OUTPUTS		
D	LBK/AB	R_s	CANH	CANL	BUS STATE
X	X	$> 0.75 V_{CC}$	Z	Z	Recessive
L	L or open	$\leq 0.33 V_{CC}$	H	L	Dominant
H or open	X		Z	Z	Recessive
X	H	$\leq 0.33 V_{CC}$	Z	Z	Recessive

- (1) H = high level; L = low level; Z = high impedance; X = irrelevant; ? = indeterminate

RECEIVER ⁽¹⁾				
INPUTS				OUTPUT
BUS STATE	$V_{ID} = V_{(CANH)} - V_{(CANL)}$	LBK	D	R
Dominant	$V_{ID} \geq 0.9 \text{ V}$	L or open	X	L
Recessive	$V_{ID} \leq 0.5 \text{ V}$ or open	L or open	H or open	H
?	$0.5 \text{ V} < V_{ID} < 0.9 \text{ V}$	L or open	H or open	?
X	X	H	L	L
X	X		H	H

- (1) H = high level; L = low level; Z = high impedance; X = irrelevant; ? = indeterminate

TYPICAL CHARACTERISTICS

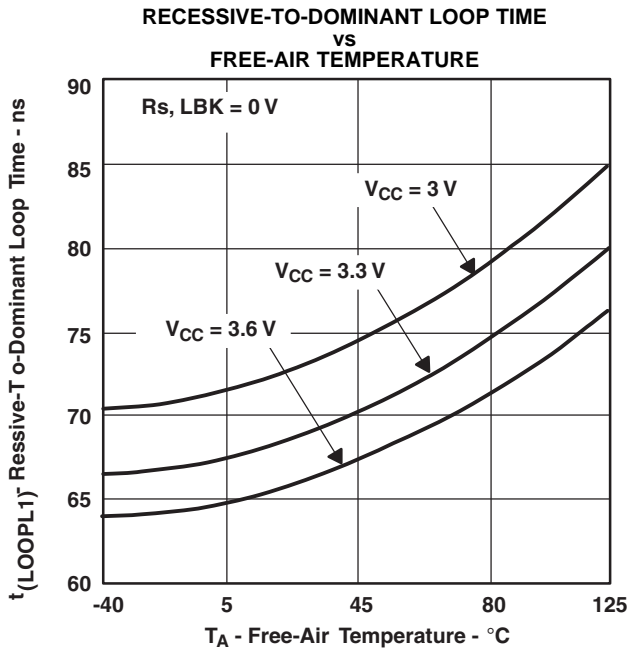

Figure 14.

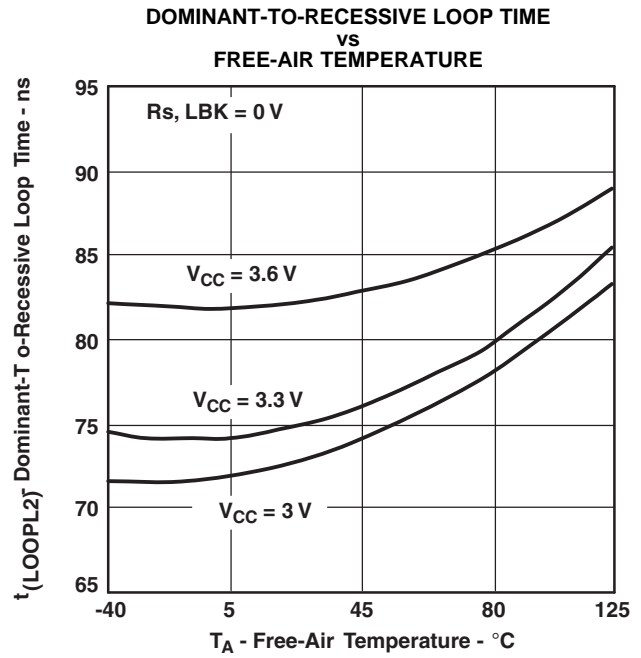

Figure 15.

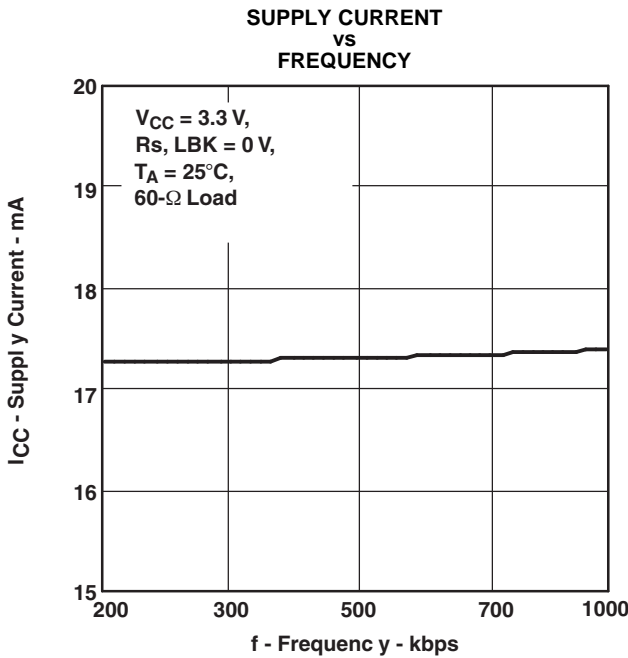

Figure 16.

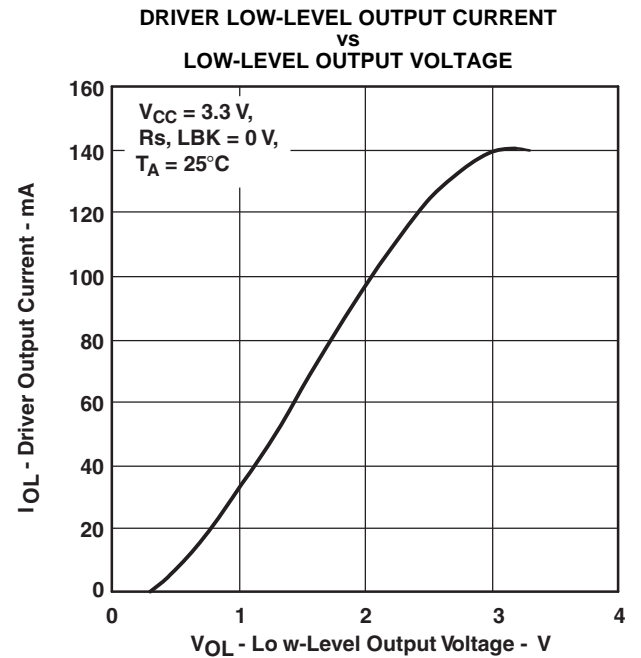

Figure 17.

TYPICAL CHARACTERISTICS (continued)

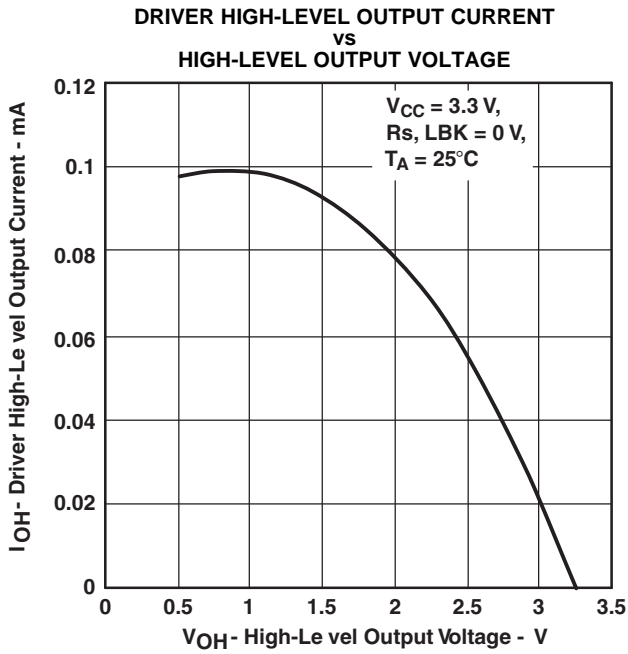

Figure 18.

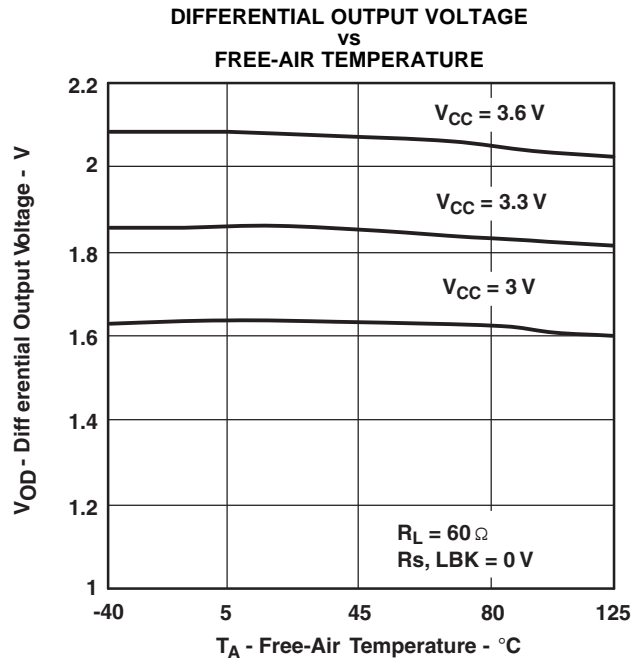

Figure 19.

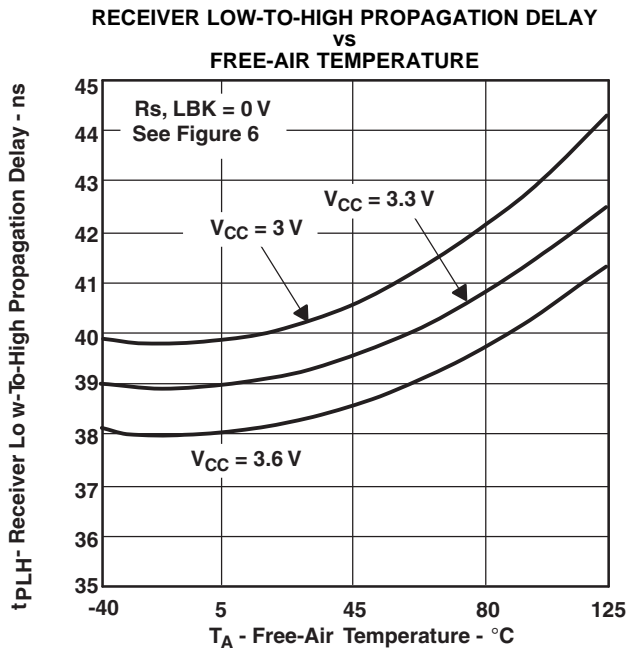

Figure 20.

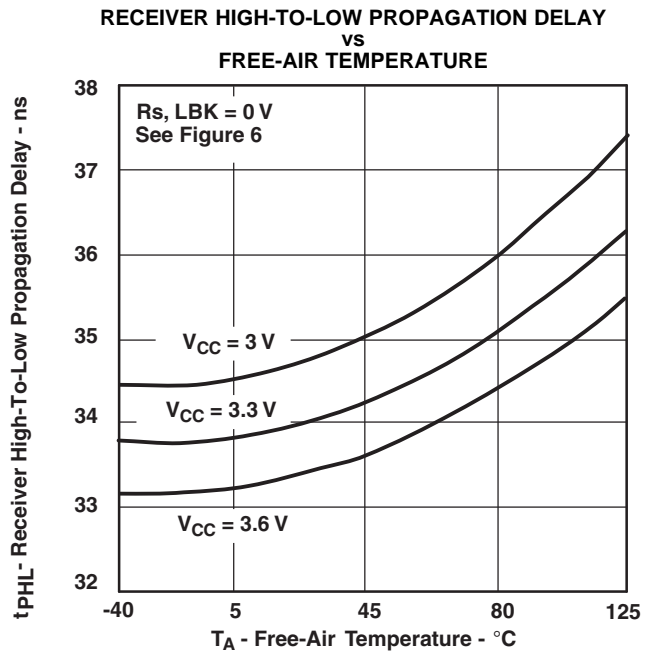

Figure 21.

TYPICAL CHARACTERISTICS (continued)

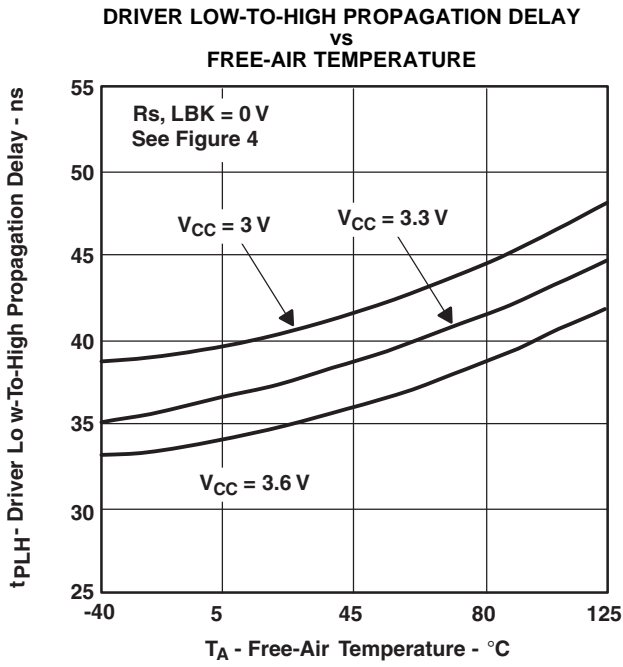

Figure 22.

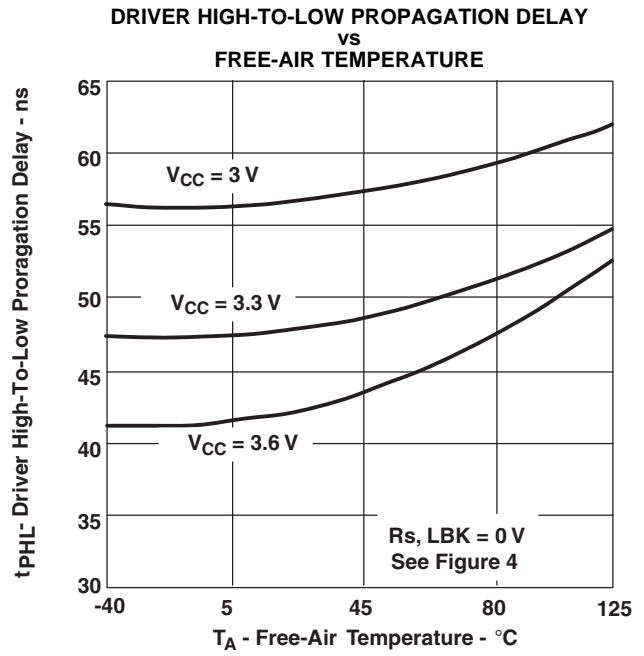

Figure 23.

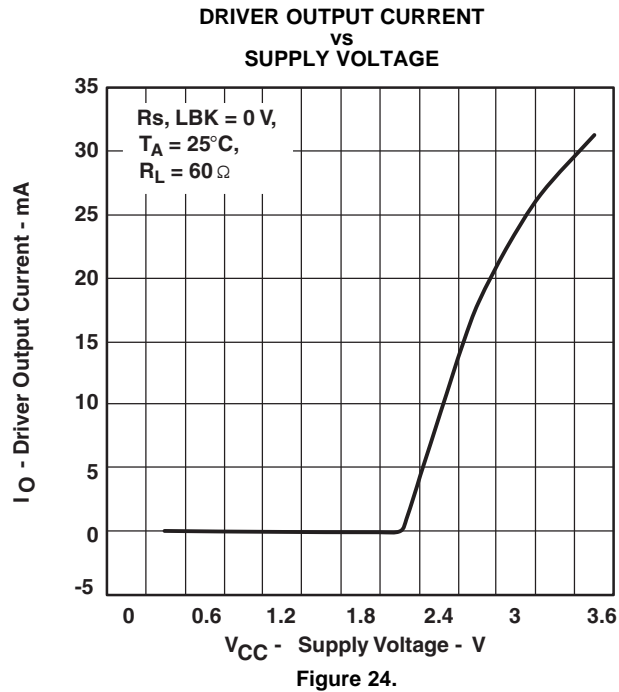

Figure 24.

APPLICATION INFORMATION

DIAGNOSTIC LOOPBACK (SN65HVD233)

The loopback function of the SN65HVD233 is enabled with a high-level input to LBK. This forces the driver into a recessive state and redirects the data (D) input at pin 1 to the received-data output (R) at pin 4. This allows the host controller to input and read back a bit sequence to perform diagnostic routines without disturbing the CAN bus. A typical CAN bus application is displayed in [Figure 25](#).

If the LBK pin is not used it may be tied to ground (GND). However, it is pulled low internally (defaults to a low-level input) and may be left open if not in use.

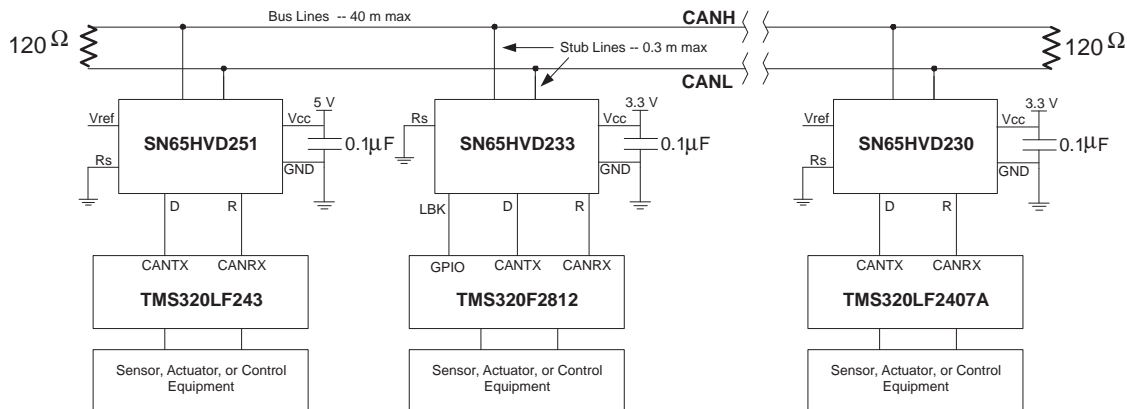

Figure 25. Typical HVD233 Application

ISO 11898 COMPLIANCE OF SN65HVD230 FAMILY OF 3.3-V CAN TRANSCEIVERS

Introduction

Many users value the low power consumption of operating their CAN transceivers from a 3.3 V supply. However, some are concerned about the interoperability with 5-V supplied transceivers on the same bus. This report analyzes this situation to address those concerns.

Differential Signal

CAN is a differential bus where complementary signals are sent over two wires and the voltage difference between the two wires defines the logical state of the bus. The differential CAN receiver monitors this voltage difference and outputs the bus state with a single-ended output signal.

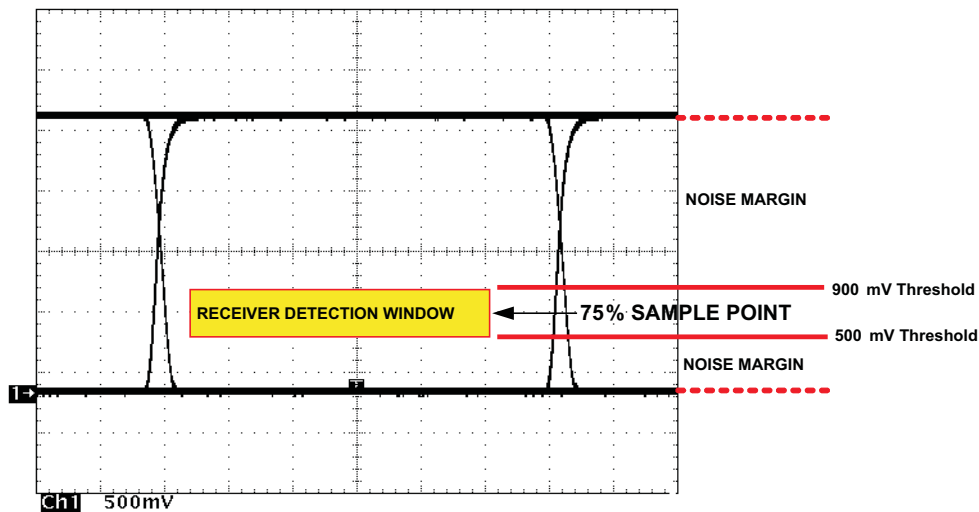

Figure 26. Typical SN65HVD230 Differential Output Voltage Waveform

The CAN driver creates the difference voltage between CANH and CANL in the dominant state. The dominant differential output of the SN65HVD230 is greater than 1.5 V and less than 3 V across a 60-ohm load. The minimum required by ISO 11898 is 1.5 V and maximum is 3 V. These are the same limiting values for 5-V supplied CAN transceivers. The bus termination resistors drive the recessive bus state and not the CAN driver.

A CAN receiver is required to output a recessive state with less than 500 mV and a dominant state with more than 900 mV difference voltage on its bus inputs. The CAN receiver must do this with common-mode input voltages from -2 V to 7 V. The SN65HVD230 family receivers meet these same input specifications as 5-V supplied receivers.

Common-Mode Signal

A common-mode signal is an average voltage of the two signal wires that the differential receiver rejects. The common-mode signal comes from the CAN driver, ground noise, and coupled bus noise. Obviously, the supply voltage of the CAN transceiver has nothing to do with noise. The SN65HVD230 family driver lowers the common-mode output in a dominant bit by a couple hundred millivolts from that of most 5-V drivers. While this does not fully comply with ISO 11898, this small variation in the driver common-mode output is rejected by differential receivers and does not effect data, signal noise margins or error rates.

Interoperability of 3.3-V CAN in 5-V CAN Systems

The 3.3-V supplied SN65HVD23x family of CAN transceivers are electrically interchangeable with 5-V CAN transceivers. The differential output is the same. The recessive common-mode output is the same. The dominant common-mode output voltage is a couple hundred millivolts lower than 5-V supplied drivers, while the receivers exhibit identical specifications as 5-V devices.

Electrical interoperability does not assure interchangeability however. Most implementers of CAN buses recognize that ISO 11898 does not sufficiently specify the electrical layer and that strict standard compliance alone does not ensure interchangeability. This comes only with thorough equipment testing.

BUS CABLE

The ISO-11898 Standard specifies a maximum bus length of 40 m and maximum stub length of 0.3 m with a maximum of 30 nodes. However, with careful design, users can have longer cables, longer stub lengths, and many more nodes to a bus. A large number of nodes requires a transceiver with high input impedance such as the SN65HVD233.

The standard specifies the interconnect to be a single twisted-pair cable (shielded or unshielded) with 120-Ω characteristic impedance (Z_0). Resistors equal to the characteristic impedance of the line terminate both ends of the cable to prevent signal reflections. Unterminated drop-lines (stubs) connecting nodes to the bus should be kept as short as possible to minimize signal reflections.

SLOPE CONTROL

The rise and fall slope of the SN65HVD233 driver output can be adjusted by connecting a resistor from R_s (pin 8) to ground (GND), or to a low-level input voltage as shown in Figure 27.

The slope of the driver output signal is proportional to the pin's output current. This slope control is implemented with an external resistor value of 10 kΩ to achieve a ≈ 15 V/μs slew rate, and up to 100 kΩ to achieve a ≈ 2.0 V/μs slew rate as displayed in Figure 28. Typical driver output waveforms with slope control are displayed in Figure 29.

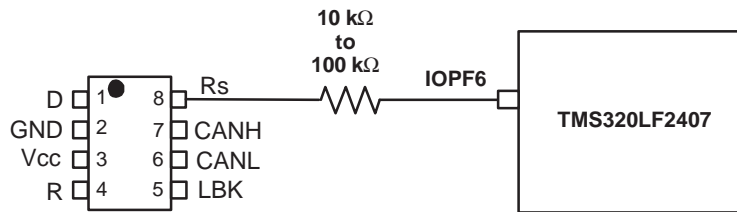

Figure 27. Slope Control/Standby Connection to a DSP

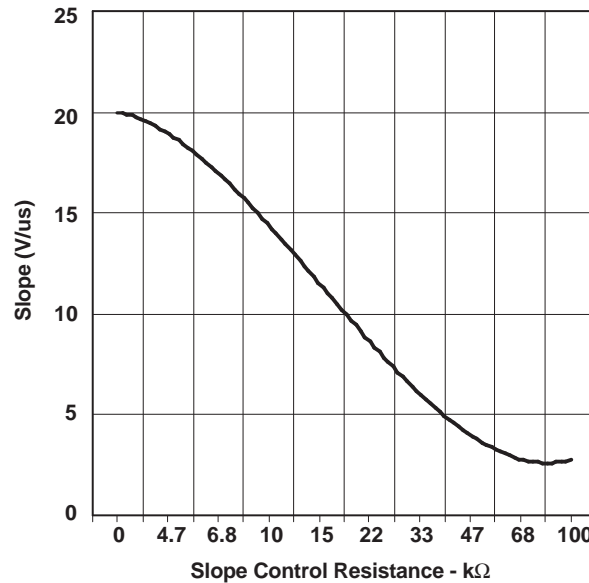

Figure 28. SN65HVD233 Driver Output Signal Slope vs Slope Control Resistance Value

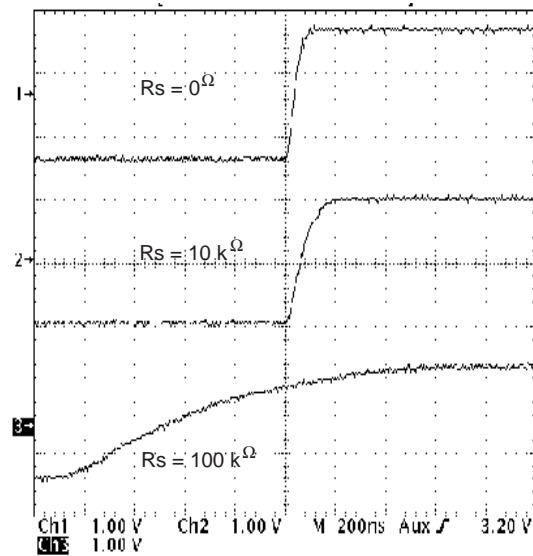

Figure 29. Typical SN65HVD233 250-kbps Output Pulse Waveforms With Slope Control

STANDBY

If a high-level input ($> 0.75 V_{CC}$) is applied to R_s (pin 8), the circuit enters a low-current, *listen only* standby mode during which the driver is switched off and the receiver remains active. The local controller can reverse this low-power standby mode when the rising edge of a dominant state (bus differential voltage > 900 mV typical) occurs on the bus.

PACKAGING INFORMATION

Orderable Device	Status ⁽¹⁾	Package Type	Package Drawing	Pins	Package Qty	Eco Plan ⁽²⁾	Lead/Ball Finish	MSL Peak Temp ⁽³⁾
SN65HVD233MDREP	ACTIVE	SOIC	D	8	2500	Green (RoHS & no Sb/Br)	CU NIPDAU	Level-1-260C-UNLIM
V62/09611-01XE	ACTIVE	SOIC	D	8	2500	Green (RoHS & no Sb/Br)	CU NIPDAU	Level-1-260C-UNLIM

⁽¹⁾ The marketing status values are defined as follows:

ACTIVE: Product device recommended for new designs.

LIFEBUY: TI has announced that the device will be discontinued, and a lifetime-buy period is in effect.

NRND: Not recommended for new designs. Device is in production to support existing customers, but TI does not recommend using this part in a new design.

PREVIEW: Device has been announced but is not in production. Samples may or may not be available.

OBsolete: TI has discontinued the production of the device.

⁽²⁾ Eco Plan - The planned eco-friendly classification: Pb-Free (RoHS), Pb-Free (RoHS Exempt), or Green (RoHS & no Sb/Br) - please check <http://www.ti.com/productcontent> for the latest availability information and additional product content details.

TBD: The Pb-Free/Green conversion plan has not been defined.

Pb-Free (RoHS): TI's terms "Lead-Free" or "Pb-Free" mean semiconductor products that are compatible with the current RoHS requirements for all 6 substances, including the requirement that lead not exceed 0.1% by weight in homogeneous materials. Where designed to be soldered at high temperatures, TI Pb-Free products are suitable for use in specified lead-free processes.

Pb-Free (RoHS Exempt): This component has a RoHS exemption for either 1) lead-based flip-chip solder bumps used between the die and package, or 2) lead-based die adhesive used between the die and leadframe. The component is otherwise considered Pb-Free (RoHS compatible) as defined above.

Green (RoHS & no Sb/Br): TI defines "Green" to mean Pb-Free (RoHS compatible), and free of Bromine (Br) and Antimony (Sb) based flame retardants (Br or Sb do not exceed 0.1% by weight in homogeneous material)

⁽³⁾ MSL, Peak Temp. -- The Moisture Sensitivity Level rating according to the JEDEC industry standard classifications, and peak solder temperature.

Important Information and Disclaimer:The information provided on this page represents TI's knowledge and belief as of the date that it is provided. TI bases its knowledge and belief on information provided by third parties, and makes no representation or warranty as to the accuracy of such information. Efforts are underway to better integrate information from third parties. TI has taken and continues to take reasonable steps to provide representative and accurate information but may not have conducted destructive testing or chemical analysis on incoming materials and chemicals. TI and TI suppliers consider certain information to be proprietary, and thus CAS numbers and other limited information may not be available for release.

In no event shall TI's liability arising out of such information exceed the total purchase price of the TI part(s) at issue in this document sold by TI to Customer on an annual basis.

OTHER QUALIFIED VERSIONS OF SN65HVD233-EP :

- Catalog: [SN65HVD233](#)

NOTE: Qualified Version Definitions:

- Catalog - TI's standard catalog product

D (R-PDSO-G8)

PLASTIC SMALL-OUTLINE PACKAGE

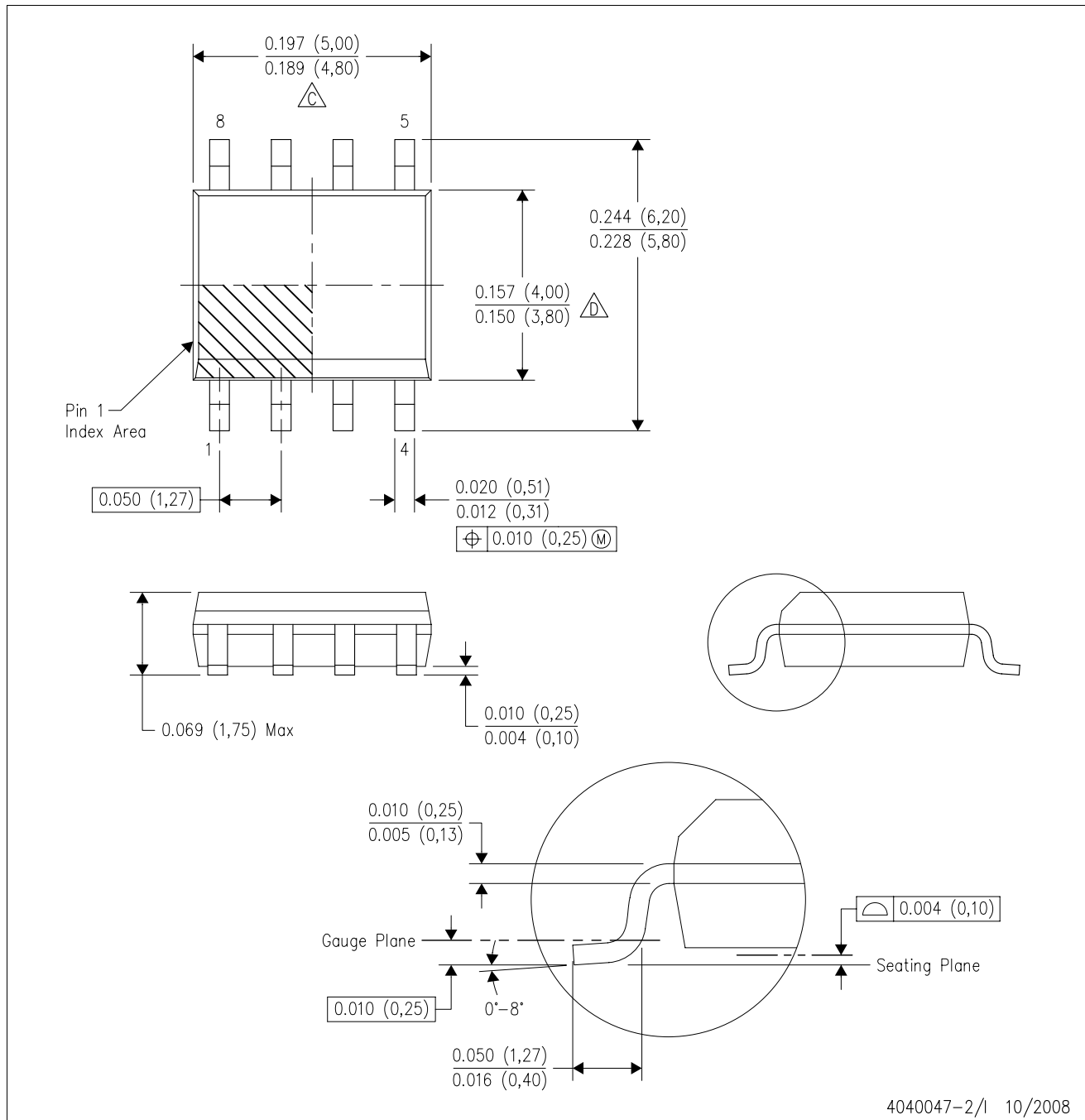

NOTES: A. All linear dimensions are in inches (millimeters).
 B. This drawing is subject to change without notice.
 C. Body length does not include mold flash, protrusions, or gate burrs. Mold flash, protrusions, or gate burrs shall not exceed .006 (0,15) per end.
 D. Body width does not include interlead flash. Interlead flash shall not exceed .017 (0,43) per side.
 E. Reference JEDEC MS-012 variation AA.

IMPORTANT NOTICE

Texas Instruments Incorporated and its subsidiaries (TI) reserve the right to make corrections, modifications, enhancements, improvements, and other changes to its products and services at any time and to discontinue any product or service without notice. Customers should obtain the latest relevant information before placing orders and should verify that such information is current and complete. All products are sold subject to TI's terms and conditions of sale supplied at the time of order acknowledgment.

TI warrants performance of its hardware products to the specifications applicable at the time of sale in accordance with TI's standard warranty. Testing and other quality control techniques are used to the extent TI deems necessary to support this warranty. Except where mandated by government requirements, testing of all parameters of each product is not necessarily performed.

TI assumes no liability for applications assistance or customer product design. Customers are responsible for their products and applications using TI components. To minimize the risks associated with customer products and applications, customers should provide adequate design and operating safeguards.

TI does not warrant or represent that any license, either express or implied, is granted under any TI patent right, copyright, mask work right, or other TI intellectual property right relating to any combination, machine, or process in which TI products or services are used. Information published by TI regarding third-party products or services does not constitute a license from TI to use such products or services or a warranty or endorsement thereof. Use of such information may require a license from a third party under the patents or other intellectual property of the third party, or a license from TI under the patents or other intellectual property of TI.

Reproduction of TI information in TI data books or data sheets is permissible only if reproduction is without alteration and is accompanied by all associated warranties, conditions, limitations, and notices. Reproduction of this information with alteration is an unfair and deceptive business practice. TI is not responsible or liable for such altered documentation. Information of third parties may be subject to additional restrictions.

Resale of TI products or services with statements different from or beyond the parameters stated by TI for that product or service voids all express and any implied warranties for the associated TI product or service and is an unfair and deceptive business practice. TI is not responsible or liable for any such statements.

TI products are not authorized for use in safety-critical applications (such as life support) where a failure of the TI product would reasonably be expected to cause severe personal injury or death, unless officers of the parties have executed an agreement specifically governing such use. Buyers represent that they have all necessary expertise in the safety and regulatory ramifications of their applications, and acknowledge and agree that they are solely responsible for all legal, regulatory and safety-related requirements concerning their products and any use of TI products in such safety-critical applications, notwithstanding any applications-related information or support that may be provided by TI. Further, Buyers must fully indemnify TI and its representatives against any damages arising out of the use of TI products in such safety-critical applications.

TI products are neither designed nor intended for use in military/aerospace applications or environments unless the TI products are specifically designated by TI as military-grade or "enhanced plastic." Only products designated by TI as military-grade meet military specifications. Buyers acknowledge and agree that any such use of TI products which TI has not designated as military-grade is solely at the Buyer's risk, and that they are solely responsible for compliance with all legal and regulatory requirements in connection with such use.

TI products are neither designed nor intended for use in automotive applications or environments unless the specific TI products are designated by TI as compliant with ISO/TS 16949 requirements. Buyers acknowledge and agree that, if they use any non-designated products in automotive applications, TI will not be responsible for any failure to meet such requirements.

Following are URLs where you can obtain information on other Texas Instruments products and application solutions:

Products

Amplifiers	amplifier.ti.com
Data Converters	dataconverter.ti.com
DSP	dsp.ti.com
Clocks and Timers	www.ti.com/clocks
Interface	interface.ti.com
Logic	logic.ti.com
Power Mgmt	power.ti.com
Microcontrollers	microcontroller.ti.com
RFID	www.ti-rfid.com
RF/IF and ZigBee® Solutions	www.ti.com/lprf

Applications

Audio	www.ti.com/audio
Automotive	www.ti.com/automotive
Broadband	www.ti.com/broadband
Digital Control	www.ti.com/digitalcontrol
Medical	www.ti.com/medical
Military	www.ti.com/military
Optical Networking	www.ti.com/opticalnetwork
Security	www.ti.com/security
Telephony	www.ti.com/telephony
Video & Imaging	www.ti.com/video
Wireless	www.ti.com/wireless

Mailing Address: Texas Instruments, Post Office Box 655303, Dallas, Texas 75265
Copyright © 2008, Texas Instruments Incorporated