

Motor Controllers

AC Semiconductor Motor Controller

Type RSHR MIDI



- Soft starting and stopping of 3-phase induction squirrel cage motors
- 2-phase control with integral bypassing of semiconductors
- Low inrush and reduced vibration during starting
- Rated operational voltage: up to 600 VAC, 50/60Hz
- Rated operational current: up to 18A AC-53b
- Multivoltage option with a range of 190 - 530 VAC*
- LED status indicators
- Optional device over-temperature protection
- Optional auxiliary relay for end of ramp
- DIN rail mounting

* requires external supply

Product Description

The RSHR Midi is a compact easy-to-use AC semiconductor motor controller. With this controller 3-phase motors with nominal currents up to 18A can be soft started and/or soft stopped. The RSHR Midi controls 2 phases only, one phase is continuously connected to the load. Soft starting and soft stopping is achieved by controlling the motor voltage. During running operation the semiconductors

are bypassed by internal electromechanical relays. Starting and stopping time as well as initial torque can be independently adjusted by built-in potentiometers. LEDs indicate the status of the controller including an alarm status in case of over-temperature in the RSHR..V21 models. The RSHR Midi comes with an integrated heatsink and is ready to mount on DIN rail.

Ordering Key

RSH R 48 18 B V21

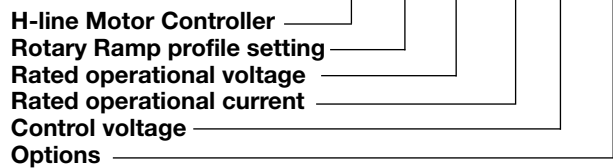

Type Selection

Type	Rated Operational Voltage U_e	Rated Operational Current I_e	Control Voltage U_c	Options
RSHR: H-line motor controller with rotary settings	22: 127/220VACrms, 50/60Hz 40: 230/400VACrms, 50/60Hz 48: 277/480VACrms, 50/60Hz 60: 346/600VACrms, 50/60Hz M: 190-530VACrms, 50/60Hz	06: 6A AC-53b 12: 12A AC-53b 18: 18A AC-53b	B: 24 to 110VAC/DC & 110 to 480VAC	V20: Basic V21: End of Ramp Relay & Over-Temperature Protection

Selection Guide

Rated operational voltage U_e	Rated operational current I_e		
	6A AC-53b	12A AC-53b	18A AC-53b
220VACrms	RSHR2206BV20	RSHR2212BV20	RSHR2218BV20
400VACrms	RSHR4006BV20	RSHR4012BV20	RSHR4018BV20
480VACrms	RSHR4806BV20	RSHR4812BV20	RSHR4818BV20
600VACrms	RSHR6006BV20	RSHR6012BV20	RSHR6018BV20
190-530VACrms	RSHRM06BV20	RSHRM12BV20	RSHRM18BV20

Load Ratings

		RSHR22..BV.. RSHR40..BV.. RSHR48..BV.. RSHRM..BV..	RSHR2218BV.. RSHR4018BV.. RSHR4818BV.. RSHRM18BV..	RSHR60..BV..
IEC rated operational current I _e (AC-53b)	RSHR..06... RSHR..12... RSHR..18...	6A 12A	18A	6A 12A 18A
Overload cycle according to EN/IEC 60947-4-2 @ 40°C surrounding temp.	RSHR..06... RSHR..12... RSHR..18..	6A: AC-53b:4-5:4 12A: AC-53b:4-5:50	18A: AC-53b:4-5:50	6A: AC-53b: 4-5:3 12A: AC-53b:4-5:14 18A: AC-53b:4-5:50
Overload cycle according to EN/IEC 60947-4-2 @ 50°C surrounding temp.	RSHR..06... RSHR..12... RSHR..18..	6A: AC-53b:4-5:26 12A: AC-53b:4-5:62	18A: AC-53b:4-5:62	6A: AC-53b: 4-5:8 12A: AC-53b:4-5:26 18A: AC-53b:4-5:62
Overload cycle according to EN/IEC 60947-4-2 @ 60°C surrounding temp.	RSHR..06... RSHR..12... RSHR..18...	6A: AC-53b:4-5:62 12A: AC-53b:4-5:80	18A: AC-53b:4-5:110	6A: AC-53b: 4-5:26 12A: AC-53b:4-5:50 18A: AC-53b:4-5:110
Number of starts per hour @40/50/60°C	RSHR..06... RSHR..12... RSHR..18...	250/ 100/ 50 60/50/40	60/ 50/ 30	275/ 200/ 100 150/ 100/ 60 60/ 50/ 30
Minimum load rating		0.25kW	0.25kW	0.25kW

Motor Ratings

		6A	12A	18A
IEC rated operational current I _e (AC-53b)				
Assigned motor rating @60°C/UL rating @60°C	220VACrms 400VACrms 480VACrms 600VACrms	1.1kW/ 1.5HP 2.2kW/ 3HP 2.2kW/ 5HP 3kW/ 5HP	3kW/ 3HP 5.5kW/ 7.5HP 5.5kW/ 7.5HP 7.5kW/ 10HP	4kW/ 5HP 7.5kW/ 10 HP 7.5kW/ 10HP 11kW/ 15HP

General Specifications

Ramp up time	0.5...10s +/- 1.5s on max.
Ramp down time	0.5...20s +/- 4s on max.
Initial torque	0...85%
Status indicator LEDs	
Power supply ON	LED, green
Ramping	LED, yellow
Bypass relay ON	LED, yellow
Over-temperature alarm*	LED, red
Auxiliary relay*	Normally open (11, 12)
Auxiliary relay contact capacity*	3A, 250VAC 3A, 30VDC
Form designation	1
Weight	800g (approx.)
Mounting	DIN Rail 35mm
Housing material	Polyamide

Input Specifications

Rated control input voltage U _c	A1:A2	24 - 110VDC/AC
	A1:A3	110 - 480VAC
Rated AC frequency	50/60Hz +/-10%	
Max. control input current	A1:A2	5mA
	A1:A3	5mA
Min. control input current	A1:A2	1mA
	A1:A3	1mA
Dielectric strength		
Dielectric withstand voltage	3.5 kVrms	
Input to heatsink	3.5 kVrms	
Rated impulse withstand voltage	6 kV (1.2/50us)	

Environmental Specifications

Operating temperature	-20°C to +60°C (-4°F to +140°F)
Storage temperature	-50°C to +85°C (-58°F to +185°F)
Relative humidity	<95% non-condensing @40°C
Pollution Degree	3
Degree of Protection	IP20 (EN/IEC 60529)

Installation category	III
Installation Altitude	Above 1000m derate linearly by 1% of unit FLC per 100m to a maximum altitude of 2000m
Vibration	
Sinosodial (IEC 60068-2-6)	13 to 25Hz: 2.0mm peak 25 to 150Hz: 20m/s ²

Supply Specification

Rated operational voltage	
Ue through L1, L2 L3	RSHR22.. 127/220VAC -15% / +10% RSHR40.. 230/400VAC -15% / +10% RSHR48.. 277/480VAC -15% / +10% RSHR60.. 346/600VAC -15% / +10% RSHRM 190-530VAC
Rated AC frequency	50/60Hz +/-10%
Rated insulation voltage	630V, accord. to EN 60947-1
Dielectric strength	
Dielectric withstand voltage	
Supply to input	4 kVrms
Supply to heatsink	4 kVrms
Supply to external supply	2.5 kVrms
Rated impulse withstand voltage	6 kV (1.2/50us)

External Supply Specifications

External supply voltage Us, A4:A5*	24VDC/AC -15% / +10%
Rated AC frequency	50/60Hz +/-10%
Maximum supply current	265mAAC, 140mADC
Minimum supply current	195mAAC, 100mADC
Dielectric strength	
Dielectric withstand voltage	
Supply to input	2.5 kVrms
Supply to heatsink	2.5 kVrms
Rated impulse withstand voltage	6 kV (1.2/50us)

* Applicable to RSHRM models only

Conductor Data

Line conductors: L1, L2, L3, T1, T2, T3 according to EN 60947-1	
flexible	2.5 10mm ² 2.5 2 x 4mm ²
rigid (solid or stranded)	2.5 10mm ²
flexible with ferrule	2.5 10mm ²
UL/CSA rated data	
flexible	AWG14...8 AWG14...2 x 10
rigid (solid or stranded)	AWG14...8
Terminal screws	6xM4 (cage clamp)
Tightening torque	2.5Nm (22lb.in) with Posidrive bit 2
Stripping length	8.0mm

Secondary conductors: A1, A2, A3, A4, A5, 11, 12 according to EN 60998	
flexible	0.5 1.5mm ²
flexible with ferrule	0.5 1.5mm ²
rigid (solid)	0.5 2.5mm ²
UL/CSA rated data	AWG22...12
Terminal screws	7xM3 (cage clamp)
Tightening torque	0.5Nm (4.5lb.in) with Philips bit 0
Stripping length	6.0mm

Standards

Approvals	UL, cUL listed (E172877)	Fast transient immunity (EN 61000-4-4)	Output: 2kV, PC1 (4kV, PC2)
Markings	CE	Input: 2kV, PC1	
EMC (Electromagnetic compatibility) accord. to EN/IEC 60947-4-2		Surge immunity (EN 61000-4-5)	
Wire conducted emission	Class A	Output: line to line	1kV, PC1
Radiated emission	Class A	line to ground	2kV, PC1
ESD Immunity (EN 61000-4-2)	4kV contact, PC2 8kV air discharge, PC1	Input: line to line	1kV, PC2 (500V, PC1)
		line to ground	2kV, PC2 (500V, PC1)
Radiated RF immunity (EN 61000-4-3)	10V/m, PC1 (80-1000MHz)	Conducted RF immunity (EN 61000-4-6)	140dBuV, PC1 (0.15-80MHz)
Voltage dips and interruptions (EN 61000-4-11)	0% Ue & Uc, 20ms, PC2 40% Ue & Uc, 200ms, PC2 70% Ue & Uc, 5000ms, PC2		

Note: EMC testing was performed with the RSHR connected to representative motor loads of 1.1/ 4.0kW. The EMC performance of the controller would eventually have to be evaluated with the controller connected and fitted as part of the complete system in the end application.

Terminal Diagram

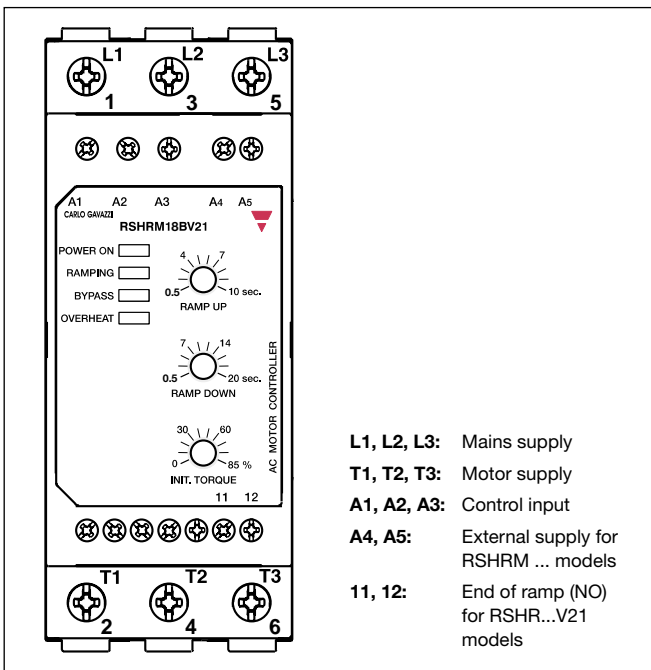

Dimensions

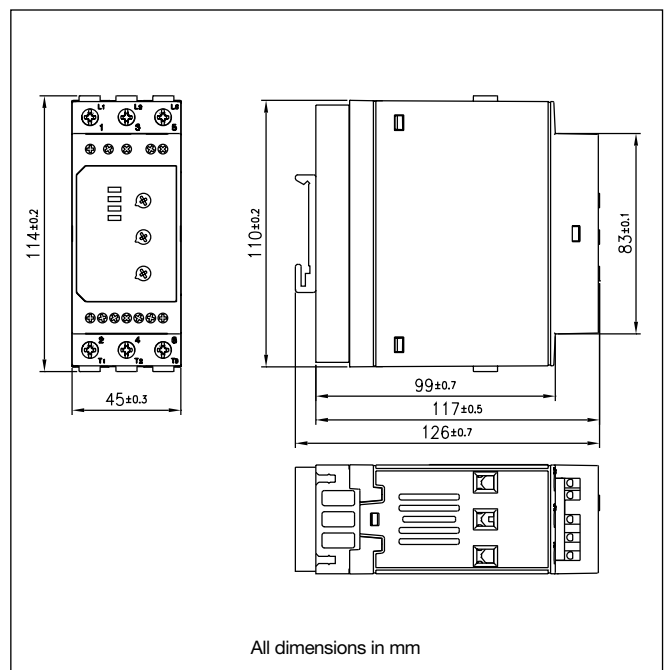

Connection Diagram

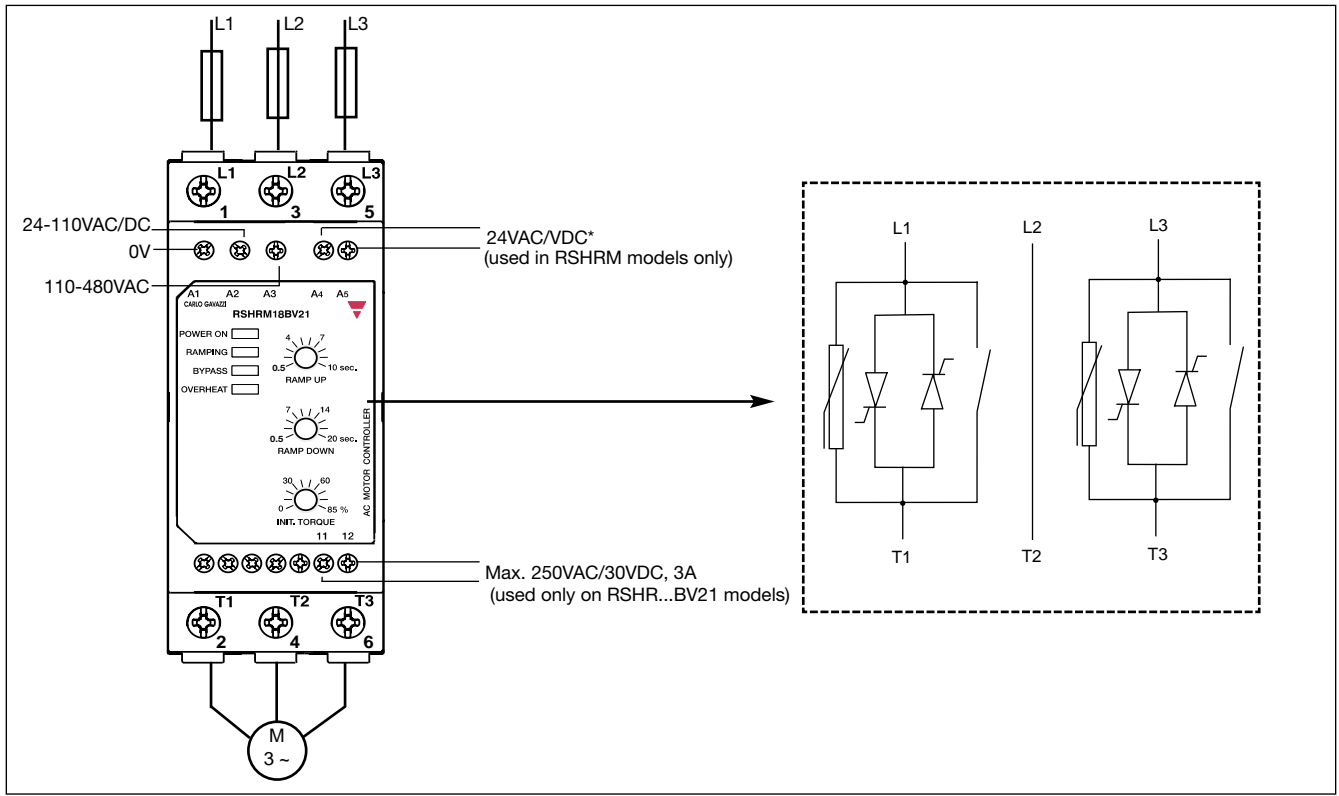

* For the 24VDC external supply, CG power supply model SPD24051 can be used

Short circuit Protection (according to EN/IEC 60947-4-2 and UL 508)

	RSHR..06BV21	RSHR..12BV21	RSHR..18BV21
Type of coordination: 1			
UL rated short circuit current	5kA when protected by RK5 fuses*	10kA when protected by RK5 fuses*	10kA when protected by RK5 fuses
RK5 fuse			
220VACrms	TRS12R 12A	TRS20R 20A	TRS30R 30A
400VACrms	TRS12R 12A	TRS30R 30A	TRS35R 35A
480VACrms	TRS12R 12A	TRS20R 20A	TRS30R 30A
600VACrms	TRS12R 12A	TRS20R 20A	TRS35R 35A
Type of coordination: 2			
Rated short circuit current	10kA when protected by semiconductor fuses	10kA when protected by semiconductor fuses	10kA when protected by semiconductor fuses
Semiconductor fuse	Ferraz Shawmut 25A, Class URC Art. No. 6.9 CP gRC 14.51 25	Ferraz Shawmut 40A, Class URC Art. No. 6.9 CP gRC 14.51 40	Ferraz Shawmut 40A, Class URC Art. No. 6.9 CP gRC 14.51 40

* 10kA for RSHR60 models

Operation Diagram

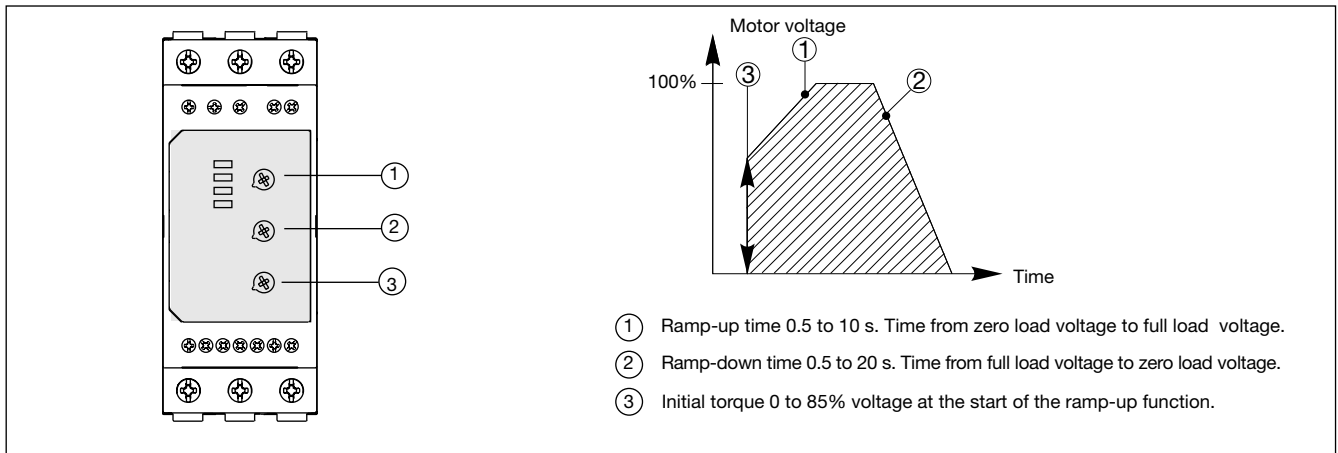

Operation Diagrams for RSHR MIDI

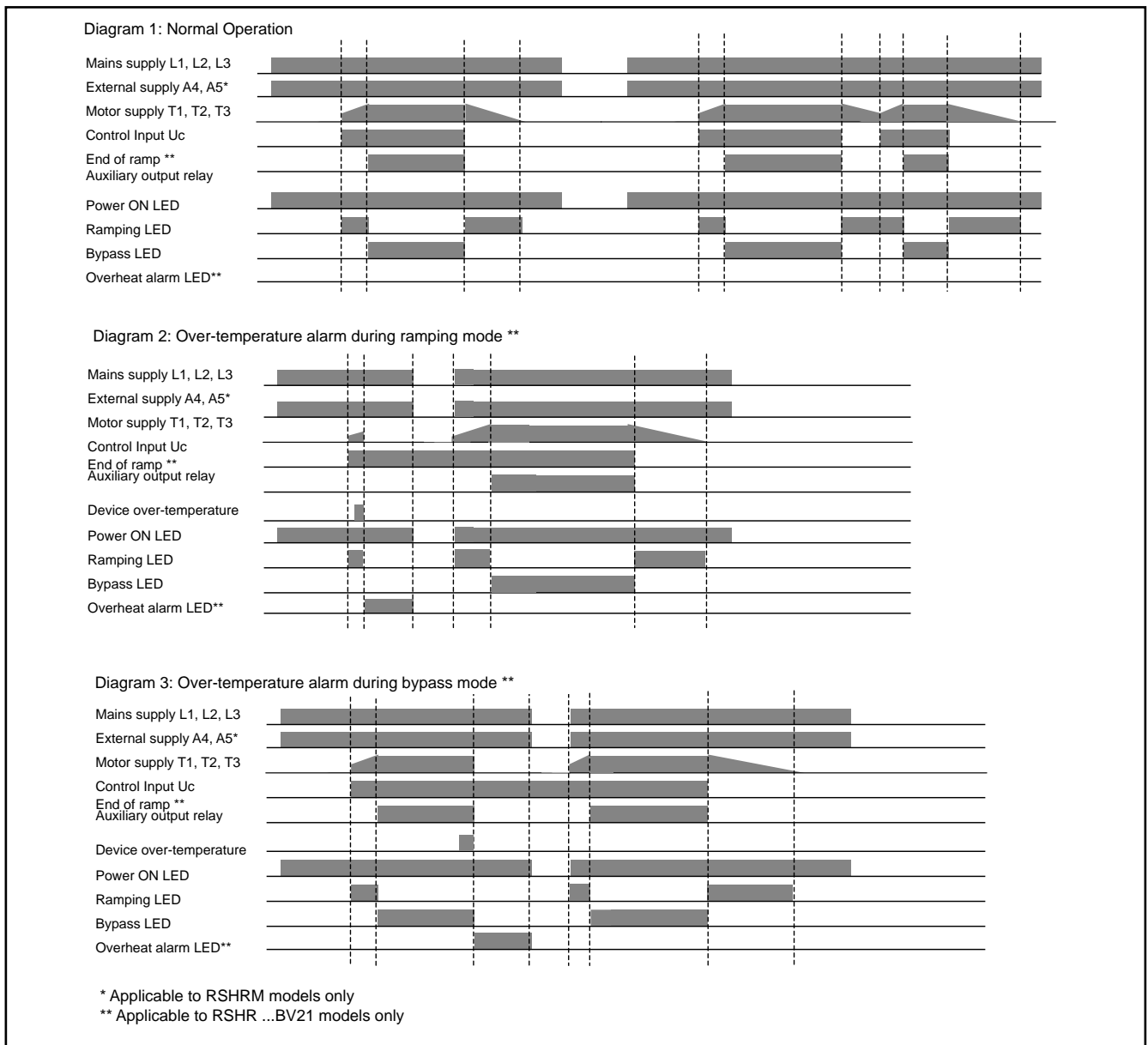

Note: for proper operation of RSHRM models always remove mains supply voltage before switching off external power supply.

Wiring Diagram

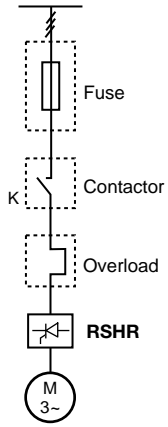

Fig. 1a

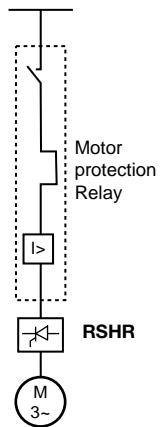

Fig. 2a

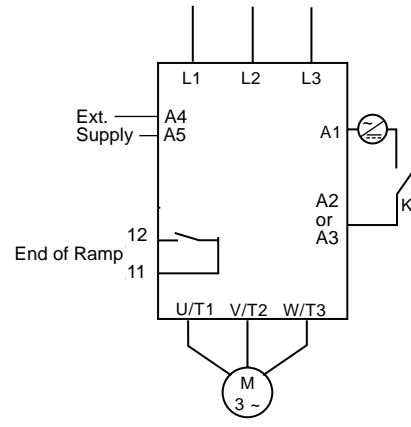

Fig. 3a

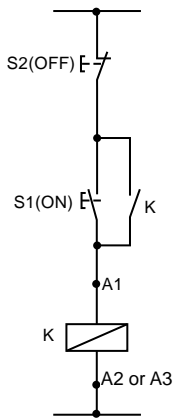

Fig. 4a

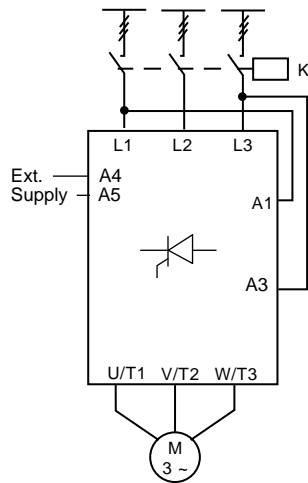

Fig. 5a

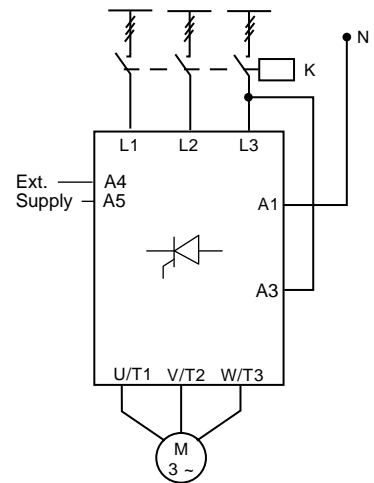
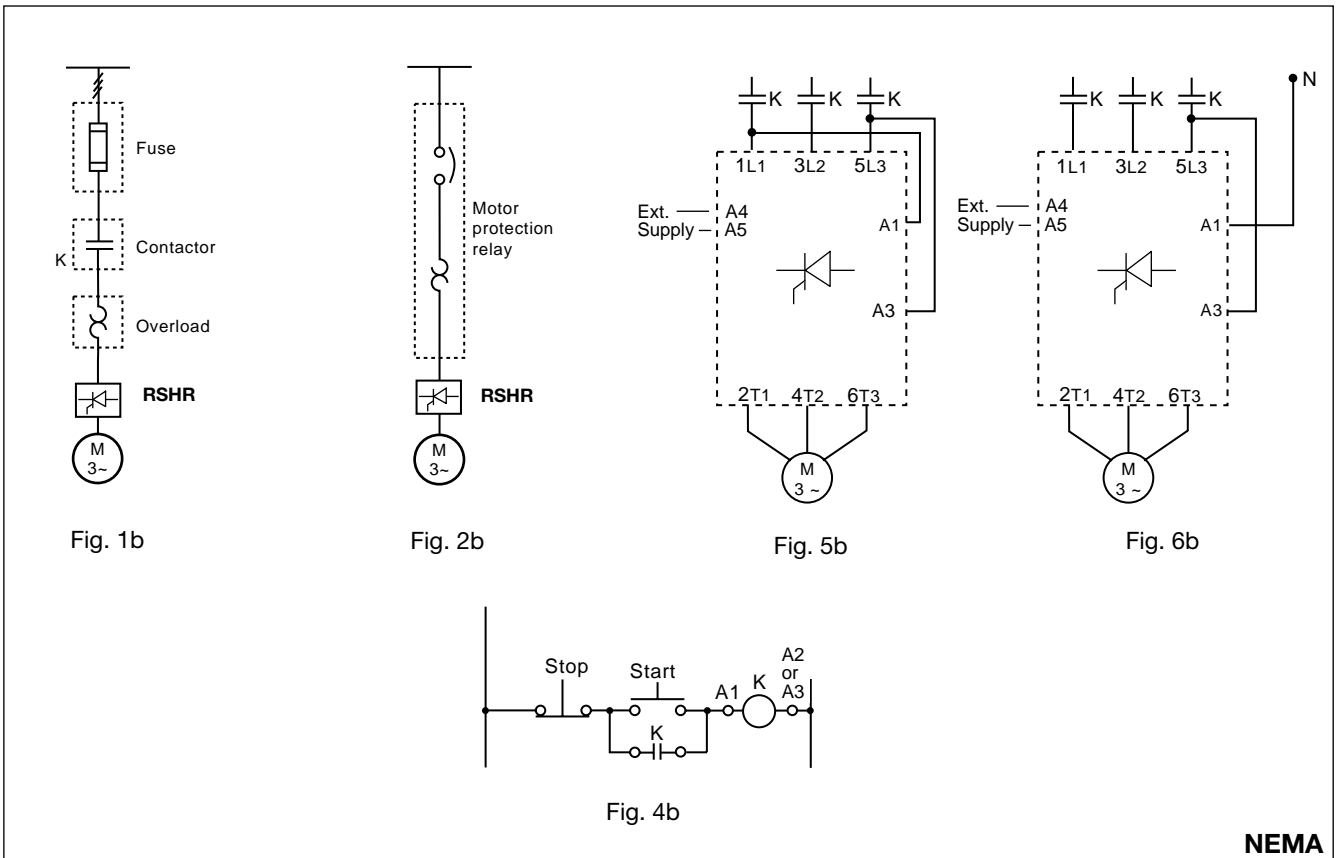

Fig. 6a

Wiring Diagram (cont.)



NEMA

The motor controller provides by-passing of the semiconductors during running operation. Therefore the semiconductors can only be damaged by short-circuit currents during ramp-up and ramp-down. Please note that the motor controller does not isolate the motor from the mains.

Figure 1: Protection of the device when using fuses.
Protection with semiconductor fuses is intended to protect the motor feeder and motor controller from damage due to short-circuit.

Figure 2: Protection using a thermal-magnetic motor protection relay.
The motor feeder is protected but damage to the motor controller is possible. When motor failure occurs, if part of the motor winding limits the fault current and the motor feeder is protected, this type of protection can be considered acceptable.

Figure 3: Secondary conductors.
3.1: Control using a 2-position switch.
When K is closed, the control input is supplied to A1, A2 or A3 and soft starting of the

motor is performed. When K is opened, soft stopping is performed.

3.2: Auxiliary Relay (For RSHR...BV21 models)
The End of Ramp relay 11, 12 (NO) can be used in series with the supply to the coil of an external bypass contactor.

Figure 4: Control using ON and OFF push buttons
Pushing S1 soft starts the RSHR. Pushing S2 soft stops the RSHR. K is an auxiliary contact of the mains contactor.

Figure 5: Control using 2 phases
Connecting input A1, A3 to two of the incoming lines will soft start the motor when K is operated. When K is switched off, the motor will stop (no soft stop). This configuration does not apply to the RSHR60.... versions.

Figure 6: Control when using operational voltage greater than 480V
Connecting A1 to Neutral and A3 to one of the incoming phases (or vice-versa) will soft start the motor when K is closed. When K is opened, the motor will stop (no soft stop).

Accessories - External Power Supply 24VDC - SPD 24051

Rated input voltage	100-240	Voltage trim range	21.6 - 28.8VDC
Voltage range	AC 90 - 265VAC DC 120 - 370VDC	Output voltage accuracy	± 1%
Frequency range	47 - 63Hz	Output current	0.21A

For further details refer to Carlo Gavazzi SPD series datasheet