

## FEATURES

- Available in 8-Pin SO Package
- 50 $\mu$ A Max Supply Current per Amplifier
- 70 $\mu$ V Max Offset Voltage
- 180 $\mu$ A Max Offset Voltage in 8-Pin SO
- 250pA Max Offset Current
- 0.6 $\mu$ V<sub>P-P</sub>, 0.1Hz to 10Hz Voltage Noise
- 3pA<sub>P-P</sub>, 0.1Hz to 10Hz Current Noise
- 0.4 $\mu$ V/ $^{\circ}$ C Offset Voltage Drift
- 200kHz Gain Bandwidth Product
- 0.07V/ $\mu$ s Slew Rate
- Single Supply Operation
  - Input Voltage Range Includes Ground
  - Output Swings to Ground while Sinking Current
  - No Pull-Down Resistors Needed
- Output Sources and Sinks 5mA Load Current

## APPLICATIONS

- Battery or Solar-Powered Systems
  - Portable Instrumentation
  - Remote Sensor Amplifier
  - Satellite Circuitry
- Micropower Sample-and-Hold
- Thermocouple Amplifier
- Micropower Filters

## DESCRIPTION

The LT<sup>®</sup>1078 is a micropower dual op amp in 8-pin packages including the small outline surface mount package. The LT1079 is a micropower quad op amp offered in the standard 14-pin packages. Both devices are optimized for single supply operation at 5V.  $\pm$ 15V specifications are also provided.

Micropower performance of competing devices is achieved at the expense of seriously degrading precision, noise, speed and output drive specifications. The design effort of the LT1078/LT1079 was concentrated on reducing supply current without sacrificing other parameters. The offset voltage achieved is the lowest on any dual or quad nonchopper stabilized op amp—micropower or otherwise. Offset current, voltage and current noise, slew rate and gain bandwidth product are all two to ten times better than on previous micropower op amps.

The 1/f corner of the voltage noise spectrum is at 0.7Hz, at least three times lower than on any monolithic op amp. This results in low frequency (0.1Hz to 10Hz) noise performance which can only be found on devices with an order of magnitude higher supply current.

Both the LT1078 and LT1079 can be operated from a single supply (as low as one lithium cell or two Ni-Cad batteries). The input range goes below ground. The all-NPN output stage swings to within a few millivolts of ground while sinking current—no power consuming pull down resistors are needed.

LT, LTC and LT are registered trademarks of Linear Technology Corporation.

Single Battery, Micropower, Gain = 100, Instrumentation Amplifier

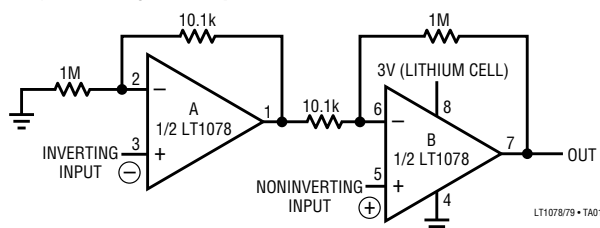

**TYPICAL PERFORMANCE**  
 INPUT OFFSET VOLTAGE = 40 $\mu$ V  
 INPUT OFFSET CURRENT = 0.2nA  
 TOTAL POWER DISSIPATION = 240 $\mu$ W  
 COMMON MODE REJECTION = 110dB (AMPLIFIER LIMITED)  
 GAIN BANDWIDTH PRODUCT = 200kHz

OUTPUT NOISE = 85  $\mu$ V<sub>P-P</sub> 0.1Hz TO 10Hz  
 = 300  $\mu$ V<sub>RMS</sub> OVER FULL BANDWIDTH  
 INPUT RANGE = 0.03V TO 1.8V  
 OUTPUT RANGE = 0.03V TO 2.3V  
 (0.3mV  $\leq$  V<sub>IN+</sub> - V<sub>IN-</sub>  $\leq$  23mV)  
 OUTPUTS SINK CURRENT—NO PULL-DOWN RESISTORS ARE NEEDED

Distribution of Input Offset Voltage (LT1078 and LT1079 in H, J, N Packages)

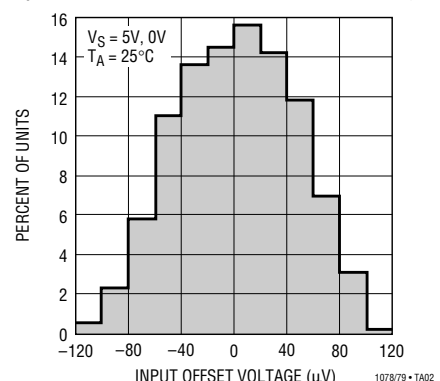

## ABSOLUTE MAXIMUM RATINGS

Supply Voltage .....	$\pm 22\text{V}$	Operating Temperature Range	
Differential Input Voltage .....	$\pm 30\text{V}$	LT1078AM/LT1078M/	
Input Voltage .....	Equal to Positive Supply Voltage	LT1079AM/LT1079M .....	$-55^{\circ}\text{C}$ to $125^{\circ}\text{C}$
	..... 5V Below Negative Supply Voltage	LT1078I/LT1079I .....	$-40^{\circ}\text{C}$ to $85^{\circ}\text{C}$
Output Short-Circuit Duration .....	Indefinite	LT1078AC/LT1078C/LT1078S8/	
Storage Temperature Range		LT1079AC/LT1079C .....	$0^{\circ}\text{C}$ to $70^{\circ}\text{C}$
All Grades .....	$-65^{\circ}\text{C}$ to $150^{\circ}\text{C}$	Lead Temperature (Soldering, 10 sec) .....	$300^{\circ}\text{C}$

## PACKAGE/ORDER INFORMATION

<p>TOP VIEW</p> <p>V<sup>+</sup></p> <p>OUT A 1</p> <p>-IN A 2</p> <p>+IN A 3</p> <p>+IN B 4</p> <p>+IN B 5</p> <p>-IN B 6</p> <p>OUT B 7</p> <p>V<sup>-</sup> (CASE) 8</p> <p>H PACKAGE</p> <p>8-LEAD TO-5 METAL CAN</p> <p><math>T_{JMAX} = 150^{\circ}\text{C}</math>, <math>\theta_{JA} = 150^{\circ}\text{C/W}</math>, <math>\theta_{JC} = 45^{\circ}\text{C/W}</math></p>	<p>TOP VIEW</p> <p>OUT A 1</p> <p>-IN A 2</p> <p>+IN A 3</p> <p>V<sup>-</sup> 4</p> <p>V<sup>+</sup> 8</p> <p>OUT B 7</p> <p>-IN B 6</p> <p>+IN B 5</p> <p>J8 PACKAGE</p> <p>8-LEAD CERAMIC DIP</p> <p>N8 PACKAGE</p> <p>8-LEAD PDIP</p> <p><math>T_{JMAX} = 150^{\circ}\text{C}</math>, <math>\theta_{JA} = 100^{\circ}\text{C/W}</math> (J8)</p> <p><math>T_{JMAX} = 100^{\circ}\text{C}</math>, <math>\theta_{JA} = 130^{\circ}\text{C/W}</math> (N8)</p>	<p>TOP VIEW</p> <p>+IN A 1</p> <p>V<sup>-</sup> 2</p> <p>+IN B 3</p> <p>-IN B 4</p> <p>OUT B 5</p> <p>V<sup>+</sup> 6</p> <p>OUT A 7</p> <p>-IN A 8</p> <p>S8 PACKAGE</p> <p>8-LEAD PLASTIC SO</p> <p>NOTE: THIS PIN CONFIGURATION DIFFERS FROM THE 8-LEAD DIP PIN LOCATIONS. INSTEAD, IT FOLLOWS THE INDUSTRY STANDARD LT1013DS8 SO PACKAGE CONFIGURATION. FOR SIMILAR PERFORMANCE WITH TRADITIONAL DIP PINOUT, SEE THE LT2078</p> <p><math>T_{JMAX} = 110^{\circ}\text{C}</math>, <math>\theta_{JA} = 220^{\circ}\text{C/W}</math></p>	
ORDER PART NUMBER	ORDER PART NUMBER	ORDER PART NUMBER	
LT1078ACH LT1078MH	LT1078ACN8 LT1078AMJ8 LT1078CN8 LT1078IN8 LT1078MJ8	LT1078IS8 LT1078S8	
		PART MARKING	
		1078	
<p>TOP VIEW</p> <p>OUT A 1</p> <p>-IN A 2</p> <p>+IN A 3</p> <p>V<sup>+</sup> 4</p> <p>+IN B 5</p> <p>-IN B 6</p> <p>OUT B 7</p> <p>OUT D 14</p> <p>-IN D 13</p> <p>+IN D 12</p> <p>V<sup>-</sup> 11</p> <p>+IN C 10</p> <p>-IN C 9</p> <p>OUT C 8</p> <p>J PACKAGE</p> <p>14-LEAD CERAMIC DIP</p> <p>N PACKAGE</p> <p>14-LEAD PDIP</p> <p><math>T_{JMAX} = 150^{\circ}\text{C}</math>, <math>\theta_{JA} = 100^{\circ}\text{C/W}</math> (J)</p> <p><math>T_{JMAX} = 110^{\circ}\text{C}</math>, <math>\theta_{JA} = 130^{\circ}\text{C/W}</math> (N)</p>	ORDER PART NUMBER	<p>TOP VIEW</p> <p>OUT A 1</p> <p>-IN A 2</p> <p>+IN A 3</p> <p>V<sup>+</sup> 4</p> <p>+IN B 5</p> <p>-IN B 6</p> <p>OUT B 7</p> <p>NC 8</p> <p>NC 9</p> <p>OUT C 10</p> <p>-IN C 11</p> <p>+IN C 12</p> <p>V<sup>-</sup> 13</p> <p>+IN D 14</p> <p>-IN D 15</p> <p>OUT D 16</p> <p>SW PACKAGE</p> <p>16-LEAD PLASTIC SO WIDE</p> <p>NOTE: FOR 14-PIN NARROW PACKAGE SEE THE LT2079</p> <p><math>T_{JMAX} = 110^{\circ}\text{C}</math>, <math>\theta_{JA} = 150^{\circ}\text{C/W}</math></p>	ORDER PART NUMBER
	LT1079ACN LT1079CN LT1079IN LT1079MJ	LT1079ISW LT1079SW	

**ELECTRICAL CHARACTERISTICS**  $V_S = 5V, 0V, V_{CM} = 0.1V, V_O = 1.4V, T_A = 25^\circ C$ , unless otherwise noted.

SYMBOL	PARAMETER	CONDITIONS (NOTE 1)	LT1078AC/LT1079AC LT1078AM/LT1079AM			LT1078C/LT1079C LT1078I/LT1079I LT1078M/LT1079M LT1078S8/LT1079SW			UNITS
			MIN	TYP	MAX	MIN	TYP	MAX	
$V_{OS}$	Input Offset Voltage	LT1078 LT1078IS8/LT1078S8 LT1079 LT1079ISW/LT1079SW		30 35	70 100		40 60 40 60	120 180 150 300	$\mu V$ $\mu V$ $\mu V$ $\mu V$
$\frac{\Delta V_{OS}}{\Delta Time}$	Long Term Input Offset Voltage Stability			0.4			0.5		$\mu V/Mo$
$I_{OS}$	Input Offset Current			0.05	0.25		0.05	0.35	nA
$I_B$	Input Bias Current			6	8		6	10	nA
$e_n$	Input Noise Voltage	0.1Hz to 10Hz (Note 2)		0.6	1.2		0.6		$\mu V_{P-P}$
	Input Noise Voltage Density	$f_0 = 10Hz$ (Note 2) $f_0 = 1000Hz$ (Note 2)		29 28	45 37		29 28		$nV\sqrt{Hz}$ $nV\sqrt{Hz}$
$i_n$	Input Noise Current	0.1Hz to 10Hz (Note 2)		2.3	4.0		2.3		$pA_{P-P}$
	Input Noise Current Density	$f_0 = 10Hz$ (Note 2) $f_0 = 1000Hz$		0.06 0.02	0.10		0.06 0.02		$pA\sqrt{Hz}$ $pA\sqrt{Hz}$
	Input Resistance Differential Mode Common Mode	(Note 3)	400	800 6		300	800 6		$M\Omega$ $G\Omega$
	Input Voltage Range		3.5 0	3.8 -0.3		3.5 0	3.8 -0.3		V V
CMRR	Common Mode Rejection Ratio	$V_{CM} = 0V$ to 3.5V	97	110		94	108		dB
PSRR	Power Supply Rejection Ratio	$V_S = 2.3V$ to 12V	102	114		100	114		dB
$A_{VOL}$	Large-Signal Voltage Gain	$V_O = 0.03V$ to 4V, No Load $V_O = 0.03V$ to 3.5V, $R_L = 50k$	200 150	1000 600		150 120	1000 600		V/mV V/mV
	Maximum Output Voltage Swing	Output Low, No Load		3.5	6		3.5	6	mV
		Output Low, 2k to GND		0.55	1.0		0.55	1.0	mV
		Output Low, $I_{SINK} = 100\mu A$		95	130		95	130	mV
		Output High, No Load		4.2	4.4		4.2	4.4	V
		Output High, 2k to GND		3.5	3.9		3.5	3.9	V
SR	Slew Rate	$A_V = 1, V_S = \pm 2.5V$	0.04	0.07		0.04	0.07		V/ $\mu s$
GBW	Gain Bandwidth Product	$f_0 \leq 20kHz$		200			200		kHz
$I_S$	Supply Current per Amplifier			38	50		39	55	$\mu A$
	Channel Separation	$\Delta V_{IN} = 3V, R_L = 10k$		130			130		dB
	Minimum Supply Voltage	(Note 4)		2.2	2.3		2.2	2.3	V

## ELECTRICAL CHARACTERISTICS

$V_S = 5V, 0V, V_{CM} = 0.1V, V_O = 1.4V, -40^\circ C \leq T_A \leq 85^\circ C$  for I grades,  $-55^\circ C \leq T_A \leq 125^\circ C$  for AM/M grades, unless otherwise noted.

SYMBOL	PARAMETER	CONDITIONS		LT1078AM/LT1079AM			LT1078I/LT1079I LT1078M/LT1079M			UNITS
				MIN	TYP	MAX	MIN	TYP	MAX	
$V_{OS}$	Input Offset Voltage	LT1078	●		70	250	95	370	$\mu V$	
		LT1078IS8/LT1079	●		80	280	100	400	$\mu V$	
		LT1079ISW	●				100	560	$\mu V$	
$\frac{\Delta V_{OS}}{\Delta T}$	Input Offset Voltage Drift (Note 5)	LT1078IS8	●		0.4	1.8	0.5	2.5	$\mu V/^\circ C$	
		LT1079ISW	●				0.6	3.5	$\mu V/^\circ C$	
			●				0.7	4.0	$\mu V/^\circ C$	
$I_{OS}$	Input Offset Current	LT1078I/LT1079I	●		0.07	0.50	0.07	0.70	nA	
			●				0.1	1.0	nA	
$I_B$	Input Bias Current		●		7	10	7	12	nA	
CMRR	Common Mode Rejection Ratio	$V_{CM} = 0.05V$ to $3.2V$	●	92	106	88	104		dB	
PSRR	Power Supply Rejection Ratio	$V_S = 3.1V$ to $12V$	●	98	110	94	110		dB	
$A_{VOL}$	Large-Signal Voltage Gain	$V_O = 0.05V$ to $4V$ , No Load	●	110	600	80	600		V/mV	
		$V_O = 0.05V$ to $3.5V, R_L = 50k$	●	80	400	60	400		V/mV	
	Maximum Output Voltage Swing	Output Low, No Load	●		4.5	8	4.5	8	mV	
		Output Low, $I_{SINK} = 100\mu A$	●		125	170	125	170	mV	
		Output High, No Load	●	3.9	4.2	3.9	4.2		V	
		Output High, 2k to GND	●	3.0	3.7	3.0	3.7		V	
$I_S$	Supply Current per Amplifier		●		43	60	45	70	$\mu A$	

$V_S = 5V, 0V, V_{CM} = 0.1V, V_O = 1.4V, 0^\circ C \leq T_A \leq 70^\circ C$ , unless otherwise noted.

SYMBOL	PARAMETER	CONDITIONS		LT1078AC/LT1079AC			LT1078C/LT1079C LT1078S8/LT1079SW			UNITS
				MIN	TYP	MAX	MIN	TYP	MAX	
$V_{OS}$	Input Offset Voltage	LT1078	●		50	150	60	240	$\mu V$	
		LT1079	●		60	180	70	270	$\mu V$	
		LT1078S8	●				85	350	$\mu V$	
		LT1079SW	●				90	480	$\mu V$	
$\frac{\Delta V_{OS}}{\Delta T}$	Input Offset Voltage Drift (Note 5)	LT1078S8	●		0.4	1.8	0.5	2.5	$\mu V/^\circ C$	
		LT1079SW	●				0.6	3.5	$\mu V/^\circ C$	
			●				0.7	4.0	$\mu V/^\circ C$	
$I_{OS}$	Input Offset Current		●		0.06	0.35	0.06	0.50	nA	
$I_B$	Input Bias Current		●		6	9	6	11	nA	
CMRR	Common Mode Rejection Ratio	$V_{CM} = 0V$ to $3.4V$	●	94	108	90	106		dB	
PSRR	Power Supply Rejection Ratio	$V_S = 2.6V$ to $12V$	●	100	112	97	112		dB	
$A_{VOL}$	Large-Signal Voltage Gain	$V_O = 0.05V$ to $4V$ , No Load	●	150	750	110	750		V/mV	
		$V_O = 0.05V$ to $3.5V, R_L = 50k$	●	110	500	80	500		V/mV	
	Maximum Output Voltage Swing	Output Low, No Load	●		4.0	7	4.0	7	mV	
		Output Low, $I_{SINK} = 100\mu A$	●		105	150	105	150	mV	
		Output High, No Load	●	4.1	4.3	4.1	4.3		V	
		Output High, 2k to GND	●	3.3	3.8	3.3	3.8		V	
$I_S$	Supply Current per Amplifier		●		40	55	42	63	$\mu A$	

**ELECTRICAL CHARACTERISTICS**  $V_S = \pm 15V$ ,  $T_A = 25^\circ C$ , unless otherwise noted.

SYMBOL	PARAMETER	CONDITIONS	LT1078AC/LT1079AC LT1078AM/LT1079AM			LT1078C/LT1079C LT1078I/LT1079I LT1078M/LT1079M LT1078S8/LT1079SW			UNITS
			MIN	TYP	MAX	MIN	TYP	MAX	
$V_{OS}$	Input Offset Voltage	(Including LT1078IS8/LT1078S8) LT1079ISW/LT1079SW		50	250		70 80	350 500	$\mu V$ $\mu V$
$I_{OS}$	Input Offset Current			0.05	0.25		0.05	0.35	nA
$I_B$	Input Bias Current			6	8		6	10	nA
	Input Voltage Range		13.5 -15.0	13.8 -15.3		13.5 -15.0	13.8 -15.3		V V
CMRR	Common Mode Rejection Ratio	$V_{CM} = 13.5V, -15V$	100	114		97	114		dB
PSRR	Power Supply Rejection Ratio	$V_S = 5V, 0V$ to $\pm 18V$	102	114		100	114		dB
$A_{VOL}$	Large-Signal Voltage Gain	$V_O = \pm 10V, R_L = 50k$ $V_O = \pm 10V, R_L = 2k$	1000 400	5000 1100		1000 300	5000 1100		V/mV V/mV
$V_{OUT}$	Maximum Output Voltage Swing	$R_L = 50k$ $R_L = 2k$	$\pm 13.0$ $\pm 11.0$	$\pm 14.0$ $\pm 13.2$		$\pm 13.0$ $\pm 11.0$	$\pm 14.0$ $\pm 13.2$		V V
SR	Slew Rate		0.06	0.10		0.06	0.10		V/ $\mu s$
$I_S$	Supply Current per Amplifier			46	65		47	75	$\mu A$

$V_S = \pm 15V$ ,  $-40^\circ C \leq T_A \leq 85^\circ C$  for I grades,  $-55^\circ C \leq T_A \leq 125^\circ C$  for AM/M grades unless otherwise noted.

SYMBOL	PARAMETER	CONDITIONS		LT1078AM/LT1079AM			LT1078I/LT1079I LT1078M/LT1079M			UNITS
				MIN	TYP	MAX	MIN	TYP	MAX	
$V_{OS}$	Input Offset Voltage	(Including LT1078IS8) LT1079ISW	● ●		90	430		120 130	600 825	$\mu V$ $\mu V$
$\frac{\Delta V_{OS}}{\Delta T}$	Input Offset Voltage Drift (Note 5)	LT1078IS8 LT1079ISW	● ● ●		0.5	1.8		0.6 0.7 0.8	2.5 3.8 5.0	$\mu V/^\circ C$ $\mu V/^\circ C$ $\mu V/^\circ C$
$I_{OS}$	Input Offset Current	LT1078I/LT1079I	● ●		0.07	0.50		0.07 0.1	0.70 1.0	nA nA
$I_B$	Input Bias Current		●		7	10		7	12	nA
$A_{VOL}$	Large-Signal Voltage Gain	$V_O = \pm 10V, R_L = 5k$	●	200	700		150	700		V/mV
CMRR	Common Mode Rejection Ratio	$V_{CM} = 13V, -14.9V$	●	94	110		90	110		dB
PSRR	Power Supply Rejection Ratio	$V_S = 5V, 0V$ to $\pm 18V$	●	98	110		94	110		dB
	Maximum Output Voltage Swing	$R_L = 5k$	●	$\pm 11.0$	$\pm 13.5$		$\pm 11.0$	$\pm 13.5$		V
$I_S$	Supply Current per Amplifier		●		52	80		54	95	$\mu A$

**ELECTRICAL CHARACTERISTICS**  $V_S = \pm 15V, 0^\circ C \leq T_A \leq 70^\circ C$ , unless otherwise noted.

SYMBOL	PARAMETER	CONDITIONS		LT1078AC/LT1079AC			LT1078C/LT1079C LT1078S8/LT1079SW			UNITS	
				MIN	TYP	MAX	MIN	TYP	MAX		
$V_{OS}$	Input Offset Voltage	LT1078S8 LT1079SW	●	70	330	90	460	μV			
			●						100	540	μV
			●								
$\frac{\Delta V_{OS}}{\Delta T}$	Input Offset Voltage Drift (Note 5)	LT1078S8 LT1079SW	●	0.5	1.8	0.6	2.5	μV/°C			
			●						0.7	3.8	μV/°C
			●								
$I_{OS}$	Input Offset Current		●	0.06	0.35	0.06	0.50	nA			
$I_B$	Input Bias Current		●	6	9	6	11	nA			
$A_{VOL}$	Large-Signal Voltage Gain	$V_O = \pm 10V, R_L = 5k$	●	300	1200	250	1200	V/mV			
CMRR	Common Mode Rejection Ratio	$V_{CM} = 13V, -15V$	●	97	112	94	112	dB			
PSRR	Power Supply Rejection Ratio	$V_S = 5V, 0V$ to $\pm 18V$	●	100	112	97	112	dB			
	Maximum Output Voltage Swing	$R_L = 5k$	●	$\pm 11.0$	$\pm 13.6$	$\pm 11.0$	$\pm 13.6$	V			
$I_S$	Supply Current per Amplifier		●	49	73	50	85	μA			

The ● denotes specifications which apply over the full operating temperature range.

**Note 1:** Typical parameters are defined as the 60% yield of parameter distributions of individual amplifiers, i.e., out of 100 LT1079s (or 100 LT1078s) typically 240 op amps (or 120) will be better than the indicated specification.

**Note 2:** This parameter is tested on a sample basis only. All noise parameters are tested with  $V_S = \pm 2.5V, V_O = 0V$ .

**Note 3:** This parameter is guaranteed by design and is not tested.

**Note 4:** Power supply rejection ratio is measured at the minimum supply voltage. The op amps actually work at 1.8V supply but with a typical offset skew of  $-300\mu V$ .

**Note 5:** This parameter is not 100% tested.

# TYPICAL PERFORMANCE CHARACTERISTICS

Supply Current vs Temperature

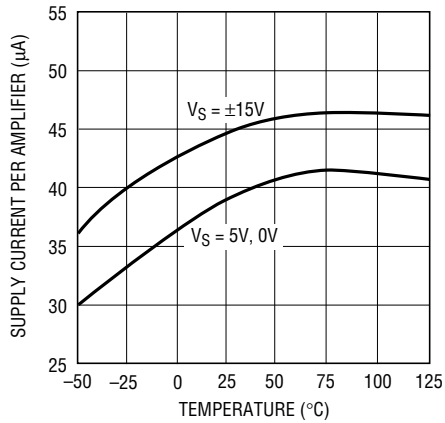

LT1078/79 • TPC01

Input Bias and Offset Currents vs Temperature

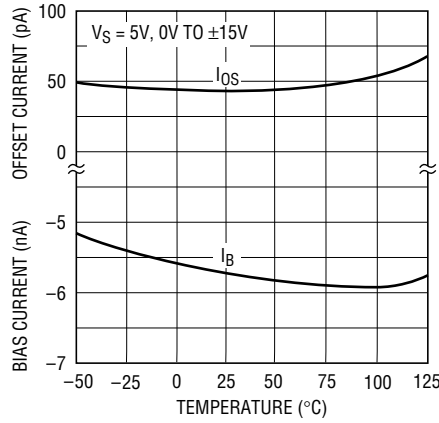

LT1078/79 • TPC02

Input Bias Current vs Common Mode Voltage

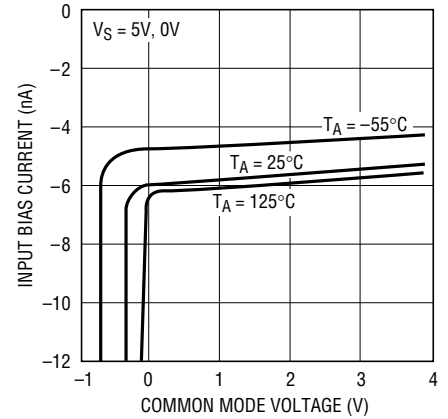

LT1078/79 • TPC03

0.1Hz to 10Hz Noise

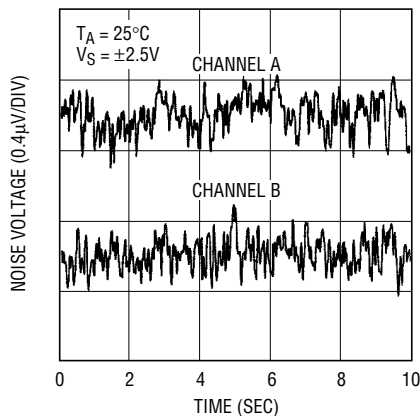

LT1078/79 • TPC04

0.01Hz to 10Hz Noise

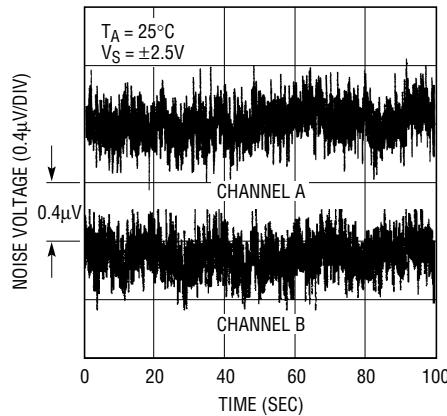

LT1078/79 • TPC05

Noise Spectrum

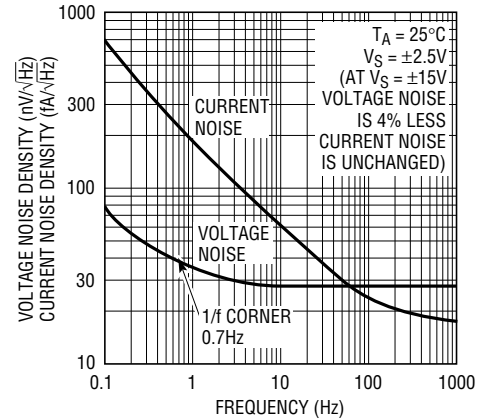

LT1078/79 • TPC06

10Hz Voltage Noise Distribution

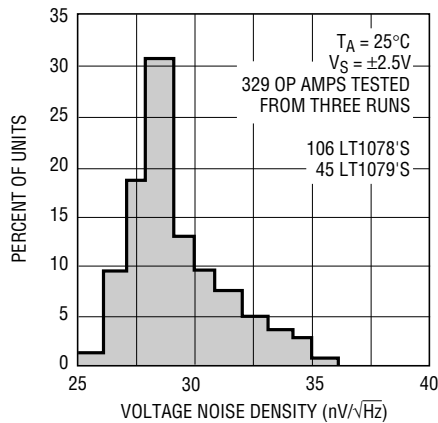

LT1078/79 • TPC07

Distribution of Offset Voltage Drift with Temperature (In All Packages Except Surface Mount)

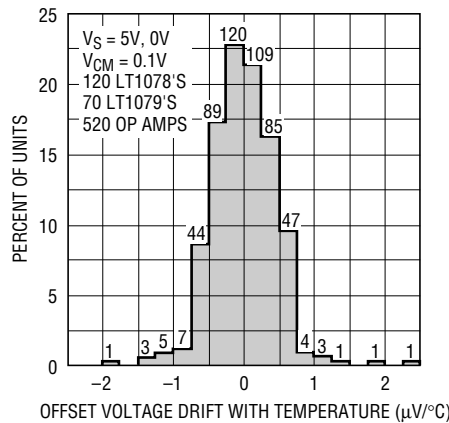

LT1078/79 • TPC08

Long Term Stability of Two Representative Units (LT1078)

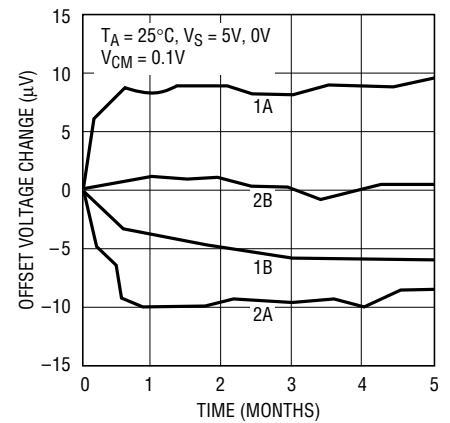

LT1078/79 • TPC09

# TYPICAL PERFORMANCE CHARACTERISTICS

Voltage Gain vs Frequency

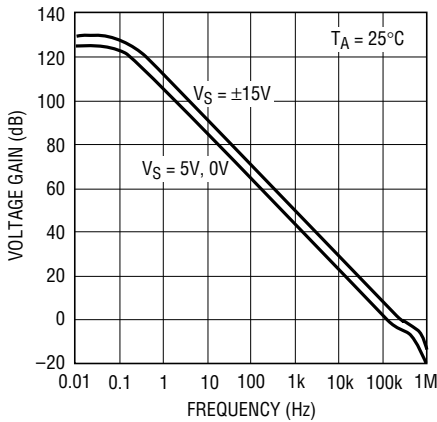

LT1078/79 • TPC10

Gain, Phase vs Frequency

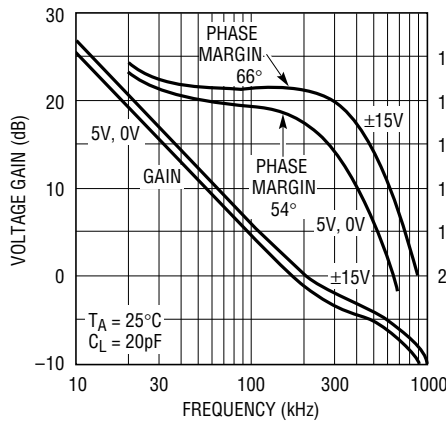

LTC1078/79 TPC11

Capacitive Load Handling

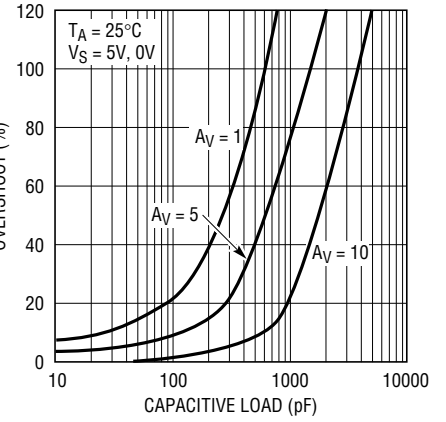

LT1078/79 • TPC12

Slew Rate, Gain Bandwidth Product and Phase Margin vs Temperature

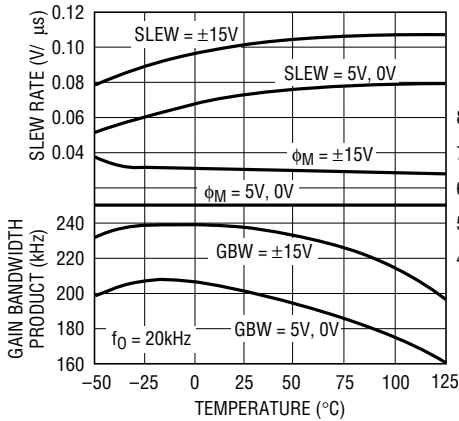

LT1078/79 • TPC13

Large-Signal Transient Response VS = 5V, 0V

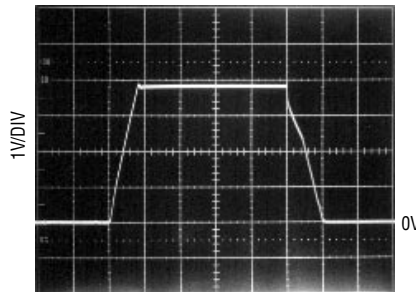

AV = 1, NO LOAD  
INPUT PULSE 0V TO 3.8V

LT1078/79 • TPC27

Large-Signal Transient Response VS = ±15V

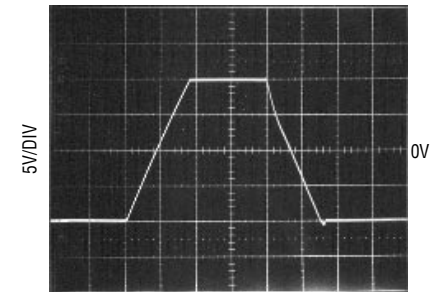

AV = 1  
NO LOAD

LT1078/79 • TPC28

Minimum Supply Voltage

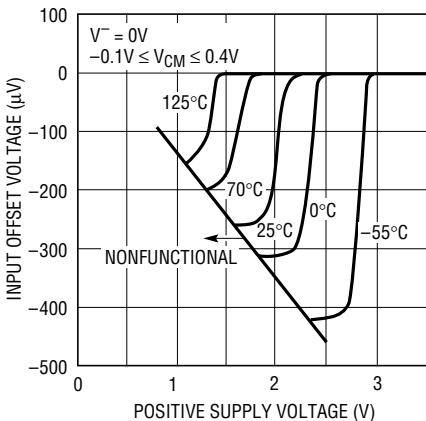

LT1078/79 • TPC16

Warm-Up Drift

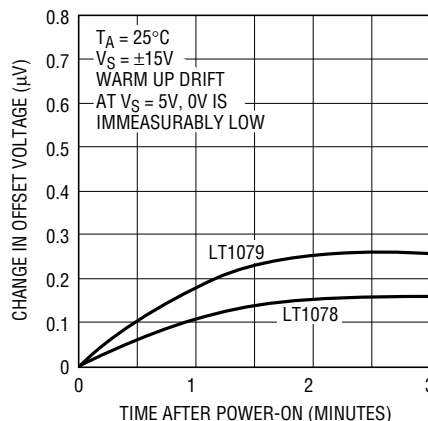

LT1078/79 • TPC17

Voltage Gain vs Load Resistance

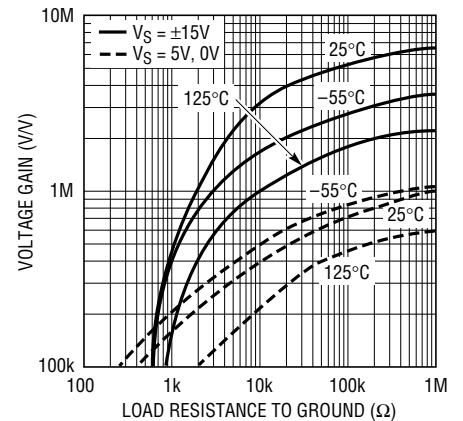

LT1078/79 • TPC18



# TYPICAL PERFORMANCE CHARACTERISTICS

**Output Saturation vs Temperature vs Sink Current**

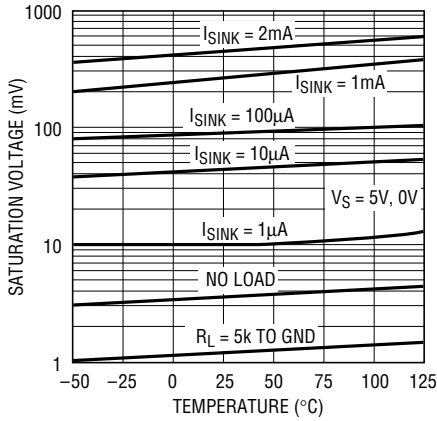

LT1078/79 • TPC19

**Output Voltage Swing vs Load Current**

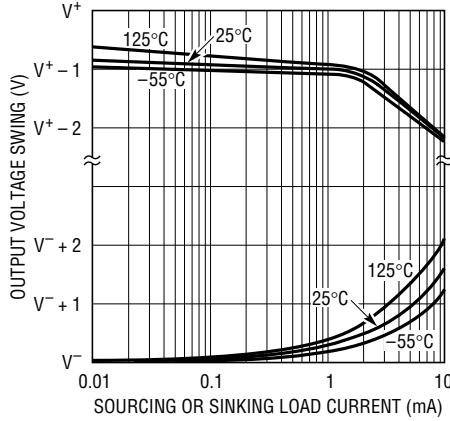

LT1078/79 • TPC20

**Distribution of Input Offset Voltage (LT1078 in 8-Pin SO Package)**

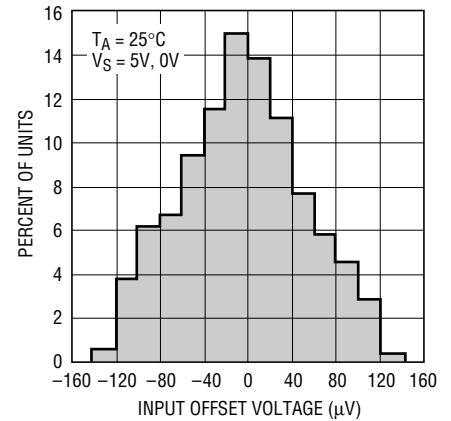

LT1078/79 • TPC21

**Common Mode Range vs Temperature**

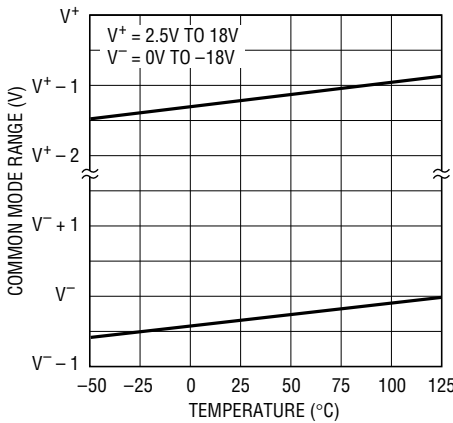

LT1078/79 • TPC22

**Undistorted Output Swing vs Frequency**

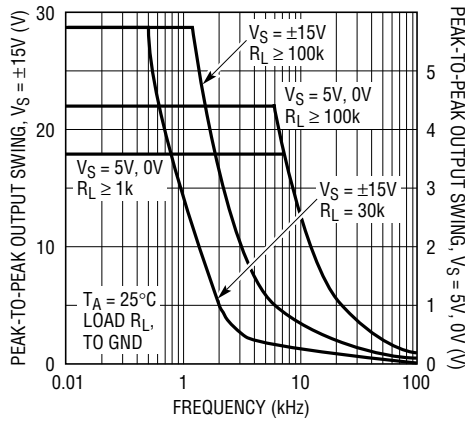

LT1078/79 • TPC23

**Closed Loop Output Impedance**

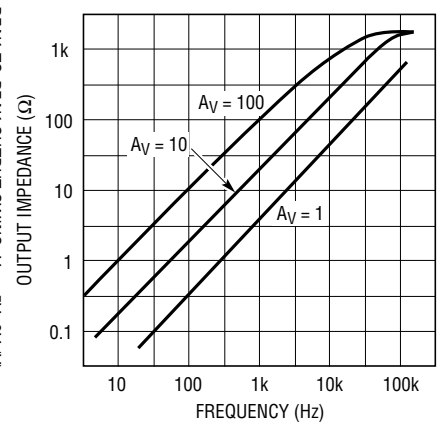

LT1078/79 • TPC24

**Common Mode Rejection Ratio vs Frequency**

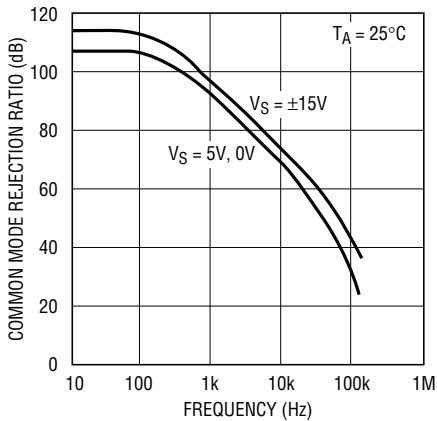

LT1078/79 • TPC25

**Power Supply Rejection Ratio vs Frequency**

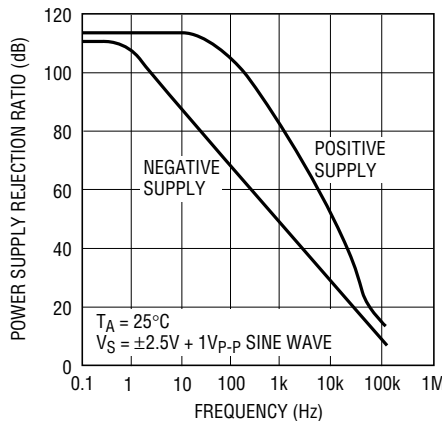

LT1078/79 • TPC26

**Channel Separation vs Frequency**

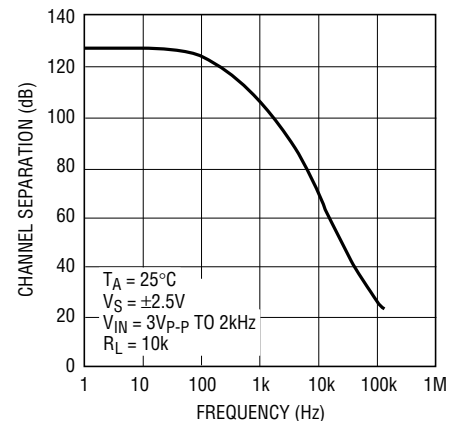

LT1078/79 • TPC27

## TYPICAL PERFORMANCE CHARACTERISTICS

**Small-Signal Transient Response**  
 $V_S = 5V, 0V$

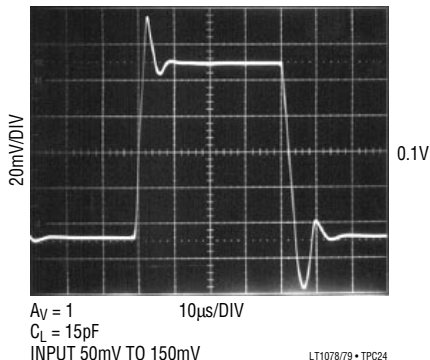

**Small-Signal Transient Response**  
 $V_S = \pm 2.5V$

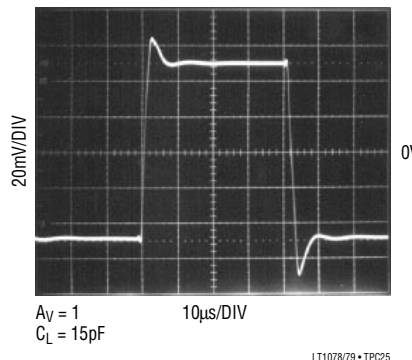

**Small-Signal Transient Response**  
 $V_S = \pm 15V$

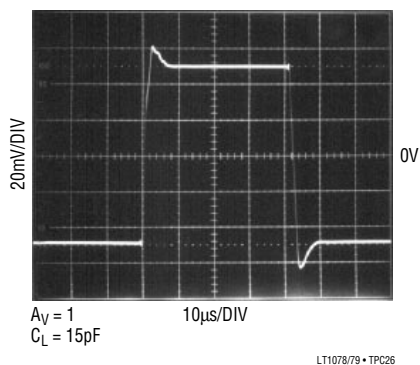

## APPLICATIONS INFORMATION

The LT1078/LT1079 devices are fully specified with  $V^+ = 5V$ ,  $V^- = 0V$ ,  $V_{CM} = 0.1V$ . This set of operating conditions appears to be the most representative for battery-powered micropower circuits. Offset voltage is internally trimmed to a minimum value at these supply voltages. When 9V or 3V batteries or  $\pm 2.5V$  dual supplies are used, bias and offset current changes will be minimal. Offset voltage changes will be just a few microvolts as given by the PSRR and CMRR specifications. For example, if  $PSRR = 114dB (= 2\mu V/V)$ , at 9V the offset voltage change will be  $8\mu V$ . Similarly,  $V_S = \pm 2.5V$ ,  $V_{CM} = 0V$  is equivalent to a common mode voltage change of 2.4V or a  $V_{OS}$  change of  $7\mu V$  if  $CMRR = 110dB (3\mu V/V)$ .

A full set of specifications is also provided at  $\pm 15V$  supply voltages for comparison with other devices and for completeness.

### Single Supply Operation

The LT1078/LT1079 are fully specified for single supply operation, i.e., when the negative supply is 0V. Input common mode range goes below ground and the output swings within a few millivolts of ground while sinking current. All competing micropower op amps either cannot swing to within 600mV of ground (OP-20, OP-220, OP-420) or need a pull-down resistor connected to the output to swing to ground (OP-90, OP-290, OP-490, HA5141/42/44). This

## APPLICATIONS INFORMATION

difference is critical because in many applications these competing devices cannot be operated as micropower op amps and swing to ground simultaneously.

As an example, consider the instrumentation amplifier shown on the front page. When the common mode signal is low and the output is high, amplifier A has to sink current. When the common mode signal is high and the output low, amplifier B has to sink current. The competing devices require a 12k pull-down resistor at the output of amplifier A and a 15k at the output of B to handle the specified signals. (The LT1078 does not need pull-down resistors.) When the common mode input is high and the output is high these pull-down resistors draw 300 $\mu$ A (150 $\mu$ A each), which is excessive for micropower applications.

The instrumentation amplifier is by no means the only application requiring current sinking capability. In seven of the nine single supply applications shown in this data sheet the op amps have to be able to sink current. In two of the applications the first amplifier has to sink only the 6nA input bias current of the second op amp. The competing devices, however, cannot even sink 6nA without a pull-down resistor

Since the output of the LT1078/LT1079 cannot go exactly to ground, but can only approach ground to within a few millivolts, care should be exercised to ensure that the output is not saturated. For example, a 1mV input signal will cause the amplifier to set up in its linear region in the gain 100 configuration shown in Figure 1a, but is not

enough to make the amplifier function properly in the voltage follower mode, Figure 1b.

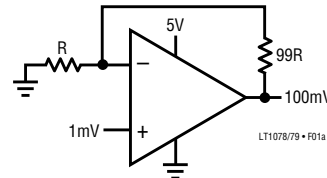

Figure 1a. Gain 100 Amplifier

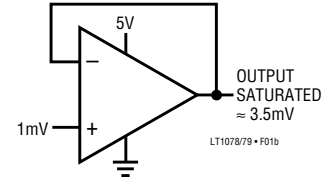

Figure 1b. Voltage Follower

Single supply operation can also create difficulties at the input. The driving signal can fall below 0V — inadvertently or on a transient basis. If the input is more than a few hundred millivolts below ground, two distinct problems can occur on previous single supply designs, such as the LM124, LM158, OP-20, OP-21, OP-220, OP-221, OP-420 (1 and 2), OP-90/290/490 (2 only):

1. When the input is more than a diode drop below ground, unlimited current will flow from the substrate ( $V^-$  terminal) to the input. This can destroy the unit. On the LT1078/LT1079, resistors in series with the input protect the devices even when the input is 5V below ground.
2. When the input is more than 400mV below ground (at 25°C), the input stage saturates and phase reversal occurs at the output. This can cause lockup in servo systems. Due to a unique phase reversal protection circuitry, the LT1078/LT1079 output does not reverse, as illustrated in Figure 2, even when the inputs are at  $-1V$ .

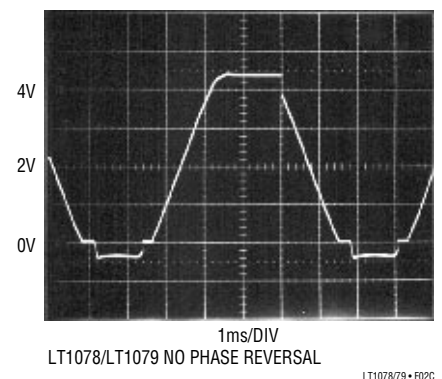
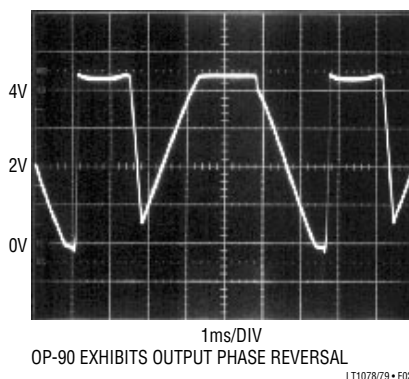
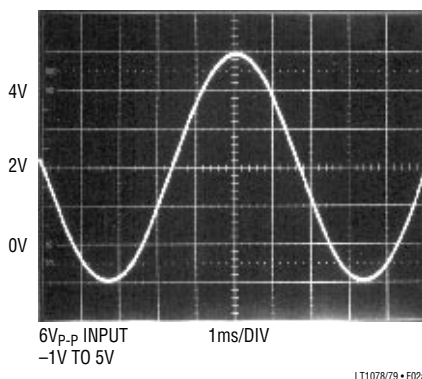

Figure 2. Voltage Follower with Input Exceeding the Negative Common Mode Range ( $V_S = 5V, 0V$ )

## APPLICATIONS INFORMATION

### Matching Specifications

In many applications the performance of a system depends on the matching between two op amps, rather than the individual characteristics of the two devices. The two and three op amp instrumentation amplifier configurations shown in this data sheet are examples. Matching characteristics are not 100% tested on the LT1078/LT1079.

Some specifications are guaranteed by definition. For example, 70 $\mu$ V maximum offset voltage implies that mismatch cannot be more than 140 $\mu$ V. 97dB (= 14 $\mu$ V/V) CMRR means that worst-case CMRR match is 91dB (= 28 $\mu$ V/V). However, Table 1 can be used to estimate the expected matching performance at  $V_S = 5V, 0V$  between the two sides of the LT1078, and between amplifiers A and D, and between amplifiers B and C of the LT1079.

Table 1

PARAMETER		LT1078AC/LT1079AC/LT1078AM/LT1079AM		LT1078C/LT1079C/LT1078M/LT1079M		UNITS
		50% YIELD	98% YIELD	50% YIELD	98% YIELD	
$V_{OS}$ Match, $\Delta V_{OS}$	LT1078	30	110	50	190	$\mu$ V
	LT1079	40	150	50	250	$\mu$ V
Temperature Coefficient $\Delta V_{OS}$		0.5	1.2	0.6	1.8	$\mu$ V/ $^{\circ}$ C
Average Noninverting $I_B$		6	8	6	10	nA
Match of Noninverting $I_B$		0.12	0.4	0.15	0.5	nA
CMRR Match		120	100	117	97	dB
PSRR Match		117	105	117	102	dB

### Comparator Applications

The single supply operation of the LT1078/LT1079 and its ability to swing close to ground while sinking current

lends itself to use as a precision comparator with TTL compatible output.

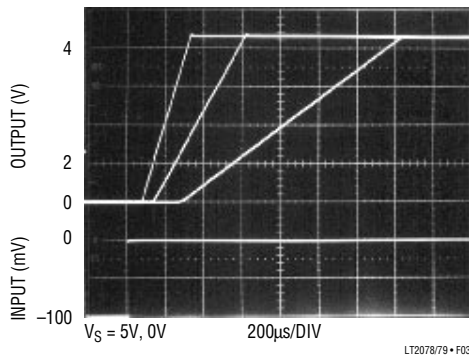

Figure 3. Comparator Rise Response Time to 10mV, 5mV, 2mV Overdrives

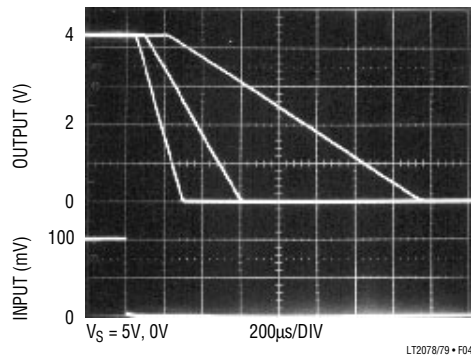
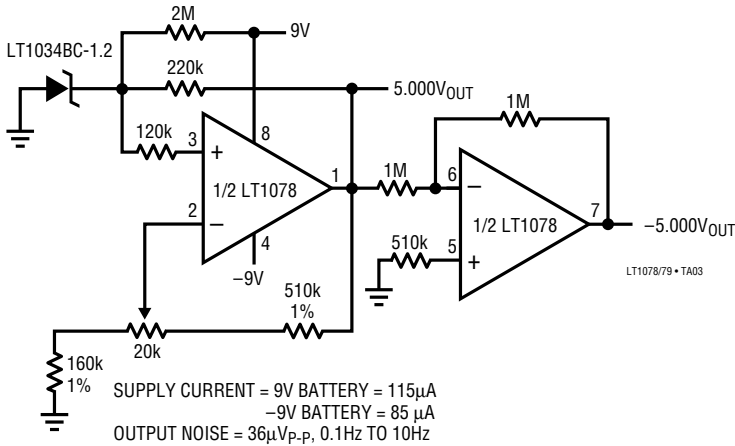

Figure 4. Comparator Fall Response Time to 10mV, 5mV, 2mV Overdrives

# TYPICAL APPLICATIONS

**Micropower, 10ppm/°C, ±5V Reference**



THE LT1078 CONTRIBUTES LESS THAN 3% OF THE TOTAL OUTPUT NOISE AND DRIFT WITH TIME AND TEMPERATURE. THE ACCURACY OF THE -5V OUTPUT DEPENDS ON THE MATCHING OF THE TWO 1M RESISTORS

**Gain of 10 Difference Amplifier**

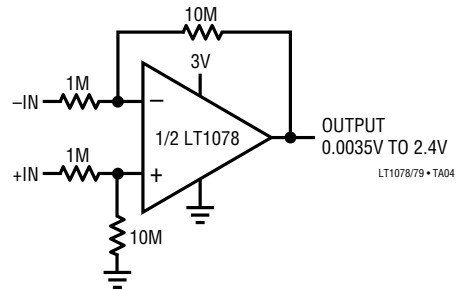

BANDWIDTH= 20kHz  
 OUTPUT OFFSET= 0.7mV  
 OUTPUT NOISE= 80 µV<sub>p-p</sub> (0.1Hz TO 10Hz)  
 260 µV<sub>RMS</sub> OVER FULL BANDWIDTH

THE USEFULNESS OF DIFFERENCE AMPLIFIERS IS LIMITED BY THE FACT THAT THE INPUT RESISTANCE IS EQUAL TO THE SOURCE RESISTANCE. THE PICOAMPERE OFFSET CURRENT AND LOW CURRENT NOISE OF THE LT1078 ALLOWS THE USE OF 1M SOURCE RESISTORS WITHOUT DEGRADATION IN PERFORMANCE. IN ADDITION, WITH MEGOHM RESISTORS MICROPOWER OPERATION CAN BE MAINTAINED

**Picoampere Input Current, Triple Op Amp Instrumentation Amplifier with Bias Current Cancellation**

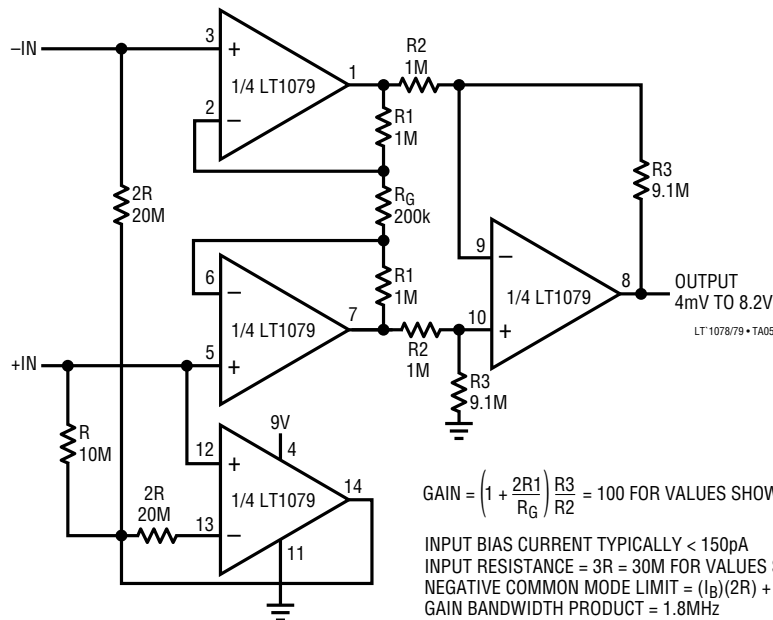

# TYPICAL APPLICATIONS

**85V, -100V Common Mode Range Instrumentation Amplifier ( $A_V = 10$ )**

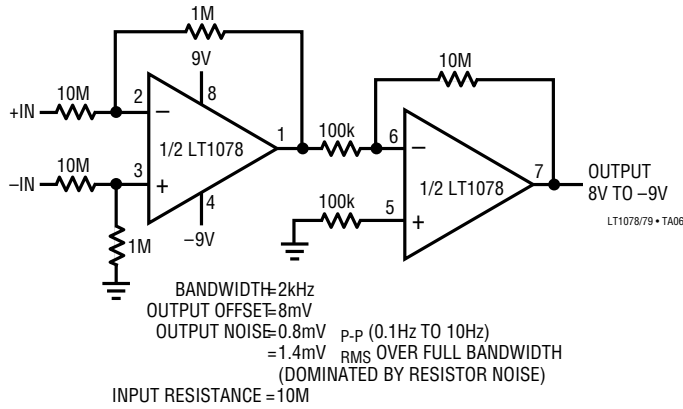

**Half-Wave Rectifier**

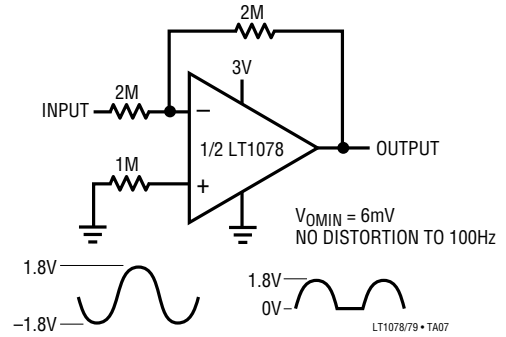

**Absolute Value Circuit (Full-Wave Rectifier)**

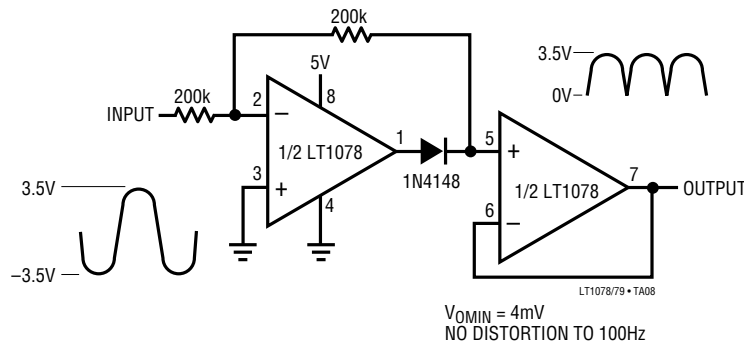

**Programmable Gain Amplifier (Single Supply)**

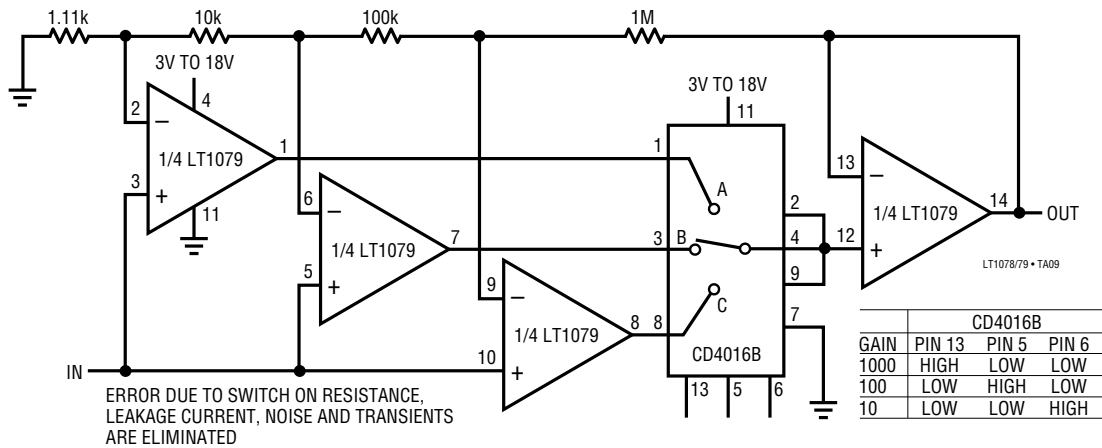

TYPICAL APPLICATIONS

Single Supply, Micropower, Second Order Lowpass Filter with 60Hz Notch

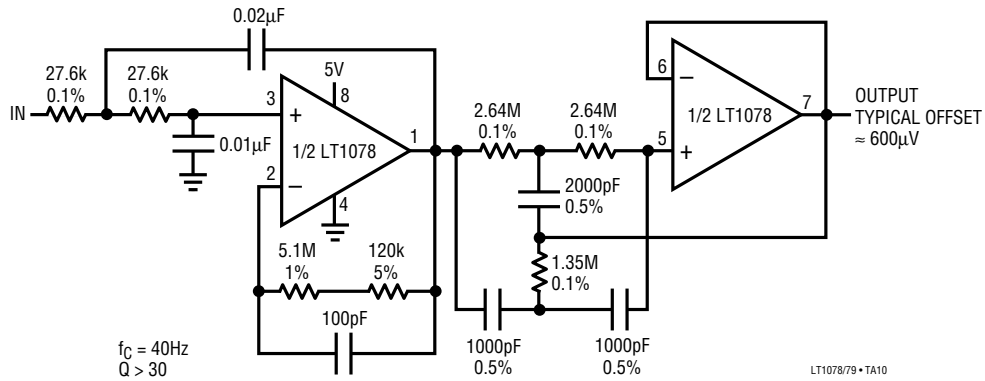

Micropower Multiplier/Divider

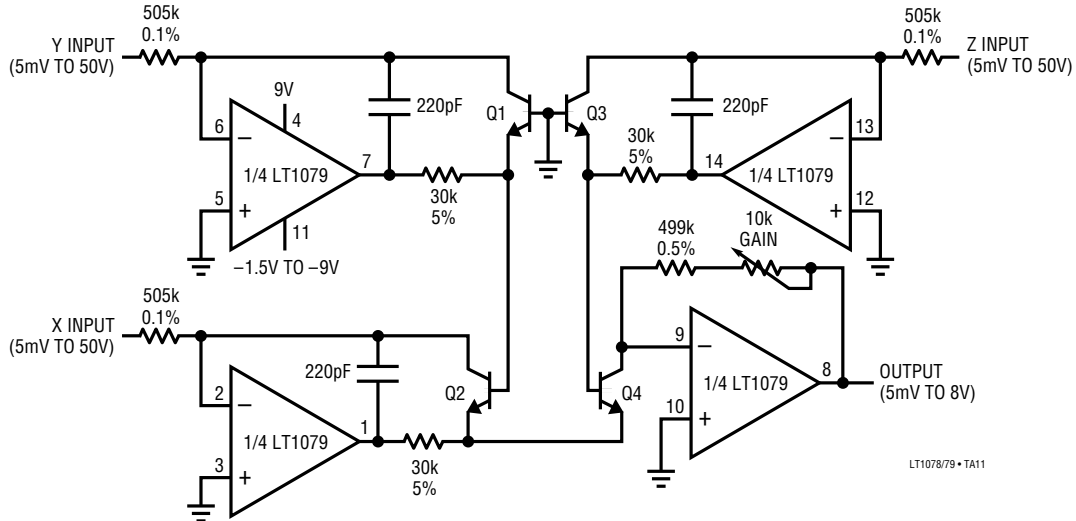

Q1, Q2, Q3, Q4 = MAT-04  
TYPICAL LINEARITY = 0.01% OF FULL-SCALE OUTPUT  
OUTPUT =  $\frac{(X)(Y)}{(Z)}$ , POSITIVE INPUTS ONLY  
NEGATIVE SUPPLY CURRENT =  $165\mu\text{A} + \frac{X + Y + Z + \text{OUT}}{500\text{k}}$   
POSITIVE SUPPLY CURRENT =  $165\mu\text{A} + \frac{\text{OUT}}{500\text{k}}$   
BANDWIDTH (< 3V<sub>p-p</sub> SIGNAL): X AND Y INPUTS = 10kHz  
Z INPUT = 4kHz

TYPICAL APPLICATIONS

Micropower Dead Zone Generator

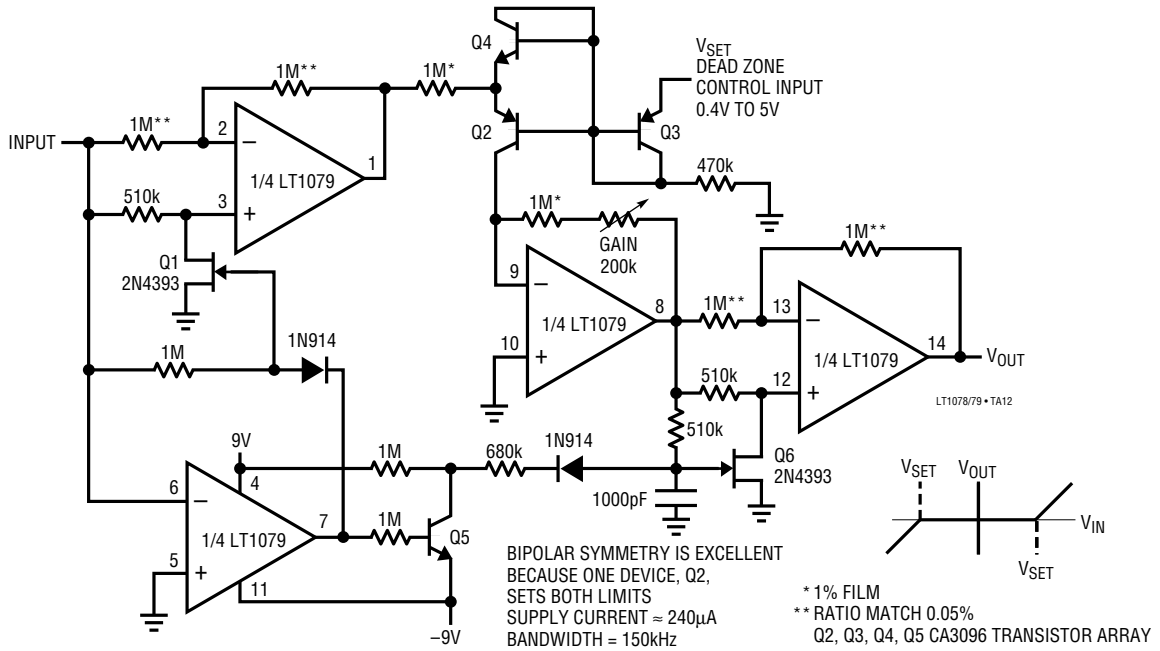



TYPICAL APPLICATIONS

Lead-Acid Low-Battery Detector with System Shutdown

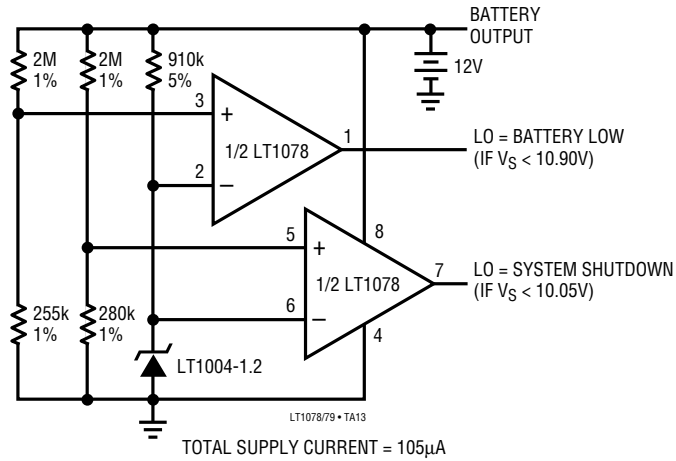

Platinum RTD Signal Conditioner with Curvature Correction

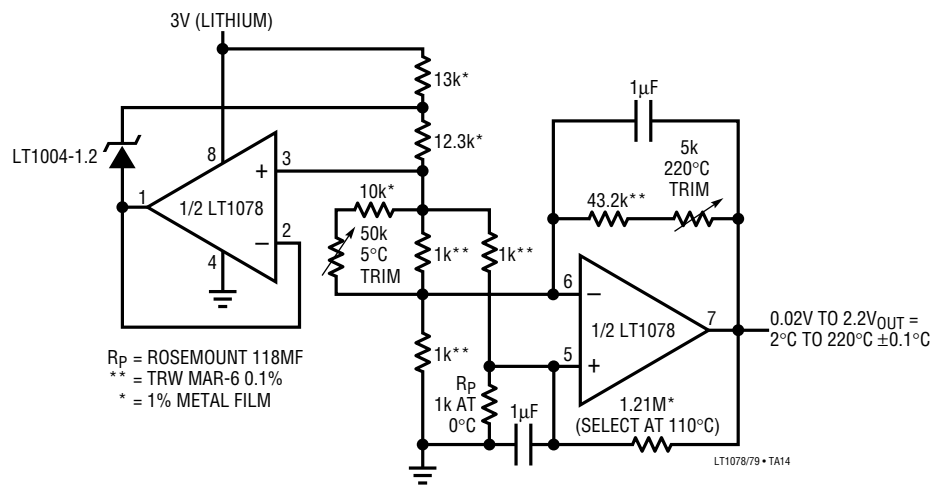

SIMPLIFIED SCHEMATIC

1/2 LT1078, 1/4 LT1079

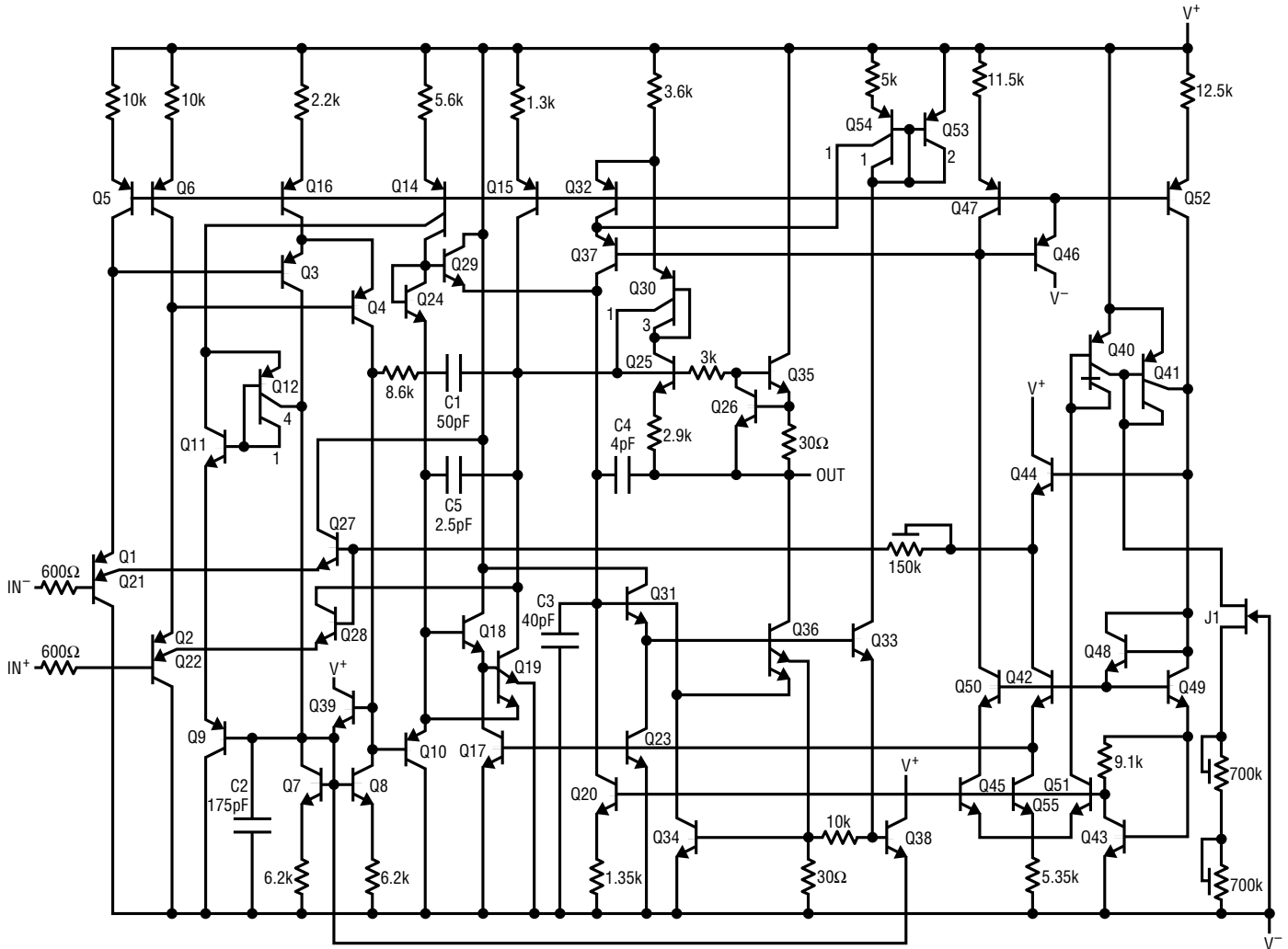

LT1078/79 • SIMPLIFIED SCHEM

**PACKAGE DESCRIPTION** Dimensions in inches (millimeters) unless otherwise noted.

**H Package**  
**8-Lead TO-5 Metal Can (0.230 PCD)**  
 (LTC DWG # 05-08-1321)

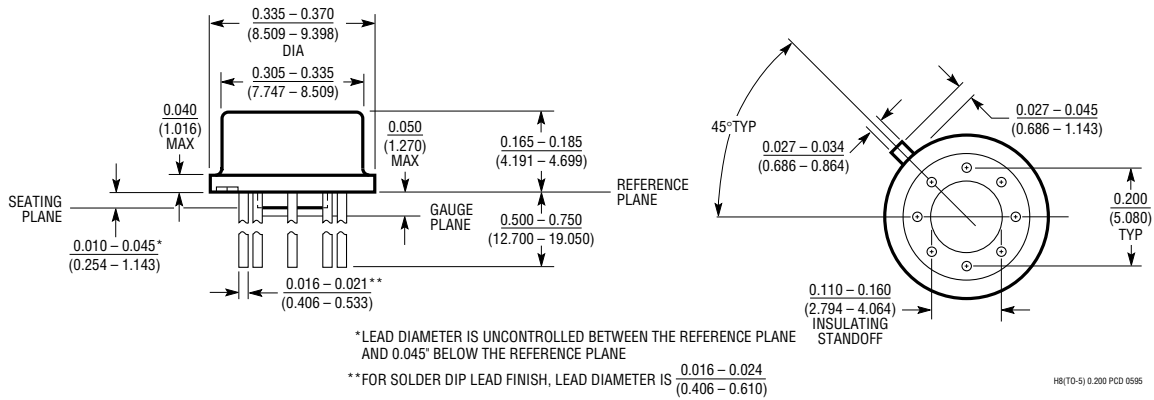

**J8 Package**  
**8-Lead CERDIP (Narrow 0.300, Hermetic)**  
 (LTC DWG # 05-08-1110)

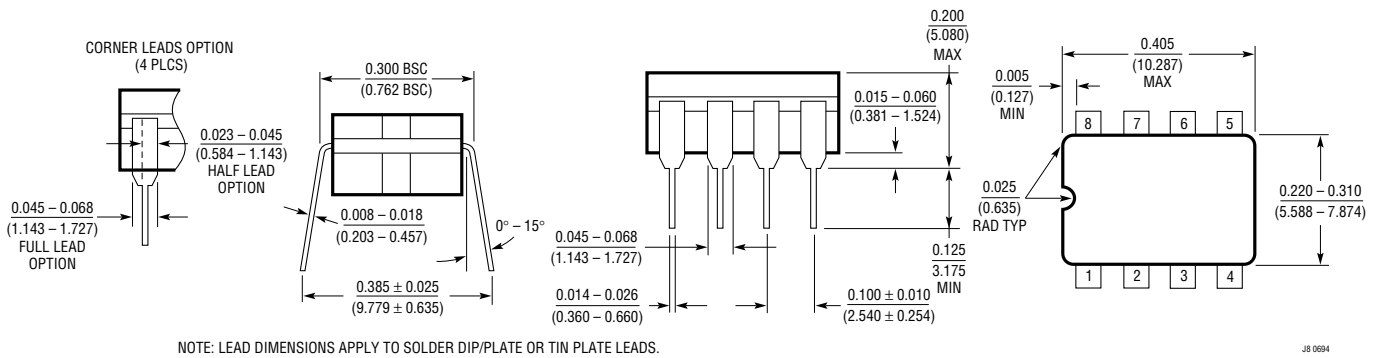

**J Package**  
**14-Lead CERDIP (Narrow 0.300, Hermetic)**  
 (LTC DWG # 05-08-1110)

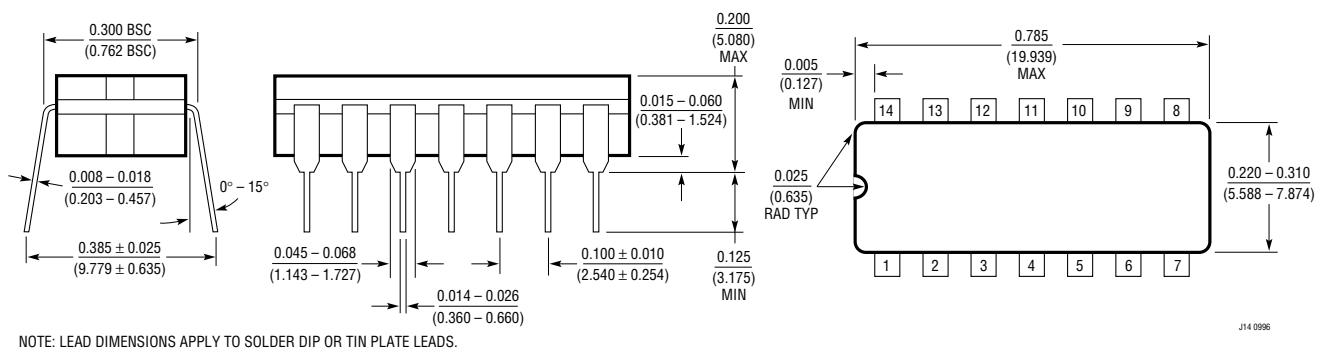

**PACKAGE DESCRIPTION** Dimensions in inches (millimeters) unless otherwise noted.

**N8 Package**  
**8-Lead PDIP (Narrow 0.300)**  
 (LTC DWG # 05-08-1510)

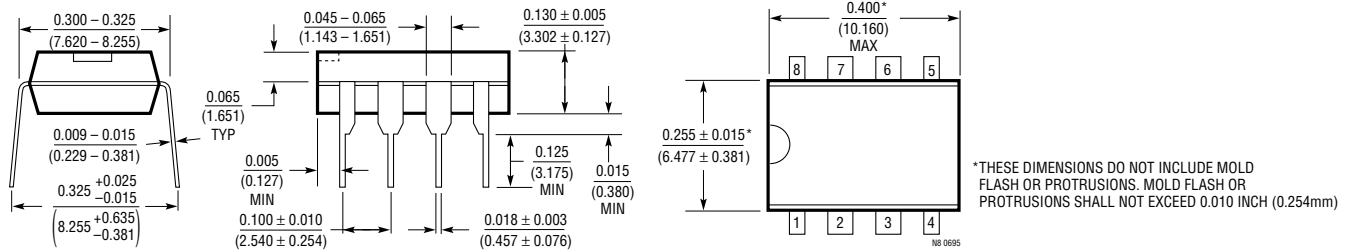

**N Package**  
**14-Lead PDIP (Narrow 0.300)**  
 (LTC DWG # 05-08-1510)

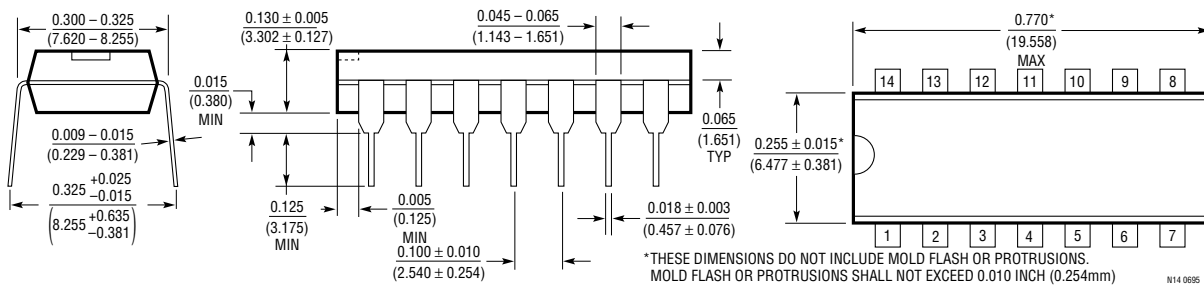

**S8 Package**  
**8-Lead Plastic Small Outline (Narrow 0.150)**  
 (LTC DWG # 05-08-1610)

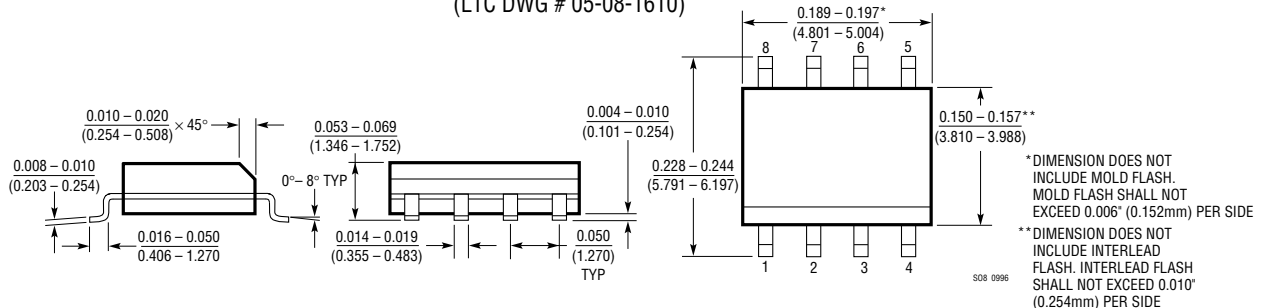

**SW Package**  
**16-Lead Plastic Small Outline (Wide 0.300)**  
 (LTC DWG # 05-08-1620)

