

*Advance Information*

# Solid State Relay for Automotive Flasher Applications

This device is a Dual High Side Power Switch dedicated for automotive flasher applications. In comparison with mechanical solutions, this device offers higher reliability as well as protection and diagnostic features.

The device consists of two 25mΩ Rdson fully protected high side switches, in a surface mount power package. It interfaces directly with a microcontroller and includes a current recopy function in order to allow the detection of a failed lamp in the application.

- Designed for Automotive Flasher Applications
- Junction Temperature Range from - 40°C to 150°C
- Operating Voltage Range from 8V to 35V
- Maximum Breakdown Voltage greater than 40V
- Protected in case of loss of ground
- Surface Mount Power Package
- 25mΩ Rdson per Channel at 25°C
- 8Amps Nominal Current per Channel
- 1.2W Warning Lamp Driver
- Overtemperature Protection with Hysteresis
- Open Load Detection in On-State
- Short-Circuit Protection
- Overload Current Protection
- Current Recopy to Monitor Lamp Output Current
- Under Voltage Shutdown
- ESD Protection 2kV
- Standby Current less than 10μA at V<sub>bat</sub> less than 14V

## MC33288

### SOLID STATE RELAY FOR AUTOMOTIVE FLASHER APPLICATIONS

SEMICONDUCTOR  
TECHNICAL DATA



**DH SUFFIX**  
HSOP20 Package  
CASE 979-04

#### PIN ASSIGNMENT

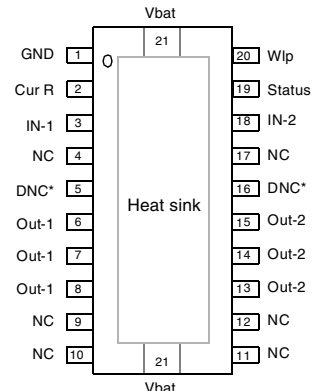

\* Do Not Connect

#### ORDERING INFORMATION

Device	Operating Temperature Range	Package
MC33288DH	TA=-40° to +125°C	HSOP20
MC33288DHR2	TA=-40° to +125°C	HSOP20

#### Simplified Application Schematic

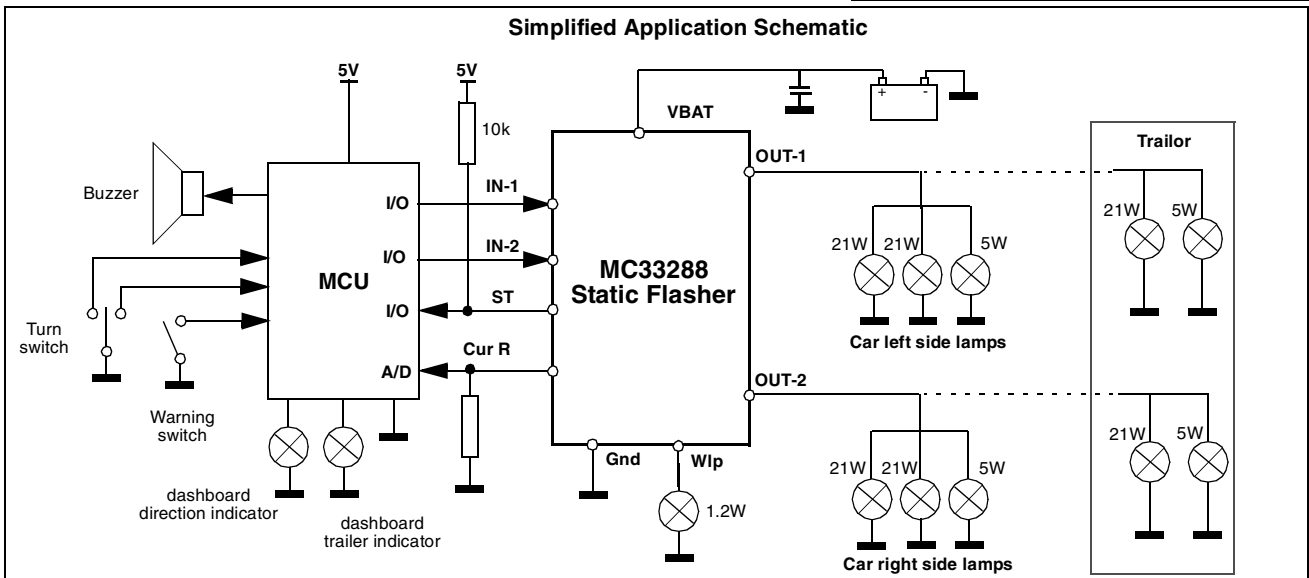

This document contains information on a new product. Specifications and information herein are subject to change without notice.

## PINS FUNCTION DESCRIPTION

Pin No.	Name/Function	Description
TAB	V <sub>bat</sub> Supply Voltage	The backside TAB is connected to the power supply of the MC33288DH. In addition to its supply function, this pin contributes to the thermal behaviour of the device by conducting the heat from the switching MOSFET to the printed circuit board.
6,7,8 13,14,15	OUT1 OUTPUT Channel 1 OUT 2 OUTPUT Channel 2	Pins 6,7,8 are the source of the output1 25mOhm MOSFET1. Pins 13,14,15 are source of the output 2 25mOhm MOSFET2. They deliver current to the connected loads and are respectively controlled via the IN1 and IN2 pins. These outputs are current limited and thermally protected.
3 18	IN 1 INPUT Channel 1 IN 2 INPUT Channel 2	These are the device input pins which directly control their associated outputs. The levels are CMOS compatible. When the input is a logic low, the associated output MOSFET is in the off state. When input is high, the MOSFET is turned on and the load is activated. When both inputs are low, the device is in standby mode and its supply current is reduced. Each input pin has an internal active pull down, so that it will not float if disconnected.
19	Status Status for both Channels	The Fault output is an open drain indication that goes active low when a fault mode (Openload, Overtemp) is detected by the device on either one channel or both simultaneously. Its internal structure is an open drain architecture with an internal clamp at 6V. An external pull up resistor connected to V <sub>dd</sub> (5V) is needed. See Functional Truth Table.
20	Wlp Warning Lamp Output	This pin is the source of a 3.2 Ohm MOSFET. This output is current limited and thermally protected. It delivers current through the connected load when both IN1 and IN2 inputs are logic high. It is usually used as a warning lamp driver for Flasher application.
2	Cur R Load Current Sense	The Current Sense pin deliver a ratioed amount (1/1000) of the sum of the currents that can be used to generate signal ground referenced output voltages for use by the microcontroller.
4, 9, 10, 11, 12, 17	NC Not Connected	These pins are not used.
5, 16	DNC Do Not Connect	These pins must not be connected.
11	GND GROUND	This is the Ground pin of the device.



**MAXIMUM RATINGS**

Ratings	Symbol	Value	Unit
---------	--------	-------	------

**ELECTRICAL RATINGS**

Vbat Voltage with Respect to Gnd : Continuous/Pulse	Vbat	-14 to + 40	V
Out-1 & Out-2 Voltage with Respect of Gnd : Continuous/Pulse	Vout	-0.3 to 40	V
Out-1 to Vbat & Out-2 to Vbat voltage : Continuous/Pulse	Vout	40	V
IN-1, IN-2, St DC Voltage : Continuous/Pulse	Vin	-0.3 to 7	V
Cur R Voltage : Continuous/Pulse	Vcr	-0.3 to 7	V
ESD all Pins Human Body Model (note1) Machine Model (note2)	V <sub>esd1</sub> V <sub>esd2</sub>	+/-2000 +/-200	V V
Out-1, Out-2 Output Current : Pulse (note 3)	I <sub>outp</sub>	40	Amp
IN-1, IN-2, St	I <sub>lin</sub>	+/-5	mA

**THERMAL RATINGS**

Junction Temperature	T <sub>j</sub>	- 40 to 150	°C
Storage Temperature Range	T <sub>st</sub>	- 65 to +150	°C
Thermal Resistance Junction to Case	R <sub>thjc</sub>	2	°C/W
Thermal Resistance Junction to Ambient (note 4)	R <sub>thja</sub>	25	°C/W
Power Dissipation at T <sub>case</sub> 140°C (note 5)	P <sub>d</sub>	5	W

**NOTES :**

- EDS1 testing is performed in accordance with the Human Body Model (C<sub>zap</sub> = 100pF, R<sub>zap</sub> = 1500Ω)
- EDS2 testing is performed in accordance with the Machine Model (C<sub>zap</sub> = 100pF, R<sub>zap</sub> = 0Ω)
- During lamp inrush current.
- Device mounted on dual side printed circuit board with 70μm copper thickness and 10cm<sup>2</sup> copper heat sink (2.5 cm<sup>2</sup> on top side and 7.5 cm<sup>2</sup> on down side).
- Assuming a 150°C maximum junction temperature.

**ELECTRICAL CHARACTERISTICS** (Vbat from 9 to 16V and junction temperature T<sub>j</sub> from -40° to 150°C, unless otherwise noted)

Description	Symbol	Characteristics			Unit	Conditions
		min.	typ.	max.		
Nominal Operating Voltage	V <sub>bat</sub>	9		16	V	
Functional Operating Voltage	V <sub>bat</sub>	8		35	V	
Under Voltage Threshold	V <sub>uv</sub>	6	7	8	V	
Vbat Standby Supply Current	I <sub>stdby</sub>		1	10	μA	V <sub>bat</sub> < 14V & V <sub>in</sub> = 0V, T <sub>j</sub> < 125°C
Supply Current in On State	I <sub>on</sub>		8	20	mA	IN-1 & IN-2 @ 3.5V, no fault, V <sub>bat</sub> < 14V, T <sub>j</sub> < 125°C
Drain to Source on Resistance	R <sub>dson</sub>		20	25	mΩ	I <sub>out</sub> = 4A, V <sub>bat</sub> > 9V & T <sub>j</sub> = 25°C
Drain to Source on Resistance	R <sub>dson</sub>		30	40	mΩ	I <sub>out</sub> = 4A, V <sub>bat</sub> > 9 & T <sub>j</sub> = 150°C
High Current Limitation	I <sub>lim</sub>		30		A	V <sub>out</sub> > 1V
Short Circuit limitation	I <sub>lim</sub>		4		A	V <sub>out</sub> < 1V, T <sub>j</sub> = 25°C
Hot Openload Threshold	I <sub>ol</sub>		1		A	
Vbat to Output Breakdown Voltage	V <sub>dss</sub>	40			V	In-1 and In-2 @ 0V, V <sub>out</sub> = 0, I <sub>out</sub> = -0.25mA
Vbat to Out-1 : Leakage Current	I <sub>out-leak</sub>			10	μA	V <sub>in-1</sub> = 0V, V <sub>bat</sub> = 35V, V <sub>out-1</sub> = 0V

## MC33288

Description	Symbol	Characteristics			Unit	Conditions
		min.	typ.	max.		
Vbat to Out-2 : Leakage Current	$I_{out-leak}$			10	$\mu A$	Vin-2 =0V, Vbat =35V, Vout-2=0V
Vin-1, Vin-2 : Input Voltage Low Threshold	$V_{il}$			1.5	V	
Vin-1, Vin-2 : Input Voltage High Threshold	$V_{ih}$	3.5			V	
Vin-1, Vin-2 : Input Voltage Hysteresis	$V_{ih}$	0.4	0.7	0.9	V	
Vin-1, Vin-2 : Input Current	$I_{in}$		18	40	$\mu A$	Vin-1, Vin-2 = 3.5V
Status Output Voltage	$V_{st}$			0.5	V	Ist = 1 mA; Output in Fault
Thermal Shutdown	$T_{shut}$	150			$^{\circ}C$	
Thermal Shutdown Hysteresis	$T_{hyst}$		10		$^{\circ}C$	
Current Recopy Ratio	$C_r$		1/1000			Vout>Vbat -1V, Iout from 2A to 4A Tj -40°C to 105°C, Vbat 9 to 16V
Current Recopy Ratio Accuracy	$C_{r-ac}$	-10		10	%	Vout >Vbat -1V, Iout from 2A to 4A Tj -40°C to 105°C, Vbat 9 to 16V
Extended Current Recopy Ratio	$C_{rex}$		1/1000			Vout >Vbat -1V, Iout from 1A to 8A
Extended Current Recopy Ratio Accuracy	$C_{rex-ac}$	-20		20	%	Vout >Vbat -1V, Iout from 1A to 8A
Current Recopy Clamp Voltage At 10mA	$V_{clst}$	5.5		7	V	
Nominal Flasher Frequency Operation	$F_{fl}$		1.5		Hz	
Frequency Operation	$F_{op}$			100	Hz	
Nominal Flasher Duty Cycle Operation	$DC_{fl}$		50		%	
Wlp output Drain to Source on Resistance	$R_{W_{on}}$			3.2	$\Omega$	Iout =100mA, Vbat > 9V & Tj = 25°C
Wlp output Drain to Source on Resistance	$R_{W_{on}}$			5	$\Omega$	Iout =100mA, Vbat > 9V & Tj = 125°C
Wlp output Current Limitation	$I_{W_{lim}}$		500		mA	Vout =0V
Wlp Thermal Shutdown	$T_{W_{shut}}$	150			$^{\circ}C$	
Maximum Output Positive Slew Rate	$T_r$	0.01	0.3	2	V/ $\mu s$	load = 6 $\Omega$
Maximum Output Negative Slew Rate	$T_f$	0.01	0.3	2	V/ $\mu s$	load = 6 $\Omega$
Turn On delay time	$T_{don}$	1	30	200	$\mu s$	load = 6 $\Omega$ , from Vin/2 to 10% Vout
Turn Off delay time	$T_{doff}$	1	40	200	$\mu s$	load = 6 $\Omega$ , from Vin/2 to 90% Vout

**DEVICE DESCRIPTION****Introduction**

The MC33288DH is a dual high side switch with appropriate control, protection, and diagnostic features dedicated to automotive flasher applications. The device consists of two independent 25mΩ power switches and an additional 3.2 Ohm high side switch capable of controlling a 1.2W warning lamp. It interfaces directly with a microcontroller and the package used is a HSOP20 power small outline, 20 pins. The MC33288 incorporates a status pin and a load current sense capability.

**Power Supply**

The MC33288 can be directly connected to the supply line. In standby mode (In-1 & In-2 @ OV), the supply current is less than 10μA for Vbat supply voltage below 14V. This feature allows a very low supply current on the battery when the car is idle or parked.

During off state, the current recopy pin and the status pins are in high impedance.

In case of loss of (digital) ground, the power MOSFETs turn off in order to safely tie the load current to zero.

**Nominal Voltage and Transient Operation**

The nominal operation voltage is from 9 to 16V. The MC33288 is functional over a larger voltage range from 8V to 35V. The technology used for both power and analog circuitry sustains 40V DC voltage.

**Reverse Battery**

The MC33288 is self protected against reverse battery up to -14 Volts in a continuous mode. When a negative battery voltage arises, the MOSFETs are internally turned off. The load current flows in the body diode of each MOSFET. The power dissipation within the MC33288DH is then  $V_f \times I_{load}$ , where  $I_{load}$  is the total current set by the loads and  $V_f$  is the forward body diode voltage.  $V_f$  is 0.5V typical at 150°C and decreases with temperature with a drop of -2mV/°C.

**Power Output Switches**

The device has two independent high side switches. Each switch is realised with an N-channel power MOSFET and includes current and temperature sensing circuitries. The MOSFET gates are driven by analog circuitry which includes charge pump and fault detection. A specific feature of this device is the output current recopy.

Each output has a 25mΩ  $R_{dson}$  max at 25°C. The  $R_{dson}$  value reaches 40mΩ at 150°C junction temperature. Each output has a parasitic drain to source diode, inherent to the technology. This diode can sustain as much current as the MOSFET. This diode is reversed biased during normal operation of the MOSFET and is forward biased during reverse battery or negative transient pulses.

The output MOSFET can each drive 8 Amps nominal. This maximum current condition occurs when up to three 21W lamps and two small 5 or 7W lamps are connected on each channel, at higher Vbat voltage specification. This is the case when a trailer is attached to the car. As the flasher can operate in warning or hazard operation mode with its two channels on, the MC33288 can drive 16 Amps total.

When lamps are turned on, the inrush current can reach up to 6 times the nominal lamp current. For this particular application, the total inrush current can reach 6 times 8 Amps, that is up to 48Amps per channel. The 48Amps value will only occur at the first lamp turn on. In order to optimise the total system, (MC33288, printed circuit board, wiring, fuse etc.) the

device incorporates a current limitation at 30 Amps typical. This means that the really first inrush current will be clamped at 30 Amps. The second lamp turn on of the flashing cycle will not see any clamping as the lamps have been heated up in the previous cycle.

In-1 and In-2 are the two inputs of the device, connected to a microcontroller I/O ; they are CMOS compatible. When these inputs are in low state, the device is in standby mode. When any of the inputs are switched to a high level, the associated output MOSFET is turned on.

**Status**

The device has a single status pins which reports an over temperature and an openload condition in the device. This pin is an open drain structure and needs an external pull up resistor. The device incorporates overtemperature sense on each output MOSFET in order to independently protect each output. But, the report of the overtemperature is done through one single status pin called Status, in order to minimise the number of I/O connection of the MCU.

**Open Load Function**

The open load detection is active during the ON phase (Hot open load detection). An amplifier measures the differential voltage between  $V_{bat}$  and  $V_{out}$ .

When the load current is below 1A, the open load circuitry will pull down the status output. If the open load condition is present before the device turn-on, the status will be pulled down after a delay due to the rise time of the output.

**Current Recopy Function**

Flasher application needs to detect failed lamp. The system must detect one 21W lamp failing, in the flasher application only, without a trailer. The MC33288 has an output current recopy function which recopies on the Cur R pin a portion of the output current. Each channel is connected to the same Cur R pin as the system have to operate in the flasher mode only and not in the warning operation.

The MC33288 provides a current recopy of 1/1000 of the main output current, either output left or right. The recopy function has its higher accuracy of +-10% in the usual operation range and an accuracy of +-20% in the total operating range. This allows a precise detection of one 21W lamp, but also the detection of additional lamps in case of trailer connection.

An external resistor must be connected to the Cur R pin and then tied to a microcontroller A/D input for analog voltage measurement. The Cur R pin is internally clamped to protect the MCU A/D input.

**Warning Lamp Driver**

The warning lamp driver is a 3.2 Ohms  $R_{dson}$  max High Side MOSFET to control the 1.2W dashboard warning lamp. This output is current limited and thermally protected/activated only in the warning mode. It is turned on by activation of both right and left inputs (IN1 and IN2)

**Package**

The device is assembled into a power surface mount package. This package offers high thermal performances and high current capabilities. It offers 10 pins on each package sides and an additional pin which is the package heat sink, called pin 21. The heat sink acts as the MC33288 power Vbat connection.

**Soldering Information**

This device is packaged in a Surface Mount Power package intended to be soldered directly on the Printed Circuit Board.

This device was qualified according to JEDEC standards JESD22-A113-B and J-STD-020A with the reflow conditions applicable for packages with thickness above 2.5mm :

- Convection 220°C +5/-0°C
- VPR 215-219°C
- IR / Convection 220°C +5/-0°C

The maximum peak temperature during the soldering process should not exceed 220°C (+5°C/-0°C). The time at maximum temperature should range from 10 to 40s max.

**Thermal Management**

The junction to case thermal resistance is 2°C/W maximum. The junction to ambient thermal resistance is dependent on the mounting technology and the addition of heat sink. One of the most commonly used mounting technique consists in using the printed circuit board and the copper lines as heat sink.

**Figure 1. Printed Board Layout Example (not to scale)**

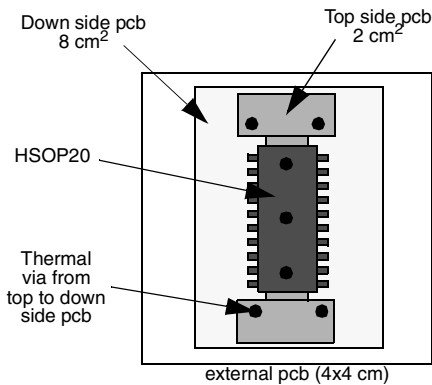

Figure 1 shows an example of printed circuit board layout. It has a total of 10cm<sup>2</sup> additional copper on two sides (2.5 cm<sup>2</sup> on the top side and 7.5 cm<sup>2</sup> on the down side).

With the above layout, thermal resistance junction to ambient of 25°C/W can be achieved, this value being splitted into :

- junction to case :  $R_{thjc1} = R_{thjc2} = 2^\circ\text{C/W}$
- case to ambient :  $R_{thca} = 23^\circ\text{C/W}$ .

Lower value can be reached with the help of larger and thicker copper metal, higher number of thermal via from top to down side pcb and the use of additional thermal via from the circuit board to the module case.

**Steady State Thermal Model**

The junction to ambient thermal resistance of the circuit mounted on a printed circuit board can be splitted into two main parts : junction to case and case to ambient resistances.

A simplified steady state model is shown in figure 2.

**Figure 2. Simplified Thermal Model (Electrical Equivalent)**

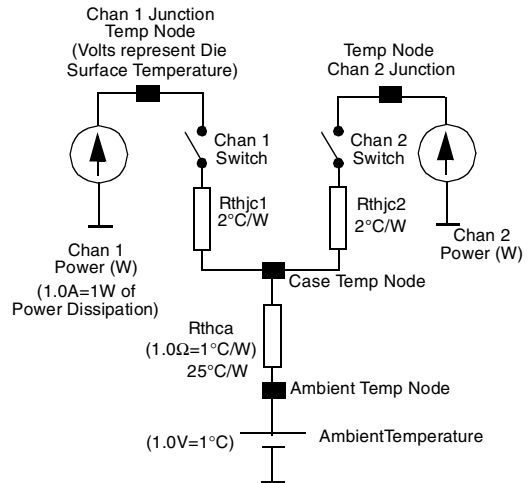

**Transient Thermal Model**

A more complete model including thermal capacitance is proposed in figure 3.

**Figure 3. Transient thermal model**

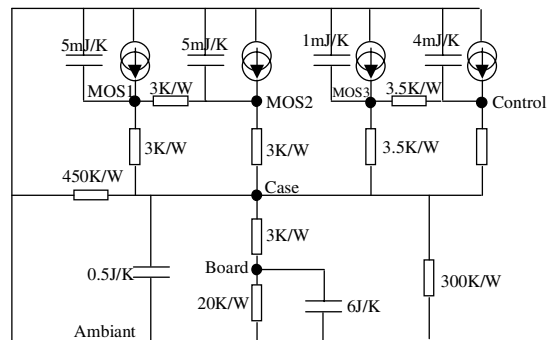

This gives a thermal impedance versus time (figure 4), which has been determined with the printed circuit board shown in figure 1.

**Figure 4. Junction to ambient Thermal impedance**

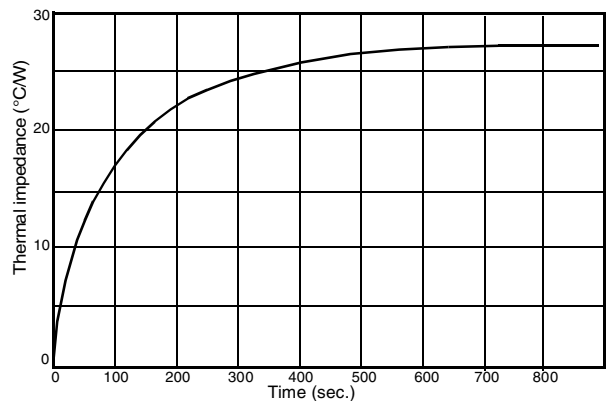

This figure shows that the steady state is reached after about 10 minutes. It also clearly shows that the device can dissipate almost twice the power within one minute compared to the maximum allowed power dissipation in steady state.

Motorola reserves the right to make changes without further notice to any products herein. Motorola makes no warranty, representation or guarantee regarding the suitability of its products for any particular purpose, nor does Motorola assume any liability arising out of the application or use of any product or circuit, and specifically disclaims any and all liability, including without limitation consequential or incidental damages. "Typical" parameters which may be provided in Motorola data sheets and/or specifications can and do vary in different applications and actual performance may vary over time. All operating parameters, including "Typical" must be validated for each customer application by customer's technical experts. Motorola does not convey any license under its patent rights nor the rights of others. Motorola products are not designed, intended, or authorized for use as components in systems intended for surgical implant into the body, or other applications intended to support or sustain life, or for any application in which the failure of the Motorola product could create a situation where personal injury or death may occur. Should Buyer purchase or use Motorola products for any such unintended or unauthorized application, Buyer shall indemnify and hold Motorola and its officers, employees, subsidiaries, affiliates, and distributors harmless against all claims, costs, damages, and expenses, and reasonable attorney fees arising out of, directly or indirectly, any claim of personal injury or death associated with such unintended or un authorized use, even if such claim alleges that Motorola was negligent regarding the design or manufacture of the parts. Motorola and  are registered trademarks of Motorola, Inc. Motorola, Inc. is an Equal Employment Opportunity/Affirmative Action Employer.

**How to reach us:**

**USA / EUROPE / Locations Not Listed:** Motorola Literature Distribution;  
P.O. Box 5405, Denver, Colorado 80217. 1-303-675-2140 or 1-800-441-2447

**JAPAN:** Motorola Japan Ltd.; SPS, Technical Information Center, 3-20-1,  
Minami-Azabu, Minato-ku, Tokyo 106-8573 Japan. 81-3-344-3569

**Technical Information Center: 1-800-521-6274**

**ASIA / PACIFIC:** Motorola Semiconductors H.K. Ltd.; Silicon Harbour Centre,  
2, Dai King Street, Tai Po Industrial Estate, Tai Po, N.T., Hong Kong.  
852-26668334

**HOME PAGE:** <http://www.motorola.com/semiconductors>

