

4M-BIT CMOS FAST SRAM 1M-WORD BY 4-BIT

Description

The μ PD434004A is a high speed, low power, 4,194,304 bits (1,048,576 words by 4 bits) CMOS static RAM.

Operating supply voltage is 5.0 V \pm 0.5 V.

The μ PD434004A is packaged in a 32-pin plastic SOJ.

Features

- 1,048,576 words by 4 bits organization
- Fast access time : 15, 17, 20 ns (MAX.)
- Output Enable input for easy application
- Single +5.0 V power supply

Ordering Information

Part number	Package	Access time ns (MAX.)	Supply current mA (MAX.)	
			At operating	At standby
μ PD434004ALE-15	32-pin plastic SOJ (10.16 mm (400))	15	140	10
μ PD434004ALE-17		17	130	
μ PD434004ALE-20		20	120	

The information in this document is subject to change without notice. Before using this document, please confirm that this is the latest version.
Not all products and/or types are available in every country. Please check with an NEC Electronics sales representative for availability and additional information.

Pin Configuration

/xxx indicates active low signal.

32-pin plastic SOJ (10.16 mm (400))

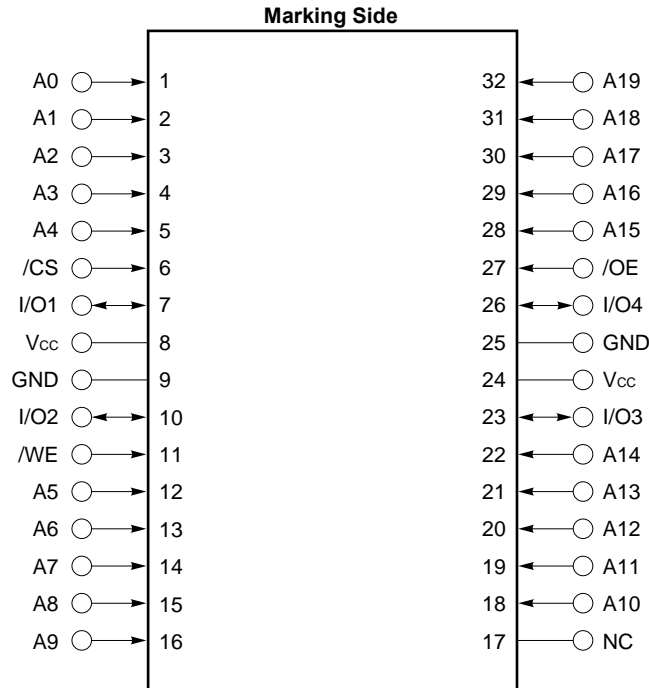

- A0 to A19 : Address Inputs
- I/O1 to I/O4 : Data Inputs / Outputs
- /CS : Chip Select
- /WE : Write Enable
- /OE : Output Enable
- Vcc : Power supply
- GND : Ground
- NC : No connection

Remark Refer to **Package Drawing** for the 1-pin index mark.

Block Diagram

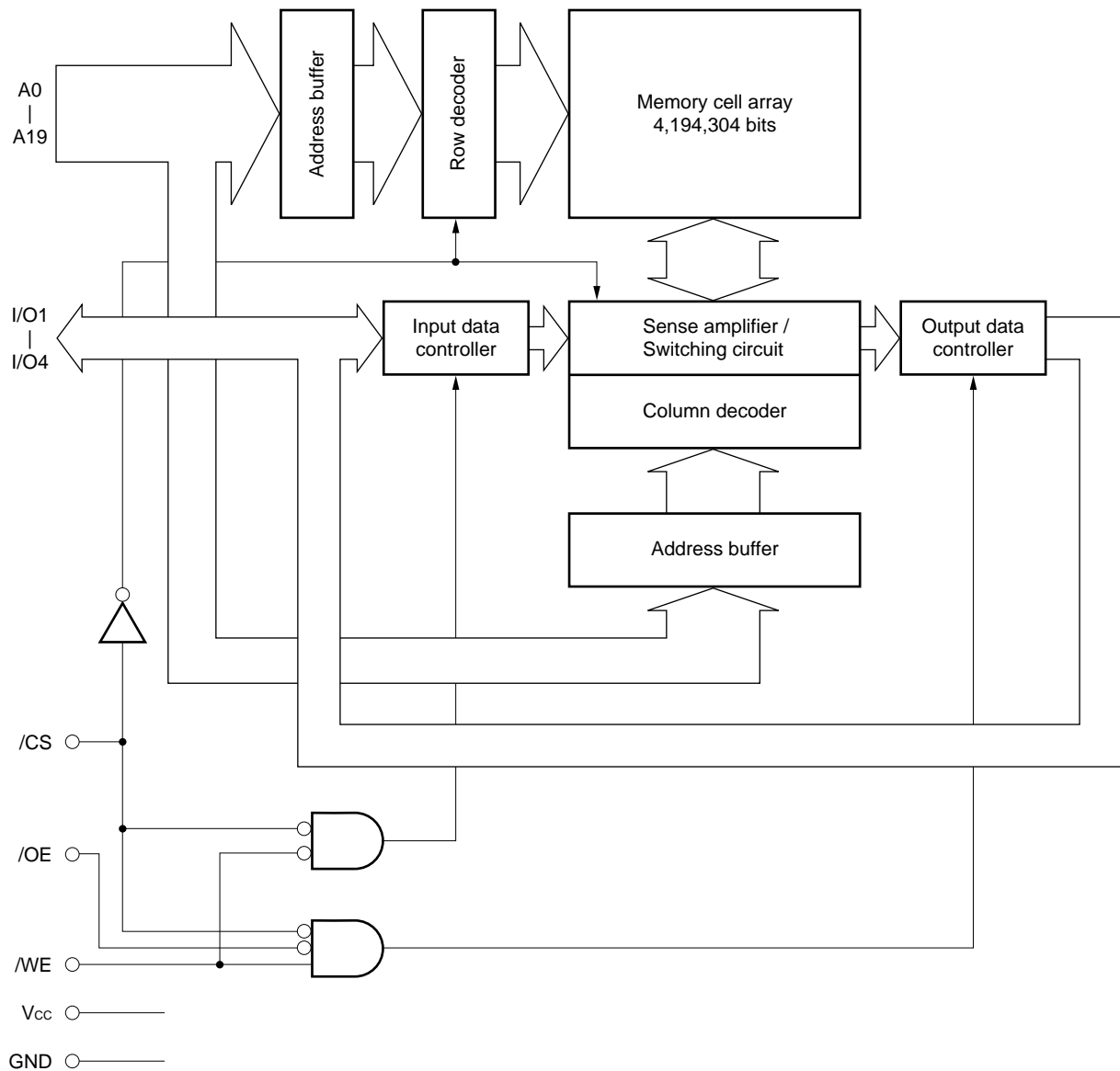

Truth Table

/CS	/OE	/WE	Mode	I/O	Supply current
H	×	×	Not selected	High-Z	I _{SB}
L	L	H	Read	D _{OUT}	I _{CC}
L	×	L	Write	D _{IN}	
L	H	H	Output disable	High-Z	

Remark × : Don't care

Electrical Specifications

Absolute Maximum Ratings

Parameter	Symbol	Condition	Rating	Unit
Supply voltage	V _{CC}		-0.5 ^{Note} to +7.0	V
Input / Output voltage	V _I		-0.5 ^{Note} to V _{CC} +0.5	V
Operating ambient temperature	T _A		0 to 70	°C
Storage temperature	T _{stg}		-55 to +125	°C

Note -2.0 V (MIN.) (pulse width : 2 ns)

Caution Exposing the device to stress above those listed in Absolute Maximum Rating could cause permanent damage. The device is not meant to be operated under conditions outside the limits described in the operational section of this specification. Exposure to Absolute Maximum Rating conditions for extended periods may affect device reliability.

Recommended Operating Conditions

Parameter	Symbol	Condition	MIN.	TYP.	MAX.	Unit
Supply voltage	V _{CC}		4.5	5.0	5.5	V
High level input voltage	V _{IH}		2.2		V _{CC} +0.5	V
Low level input voltage	V _{IL}		-0.5 ^{Note}		+0.8	V
Operating ambient temperature	T _A		0		70	°C

Note -2.0 V (MIN.) (pulse width : 2 ns)

DC Characteristics (Recommended Operating Conditions Unless Otherwise Noted)

Parameter	Symbol	Test condition	MIN.	TYP.	MAX.	Unit
Input leakage current	I _{LI}	V _{IN} = 0 V to V _{CC}	-2		+2	μA
Output leakage current	I _{LO}	V _{I/O} = 0 V to V _{CC} , /CS = V _{IH} or /OE = V _{IH} or /WE = V _{IL}	-2		+2	μA
Operating supply current	I _{CC}	/CS = V _{IL} , I _{I/O} = 0 mA, Minimum cycle time				
		Cycle time : 15 ns			140	mA
		Cycle time : 17 ns			130	
Cycle time : 20 ns			120			
Standby supply current	I _{SB}	/CS = V _{IH} , V _{IN} = V _{IH} or V _{IL}			50	mA
	I _{SB1}	/CS ≥ V _{CC} - 0.2 V, V _{IN} ≤ 0.2 V or V _{IN} ≥ V _{CC} - 0.2 V			10	
High level output voltage	V _{OH}	I _{OH} = -4.0 mA	2.4			V
Low level output voltage	V _{OL}	I _{OL} = +8.0 mA			0.4	V

Remark V_{IN} : Input voltage
V_{I/O} : Input / Output voltage

Capacitance (T_A = 25 °C, f = 1 MHz)

Parameter	Symbol	Test condition	MIN.	TYP.	MAX.	Unit
Input capacitance	C _{IN}	V _{IN} = 0 V			6	pF
Input / Output capacitance	C _{I/O}	V _{I/O} = 0 V			10	pF

Remarks 1. V_{IN} : Input voltage
V_{I/O} : Input / Output voltage
2. These parameters are periodically sampled and not 100% tested.

AC Characteristics (Recommended Operating Conditions Unless Otherwise Noted)

AC Test Conditions

Input Waveform (Rise and Fall Time ≤ 3 ns)

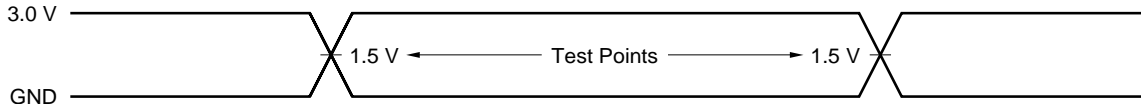

Output Waveform

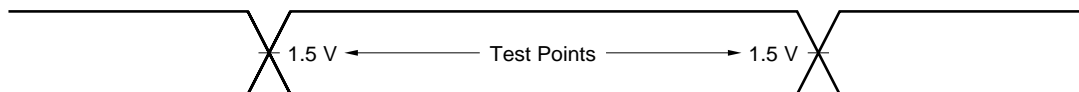

Output Load

AC characteristics directed with the note should be measured with the output load shown in **Figure 1** or **Figure 2**.

Figure 1

(for t_{AA} , t_{ACS} , t_{OE} , t_{OH})

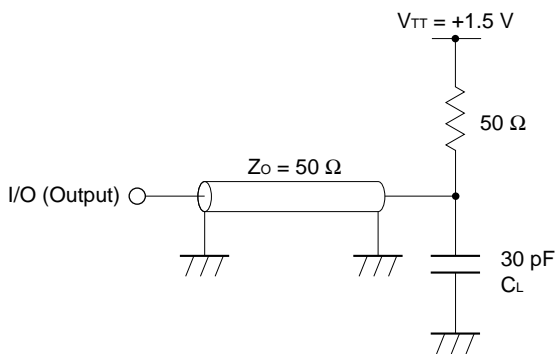
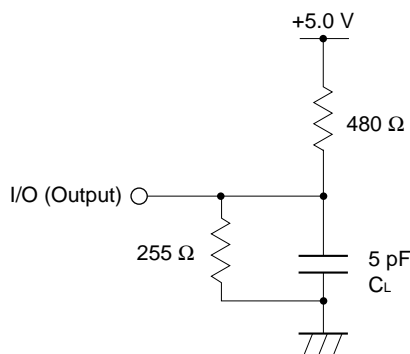

Figure 2

(for t_{CLZ} , t_{OLZ} , t_{CHZ} , t_{OHZ} , t_{WHZ} , t_{OW})



Remark C_L includes capacitances of the probe and jig, and stray capacitances.

Read Cycle

Parameter	Symbol	-15		-17		-20		Unit	Notes
		MIN.	MAX.	MIN.	MAX.	MIN.	MAX.		
Read cycle time	t _{RC}	15		17		20		ns	
Address access time	t _{AA}		15		17		20	ns	1
/CS access time	t _{ACS}		15		17		20	ns	
/OE access time	t _{OE}		7		8		10	ns	
Output hold from address change	t _{OH}	3		3		3		ns	
/CS to output in low impedance	t _{CLZ}	3		3		3		ns	2, 3
/OE to output in low impedance	t _{OLZ}	0		0		0		ns	
/CS to output in high impedance	t _{CHZ}		7		8		8	ns	
/OE to output hold in high impedance	t _{OHZ}		7		8		8	ns	

- Notes**
1. See the output load shown in **Figure 1**.
 2. Transition is measured at ± 200 mV from steady-state voltage with the output load shown in **Figure 2**.
 3. These parameters are periodically sampled and not 100% tested.

Read Cycle Timing Chart 1 (Address Access)

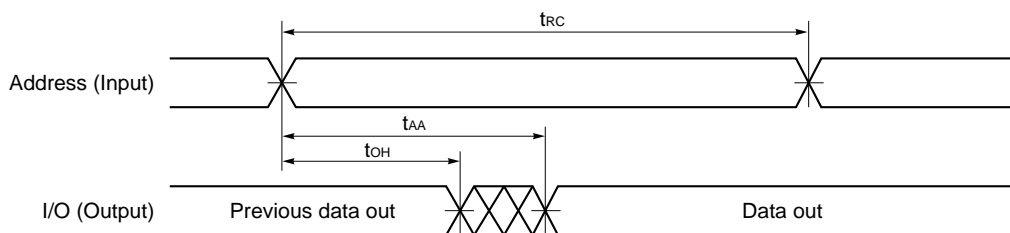

- Remarks**
1. In read cycle, /WE should be fixed to high level.
 2. /CS = /OE = V_{IL}

Read Cycle Timing Chart 2 (/CS Access)

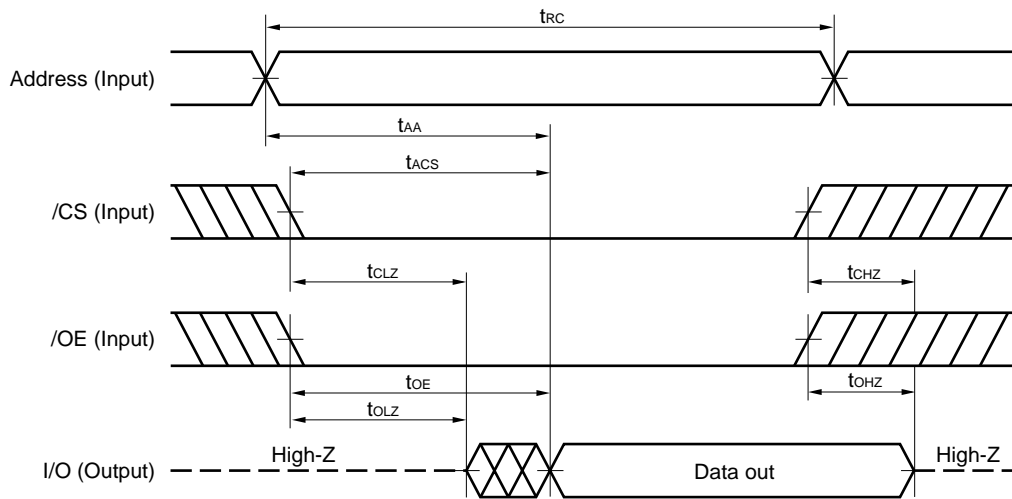

Caution Address valid prior to or coincident with /CS low level input.

Remark In read cycle, /WE should be fixed to high level.

Write Cycle

Parameter	Symbol	-15		-17		-20		Unit	Notes
		MIN.	MAX.	MIN.	MAX.	MIN.	MAX.		
Write cycle time	t_{wc}	15		17		20		ns	
/CS to end of write	t_{cw}	10		11		12		ns	
Address valid to end of write	t_{aw}	10		11		12		ns	
Write pulse width	t_{wp}	10		11		12		ns	
Data valid to end of write	t_{dw}	7		8		9		ns	
Data hold time	t_{dh}	0		0		0		ns	
Address setup time	t_{as}	0		0		0		ns	
Write recovery time	t_{wr}	1		1		1		ns	
/WE to output in high impedance	t_{whz}		7		8		8	ns	1, 2
Output active from end of write	t_{ow}	3		3		3		ns	

- Notes**
1. Transition is measured at ± 200 mV from steady-state voltage with the output load shown in **Figure 2**.
 2. These parameters are periodically sampled and not 100% tested.

Write Cycle Timing Chart 1 (/WE Controlled)

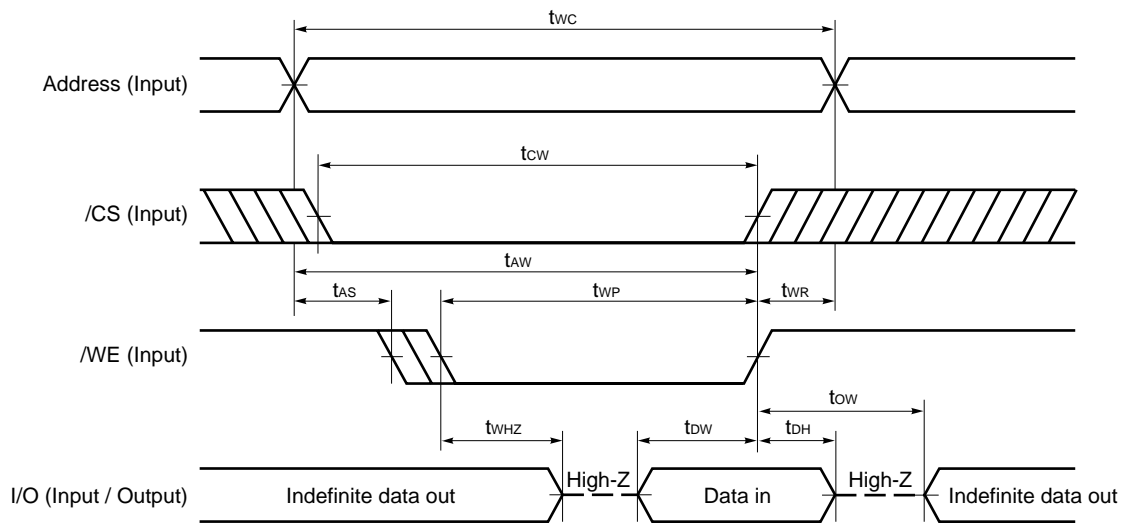

Caution /CS or /WE should be fixed to high level during address transition.

- Remarks**
1. Write operation is done during the overlap time of a low level /CS and a low level /WE.
 2. During t_{whz} , I/O pins are in the output state, therefore the input signals must not be applied to the output.
 3. When /WE is at low level, the I/O pins are always high impedance. When /WE is at high level, read operation is executed. Therefore /OE should be at high level to make the I/O pins high impedance.

Write Cycle Timing Chart 2 (/CS Controlled)

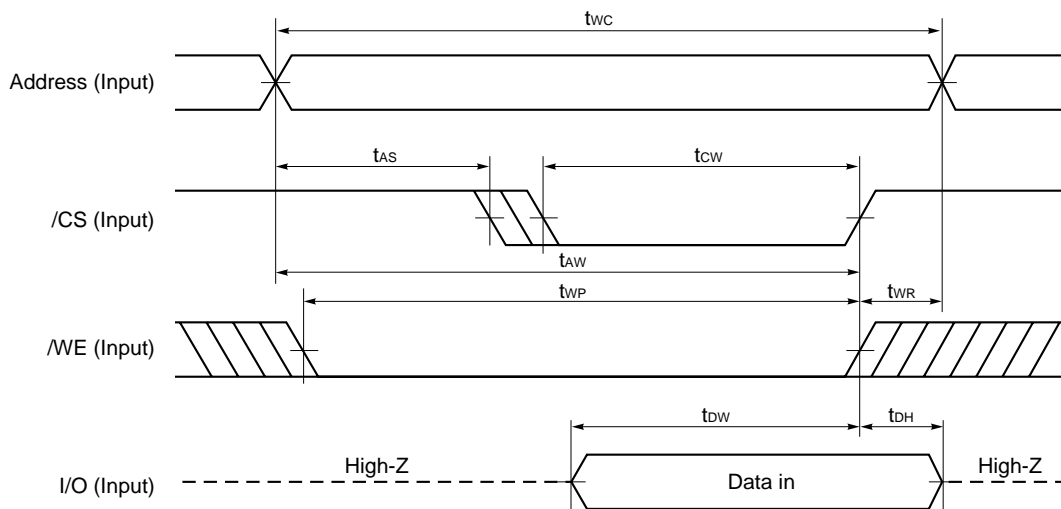

Caution /CS or /WE should be fixed to high level during address transition.

Remark Write operation is done during the overlap time of a low level /CS and a low level /WE.

Package Drawing

32-PIN PLASTIC SOJ (10.16mm (400))

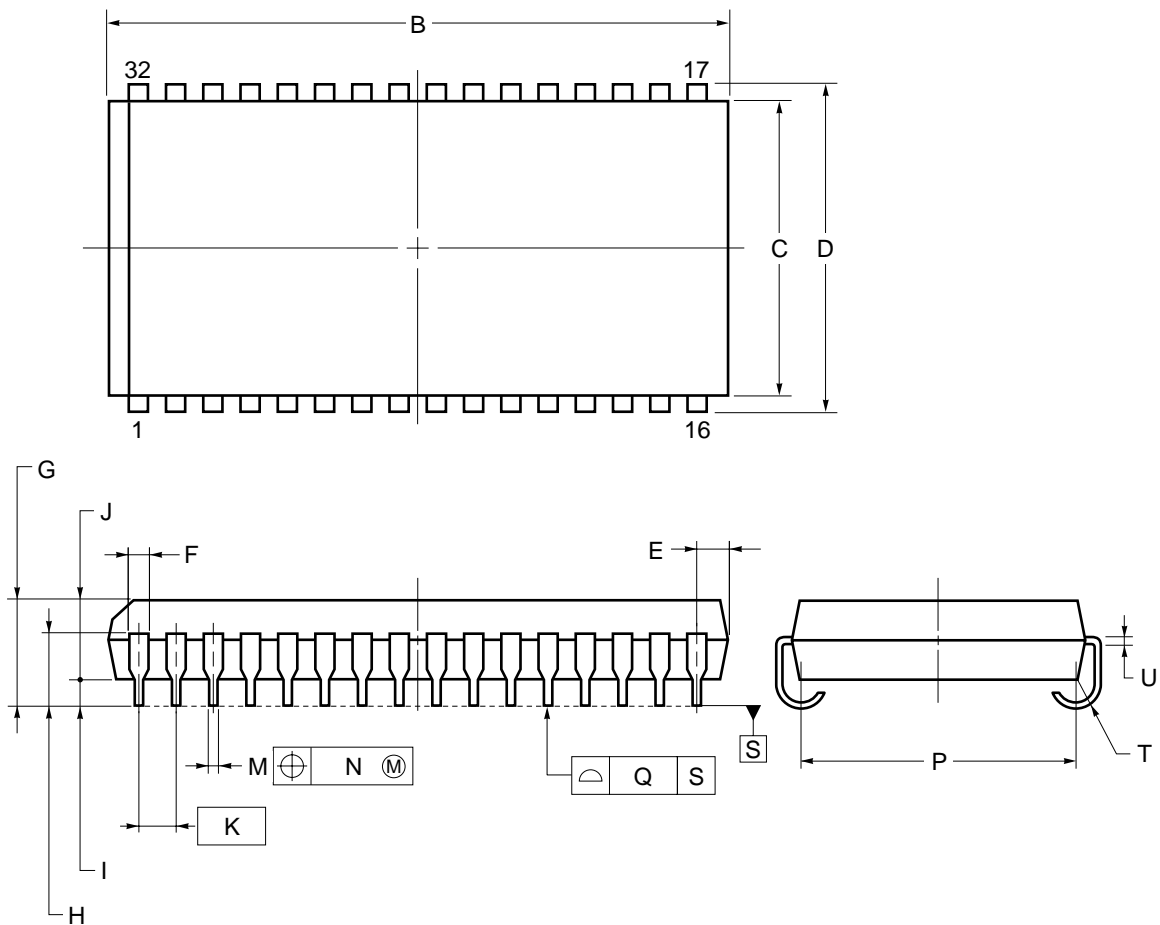

NOTE

Each lead centerline is located within 0.12 mm of its true position (T.P.) at maximum material condition.

ITEM	MILLIMETERS
B	21.26±0.2
C	10.16
D	11.18±0.2
E	1.005±0.1
F	0.74
G	3.5±0.2
H	2.545±0.2
I	0.8 MIN.
J	2.6
K	1.27(T.P.)
M	0.40±0.10
N	0.12
P	9.4±0.20
Q	0.1
T	R0.85
U	0.20 ^{+0.10} _{-0.05}
P32LE-400A-1	

Recommended Soldering Conditions

Please consult with our sales offices for soldering conditions of the μ PD434004A.

Type of Surface Mount Device

μ PD434004ALE : 32-pin plastic SOJ (10.16 mm (400))

[MEMO]

[MEMO]

NOTES FOR CMOS DEVICES**① PRECAUTION AGAINST ESD FOR SEMICONDUCTORS**

Note:

Strong electric field, when exposed to a MOS device, can cause destruction of the gate oxide and ultimately degrade the device operation. Steps must be taken to stop generation of static electricity as much as possible, and quickly dissipate it once, when it has occurred. Environmental control must be adequate. When it is dry, humidifier should be used. It is recommended to avoid using insulators that easily build static electricity. Semiconductor devices must be stored and transported in an anti-static container, static shielding bag or conductive material. All test and measurement tools including work bench and floor should be grounded. The operator should be grounded using wrist strap. Semiconductor devices must not be touched with bare hands. Similar precautions need to be taken for PW boards with semiconductor devices on it.

② HANDLING OF THE APPLIED WAVEFORM OF INPUT PINS AND THE UNUSED INPUT PINS FOR CMOS

Note:

Input levels of CMOS devices must be fixed. CMOS devices behave differently than Bipolar or NMOS devices. If the input of a CMOS device stays in an area that is between V_{IL} (MAX.) and V_{IH} (MIN.) due to the effects of noise or some other irregularity, malfunction may result. Therefore, not only the input waveform is fixed, but also the waveform changes, it is important to use the CMOS device under AC test conditions. For unused input pins in particular, CMOS devices should not be operated in a state where nothing is connected, so input levels of CMOS devices must be fixed to high or low by using pull-up or pull-down circuitry. Each unused pin should be connected to V_{DD} or GND with a resistor, if it is considered to have a possibility of being an output pin. All handling related to the unused pins must be judged device by device and related specifications governing the devices.

③ STATUS BEFORE INITIALIZATION OF MOS DEVICES

Note:

Power-on does not necessarily define initial status of MOS device. Production process of MOS does not define the initial operation status of the device. Immediately after the power source is turned ON, the devices with reset function have not yet been initialized. Hence, power-on does not guarantee out-pin levels, I/O settings or contents of registers. Device is not initialized until the reset signal is received. Reset operation must be executed immediately after power-on for devices having reset function.

- **The information in this document is current as of December, 2002. The information is subject to change without notice. For actual design-in, refer to the latest publications of NEC Electronics data sheets or data books, etc., for the most up-to-date specifications of NEC Electronics products. Not all products and/or types are available in every country. Please check with an NEC Electronics sales representative for availability and additional information.**
- No part of this document may be copied or reproduced in any form or by any means without the prior written consent of NEC Electronics. NEC Electronics assumes no responsibility for any errors that may appear in this document.
- NEC Electronics does not assume any liability for infringement of patents, copyrights or other intellectual property rights of third parties by or arising from the use of NEC Electronics products listed in this document or any other liability arising from the use of such products. No license, express, implied or otherwise, is granted under any patents, copyrights or other intellectual property rights of NEC Electronics or others.
- Descriptions of circuits, software and other related information in this document are provided for illustrative purposes in semiconductor product operation and application examples. The incorporation of these circuits, software and information in the design of a customer's equipment shall be done under the full responsibility of the customer. NEC Electronics assumes no responsibility for any losses incurred by customers or third parties arising from the use of these circuits, software and information.
- While NEC Electronics endeavors to enhance the quality, reliability and safety of NEC Electronics products, customers agree and acknowledge that the possibility of defects thereof cannot be eliminated entirely. To minimize risks of damage to property or injury (including death) to persons arising from defects in NEC Electronics products, customers must incorporate sufficient safety measures in their design, such as redundancy, fire-containment and anti-failure features.
- NEC Electronics products are classified into the following three quality grades: "Standard", "Special" and "Specific".

The "Specific" quality grade applies only to NEC Electronics products developed based on a customer-designated "quality assurance program" for a specific application. The recommended applications of an NEC Electronics product depend on its quality grade, as indicated below. Customers must check the quality grade of each NEC Electronics product before using it in a particular application.

"Standard": Computers, office equipment, communications equipment, test and measurement equipment, audio and visual equipment, home electronic appliances, machine tools, personal electronic equipment and industrial robots.

"Special": Transportation equipment (automobiles, trains, ships, etc.), traffic control systems, anti-disaster systems, anti-crime systems, safety equipment and medical equipment (not specifically designed for life support).

"Specific": Aircraft, aerospace equipment, submersible repeaters, nuclear reactor control systems, life support systems and medical equipment for life support, etc.

The quality grade of NEC Electronics products is "Standard" unless otherwise expressly specified in NEC Electronics data sheets or data books, etc. If customers wish to use NEC Electronics products in applications not intended by NEC Electronics, they must contact an NEC Electronics sales representative in advance to determine NEC Electronics' willingness to support a given application.

(Note)

- (1) "NEC Electronics" as used in this statement means NEC Electronics Corporation and also includes its majority-owned subsidiaries.
- (2) "NEC Electronics products" means any product developed or manufactured by or for NEC Electronics (as defined above).