

LM4674 Boomer® Audio Power Amplifier Series

Filterless 2.5W Stereo Class D Audio Power Amplifier

General Description

The LM4674 is a single supply, high efficiency, 2.5W/channel, filterless switching audio amplifier. A low noise PWM architecture eliminates the output filter, reducing external component count, board area consumption, system cost, and simplifying design.

The LM4674 is designed to meet the demands of mobile phones and other portable communication devices. Operating from a single 5V supply, the device is capable of delivering 2.5W/channel of continuous output power to a 4Ω load with less than 10% THD+N. Flexible power supply requirements allow operation from 2.4V to 5.5V.

The LM4674 features high efficiency compared to conventional Class AB amplifiers. When driving an 8Ω speaker from a 3.6V supply, the device features 85% efficiency at $P_O = 500\text{mW}$. Four gain options are pin selectable through the GAIN0 and GAIN1 pins.

Output short circuit protection prevents the device from being damaged during fault conditions. Superior click and pop suppression eliminates audible transients on power-up/down and during shutdown. Independent left/right shutdown controls maximize power savings in mixed mono/stereo applications.

Key Specifications

■ Efficiency at 3.6V, 100mW into 8Ω	80% (typ)
■ Efficiency at 3.6V, 500mW into 8Ω	85% (typ)
■ Efficiency at 5V, 1W into 8Ω	85% (typ)
■ Quiescent Power Supply Current at 3.6V supply	4mA
■ Power Output at $V_{DD} = 5\text{V}$, $R_L = 4\Omega$, THD $\leq 10\%$	2.5W (typ)
■ Power Output at $V_{DD} = 5\text{V}$, $R_L = 8\Omega$, THD $\leq 10\%$	1.5W (typ)
■ Shutdown current	0.1μA (typ)

Features

- Output Short Circuit Protection
- Stereo Class D operation
- No output filter required
- Logic selectable gain
- Independent shutdown control
- Minimum external components
- Click and Pop suppression
- Micro-power shutdown
- Available in space-saving 2mm x 2mm x 0.6mm micro SMD package

Applications

- Mobile phones
- PDAs
- Laptops

Typical Application

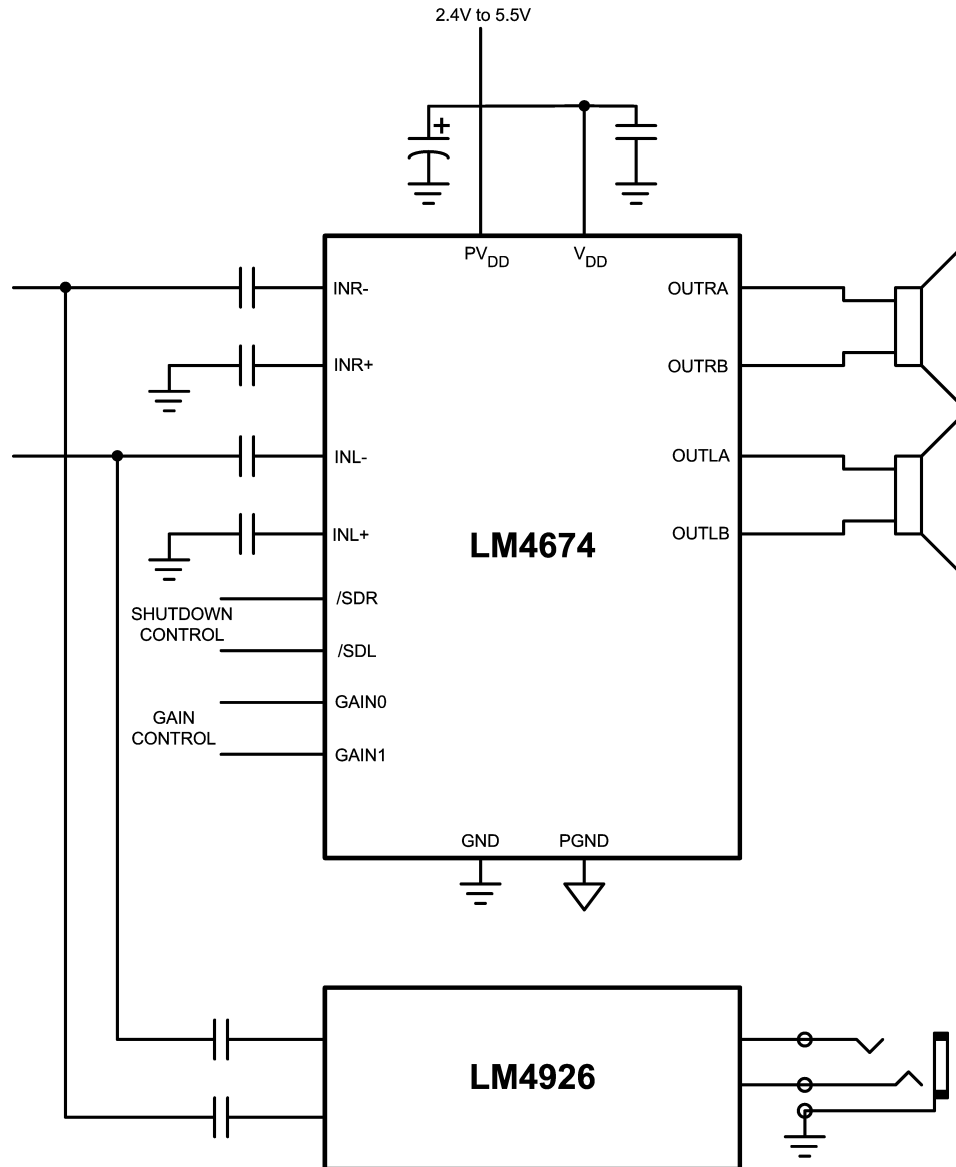

20167402

* Bypass output should be left floating for proper operation in most applications. See **Application Information** for details.

FIGURE 1. Typical Audio Amplifier Application Circuit

Connection Diagrams

TL Package (2mmx2mmx0.6mm)

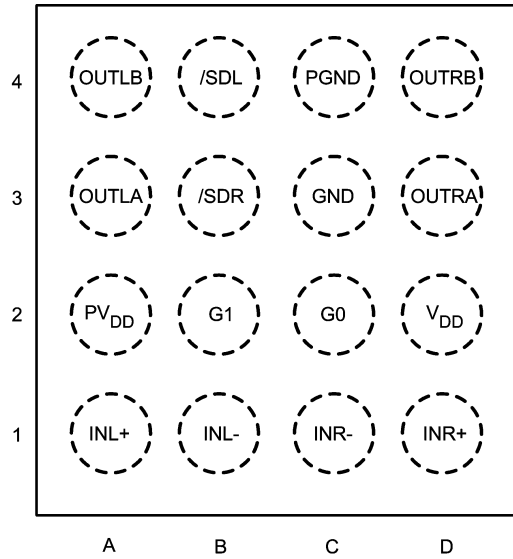

20167401

Top View

Order Number LM4674TL
See NS Package Number TL1611A

LM4674TL Markings

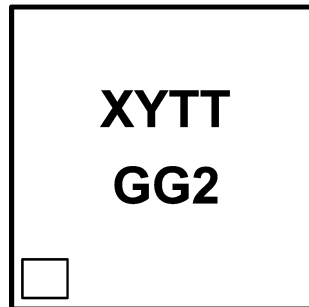

20167425

Top View

XY = 2 digit datecode
TT = Die traceability
G = Boomer Family
G2 = LM4674TL

Absolute Maximum Ratings (Notes 1, 2)

If Military/Aerospace specified devices are required, please contact the National Semiconductor Sales Office/Distributors for availability and specifications.

Supply Voltage (Note 1)	6.0V
Storage Temperature	-65°C to +150°C
Input Voltage	-0.3V to $V_{DD} + 0.3V$
Power Dissipation (Note 3)	Internally Limited
ESD Susceptibility, all other pins (Note 4)	2000V
ESD Susceptibility (Note 5)	200V

Junction Temperature (T_{JMAX}) 150°C

Thermal Resistance
 θ_{JA} 45.7°C/W

Operating Ratings (Note 1) (Note 2)

Temperature Range	$T_{MIN} \leq T_A \leq T_{MAX}$	-40°C ≤ T_A ≤ 85°C
Supply Voltage		2.4V ≤ V_{DD} ≤ 5.5V

Electrical Characteristics $V_{DD} = 3.6V$ (Notes 1, 2)

The following specifications apply for $A_V = 6dB$, $R_L = 15\mu H + 8\Omega + 15\mu H$, $f = 1kHz$ unless otherwise specified. Limits apply for $T_A = 25^\circ C$.

Symbol	Parameter	Conditions	LM4674		Units (Limits)
			Typical	Limit	
			(Note 6)	(Note 7)	
V_{OS}	Differential Output Offset Voltage	$V_{IN} = 0$, $V_{DD} = 2.4V$ to $5.0V$	5		mV
I_{DD}	Quiescent Power Supply Current	$V_{IN} = 0$, $R_L = \infty$, Both channels active, $V_{DD} = 3.6V$	4	6	mA
		$V_{IN} = 0$, $R_L = \infty$, Both channels active, $V_{DD} = 5V$	5	7.5	
I_{SD}	Shutdown Current	$V_{SD1} = V_{SD2} = GND$	0.03	1	μA
V_{SDIH}	Shutdown Voltage Input High			1.4	V (min)
V_{SDIL}	Shutdown Voltage Input Low			0.4	V (max)
T_{WU}	Wake Up Time	$V_{SHUTDOWN} = 0.4V$	0.5		ms
A_V	Gain	$GAIN0$, $GAIN1 = GND$	6	6 ± 0.5	dB
		$GAIN0 = V_{DD}$, $GAIN1 = GND$	12	12 ± 0.5	
		$GAIN0 = GND$, $GAIN1 = V_{DD}$	18	18 ± 0.5	
		$GAIN0$, $GAIN1 = V_{DD}$	24	24 ± 0.5	
R_{IN}	Input Resistance	$A_V = 6dB$	28		k Ω
		$A_V = 12dB$	18.75		
		$A_V = 18dB$	11.25		
		$A_V = 24dB$	6.25		

Electrical Characteristics $V_{DD} = 3.6V$ (Notes 1, 2)

The following specifications apply for $A_V = 6dB$, $R_L = 15\mu H + 8\Omega + 15\mu H$, $f = 1kHz$ unless otherwise specified. Limits apply for $T_A = 25^\circ C$. (Continued)

Symbol	Parameter	Conditions	LM4674		Units (Limits)
			Typical	Limit	
			(Note 6)	(Note 7)	
P_O	Output Power	$R_L = 15\mu H + 4\Omega + 15\mu H$, THD = 10% $f = 1kHz$, 22kHz BW			W
		$V_{DD} = 5V$	2.5		
		$V_{DD} = 3.6V$	1.2		
			$V_{DD} = 2.5V$	0.530	
		$R_L = 15\mu H + 8\Omega + 15\mu H$, THD = 10% $f = 1kHz$, 22kHz BW			W
		$V_{DD} = 5V$	1.5		
		$V_{DD} = 3.6V$	0.78	0.6	
			$V_{DD} = 2.5V$	0.350	
		$R_L = 15\mu H + 4\Omega + 15\mu H$, THD = 1% $f = 1kHz$, 22kHz BW			W
		$V_{DD} = 5V$	1.9		
		$V_{DD} = 3.6V$	1		
			$V_{DD} = 2.5V$	0.430	
		$R_L = 15\mu H + 8\Omega + 15\mu H$, THD = 1% $f = 1kHz$, 22kHz BW			W
		$V_{DD} = 5V$	1.25		
		$V_{DD} = 3.6V$	0.63		
			$V_{DD} = 2.5V$	0.285	
THD+N	Total Harmonic Distortion	$P_O = 500mW$, $f = 1kHz$, $R_L = 8\Omega$	0.07		%
		$P_O = 300mW$, $f = 1kHz$, $R_L = 8\Omega$	0.05		
PSRR	Power Supply Rejection Ratio	$V_{RIPPLE} = 200mV_{P-P}$ Sine, $f_{RIPPLE} = 217Hz$, Inputs AC GND, $C_1 = 1\mu F$, input referred	75		dB
		$V_{RIPPLE} = 1V_{P-P}$ Sine, $f_{RIPPLE} = 1kHz$, Inputs AC GND, $C_1 = 1\mu F$, input referred	75		
CMRR	Common Mode Rejection Ratio	$V_{RIPPLE} = 1V_{P-P}$ $f_{RIPPLE} = 217Hz$	67		dB
η	Efficiency	$P_O = 1W$, $f = 1kHz$, $R_L = 8\Omega$, $V_{DD} = 5V$	85		%
	Crosstalk	$P_O = 500mW$, $f = 1kHz$	84		dB
SNR	Signal to Noise Ratio	$V_{DD} = 5V$, $P_O = 1W$	96		dB
ϵ_{OS}	Output Noise	Input referred, A-Weighted Filter	20		μV

Note 1: All voltages are measured with respect to the ground pin, unless otherwise specified.

Note 2: *Absolute Maximum Ratings* indicate limits beyond which damage to the device may occur. *Operating Ratings* indicate conditions for which the device is functional, but do not guarantee specific performance limits. *Electrical Characteristics* state DC and AC electrical specifications under particular test conditions which guarantee specific performance limits. This assumes that the device is within the Operating Ratings. Specifications are not guaranteed for parameters where no limit is given, however, the typical value is a good indication of device performance.

Note 3: The maximum power dissipation must be derated at elevated temperatures and is dictated by T_{JMAX} , θ_{JA} , and the ambient temperature, T_A . The maximum allowable power dissipation is $P_{DMAX} = (T_{JMAX} - T_A) / \theta_{JA}$ or the number given in Absolute Maximum Ratings, whichever is lower. For the LM4674 see power derating currents for more information.

Note 4: Human body model, 100pF discharged through a 1.5k Ω resistor.

Note 5: Machine Model, 220pF–240pF discharged through all pins.

Note 6: Typicals are measured at 25°C and represent the parametric norm.

Note 7: Limits are guaranteed to National's AOQL (Average Outgoing Quality Level).

External Components Description

(Figure 1)

Components		Functional Description
1.	C_S	Supply bypass capacitor which provides power supply filtering. Refer to the Power Supply Bypassing section for information concerning proper placement and selection of the supply bypass capacitor.
2.	C_I	Input AC coupling capacitor which blocks the DC voltage at the amplifier's input terminals.

Block Diagrams

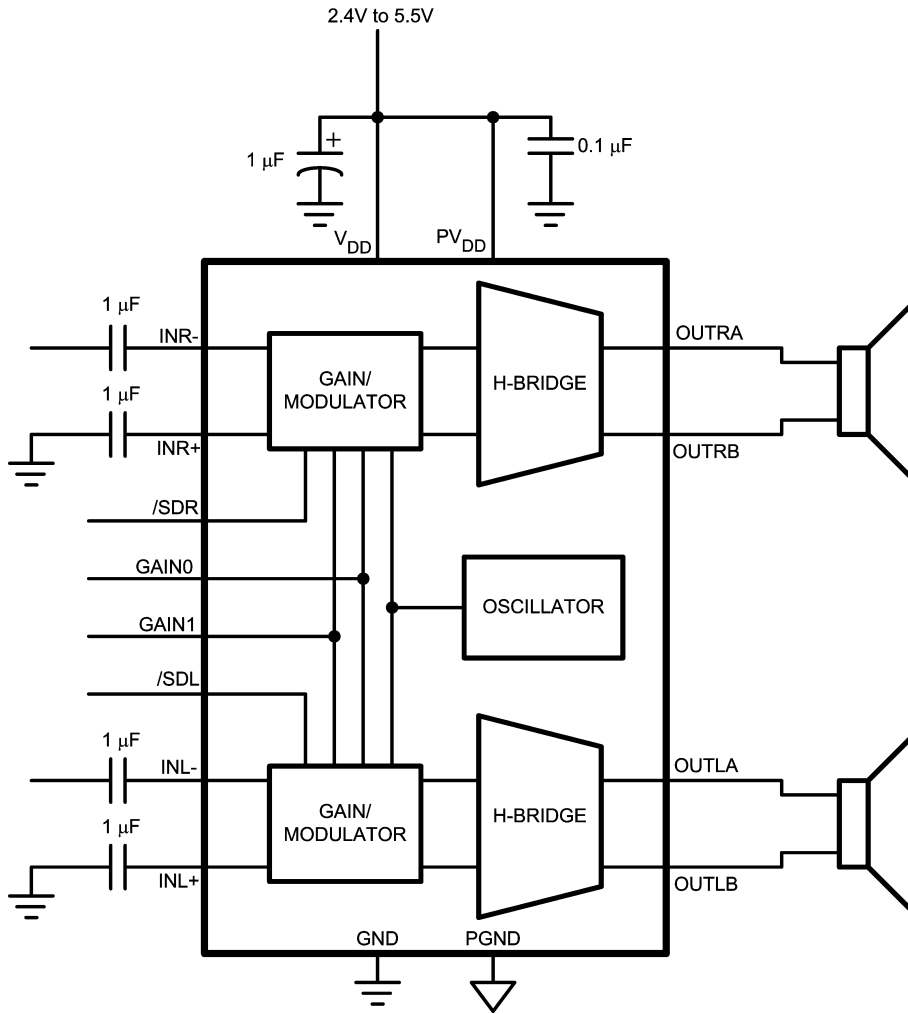

20167437

Block Diagrams (Continued)

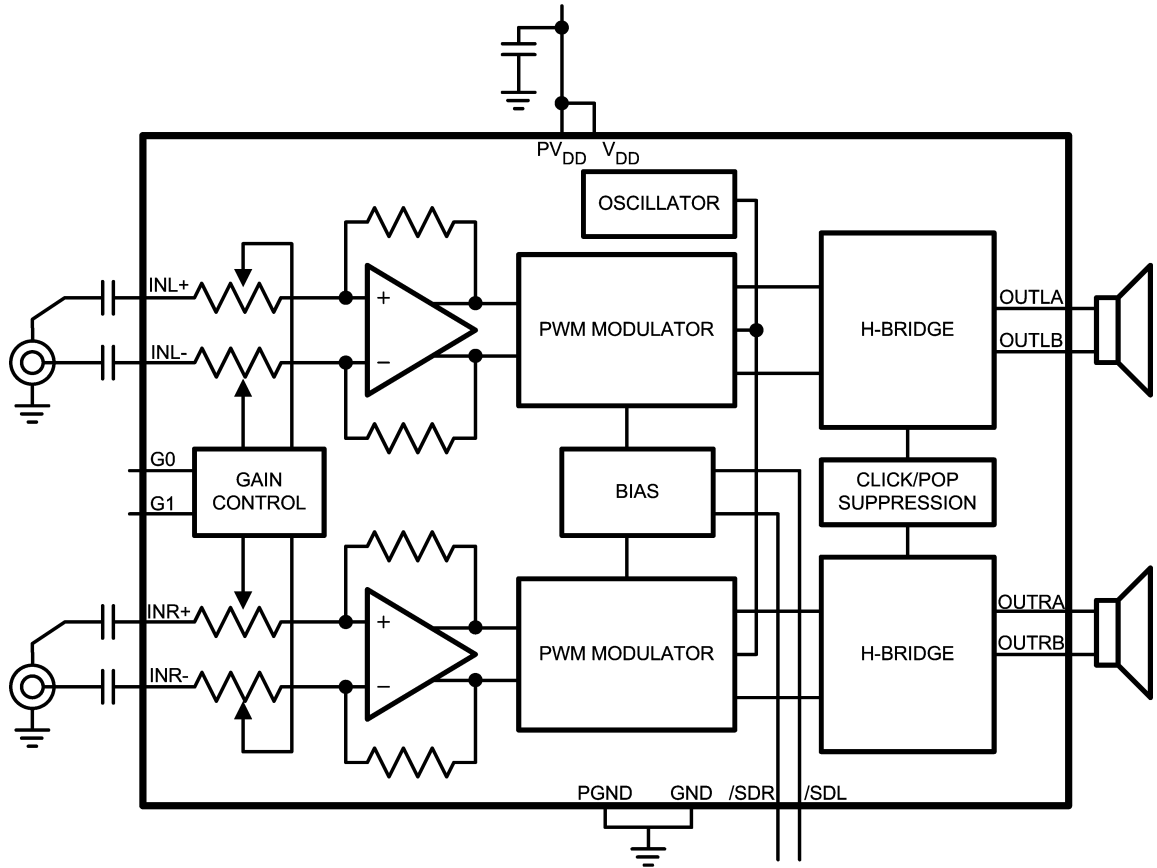

Differential Input Configuration

20167438

Typical Performance Characteristics

THD+N vs Output Power
 $f = 1\text{kHz}, A_V = 24\text{dB}, R_L = 8\Omega$

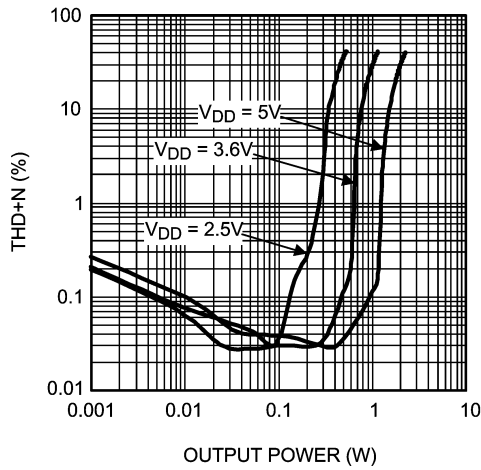

20167439

THD+N vs Output Power
 $f = 1\text{kHz}, A_V = 6\text{dB}, R_L = 8\Omega$

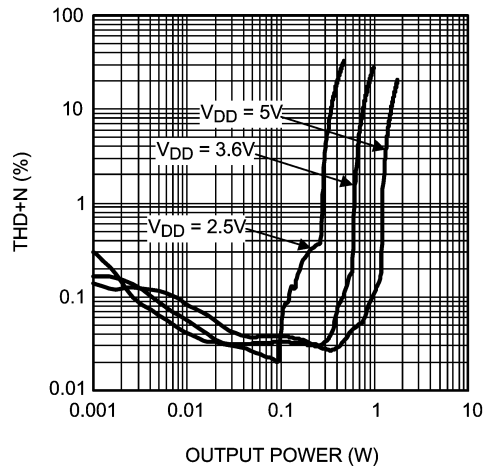

20167440

THD+N vs Output Power
 $f = 1\text{kHz}, A_V = 24\text{dB}, R_L = 4\Omega$

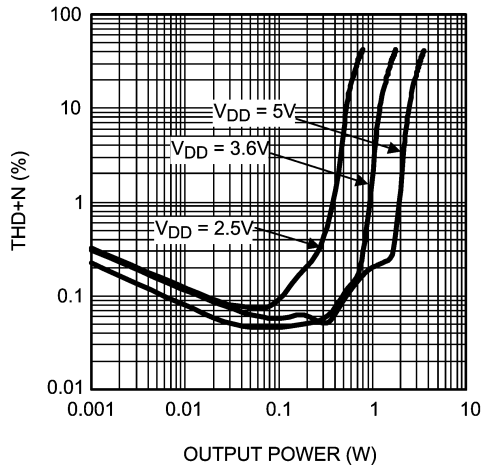

20167441

THD+N vs Output Power
 $f = 1\text{kHz}, A_V = 6\text{dB}, R_L = 4\Omega$

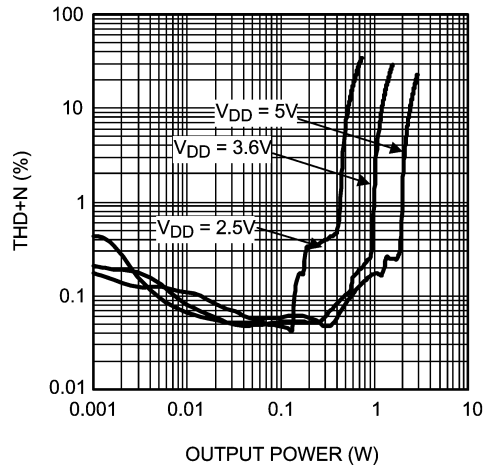

20167442

THD+N vs Frequency
 $V_{DD} = 2.5\text{V}, P_{OUT} = 100\text{mW}, R_L = 8\Omega$

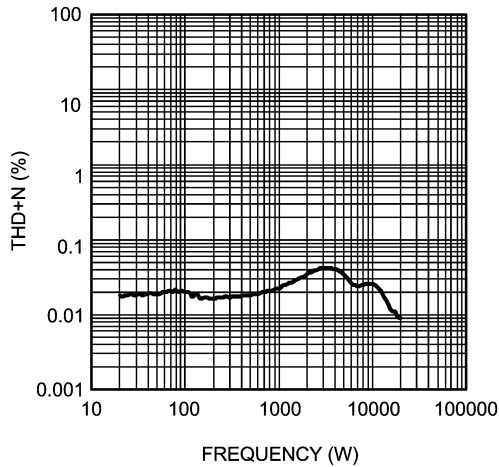

20167443

THD+N vs Frequency
 $V_{DD} = 3.6\text{V}, P_{OUT} = 250\text{mW}, R_L = 8\Omega$

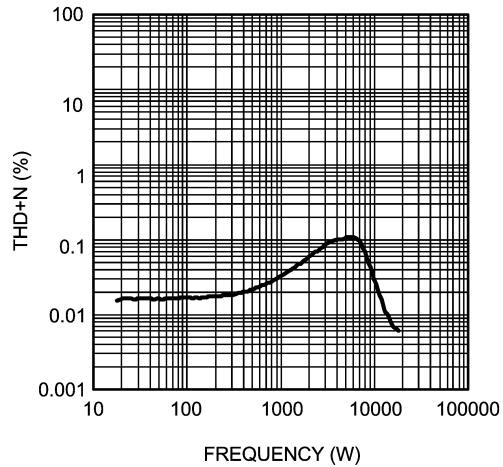

20167444

Typical Performance Characteristics (Continued)

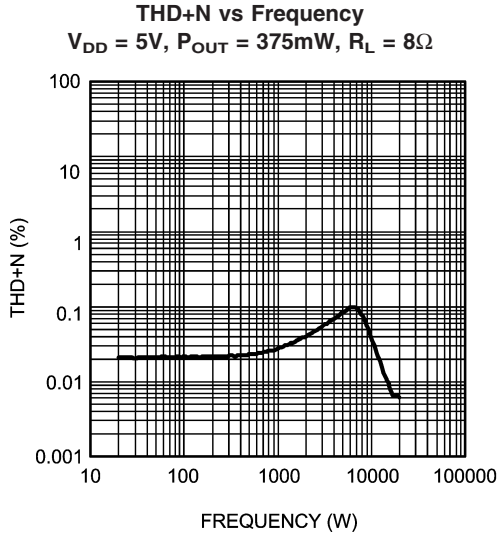

20167445

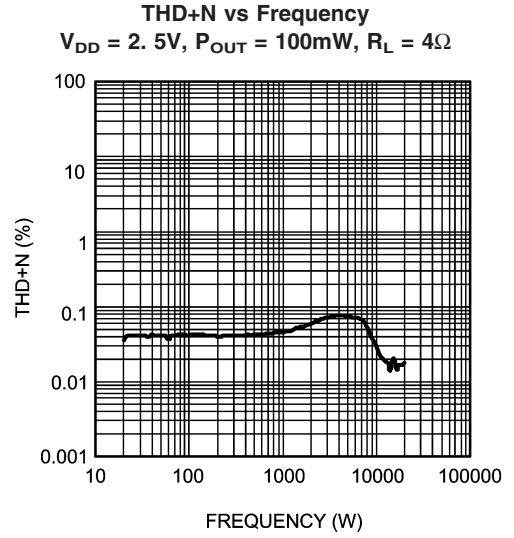

20167446

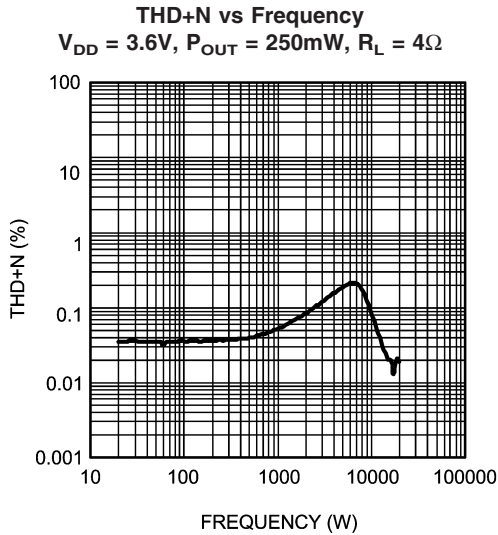

20167447

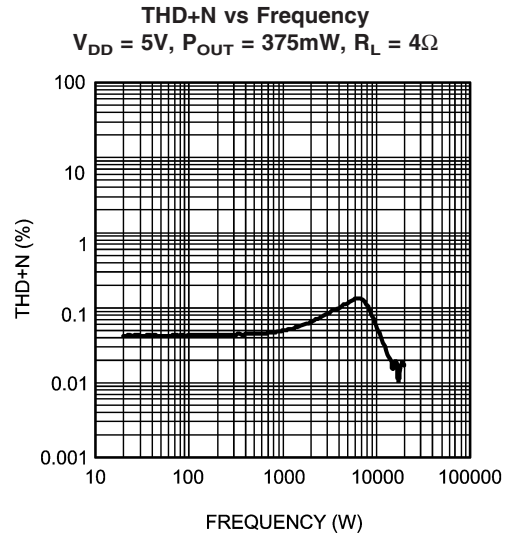

20167448

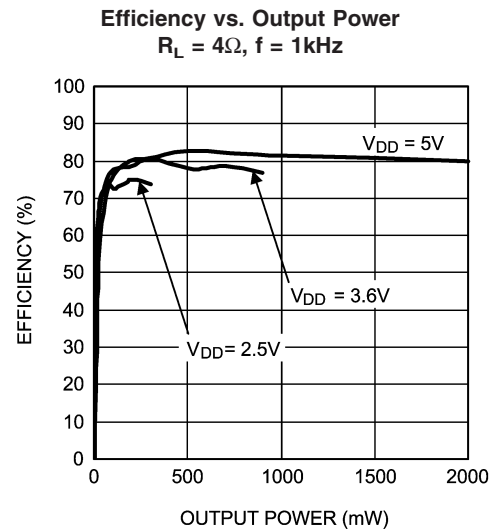

20167449

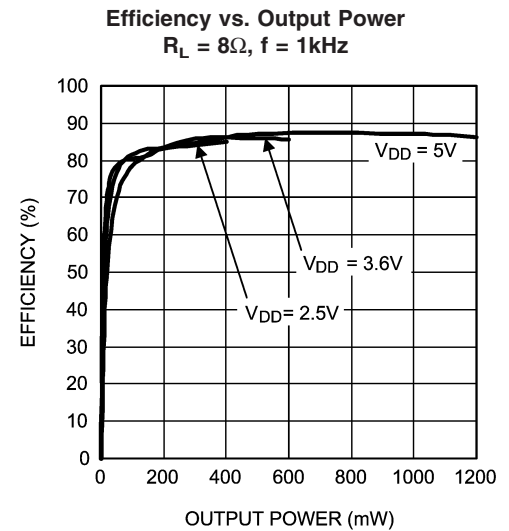

20167450

Typical Performance Characteristics (Continued)

Power Dissipation vs. Output Power
 $R_L = 4\Omega, f = 1\text{kHz}$

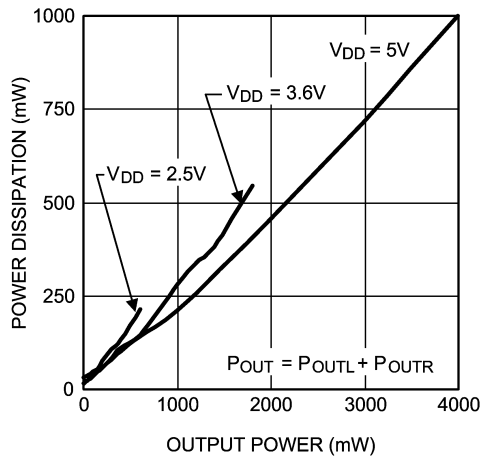

Power Dissipation vs. Output Power
 $R_L = 8\Omega, f = 1\text{kHz}$

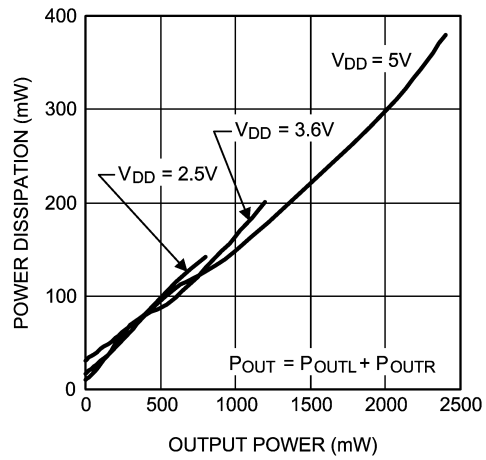

Output Power vs. Supply Voltage
 $R_L = 4\Omega, f = 1\text{kHz}$

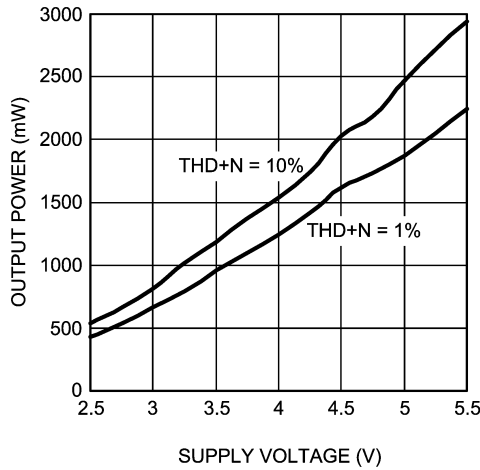

Output Power vs. Supply Voltage
 $R_L = 8\Omega, f = 1\text{kHz}$

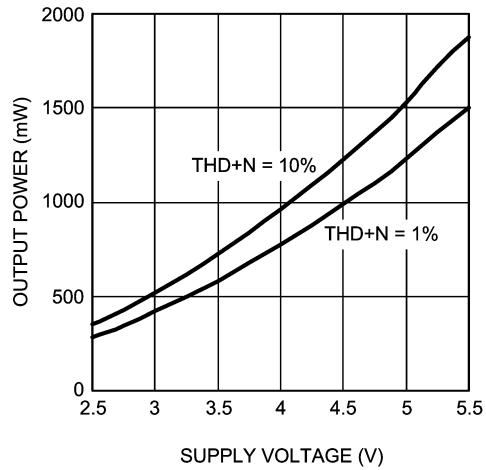

PSRR vs. Frequency
 $V_{DD} = 3.6\text{V}, V_{RIPPLE} = 200\text{mV}_{P-P}, R_L = 8\Omega$

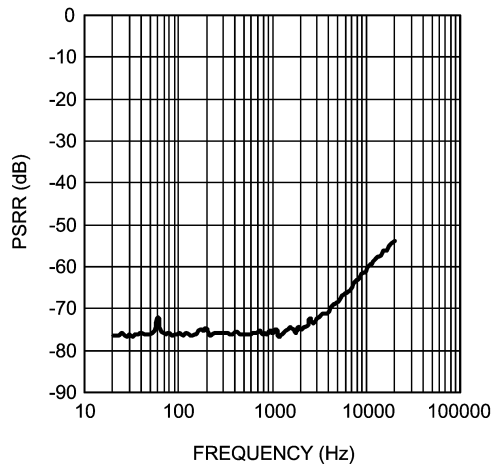

Crosstalk vs. Frequency
 $V_{DD} = 3.6\text{V}, V_{RIPPLE} = 1\text{V}_{P-P}, R_L = 8\Omega$

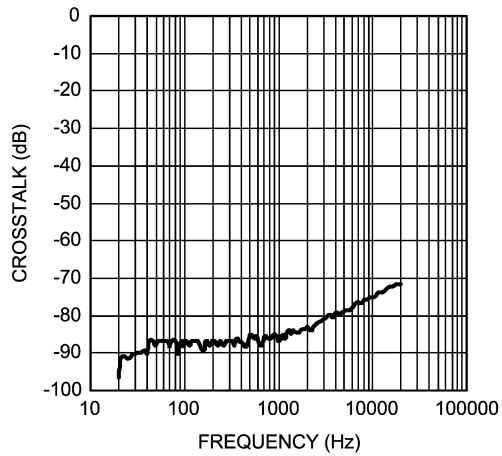

Typical Performance Characteristics (Continued)

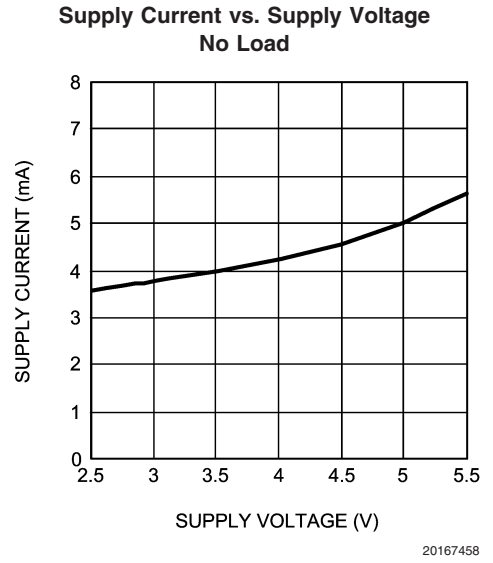
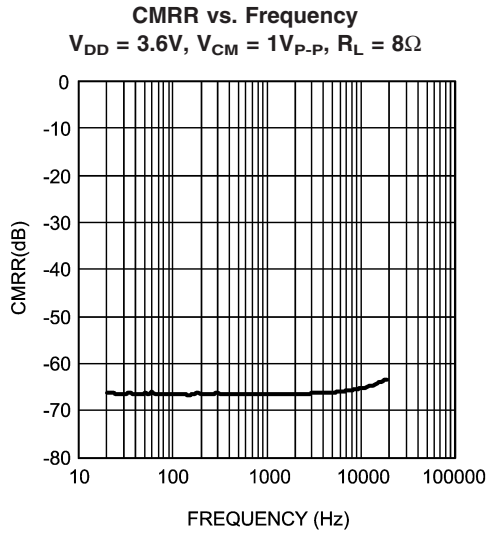

Application Information

GENERAL AMPLIFIER FUNCTION

The LM4674 stereo Class D audio power amplifier features a filterless modulation scheme that reduces external component count, conserving board space and reducing system cost. The outputs of the device transition from V_{DD} to GND with a 300kHz switching frequency. With no signal applied, the outputs (OUT_A and OUT_B) switch with a 50% duty cycle, in phase, causing the two outputs to cancel. This cancellation results in no net voltage across the speaker, thus there is no current to the load in the idle state.

With the input signal applied, the duty cycle (pulse width) of the LM4674 outputs changes. For increasing output voltage, the duty cycle of OUT_A increases, while the duty cycle of OUT_B decreases. For decreasing output voltages, the converse occurs. The difference between the two pulse widths yields the differential output voltage.

DIFFERENTIAL AMPLIFIER EXPLANATION

As logic supplies continue to shrink, system designers are increasingly turning to differential analog signal handling to preserve signal to noise ratios with restricted voltage signs. The LM4674 features two fully differential amplifiers. A differential amplifier amplifies the difference between the two input signals. Traditional audio power amplifiers have typically offered only single-ended inputs resulting in a 6dB reduction of SNR relative to differential inputs. The LM4674 also offers the possibility of DC input coupling which eliminates the input coupling capacitors. A major benefit of the fully differential amplifier is the improved common mode rejection ratio (CMRR) over single ended input amplifiers. The increased CMRR of the differential amplifier reduces sensitivity to ground offset related noise injection, especially important in noisy systems.

POWER DISSIPATION AND EFFICIENCY

The major benefit of a Class D amplifier is increased efficiency versus a Class AB. The efficiency of the LM4674 is attributed to the region of operation of the transistors in the output stage. The Class D output stage acts as current steering switches, consuming negligible amounts of power compared to their Class AB counterparts. Most of the power loss associated with the output stage is due to the IR loss of the MOSFET on-resistance, along with switching losses due to gate charge.

SHUTDOWN FUNCTION

The LM4674 features independent left and right channel shutdown controls, allowing each channel to be disabled independently. /SDR controls the right channel, while /SDL controls the left channel. Driving either low disables the corresponding channel, reducing supply current to 0.03 μ A.

It is best to switch between ground and V_{DD} for minimum current consumption while in shutdown. The LM4674 may be disabled with shutdown voltages in between GND and V_{DD} , the idle current will be greater than the typical 0.03 μ A value. Increased THD+N may also be observed when a voltage of less than V_{DD} is applied to /SD_ for logic levels between GND and V_{DD} Bypass /SD_ with a 0.1 μ F capacitor.

The LM4674 shutdown inputs have internal pulldown resistors. The purpose of these resistors is to eliminate any

unwanted state changes when /SD_ is floating. To minimize shutdown current, /SD_ should be driven to GND or left floating. If /SD_ is not driven to GND or floating, an increase in shutdown supply current will be noticed.

SINGLE-ENDED AUDIO AMPLIFIER CONFIGURATION

The LM4674 is compatible with single-ended sources. When configured for single-ended inputs, input capacitors must be used to block and DC component at the input of the device. Figure 3 shows the typical single-ended applications circuit.

AUDIO AMPLIFIER POWER SUPPLY BYPASSING/FILTERING

Proper power supply bypassing is critical for low noise performance and high PSRR. Place the supply bypass capacitor as close to the device as possible. Typical applications employ a voltage regulator with 10 μ F and 0.1 μ F bypass capacitors that increase supply stability. These capacitors do not eliminate the need for bypassing of the LM4674 supply pins. A 1 μ F capacitor is recommended.

AUDIO AMPLIFIER INPUT CAPACITOR SELECTION

Input capacitors may be required for some applications, or when the audio source is single-ended. Input capacitors block the DC component of the audio signal, eliminating any conflict between the DC component of the audio source and the bias voltage of the LM4674. The input capacitors create a high-pass filter with the input resistors RI. The -3dB point of the high pass filter is found using Equation 1 below.

$$f = 1 / 2\pi R_{IN} C_{IN} \quad (1)$$

The values for RI can be found in the EC table for each gain setting.

The input capacitors can also be used to remove low frequency content from the audio signal. Small speakers cannot reproduce, and may even be damaged by low frequencies. High pass filtering the audio signal helps protect the speakers. When the LM4674 is using a single-ended source, power supply noise on the ground is seen as an input signal. Setting the high-pass filter point above the power supply noise frequencies, 217Hz in a GSM phone, for example, filters out the noise such that it is not amplified and heard on the output. Capacitors with a tolerance of 10% or better are recommended for impedance matching and improved CMRR and PSRR.

AUDIO AMPLIFIER GAIN SETTING

The LM4674 features four internally configured gain settings. The device gain is selected through the two logic inputs, G0 and G1. The gain settings are as shown in the following table.

G1	G0	GAIN	
		V/V	dB
0	0	2	6
0	1	4	12
1	0	8	18
1	1	16	24

Application Information (Continued)

PCB LAYOUT GUIDELINES

As output power increases, interconnect resistance (PCB traces and wires) between the amplifier, load and power supply create a voltage drop. The voltage loss due to the traces between the LM4674 and the load results in lower output power and decreased efficiency. Higher trace resistance between the supply and the LM4674 has the same effect as a poorly regulated supply, increasing ripple on the supply line, and reducing peak output power. The effects of residual trace resistance increases as output current increases due to higher output power, decreased load impedance or both. To maintain the highest output voltage swing and corresponding peak output power, the PCB traces that connect the output pins to the load and the supply pins to the power supply should be as wide as possible to minimize trace resistance.

The use of power and ground planes will give the best THD+N performance. In addition to reducing trace resistance, the use of power planes creates parasitic capacitors that help to filter the power supply line.

The inductive nature of the transducer load can also result in overshoot on one of both edges, clamped by the parasitic diodes to GND and VDD in each case. From an EMI standpoint, this is an aggressive waveform that can radiate or conduct to other components in the system and cause interference. It is essential to keep the power and output traces short and well shielded if possible. Use of ground planes beads and micro-strip layout techniques are all useful in preventing unwanted interference.

As the distance from the LM4674 and the speaker increases, the amount of EMI radiation increases due to the output wires or traces acting as antennas become more efficient with length. Ferrite chip inductors placed close to the LM4674 outputs may be needed to reduce EMI radiation.

Application Information (Continued)

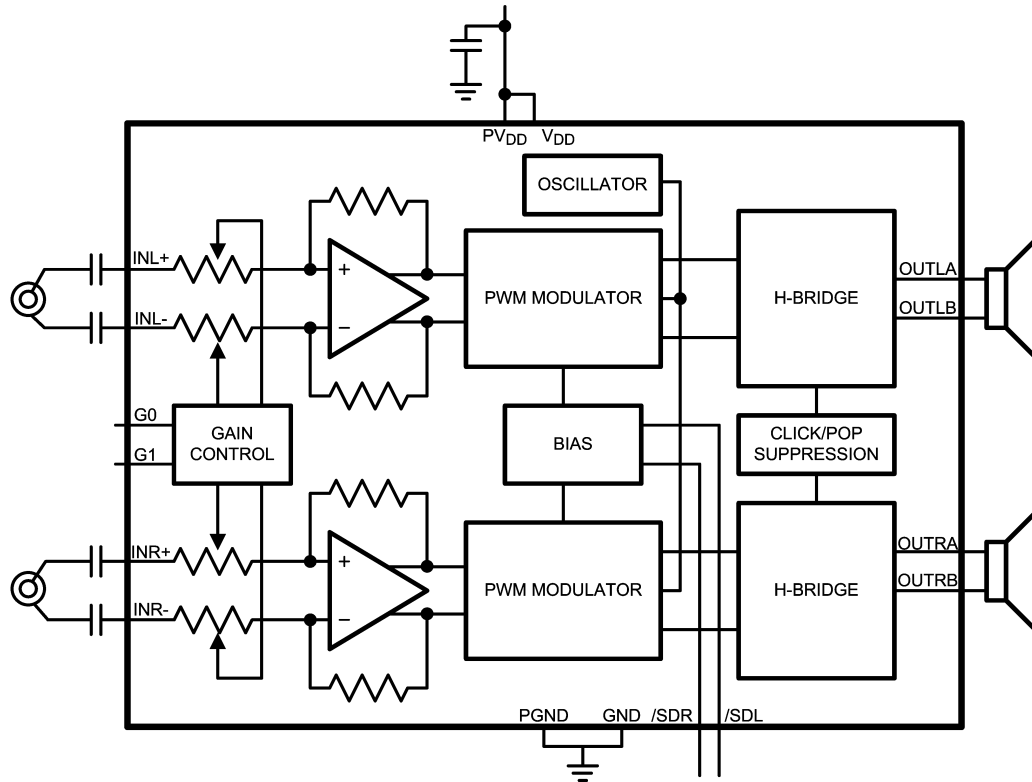

20167426

Differential Input Configuration

FIGURE 2.

Application Information (Continued)

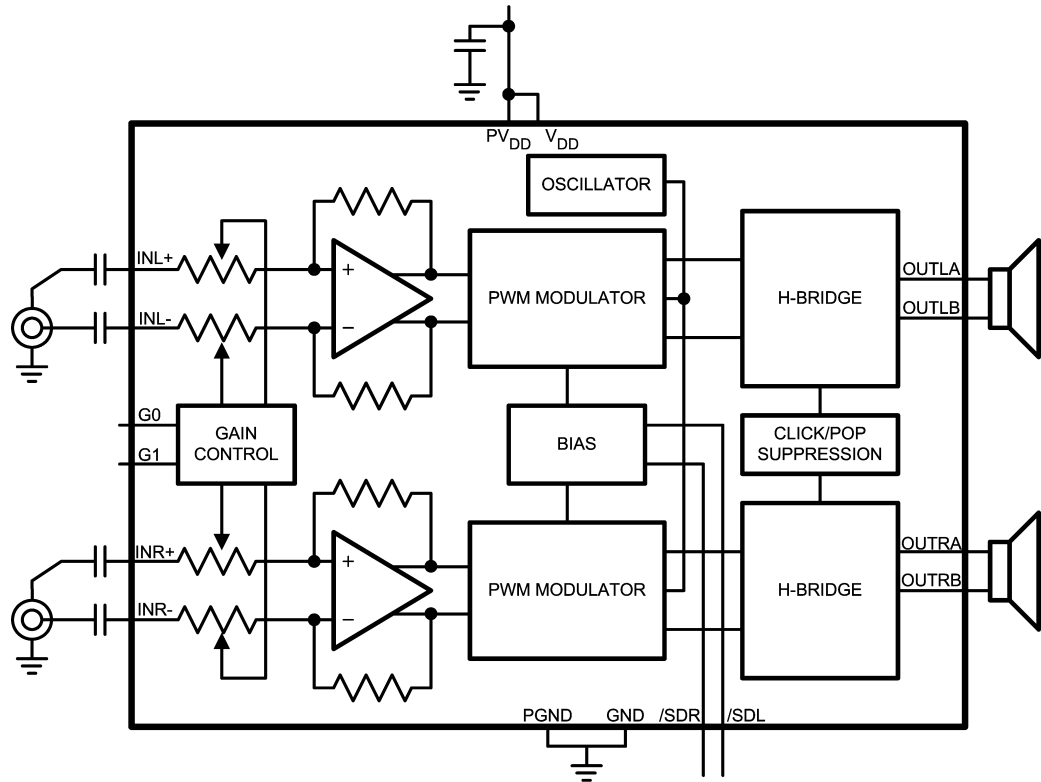

Single-Ended Input Configuration

20167438

FIGURE 3.

Revision Table

Rev	Date	Description
1.0	10/4/05	1st PDF edited after copied LM4671.
1.1	12/15/05	Added graphics 22, 23, and 24. Also did some texts edits.
1.2	12/16/05	Edited 201674 23, then released D/S to the WEB.

Physical Dimensions inches (millimeters) unless otherwise noted

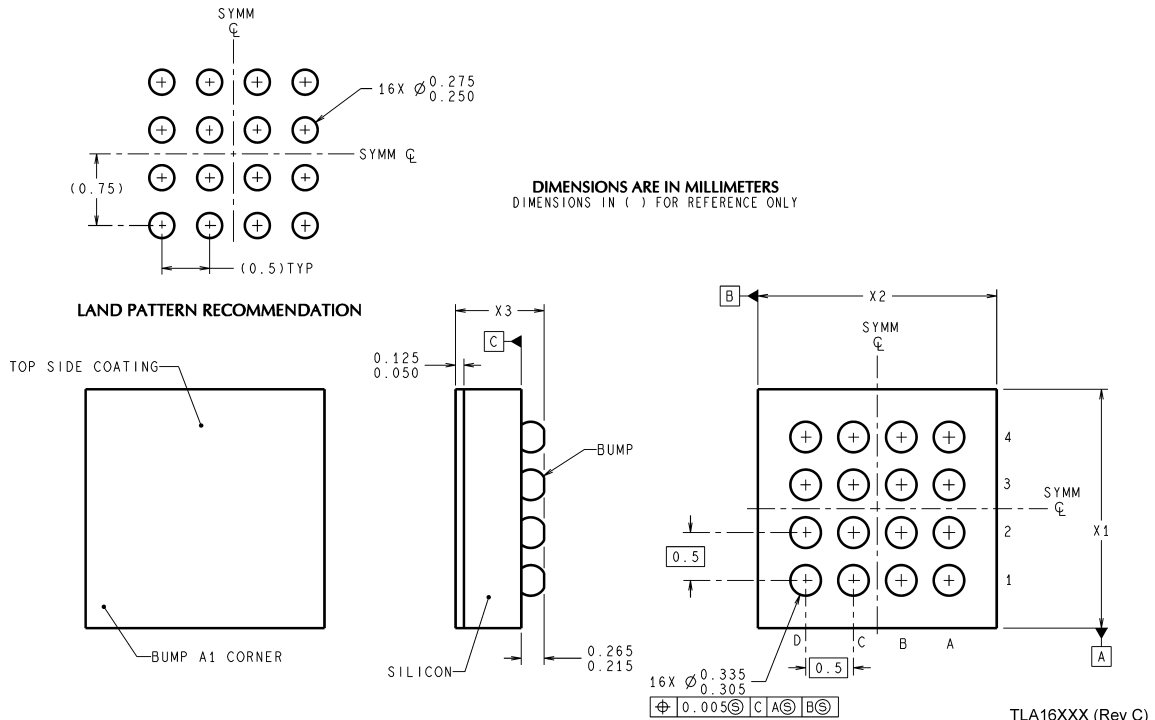

16 Bump micro SMD
Order Number LM4674TL
NS Package Number TLA1611A
X1 = 2mm X2 = 2mm X3 = 0.6mm

National does not assume any responsibility for use of any circuitry described, no circuit patent licenses are implied and National reserves the right at any time without notice to change said circuitry and specifications.

For the most current product information visit us at www.national.com.

LIFE SUPPORT POLICY

NATIONAL'S PRODUCTS ARE NOT AUTHORIZED FOR USE AS CRITICAL COMPONENTS IN LIFE SUPPORT DEVICES OR SYSTEMS WITHOUT THE EXPRESS WRITTEN APPROVAL OF THE PRESIDENT AND GENERAL COUNSEL OF NATIONAL SEMICONDUCTOR CORPORATION. As used herein:

1. Life support devices or systems are devices or systems which, (a) are intended for surgical implant into the body, or (b) support or sustain life, and whose failure to perform when properly used in accordance with instructions for use provided in the labeling, can be reasonably expected to result in a significant injury to the user.
2. A critical component is any component of a life support device or system whose failure to perform can be reasonably expected to cause the failure of the life support device or system, or to affect its safety or effectiveness.

BANNED SUBSTANCE COMPLIANCE

National Semiconductor manufactures products and uses packing materials that meet the provisions of the Customer Products Stewardship Specification (CSP-9-111C2) and the Banned Substances and Materials of Interest Specification (CSP-9-111S2) and contain no "Banned Substances" as defined in CSP-9-111S2.

Leadfree products are RoHS compliant.



National Semiconductor
Americas Customer Support Center
 Email: new.feedback@nsc.com
 Tel: 1-800-272-9959

National Semiconductor
Europe Customer Support Center
 Fax: +49 (0) 180-530 85 86
 Email: europa.support@nsc.com
 Deutsch Tel: +49 (0) 69 9508 6208
 English Tel: +44 (0) 870 24 0 2171
 Français Tel: +33 (0) 1 41 91 8790

National Semiconductor
Asia Pacific Customer Support Center
 Email: ap.support@nsc.com

National Semiconductor
Japan Customer Support Center
 Fax: 81-3-5639-7507
 Email: jpn.feedback@nsc.com
 Tel: 81-3-5639-7560