

DUAL BRIDGE DRIVER

KA8306 is dual bridge driver designed for the cassette and tape loading motor drives in a VCR system.

FEATURES

- 4 modes available (CW/CCW/STOP/BRAKE)
- Output current up to 1.0A (AVE) and 1.5A (PEAK)
- Wide range of operating voltage
 $V_{CC\text{ opr}} = 4.5 \sim 18V$
 $V_S\text{ opr} = 0 \sim 18V$
 $V_{REF\text{ opr}} = 0 \sim 18V$
- Build in thermal shutdown, over current protector and punch through current restriction circuit.
- Hysteresis for all inputs.

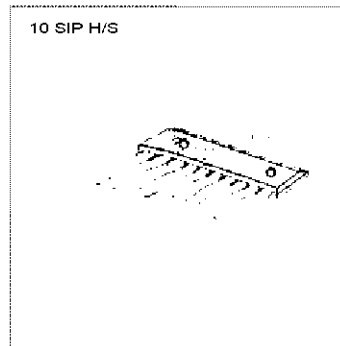

ORDERING INFORMATION

Device	Package	Operating Temperature
KA8306	10 SIP H/S	-30 ~ +75 °C

ABSOLUTE MAXIMUM RATINGS (T_A = 25°C)

Characteristic	Symbol	Value	Unit
Supply Voltage	V _{CC}	25	V
Motor Drive Voltage	V _S	25	V
Reference Voltage	V _{REF}	25	V
Output Current	I _O (peak)	1.5	A
	I _O (AVE)	1.0	A
Power Dissipation	P _D	7.0	W
Operating Temperature	T _{OPR}	-30 ~ +75	°C
Storage Temperature	T _{STG}	-55 ~ +150	°C

BLOCK DIAGRAM

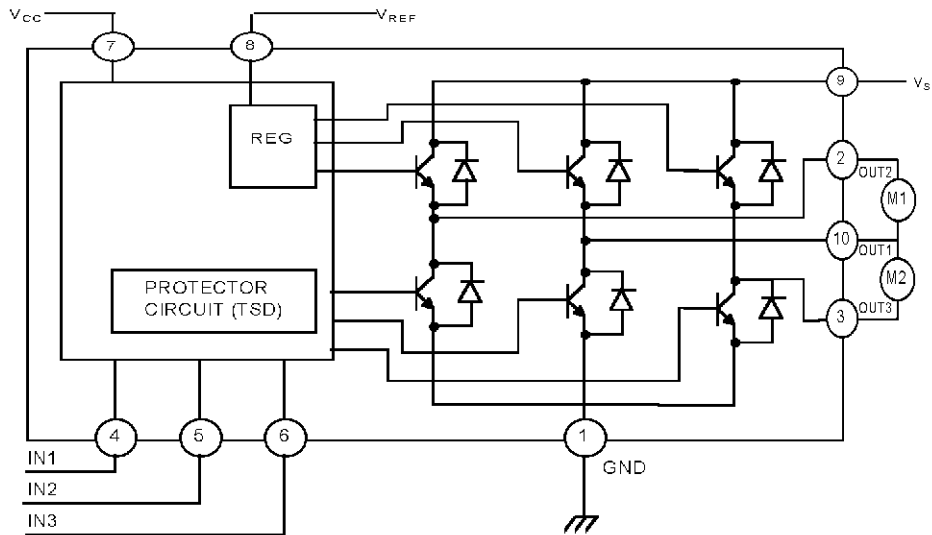

INPUT*			OUTPUT			MODE	
IN1	IN2	IN3	OUT1	OUT2	OUT3	M1	M2
0	0	1/0	L	L	L	BRAKE	BRAKE
1	0	0	H	L	**	CW/CCW	STOP
1	0	1	L	H	**	CCW/CW	STOP
0	1	0	H	**	L	STOP	CW/CCW
0	1	1	L	**	H	STOP	CCW/CW
1	1	1/0	L	L	L	BRAKE	BRAKE

*: Inputs are all high active type

** High impedance

ELECTRICAL CHARACTERISTICS ($T_A=25^\circ\text{C}$, $V_{CC}=18\text{V}$, $V_S=18\text{V}$)

Characteristic		Symbol	Test Circuit	Test Conditions	Min	Typ	Max	Unit
Supply Current		I_{CC1}	1	Output Off CW/CCW Mode	—	17	30	mA
		I_{CC2}	1	Output Off, Stop Mode	—	13	25	mA
Input Operating Voltage	H	V_{IN-H}	2	$T_J=25^\circ\text{C}$	3.5	—	5.5	V
	L	V_{IN-L}	2	$T_J=25^\circ\text{C}$	0	—	0.8	V
Input Current		I_{IN}	2	$V_{IN}=3.5\text{V}$, Sink Mode	—	5	20	μA
Input Hysteresis Voltage		V_{HYS}	2		—	0.7	—	V
Saturation Voltage	Upper	V_{SAT-1U}	3	$V_{REF}=V_S$, $I_O=0.2\text{A}$	—	1.2	1.5	V
	Lower	V_{SAT-1L}	3	$V_{REF}=V_S$, $I_O=0.2\text{A}$	—	1.1	1.4	V
	Upper	V_{SAT-2U}	3	$V_{REF}=V_S$, $I_O=1.0\text{A}$	—	2.7	3.1	V
	Lower	V_{SAT-2L}	3	$V_{REF}=V_S$, $I_O=1.0\text{A}$	—	2.5	3.0	V
Output Voltage		V_O-1	3	$V_{REF}=10\text{V}$, $I_O=0.5\text{A}$ Output Measure	10.3	10.7	11.5	V
		V_O-2	3	$V_{REF}=10\text{V}$, $I_O=0.5\text{A}$ Output Measure	10.1	10.5	11.3	V
Leakage Current	Upper	I_{L-U}		$V_S=25\text{V}$	—	0	50	μA
	Lower	I_{L-L}		$V_S=25\text{V}$	—	0	50	μA
Diode Forward Voltage	Upper	V_F-U	4	$I_F=1.0\text{A}$	—	2.2	—	V
	Lower	V_F-L	4	$I_F=1.0\text{A}$	—	1.4	—	V
Reference Current		I_{REF}	2	$V_{REF}=10\text{V}$, Source Mode	—	20	30	μA

TEST CIRCUIT 1

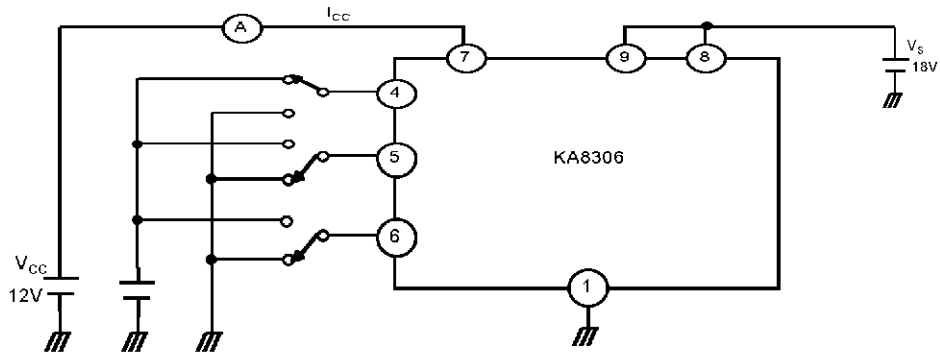

TEST CIRCUIT 2

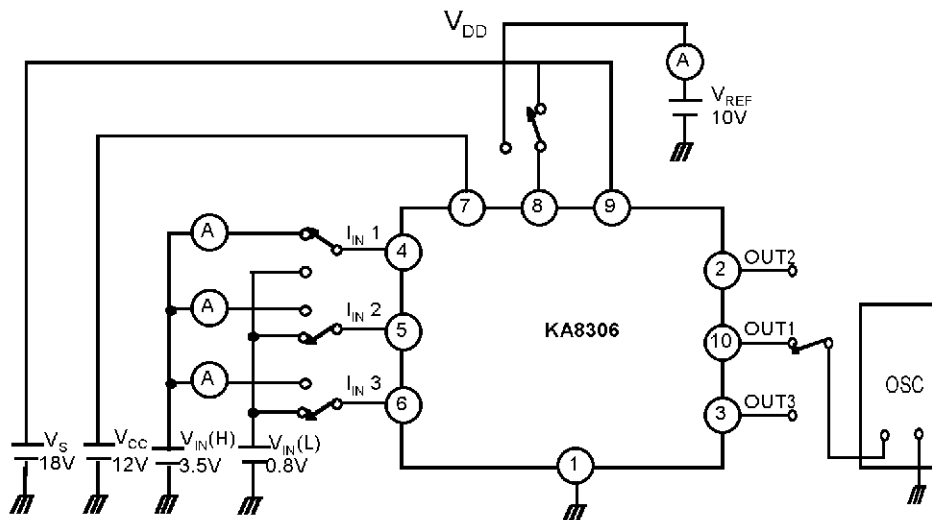

TEST CIRCUIT 3

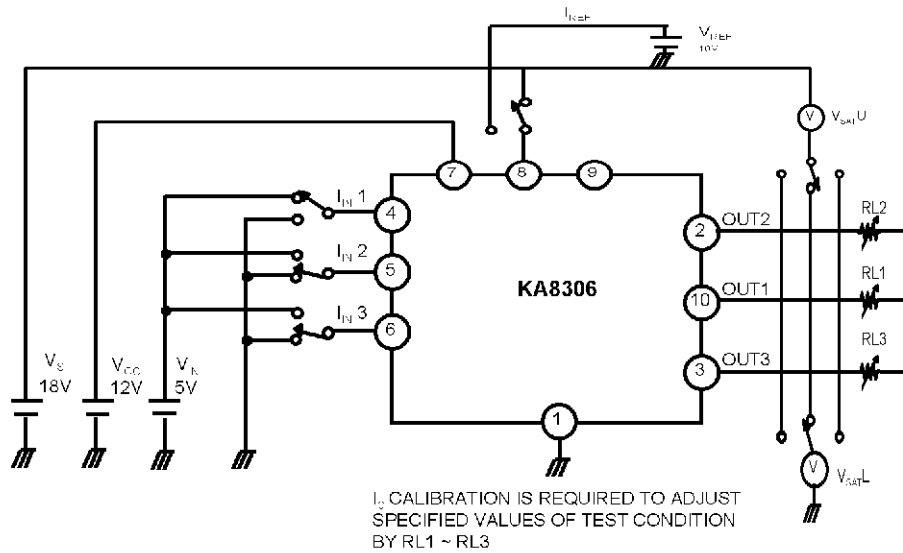

TEST CIRCUIT 4

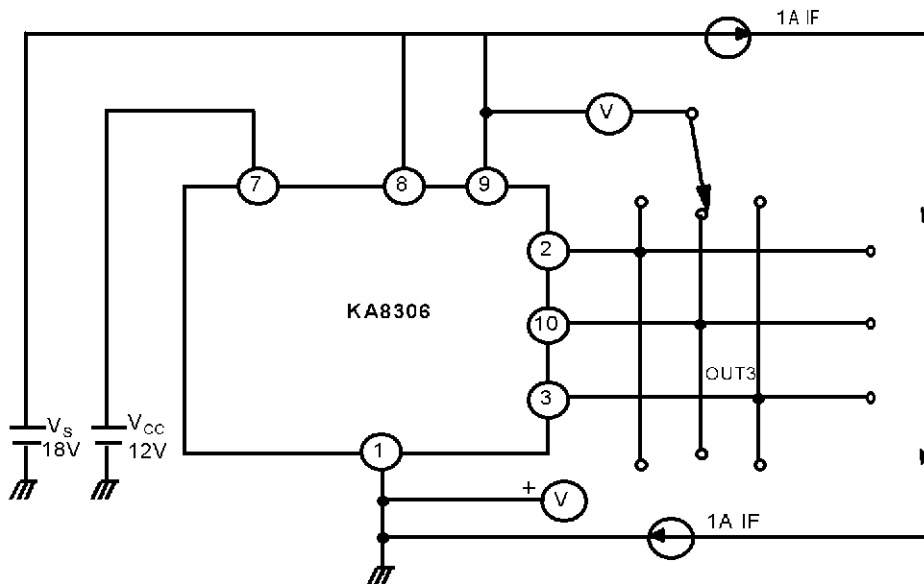

APPLICATION CIRCUIT

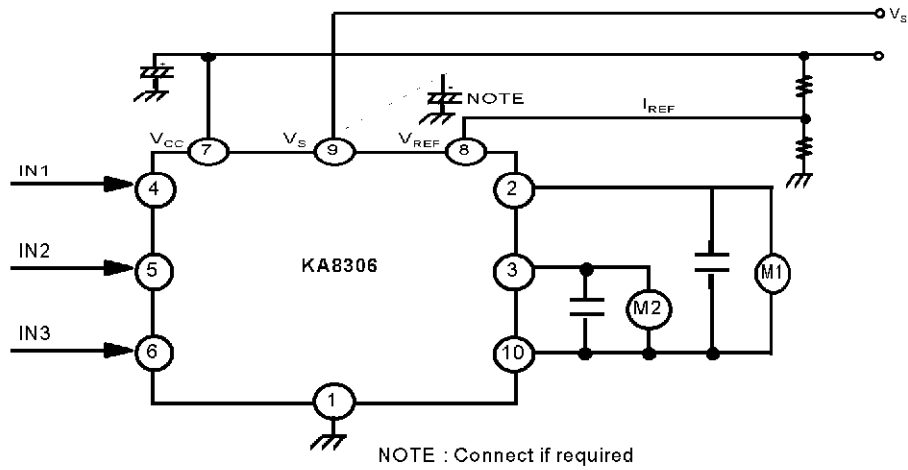

INPUT CIRCUIT

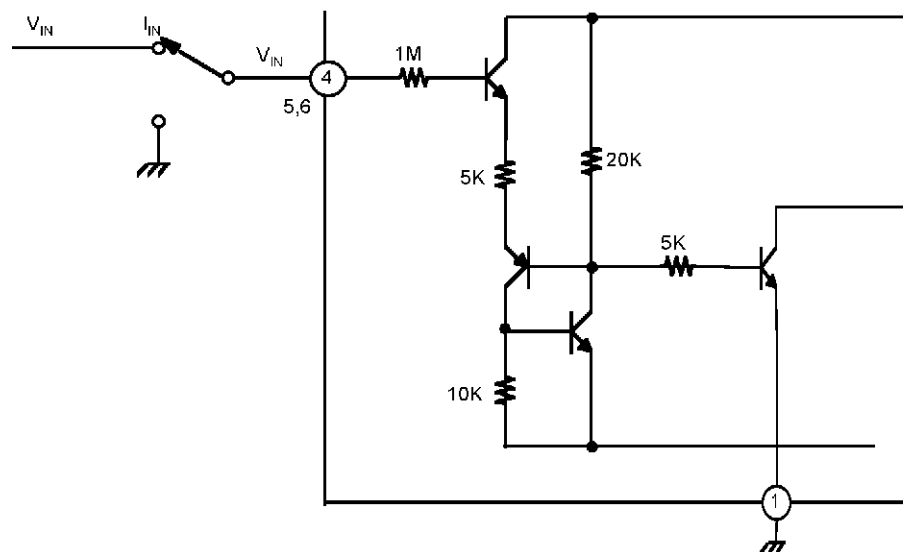

INPUT TERMINALS OF PINS 4,5 AND 6 ARE ALL HIGH ACTIVE TYPE AND HAVE A HYSTERESIS OF 0.7V TYPE $5\mu\text{A}$ TYPE OF SOURCE MODE INPUT CURRENT IS REQUIRED.

OUTPUT CIRCUIT

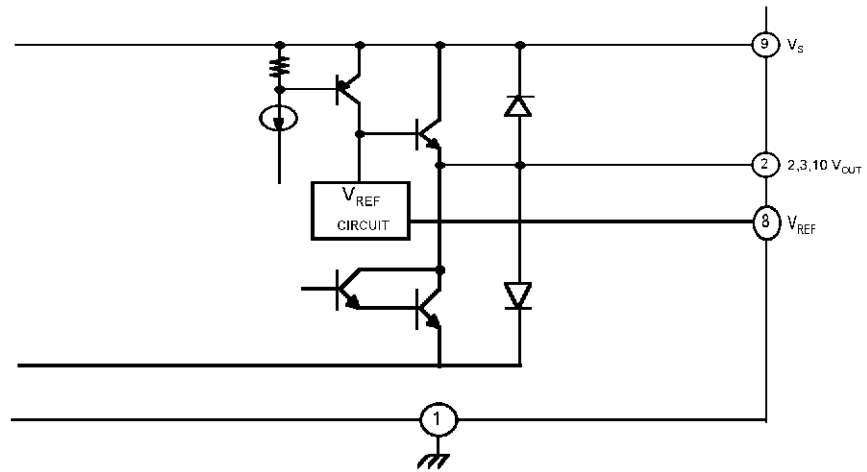

OUTPUT VOLTAGE IS CONTROLLED BY V_{REF} VOLTAGE RELATIONSHIP BETWEEN V_{OUT} AND V_{REF} IS $V_{OUT} = V_{BE} (= 0.7) + V_{REF}$
 V_{REF} TERMINAL REQUIRED TO CONNECT TO V_S TERMINAL FOR STABLE OPERATION IN CASE OF NO REQUIREMENT OF V_{OUT} CONTROL

Dimensions in Millimeters

