

# TPS60110 REGULATED 5-V 300-mA LOW-NOISE CHARGE PUMP DC/DC CONVERTER

SLVS215A – JUNE 1999 – REVISED SEPTEMBER 1999

## features

- Up to 300-mA Output Current
- Less Than 10-mV<sub>pp</sub> Output Voltage Ripple
- No Inductors Required/Low EMI
- Regulated 5-V ±4% Output
- Only Four External Components Required
- Up to 90% Efficiency
- 2.7-V to 5.4-V Input Voltage Range
- 60-μA Quiescent Supply Current
- 0.05-μA Shutdown Current
- Load Isolated in Shutdown
- Space-Saving Thermally-Enhanced TSSOP PowerPAD™ Package
- Evaluation Module Available (TPS60110EVM-132)

## description

The TPS60110 step-up, regulated charge pump generates a 5-V ±4% output voltage from a 2.7-V to 5.4-V input voltage (three alkaline, NiCd, or NiMH batteries; or, one lithium or lithium ion battery). Output current is 300 mA from a 3-V input. Only four external capacitors are needed to build a complete low-noise dc/dc converter. The push-pull operating mode of two single-ended charge pumps assures the low output voltage ripple as current is continuously transferred to the output. From a 3-V input, the TPS60110 can start into full load with loads as low as 16 Ω.

The TPS60110 features either constant frequency mode to minimize noise and output voltage ripple or the power-saving pulse-skip mode to extend battery life at light loads. The TPS60110 switching frequency is 300 kHz. The logic shutdown function reduces the supply current to 1-μA (max) and disconnects the load from the input. Special current-control circuitry prevents excessive current from being drawn from the battery during start-up. This dc/dc converter requires no inductors and has low EMI. It is available in the small 20-pin TSSOP PowerPAD™ package (PWP).

## applications

Replaces DC/DC Converters With Inductors in

- Battery-Powered Applications
- Li-Ion Battery to 5-V Conversion
- Portable Instruments
- Battery-Powered Microprocessor Systems
- Miniature Equipment
- Backup-Battery Boost Converters
- PDAs
- Laptops
- Handheld Instrumentation
- Medical Instruments

## output voltage ripple

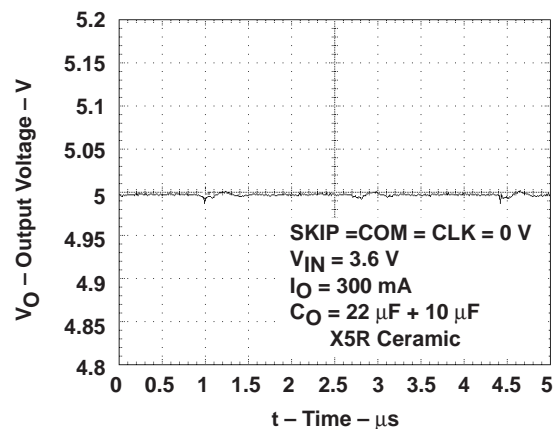

## typical operating circuit

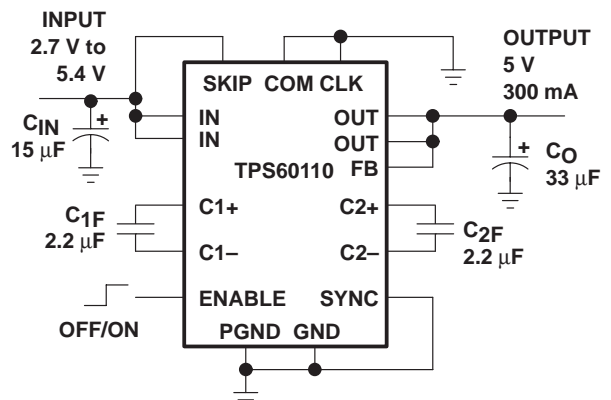

Figure 1



Please be aware that an important notice concerning availability, standard warranty, and use in critical applications of Texas Instruments semiconductor products and disclaimers thereto appears at the end of this data sheet.

PowerPAD is a trademark of Texas Instruments Incorporated.

PRODUCTION DATA information is current as of publication date. Products conform to specifications per the terms of Texas Instruments standard warranty. Production processing does not necessarily include testing of all parameters.

**TEXAS  
INSTRUMENTS**

POST OFFICE BOX 655303 • DALLAS, TEXAS 75265

Copyright © 1999, Texas Instruments Incorporated

# TPS60110 REGULATED 5-V 300-mA LOW-NOISE CHARGE PUMP DC/DC CONVERTER

SLVS215A – JUNE 1999 – REVISED SEPTEMBER 1999

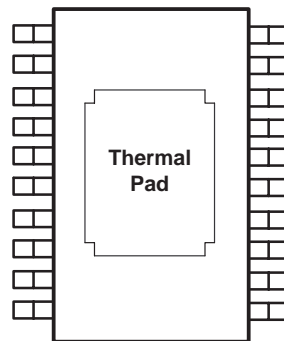
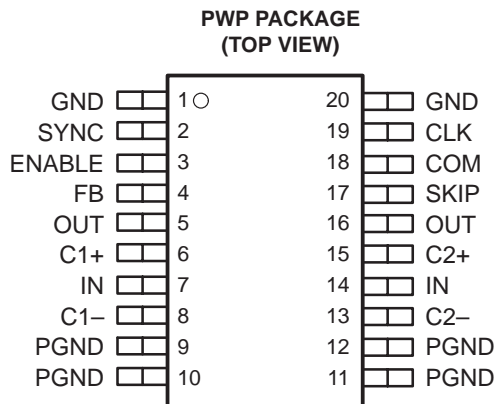

**Figure 2. Bottom View of PWP Package, Showing the Thermal Pad**

### AVAILABLE OPTIONS

<b>PACKAGE</b>
<b>TSSOP<sup>†</sup> (PWP)</b>
TPS60110PWP

<sup>†</sup> This package is available taped and reeled. To order this packaging option, add an R suffix to the part number (e.g., TPS60110PWPR).

### Terminal Functions

TERMINAL NAME	NO.	I/O	DESCRIPTION
CLK	19	I	Input for external clock signal. If the internal clock is used, connect this terminal to GND.
C1+	6		Positive terminal of the charge-pump capacitor C <sub>1F</sub>
C1-	8		Negative terminal of the charge-pump capacitor C <sub>1F</sub>
C2+	15		Positive terminal of the charge-pump capacitor C <sub>2F</sub>
C2-	13		Negative terminal of the charge-pump capacitor C <sub>2F</sub>
COM	18	I	Mode selection. When COM is logic low the charge pump operates in push-pull mode to minimize output ripple. When COM is connected to IN the regulator operates in single-ended mode requiring only one flying capacitor.
ENABLE	3	I	ENABLE Input. The device turns off, the output disconnects from the input, and the supply current decreases to 0.05 $\mu$ A when ENABLE is a logic low. Connect ENABLE to IN for normal operation.
FB	4	I	FEEDBACK input. Connect FB to OUT as close to the load as possible to achieve best regulation. Resistive divider is on-chip to match internal reference voltage of 1.22 V.
GND	1, 20		GROUND. Analog ground for internal reference and control circuitry. Connect to PGND through a short trace.
IN	7, 14	I	Supply Input. Connect to an input supply in the 2.7-V to 5.4-V range. Bypass IN to GND with a (C <sub>O</sub> /2) $\mu$ F capacitor. Connect both INs through a short trace.
OUT	5, 16	O	Regulated 5-V power output. Connect both OUTs through a short trace and bypass OUT to GND with the output filter capacitor C <sub>O</sub> .
PGND	9–12		PGND power ground. Charge-pump current flows through this pin. Connect all PGNDs together.
SKIP	17	I	Mode selection. When SKIP is logic low, the charge pump operates in constant-frequency mode. Output ripple and noise are minimized in this mode. When SKIP is connect to IN, the device operates in pulse skip mode. Quiescent current is lowest in this mode.
SYNC	2	I	Selection for external clock signal. Connect to GND to use the internally generated clock signal. Connect to IN for external synchronization. In this case, the clock signal needs to be fed through CLK.

**absolute maximum ratings (unless otherwise noted)†‡**

Input voltage range, $V_I$ (IN, OUT, ENABLE, SKIP, COM, CLK, FB, SYNC)	.....	-0.3 V to 5.5 V
Differential input voltage, $V_{ID}$ (C1+, C2+ to GND)	.....	-0.3 V to ( $V_O + 0.3$ V)
Differential input voltage, $V_{ID}$ (C1-, C2- to GND)	.....	-0.3 V to ( $V_{IN} + 0.3$ V)
Continuous total power dissipation	.....	See Dissipation Rating Tables
Continuous output current	.....	400 mA
Storage temperature range, $T_{stg}$	.....	-55°C to 150°C
Lead temperature 1,6 mm (1/16 inch) from case for 10s	.....	260°C
Maximum junction temperature, $T_J$	.....	150°C

† Stresses beyond those listed under “absolute maximum ratings” may cause permanent damage to the device. These are stress ratings only, and functional operation of the device at these or any other conditions beyond those indicated under “recommended operating conditions” is not implied. Exposure to absolute-maximum-rated conditions for extended periods may affect device reliability.

‡  $V_{ENABLE}$ ,  $V_{SKIP}$ ,  $V_{COM}$ ,  $V_{CLK}$  and  $V_{SYNC}$  can exceed  $V_{IN}$  up to the maximum rated voltage without increasing the leakage current drawn by these mode select inputs.

**DISSIPATION RATING TABLE 1 – FREE-AIR TEMPERATURE (see Figure 3)**

PACKAGE	$T_A \leq 25^\circ\text{C}$ POWER RATING	DERATING FACTOR ABOVE $T_A = 25^\circ\text{C}$	$T_A = 70^\circ\text{C}$ POWER RATING	$T_A = 85^\circ\text{C}$ POWER RATING
PWP	700 mW	5.6 mW/°C	448 mW	364 mW

**DISSIPATION RATING TABLE 2 – CASE TEMPERATURE (see Figure 4)**

PACKAGE	$T_C \leq 62.5^\circ\text{C}$ POWER RATING	DERATING FACTOR ABOVE $T_C = 62.5^\circ\text{C}$	$T_C = 70^\circ\text{C}$ POWER RATING	$T_C = 85^\circ\text{C}$ POWER RATING
PWP	25 W	285.7 mW/°C	22.9 W	18.5 W

**DISSIPATION DERATING CURVES§  
 vs  
 FREE-AIR TEMPERATURE**

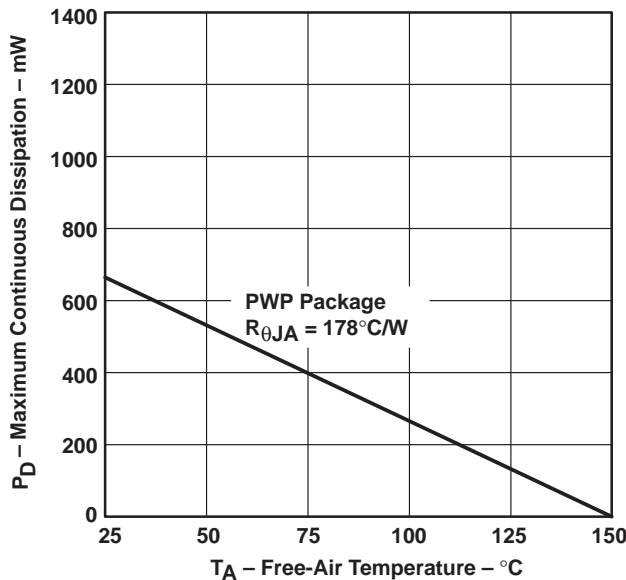

**Figure 3**

**MAXIMUM CONTINUOUS DISSIPATION§  
 vs  
 CASE TEMPERATURE**

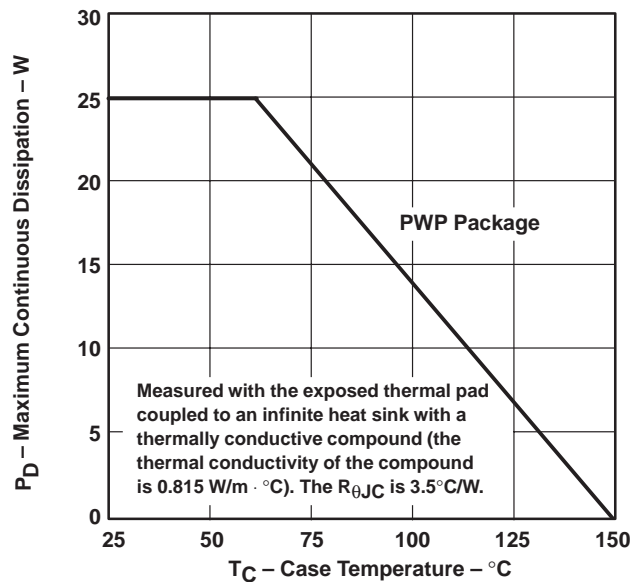

**Figure 4**

§ Dissipation rating tables and figures are provided for maintenance of junction temperature at or below absolute maximum temperature of 150°C. It is recommended not to exceed a junction temperature of 125°C.

**TPS60110**  
**REGULATED 5-V 300-mA LOW-NOISE**  
**CHARGE PUMP DC/DC CONVERTER**

SLVS215A – JUNE 1999 – REVISED SEPTEMBER 1999

electrical characteristics at  $C_{IN} = 15 \mu\text{F}$ ,  $C_{1F} = C_{2F} = 2.2 \mu\text{F}^\dagger$ ,  $C_O = 33 \mu\text{F}$ ,  $T_C = -40^\circ\text{C}$  to  $85^\circ\text{C}$ ,  $V_{IN} = 3\text{V}$ ,  $V_{FB} = V_O$ ,  $V_{ENABLE} = V_{IN}$ ,  $V_{SKIP} = V_{IN}$  or  $0\text{V}$  and  $V_{COM} = V_{CLK} = V_{SYNC} = 0\text{V}$  (unless otherwise noted)

PARAMETER	TEST CONDITIONS	MIN	TYP	MAX	UNIT
$V_{IN}$ Input voltage		2.7		5.4	V
$I_{O(MAX)}$ Maximum output current		300			mA
$V_O$ Output voltage	$2.7\text{V} < V_{IN} < 3\text{V}$ , $V_{O(Start-Up)} = 5\text{V}$ , $T_C = 25^\circ\text{C}$	4.8	5	5.2	V
	$3\text{V} < V_{IN} < 5\text{V}$ , $0 < I_O < 300\text{mA}$	4.8	5	5.2	
	$5\text{V} < V_{IN} < 5.4\text{V}$ , $0 < I_O < 300\text{mA}$	4.8	5	5.25	
$V_{O(RIP)}$ Output voltage ripple	$I_O = 300\text{mA}$ , $V_{SKIP} = 0\text{V}$		10 $\ddagger$		mV <sub>PP</sub>
$I_{O(LEAK)}$ Output leakage current	$V_{IN} = 3.6\text{V}$ , $V_{ENABLE} = 0\text{V}$			1	$\mu\text{A}$
$I_Q$ Quiescent current (no-load input current)	$V_{SKIP} = V_{IN} = 3.6\text{V}$		60	90	$\mu\text{A}$
	$V_{SKIP} = 0\text{V}$ , $V_{IN} = 3.6\text{V}$		2.8		mA
$I_{DD(SDN)}$ Shutdown supply current	$V_{IN} = 3.6\text{V}$ , $V_{ENABLE} = 0\text{V}$		0.05	1	$\mu\text{A}$
$f_{OSC(int)}$ Internal switching frequency	$V_{IN} = 3.6\text{V}$	200	300	400	kHz
$f_{OSC(ext)}$ External clock frequency	$V_{SYNC} = V_{IN}$ , $V_{IN} = 2.7\text{V}$ to $5.4\text{V}$	400	600	800	kHz
External clock duty cycle	$V_{SYNC} = V_{IN}$ , $V_{IN} = 2.7\text{V}$ to $5.4\text{V}$		20%	80%	
Efficiency	$I_O = 150\text{mA}$		80%		
$V_{INL}$ Input voltage low, ENABLE, SKIP, COM, CLK, SYNC	$V_{IN} = 2.7\text{V}$			$0.3 \times V_{IN}$	V
$V_{INH}$ Input voltage high, ENABLE, SKIP, COM, CLK, SYNC	$V_{IN} = 5.4\text{V}$	$0.7 \times V_{IN}$			V
$I_I(LEAK)$ Input leakage current, ENABLE, SKIP, COM, CLK, SYNC	$V_{ENABLE} = V_{SKIP} = V_{COM} = V_{CLK} =$ $V_{SYNC} = V_{GND}$ or $V_{IN}$		0.01	0.1	$\mu\text{A}$
Output load regulation	$V_O = 5\text{V}$ , $T_C = 25^\circ\text{C}$ $1\text{mA} < I_O < 300\text{mA}$		0.002		%/mA
Output line regulation	$3\text{V} < V_{IN} < 5\text{V}$ , $I_O = 150\text{mA}$ , $T_C = 25^\circ\text{C}$ $V_O = 5\text{V}$ , $T_C = 25^\circ\text{C}$		0.6		%/V
Short circuit current	$V_{IN} = 3.6\text{V}$ , $T_C = 25^\circ\text{C}$ $V_O = 0\text{V}$		150		mA

$^\dagger$  Use only ceramic capacitors with X5R or X7R dielectric as flying capacitors.

$^\ddagger$  Achieved with  $C_O = 22 \mu\text{F} + 10 \mu\text{F}$  X5R dielectric ceramic capacitor

TYPICAL CHARACTERISTICS†

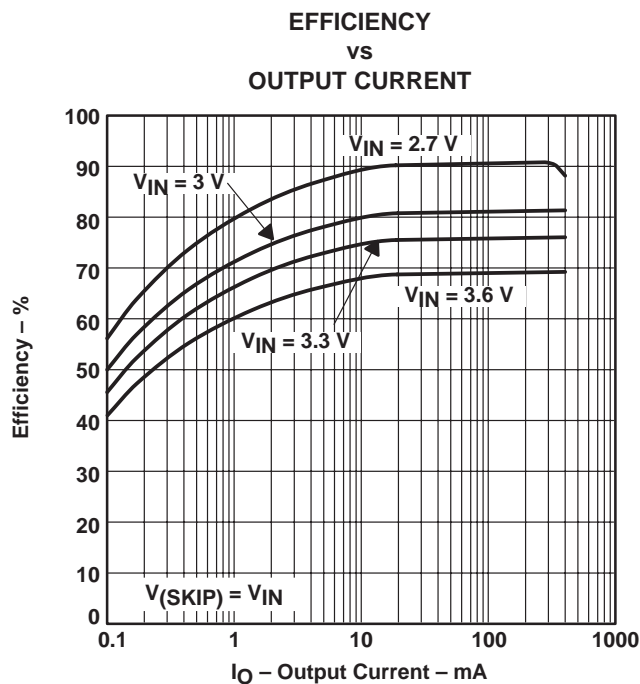

Figure 5

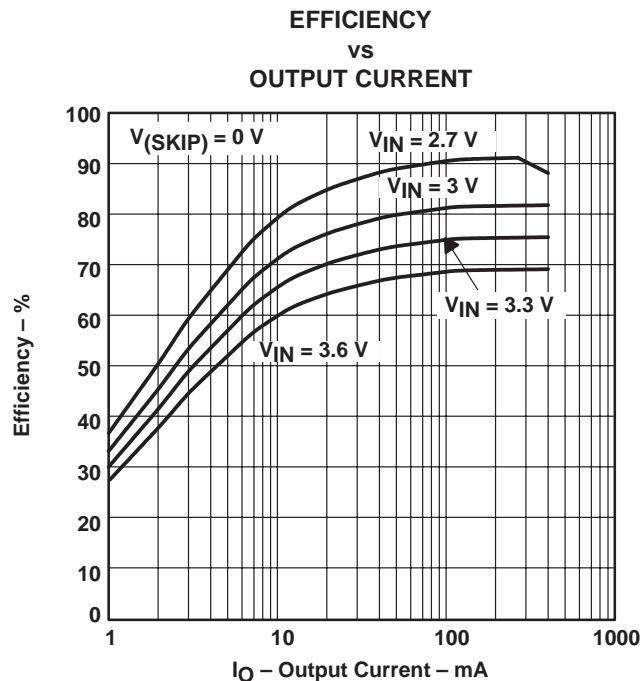

Figure 6

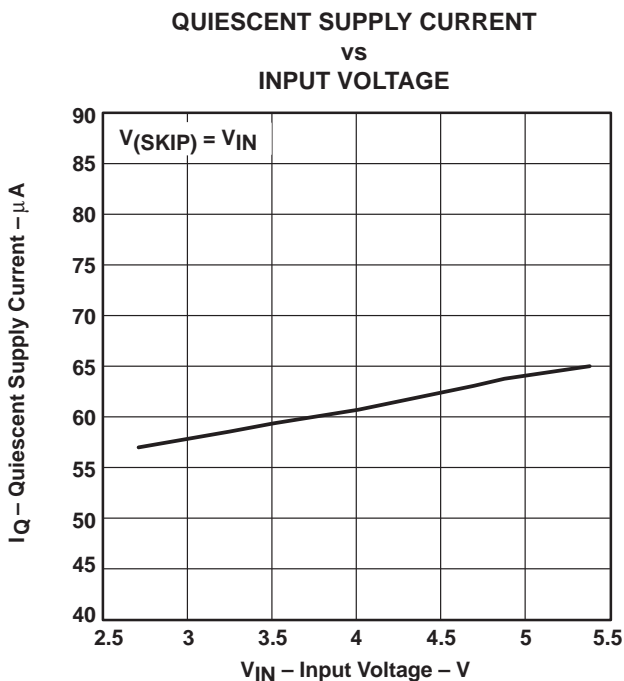

Figure 7

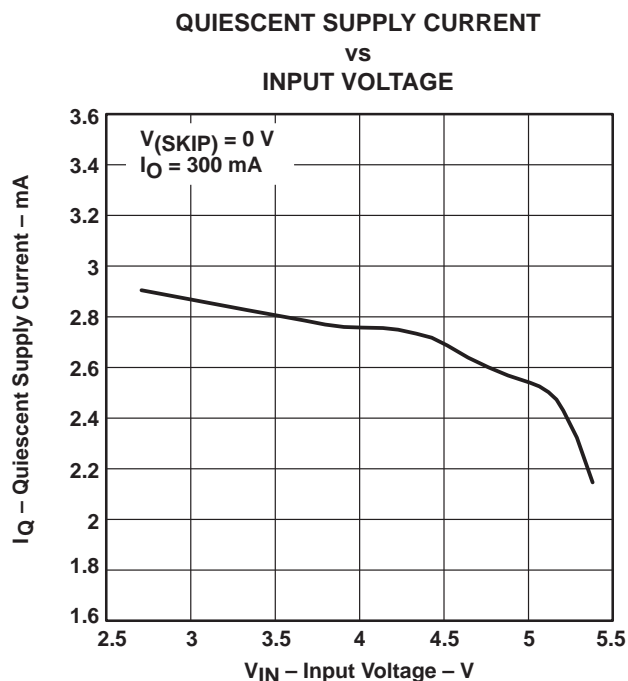

Figure 8

†  $T_C = 25^\circ\text{C}$ ,  $V_{COM} = V_{SYNC} = 0\text{ V}$ ,  $C_{IN} = 15\ \mu\text{F}$ ,  $C_{1F} = C_{2F} = 2.2\ \mu\text{F}$ ,  $C_O = 33\ \mu\text{F}$ , unless otherwise noted

**TPS60110**  
**REGULATED 5-V 300-mA LOW-NOISE**  
**CHARGE PUMP DC/DC CONVERTER**

SLVS215A – JUNE 1999 – REVISED SEPTEMBER 1999

**TYPICAL CHARACTERISTICS†**

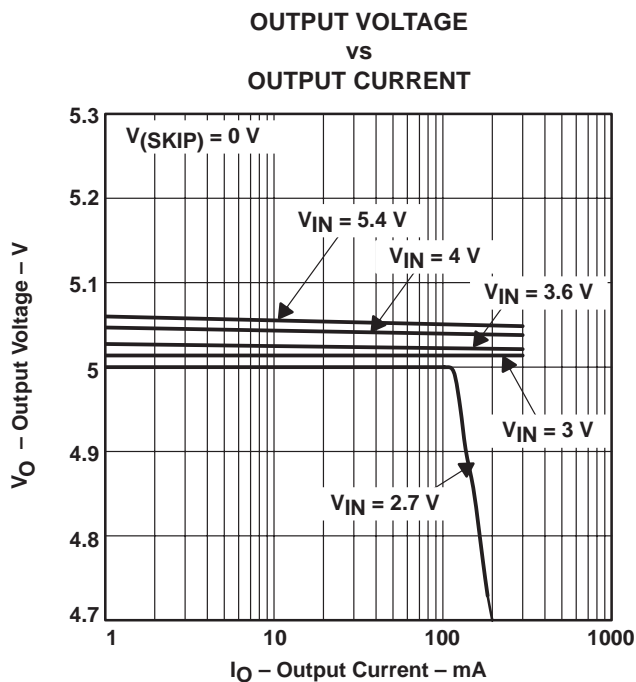

**Figure 9**

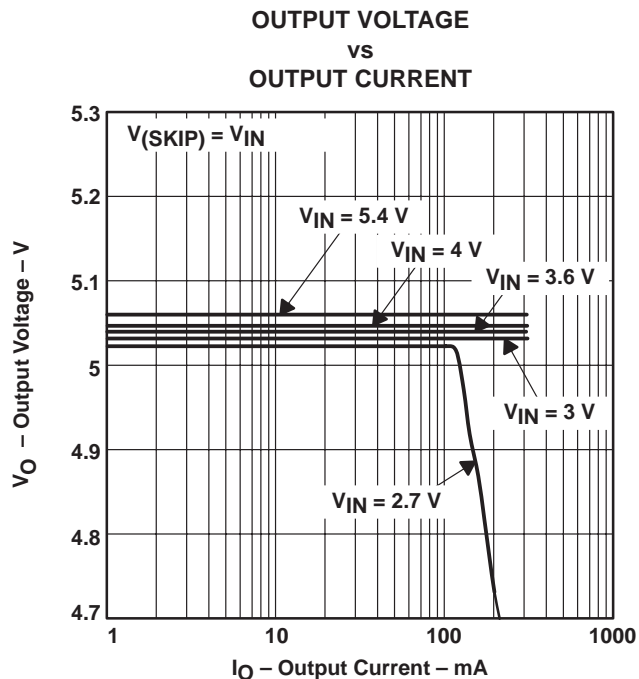

**Figure 10**

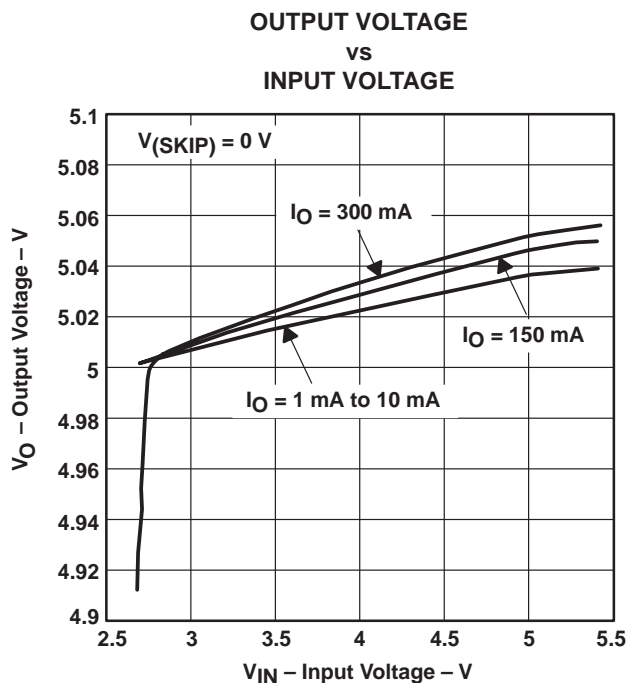

**Figure 11**

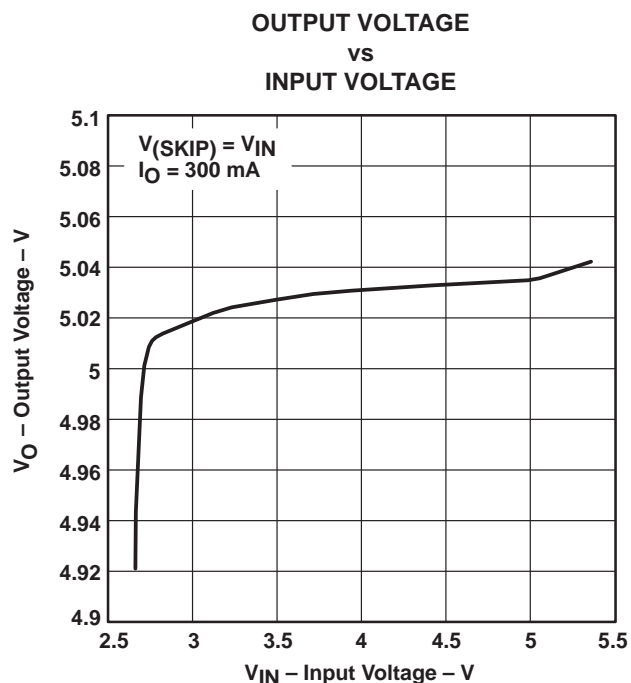

**Figure 12**

†  $T_C = 25^\circ\text{C}$ ,  $V_{\text{COM}} = V_{\text{SYNC}} = 0\text{ V}$ ,  $C_{\text{IN}} = 15\ \mu\text{F}$ ,  $C_{1\text{F}} = C_{2\text{F}} = 2.2\ \mu\text{F}$ ,  $C_{\text{O}} = 33\ \mu\text{F}$ , unless otherwise noted

TYPICAL CHARACTERISTICS†

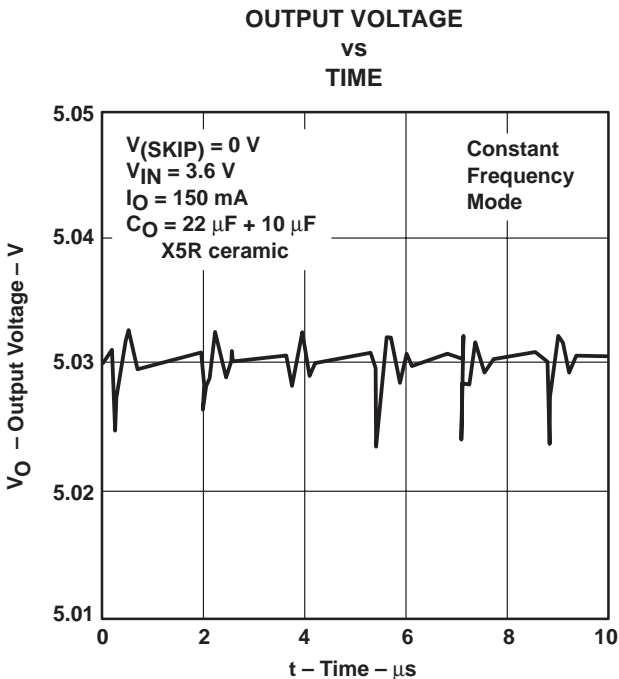

Figure 13

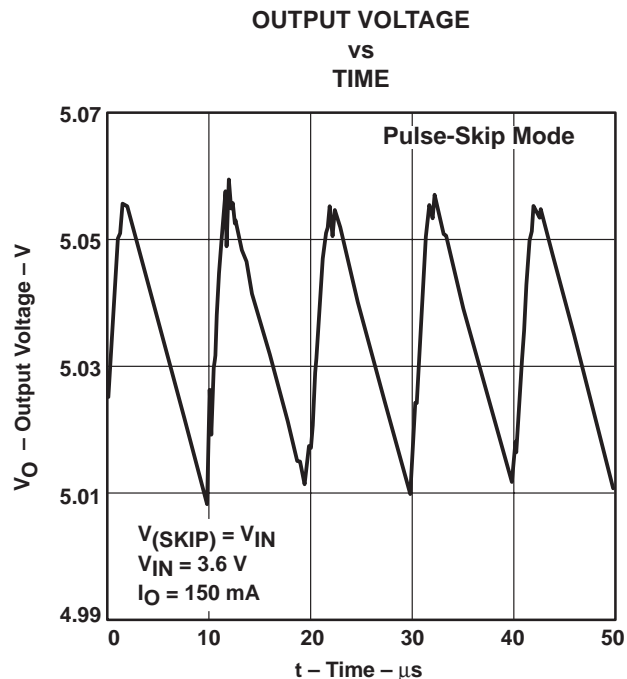

Figure 14

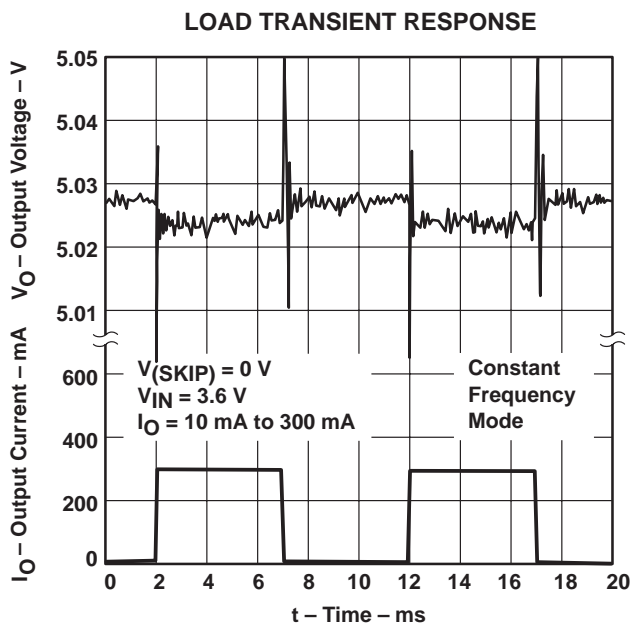

Figure 15

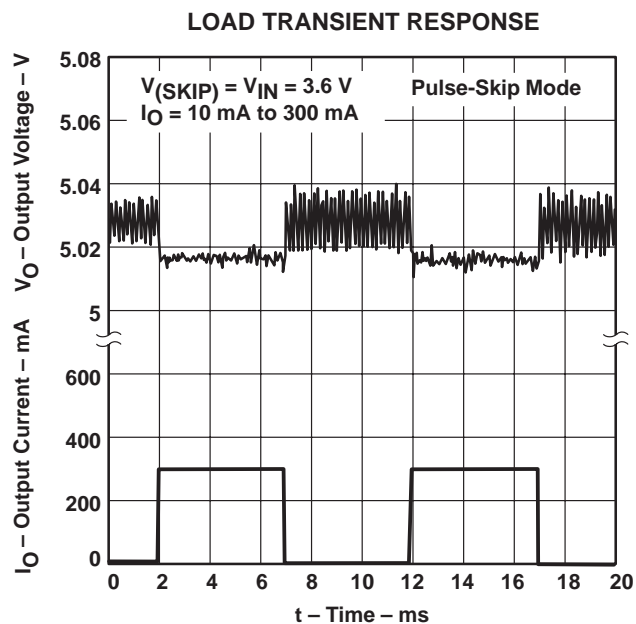

Figure 16

†  $T_{\text{C}} = 25^{\circ}\text{C}$ ,  $V_{\text{COM}} = V_{\text{SYNC}} = 0 \text{ V}$ ,  $C_{\text{IN}} = 15 \mu\text{F}$ ,  $C_{1\text{F}} = C_{2\text{F}} = 2.2 \mu\text{F}$ ,  $C_{\text{O}} = 33 \mu\text{F}$ , unless otherwise noted

**TPS60110**  
**REGULATED 5-V 300-mA LOW-NOISE**  
**CHARGE PUMP DC/DC CONVERTER**

SLVS215A – JUNE 1999 – REVISED SEPTEMBER 1999

**TYPICAL CHARACTERISTICS†**

**LINE TRANSIENT RESPONSE**

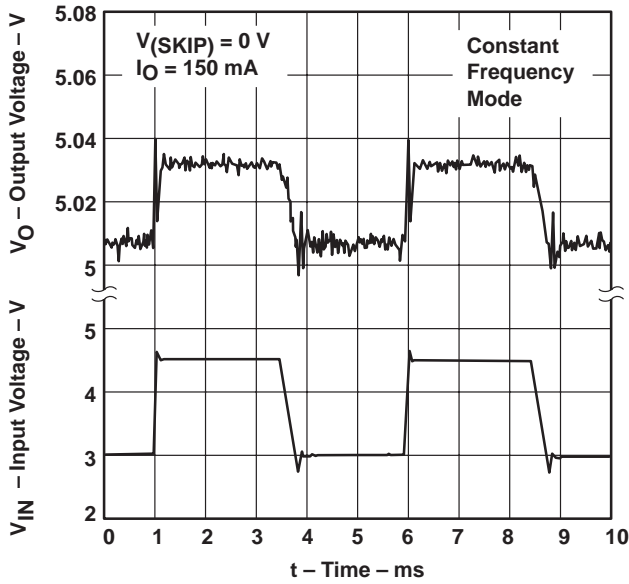

**Figure 17**

**LINE TRANSIENT RESPONSE**

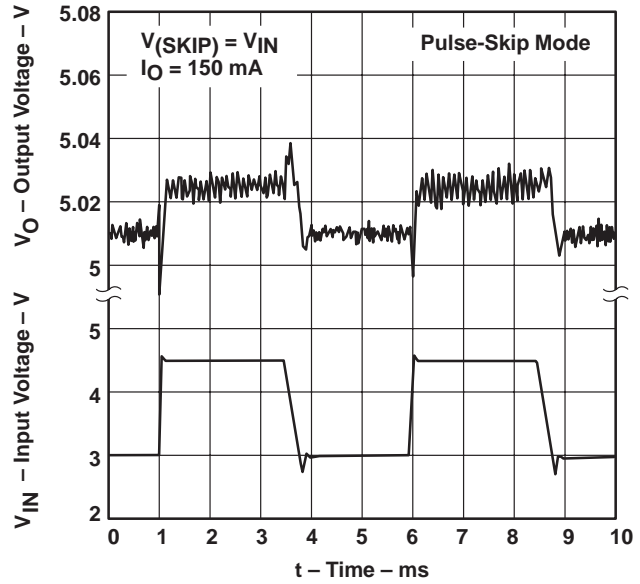

**Figure 18**

**FREQUENCY SPECTRUM**  
**CONSTANT FREQUENCY MODE‡**

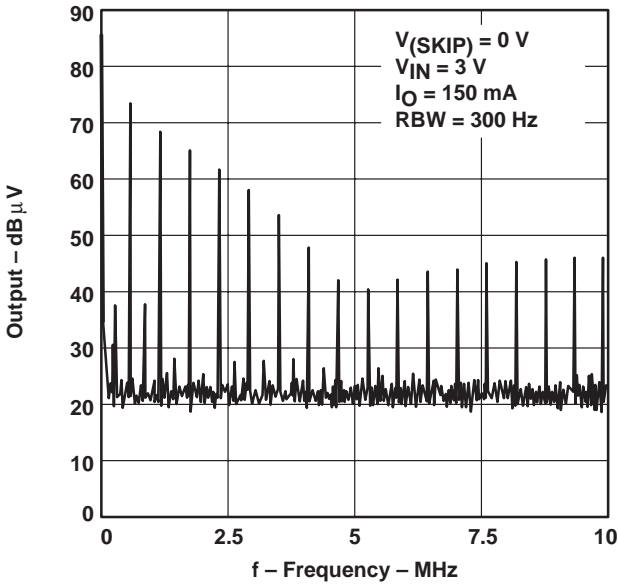

**Figure 19**

**FREQUENCY SPECTRUM**  
**PULSE-SKIP MODE‡**

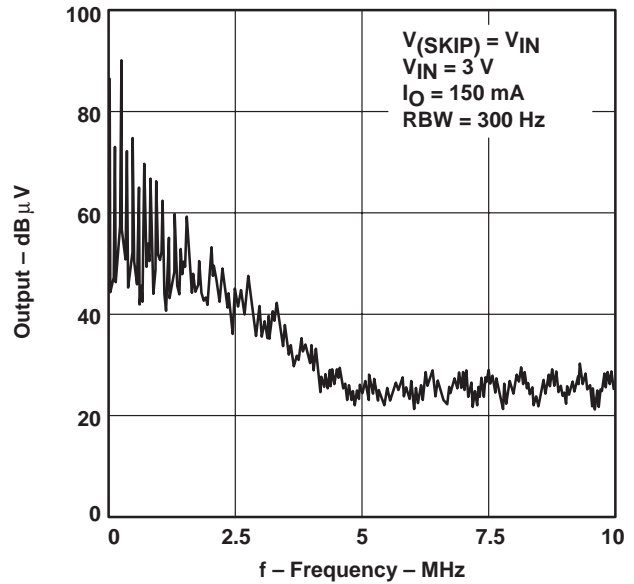

**Figure 20**

†  $T_C = 25^\circ\text{C}$ ,  $V_{COM} = V_{SYNC} = 0\text{ V}$ ,  $C_{IN} = 15\ \mu\text{F}$ ,  $C_{1F} = C_{2F} = 2.2\ \mu\text{F}$ ,  $C_O = 33\ \mu\text{F}$ , unless otherwise noted

‡ Test circuit: TPS60110EVM-132



TYPICAL CHARACTERISTICS†

FREQUENCY SPECTRUM  
 CONSTANT FREQUENCY MODE‡

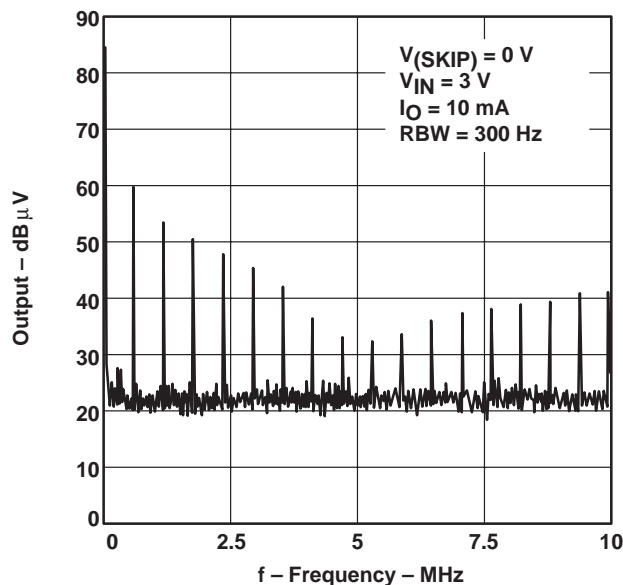

Figure 21

FREQUENCY SPECTRUM  
 PULSE-SKIP MODE‡

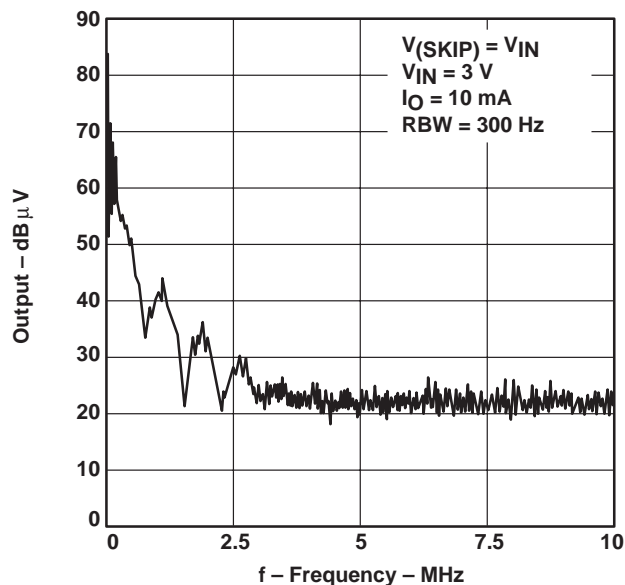

Figure 22

EFFICIENCY  
 vs  
 INPUT VOLTAGE

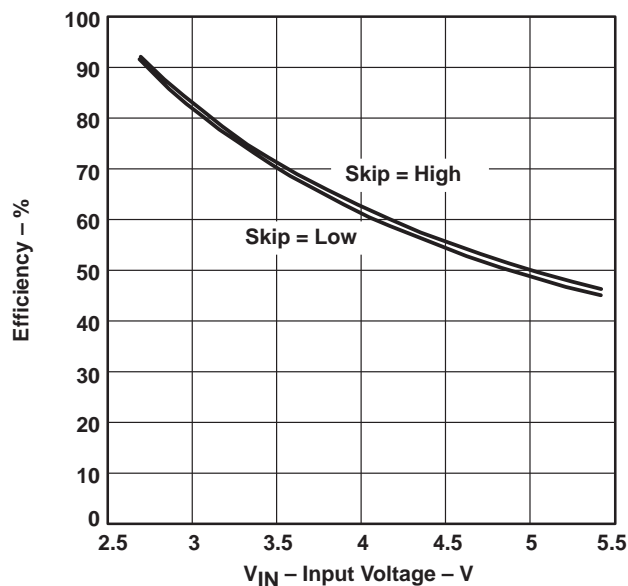

Figure 23

START-UP TIMING

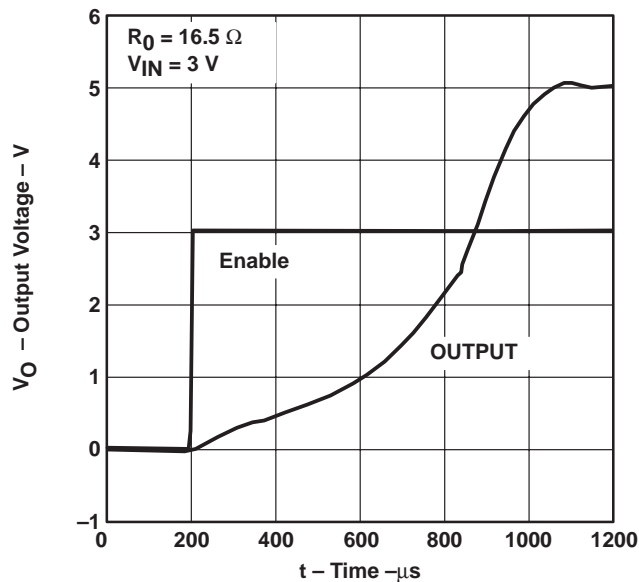

Figure 24

†  $T_C = 25^\circ\text{C}$ ,  $V_{COM} = V_{SYNC} = 0\text{ V}$ ,  $C_{IN} = 15\ \mu\text{F}$ ,  $C_{1F} = C_{2F} = 2.2\ \mu\text{F}$ ,  $C_O = 33\ \mu\text{F}$ , unless otherwise noted  
 ‡ Test circuit: TPS60110EVM-132

# TPS60110 REGULATED 5-V 300-mA LOW-NOISE CHARGE PUMP DC/DC CONVERTER

SLVS215A – JUNE 1999 – REVISED SEPTEMBER 1999

## detailed description

### operating principle

The TPS60110 charge pump provides a regulated 5-V output from a 2.7-V to 5.4-V input. It delivers a maximum load current of 300 mA. Designed specifically for space critical battery powered applications, the complete charge pump circuit requires only four external capacitors. The circuit can be optimized for highest efficiency at light loads or lowest output noise. The TPS60110 consists of an oscillator, a 1.22-V bandgap reference, an internal resistive feedback circuit, an error amplifier, high current MOSFET switches, a shutdown/start-up circuit, and a control circuit (Figure 25)

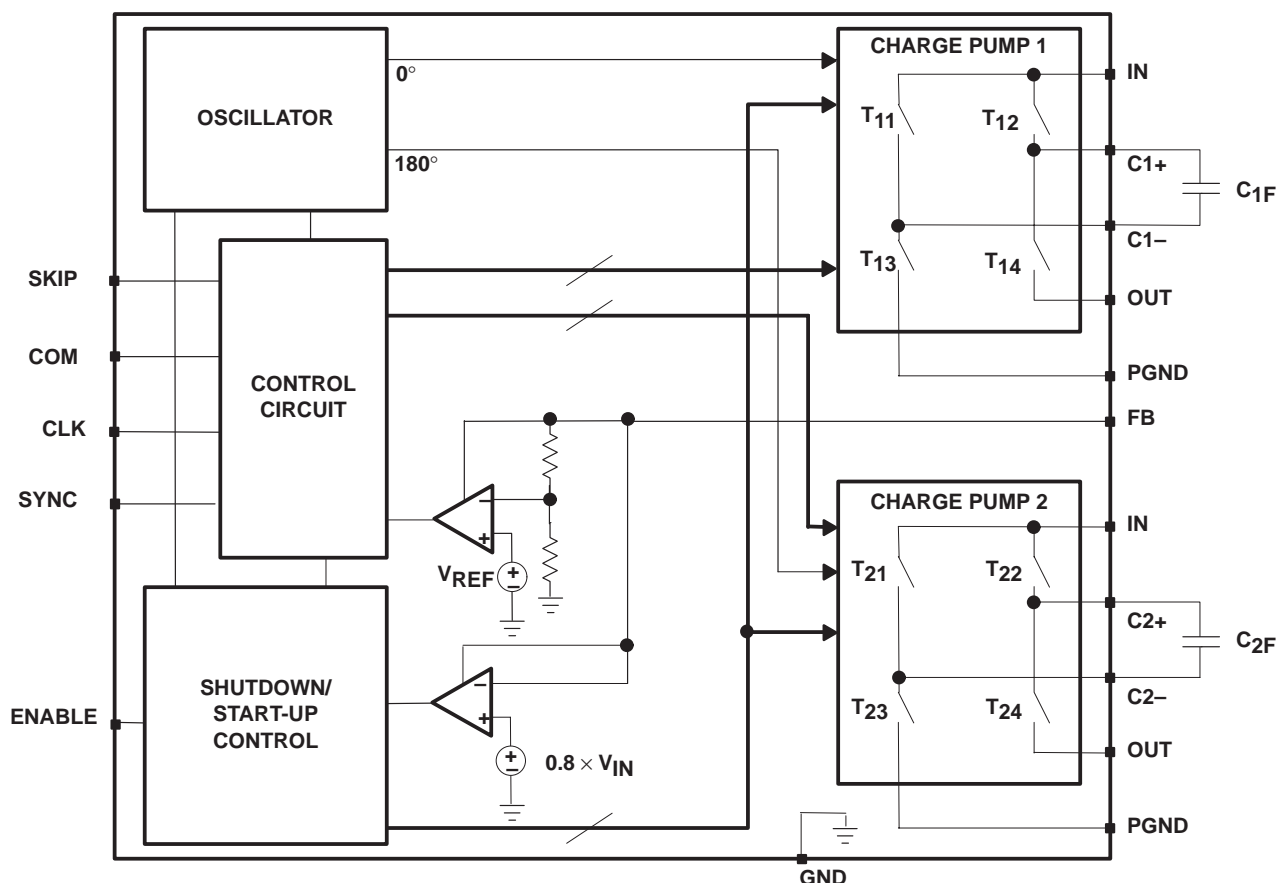

Figure 25. Functional Block Diagram TPS60110

The oscillator runs at a 50% duty cycle. The device consists of two single-ended charge pumps which operate with 180° phase shift. Each single ended charge pump transfers charge into its transfer capacitor ( $C_{XF}$ ) in one half of the period. During the other half of the period (transfer phase),  $C_{XF}$  is placed in series with the input to transfer its charge to  $C_O$ . While one single-ended charge pump is in the charge phase, the other one is in the transfer phase. This operation guarantees an almost constant output current which ensures a low output ripple.

If the clock were to run continuously, this process would eventually generate an output voltage equal to two times the input voltage (hence the name doubler). In order to provide a regulated fixed output voltage of 5 V, the TPS60110 uses either pulse-skip mode or constant-frequency mode. Pulse-skip mode and constant-frequency mode are externally selected via the SKIP input pin.

**detailed description (continued)**

**start-up procedure**

During start-up, i.e. when ENABLE is set from logic low to logic high, the switches T12 and T14 (charge pump 1), and the switches T22 and T24 (charge pump 2) are conducting to charge up the output capacitor until the output voltage  $V_O$  reaches  $0.8 \times V_{IN}$ . When the start-up comparator detects this limit, the IC begins to operate in the mode selected with SKIP and COM. This start-up charging of the output capacitor guarantees a short start-up time and eliminates the need for a Schottky diode between IN and OUT.

**pulse-skip mode**

In pulse-skip mode (SKIP = high), the error amplifier disables switching of the power stages when it detects an output higher than 5 V. The oscillator halts. The IC then skips switching cycles until the output voltage drops below 5 V. Then the error amplifier reactivates the oscillator and switching of the power stages starts again. The pulse-skip regulation mode minimizes operating current because it does not switch continuously and deactivates all functions except bandgap reference and error amplifier when the output is higher than 5 V. When switching is disabled from the error amplifier, the load is also isolated from the input. SKIP is a logic input and should not remain floating. The typical operating circuit of the TPS60110 in pulse skip mode is shown in Figure 1.

**constant-frequency mode**

When SKIP is low, the charge pump runs continuously at the frequency  $f_{OSC}$ . The control circuit, fed from the error amplifier, controls the charge on  $C_{1F}$  and  $C_{2F}$  by driving the gates of the FETs  $T_{12}/T_{13}$  and  $T_{22}/T_{23}$ , respectively. When the output voltage falls, the gate drive increases, resulting in a larger voltage across  $C_{1F}$  and  $C_{2F}$ . This regulation scheme minimizes output ripple. Since the device switches continuously, the output noise contains well-defined frequency components, and the circuit requires smaller external capacitors for a given output ripple. However, constant-frequency mode, due to higher operating current, is less efficient at light loads than pulse-skip mode.

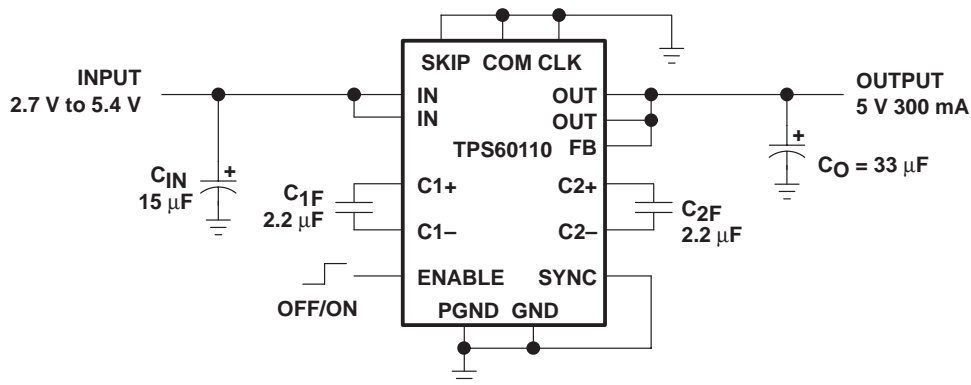

**Figure 26. Typical Operating Circuit TPS60110 in Constant Frequency Mode**

**Table 1. Tradeoffs Between Operating Modes**

FEATURE	PULSE-SKIP MODE (SKIP = High)	CONSTANT-FREQUENCY MODE (SKIP = Low)
Best light-load efficiency	X	
Smallest external component size for a given output ripple		X
Output ripple amplitude	Small amplitude	Very small amplitude
Output ripple frequency	Variable	Constant
Load regulation	Very good	Good

NOTE: Even in pulse-skip mode the output ripple amplitude is small if the push-pull operating mode is selected via COM.

# TPS60110 REGULATED 5-V 300-mA LOW-NOISE CHARGE PUMP DC/DC CONVERTER

SLVS215A – JUNE 1999 – REVISED SEPTEMBER 1999

## detailed description (continued)

### push-pull operating mode

In push-pull operating mode (COM = low), the two single-ended charge pumps operate with 180° phase shift. The oscillator signal has a 50% duty cycle. Each single-ended charge pump transfers charge into its transfer capacitor ( $C_{XF}$ ) in one-half of the period. During the other half of the period (transfer phase),  $C_{XF}$  is placed in series with the input to transfer its charge to  $C_O$ . While one single-ended charge pump is in the charge phase, the other one is in the transfer phase. This operation guarantees an almost constant output current which ensures a low output ripple. COM is a logic input and should not remain floating. The typical operating circuit of the TPS60110 in push-pull mode is shown in Figure 1 and Figure 26.

### single-ended operating mode

When COM is high, the device runs in single-ended operating mode. The two single-ended charge pumps operate in parallel without phase shift. They transfer charge into the transfer capacitor ( $C_F$ ) in one half of the period. During the other half of the period (transfer phase),  $C_F$  is placed in series with the input to transfer its charge to  $C_O$ . In single-ended operating mode only one transfer capacitor ( $C_F = C_{1F} + C_{2F}$ ) is required, resulting in less board space.

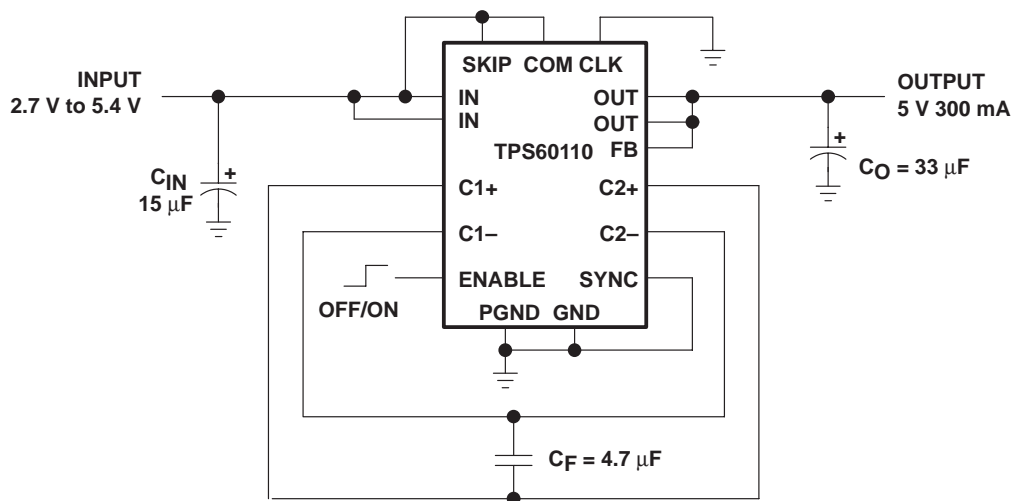

Figure 27. Typical Operating Circuit TPS60110 in Single-Ended Operating Mode

Table 2. Tradeoffs Between Operating Modes

FEATURE	PUSH-PULL MODE (COM = Low)	SINGLE-ENDED MODE (COM = High)
Output ripple amplitude	Small amplitude	Large amplitude
Smallest board space		X

**detailed description (continued)**

**shutdown**

Driving ENABLE low places the device in shutdown mode. This disables all switches, the oscillator, and control logic. The device typically draws 0.05- $\mu\text{A}$  (1- $\mu\text{A}$  max) of supply current in this mode. Leakage current drawn from the output is as low as 1  $\mu\text{A}$  max. The device exits shutdown once ENABLE is set high level. The typical no-load shutdown exit time is 20  $\mu\text{s}$ . When the device is in shutdown, the load is isolated from the input and the output is high impedance.

**external clock signal**

If the device operates at a user defined frequency, an external clock signal can be used. Therefore, SYNC needs to be connected to IN and the external oscillator signal can drive CLK. The maximum external frequency is limited to 800 kHz. The switching frequency of the converter is half of the external oscillator frequency. It is recommended to operate the charge pump in constant-frequency mode if an external clock signal is used so that the output noise contains only well-defined frequency components.

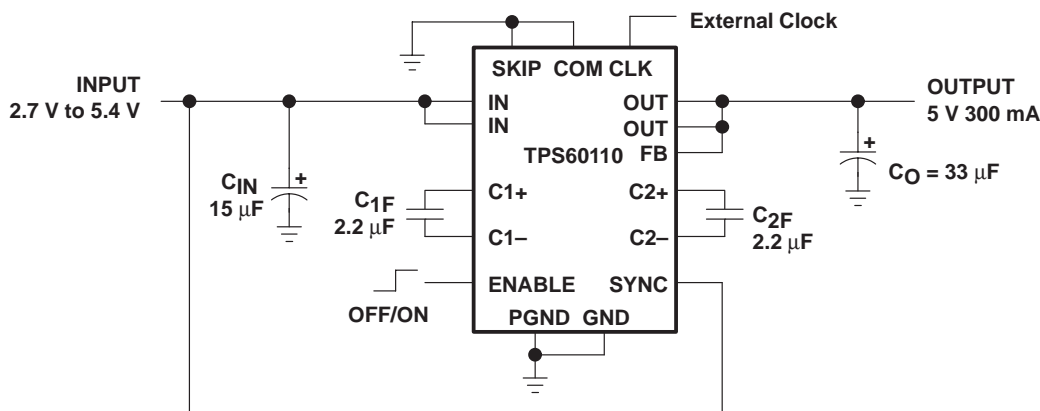

**Figure 28. Typical Operating Circuit TPS60110 With External Synchronization**

**TPS60110**  
**REGULATED 5-V 300-mA LOW-NOISE**  
**CHARGE PUMP DC/DC CONVERTER**

SLVS215A – JUNE 1999 – REVISED SEPTEMBER 1999

**APPLICATION INFORMATION**

**capacitor selection**

The TPS60110 requires only four external capacitors as shown in the basic application circuit. Their values are closely linked to the output current capacity, output noise requirements, and mode of operation. Generally, the transfer capacitors ( $C_{XF}$ ) will be the smallest.

The input capacitor improves system efficiency by reducing the input impedance and stabilizes the input current.  $C_{IN}$  is recommended to be about two to four times as large as  $C_{XF}$ .

The output capacitor ( $C_O$ ) can be selected from 8-times to 50-times larger than  $C_{XF}$ , depending on the mode of operation and ripple tolerance†. Tables 3 and 4 show capacitor values recommended for low quiescent-current operation (pulse-skip mode) and for low output voltage ripple operation (constant-frequency mode). A recommendation is given for smallest size.

**Table 3. Recommended Capacitor Values for Low Quiescent-Current Operation† (pulse-skip mode)**

$V_{IN}$ [V]	$I_O$ [mA]	$C_{IN}$ [ $\mu$ F]		$C_{XF}$ [ $\mu$ F]	$C_O$ [ $\mu$ F]		OUTPUT VOLTAGE RIPPLE $V_{PP}$ [mV]
		TANTALUM	CERAMIC		TANTALUM	CERAMIC	
3.6	225	15		2.2	33		145
3.6	225		4.7 + 10, (X5R)	2.2		22 + 10, (X5R)	55
3.6	300	15		2.2	33		135
3.6	300		4.7 + 10, (X5R)	2.2		22 + 10, (X5R)	75

† All measurements are done with additional 1- $\mu$ F X7R ceramic capacitors at input and output.

**Table 4. Recommended Capacitor Values for Low Output Voltage Ripple Operation† (constant-frequency mode)**

$V_{IN}$ [V]	$I_O$ [mA]	$C_{IN}$ [ $\mu$ F]		$C_{XF}$ [ $\mu$ F]	$C_O$ [ $\mu$ F]		OUTPUT VOLTAGE RIPPLE $V_{PP}$ [mV]
		TANTALUM	CERAMIC		TANTALUM	CERAMIC	
3.6	225	15		2.2	33		17
3.6	225		4.7 + 10, (X5R)	2.2		22 + 10, (X5R)	6
3.6	300	15		2.2	33		22
3.6	300		4.7 + 10, (X5R)	2.2		22 + 10, (X5R)	8

† All measurements are done with additional 1- $\mu$ F X7R ceramic capacitors at input and output.

† In constant-frequency mode always select  $C_O \geq 33 \mu$ F



### APPLICATION INFORMATION

For the TPS60110, the smallest board space size can be achieved using Sprague's 595D-series tantalum capacitors for input and output. However, with the trend towards high capacitance ceramic capacitors in smaller size packages, these type of capacitors might soon become competitive in size.

**Table 5. Recommended Capacitors**

MANUFACTURER	PART NUMBER	CAPACITANCE	TYPE
Taiyo Yuden	LMK212BJ105KG-T	1 $\mu$ F	Ceramic
	LMK212BJ225MG-T	2.2 $\mu$ F	Ceramic
	LMK316BJ475KL-T	4.7 $\mu$ F	Ceramic
	JMK316BJ106ML-T	10 $\mu$ F	Ceramic
	LMK432BJ226MM-T	22 $\mu$ F	Ceramic
AVX	0805ZC105KAT2A	1 $\mu$ F	Ceramic
	1206ZC225KAT2A	2.2 $\mu$ F	Ceramic
	TPSC156K020R0450	15 $\mu$ F	Tantalum
	TPSC336K010R0375	33 $\mu$ F	Tantalum
Sprague	595D156X06R3A2T	15 $\mu$ F	Tantalum
	595D156X0016B2T	15 $\mu$ F	Tantalum
	595D336X06R3A2T	33 $\mu$ F	Tantalum
	595D336X0016B2T	33 $\mu$ F	Tantalum
	595D336X0016C2T	33 $\mu$ F	Tantalum
Kemet	T494C156K010AS	15 $\mu$ F	Tantalum
	T494C336K010AS	33 $\mu$ F	Tantalum

Table 6 lists the manufacturers of recommended capacitors. In most applications surface-mount tantalum capacitors will be the right choice. However, ceramic capacitors will provide the lowest output voltage ripple due to their typically lower ESR.

**Table 6. Recommended Capacitor Manufacturers**

MANUFACTURER	CAPACITOR TYPE	INTERNET
Taiyo Yuden	X7R/X5R ceramic	<a href="http://www.t-yuden.com">www.t-yuden.com</a>
AVX	X7R/X5R ceramic TPS-series tantalum	<a href="http://www.avxcorp.com">www.avxcorp.com</a>
Sprague	595D-series tantalum 593D-series tantalum	<a href="http://www.vishay.com">www.vishay.com</a>
Kemet	T494-series tantalum	<a href="http://www.kemet.com">www.kemet.com</a>

#### power dissipation

The power dissipated in the TPS60110 depends on output current and is approximated by:

$$P_{DISS} = I_O \times (2 V_{IN} - V_O) \text{ for } I_Q \ll I_O$$

$P_{DISS}$  must be less than that allowed by the package rating. See the ratings for 20-PowerPAD™ package power-dissipation limits and deratings.

# TPS60110 REGULATED 5-V 300-mA LOW-NOISE CHARGE PUMP DC/DC CONVERTER

SLVS215A – JUNE 1999 – REVISED SEPTEMBER 1999

## APPLICATION INFORMATION

### layout

All capacitors should be soldered in close proximity to the IC. A PCB layout proposal for a two-layer board is given in Figure 29. Care has been taken to connect both single-ended charge pumps symmetrically to the load to achieve optimized output voltage ripple performance. The proposed layout also provides improved thermal performance as the exposed leadframe is soldered to the PCB. The bottom layer of the PCB is a ground plane only. All ground areas on the PCB should be connected. Connect ground areas on top layer to the bottom layer via through hole connections.

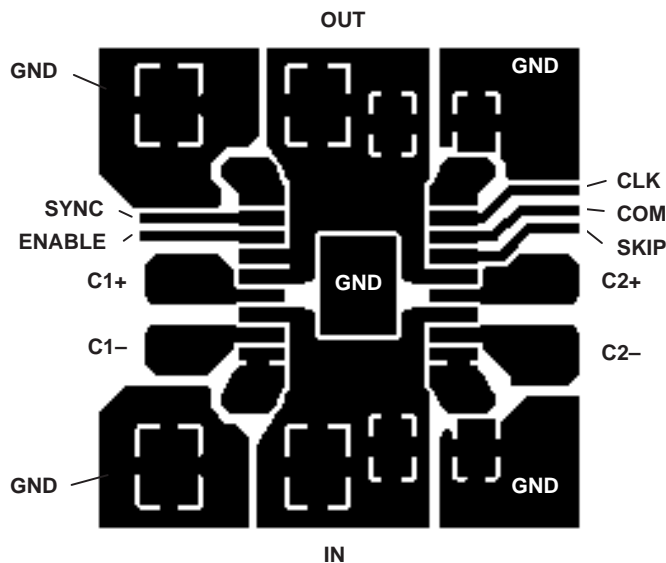

Figure 29. Recommended PCB Layout for TPS60110 (top view)

An evaluation module for the TPS60110 is available and can be ordered under literature code SLVP132 or under product code TPS60110EVM-132.



## APPLICATION INFORMATION

### applications proposals

#### paralleling of two TPS60110 to deliver 600 mA

The TPS60110 can be paralleled to yield higher load currents. The circuit of Figure 30 can deliver 600 mA at an output voltage of 5 V. It uses two TPS60110 devices in parallel. The devices can share the output capacitors, but each one requires its own transfer capacitors and input capacitor. For best performance, the paralleled devices should operate in the same mode (pulse-skip or constant frequency).

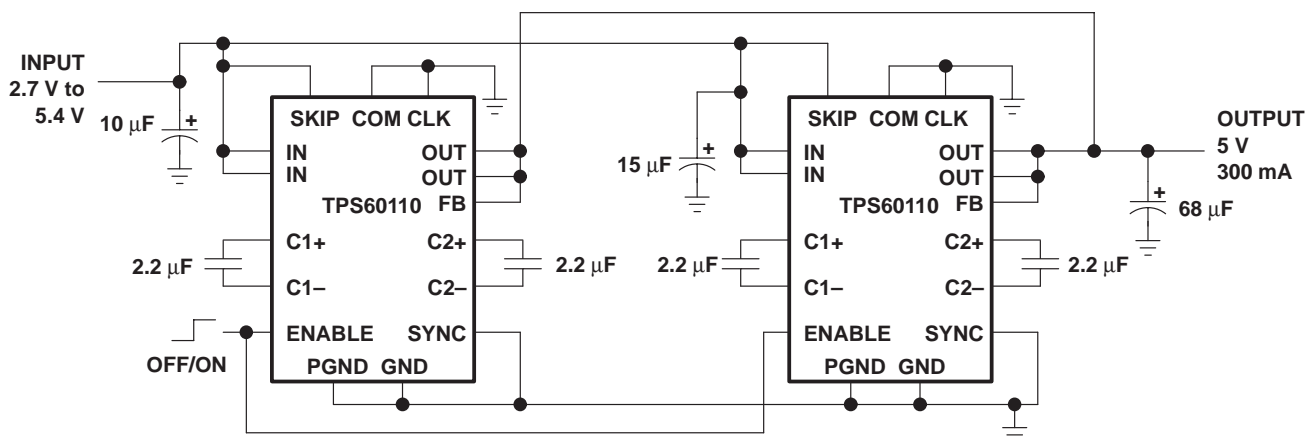

**Figure 30. Paralleling of Two TPS60110**

#### TPS60110 with LC output filter for ultra low ripple

For applications where extremely low output ripple is required, a small LC filter is recommended. This is shown in Figure 31. The addition of a small inductor and filter capacitor will reduce the output ripple well below what could be achieved with capacitors alone. The corner frequency of 500 kHz was chosen above the 300 kHz switching frequency to avoid loop stability issues in case the feedback is taken from the output of the LC filter. Leaving the feedback (FB) connection point before the LC filter, the filter capacitance value can be increased to achieve even higher ripple attenuation without affecting stability margin.

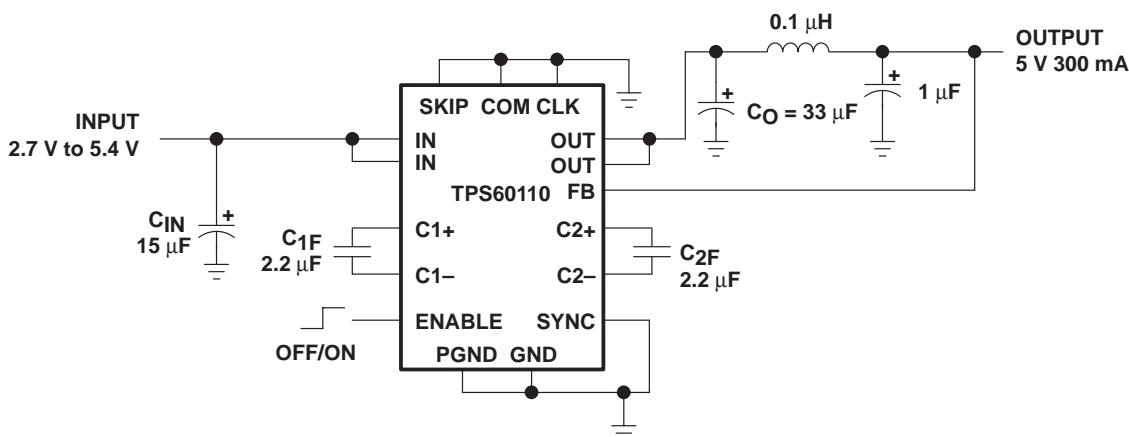

**Figure 31. TPS60110 With LC Filter for Ultra Low Output Ripple Applications**

# TPS60110 REGULATED 5-V 300-mA LOW-NOISE CHARGE PUMP DC/DC CONVERTER

SLVS215A – JUNE 1999 – REVISED SEPTEMBER 1999

---

## APPLICATION INFORMATION

### related information

### application reports

For more application information see:

- *PowerPAD™ Application Report* (Literature Number: SLMA002)
- *TPS6010x/TPS6011x Charge Pump Application Report* (Literature Number: SLVA070)

### device family products

Other devices in this family are:

PART NUMBER	LITERATURE NUMBER	DESCRIPTION
TPS60100	SLVS213	Regulated 3.3-V, 200-mA Low-Noise Charge Pump DC/DC Converter
TPS60101	SLVS214	Regulated 3.3-V, 100-mA Low-Noise Charge Pump DC/DC Converter
TPS60111	SLVS216	Regulated 5-V, 150-mA Low-Noise Charge Pump DC/DC Converter

**MECHANICAL DATA**

**PWP (R-PDSO-G\*\*)**

**PowerPAD™ PLASTIC SMALL-OUTLINE PACKAGE**

20-PIN SHOWN

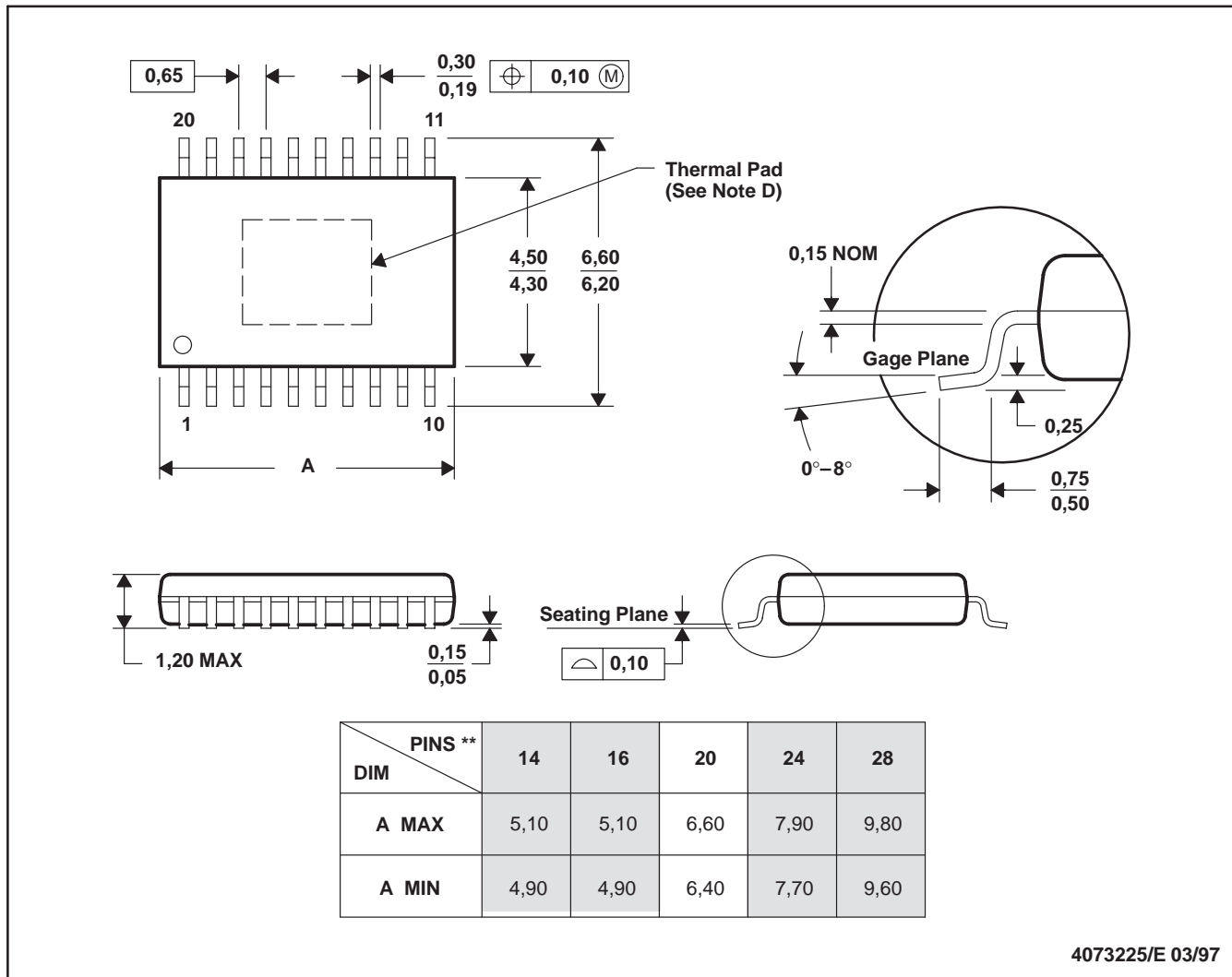

- NOTES: A. All linear dimensions are in millimeters.  
 B. This drawing is subject to change without notice.  
 C. Body dimensions do not include mold flash or protrusions.  
 D. The package thermal performance may be enhanced by bonding the thermal pad to an external thermal plane. This pad is electrically and thermally connected to the backside of the die and possibly selected leads.  
 E. Falls within JEDEC MO-153

PowerPAD is a trademark of Texas Instruments Incorporated.

## IMPORTANT NOTICE

Texas Instruments and its subsidiaries (TI) reserve the right to make changes to their products or to discontinue any product or service without notice, and advise customers to obtain the latest version of relevant information to verify, before placing orders, that information being relied on is current and complete. All products are sold subject to the terms and conditions of sale supplied at the time of order acknowledgement, including those pertaining to warranty, patent infringement, and limitation of liability.

TI warrants performance of its semiconductor products to the specifications applicable at the time of sale in accordance with TI's standard warranty. Testing and other quality control techniques are utilized to the extent TI deems necessary to support this warranty. Specific testing of all parameters of each device is not necessarily performed, except those mandated by government requirements.

CERTAIN APPLICATIONS USING SEMICONDUCTOR PRODUCTS MAY INVOLVE POTENTIAL RISKS OF DEATH, PERSONAL INJURY, OR SEVERE PROPERTY OR ENVIRONMENTAL DAMAGE ("CRITICAL APPLICATIONS"). TI SEMICONDUCTOR PRODUCTS ARE NOT DESIGNED, AUTHORIZED, OR WARRANTED TO BE SUITABLE FOR USE IN LIFE-SUPPORT DEVICES OR SYSTEMS OR OTHER CRITICAL APPLICATIONS. INCLUSION OF TI PRODUCTS IN SUCH APPLICATIONS IS UNDERSTOOD TO BE FULLY AT THE CUSTOMER'S RISK.

In order to minimize risks associated with the customer's applications, adequate design and operating safeguards must be provided by the customer to minimize inherent or procedural hazards.

TI assumes no liability for applications assistance or customer product design. TI does not warrant or represent that any license, either express or implied, is granted under any patent right, copyright, mask work right, or other intellectual property right of TI covering or relating to any combination, machine, or process in which such semiconductor products or services might be or are used. TI's publication of information regarding any third party's products or services does not constitute TI's approval, warranty or endorsement thereof.