

9097247 TOSHIBA. ELECTRONIC

02E 17472 D

TA7654P

T-52-13-07

5 LED'S DRIVER

- . Logarithmic Level Indicator (-10, -5, 0, +3, +6dB)
- . LED Drive Current Up to 30mA
- . Driving Capability, Green and Red LED
- . Two Inputs and Output Amplifier with Selectivity Gain
- . Superiority Operation for Larger Input Voltage.
- . Linear Level Detector and Logarithmic Comparator.
- . Open Collector Output, Low Power Dissipation and Wide Supply Voltage Range : $V_{CC}=4 \sim 13V$
- . Low Quiescent Current: $I_{CCQ}=1.7mA(Typ.)$ at $V_{CC}=9V$
- . Stable Reference Voltage for Supply Voltage:
 $V_{ref}=1.25V \pm 0.1V$ at $V_{CC}=4 \sim 13V$

Unit in mm

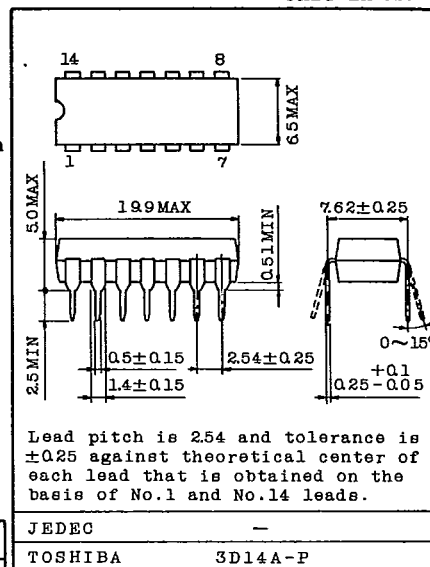
MAXIMUM RATINGS ($T_a=25^\circ C$)

CHARACTERISTIC	SYMBOL	RATING	UNIT
Supply Voltage	V_{CC}	14	V
Output Current	I_O	30	mA
Power Dissipation (Note)	P_D	625	mW
Operating Temperature	T_{opr}	$-30 \sim 75$	$^\circ C$
Storage Temperature	T_{stg}	$-55 \sim 150$	$^\circ C$

Note: Derated above $T_a=25^\circ C$ in the proportion of $5mW/^\circ C$.ELECTRICAL CHARACTERISTICS ($V_{CC}=9V, f=1kHz, T_a=25^\circ C$)

CHARACTERISTIC	SYMBOL	TEST CIR-CUIT	TEST CONDITION	MIN.	TYP.	MAX.	UNIT
Quiescent Current	I_{CCQ}	-	INPUT=0	-	1.7	2.2	mA
Output Current	I_O	-	$V_{CE}=1V$	15	25	30	mA
Output Transistor Saturation Voltage	$V_{CE(sat)}$	-	$I_O=20mA$	-	0.5	-	V
Output Leak Current	$I_{O(OFF)}$	-	INPUT=0	-	-	50	μA
Output Offset Voltage	V_{OFF}	-	$G_v=15dB$	-	20	100	mV
Reference Voltage	V_{ref}	-	-	1.15	1.25	1.35	V
Comparator Level	LD5	-	$C_{IN(+)}=1.25V, C_{IN(-)}=0$	5	6	7	dB
	LD4	-	$C_{IN(+)}=0.88V, C_{IN(-)}=0$	2.5	3	3.5	dB
	LD3	-	$C_{IN(+)}=0.625V, C_{IN(-)}=0$	-0.5	0	0.5	dB
	LD2	-	$C_{IN(+)}=0.35V, C_{IN(-)}=0$	-5.5	-5	-4.5	dB
	LD1	-	$C_{IN(+)}=0.2V, C_{IN(-)}=0$	-11	-10	-9	dB

AUDIO LINEAR IC

9097247 TOSHIBA, ELECTRONIC

02E 17473 D

TA7654P

T-52-13-07

TEST CIRCUIT/BLOCK DIAGRAM

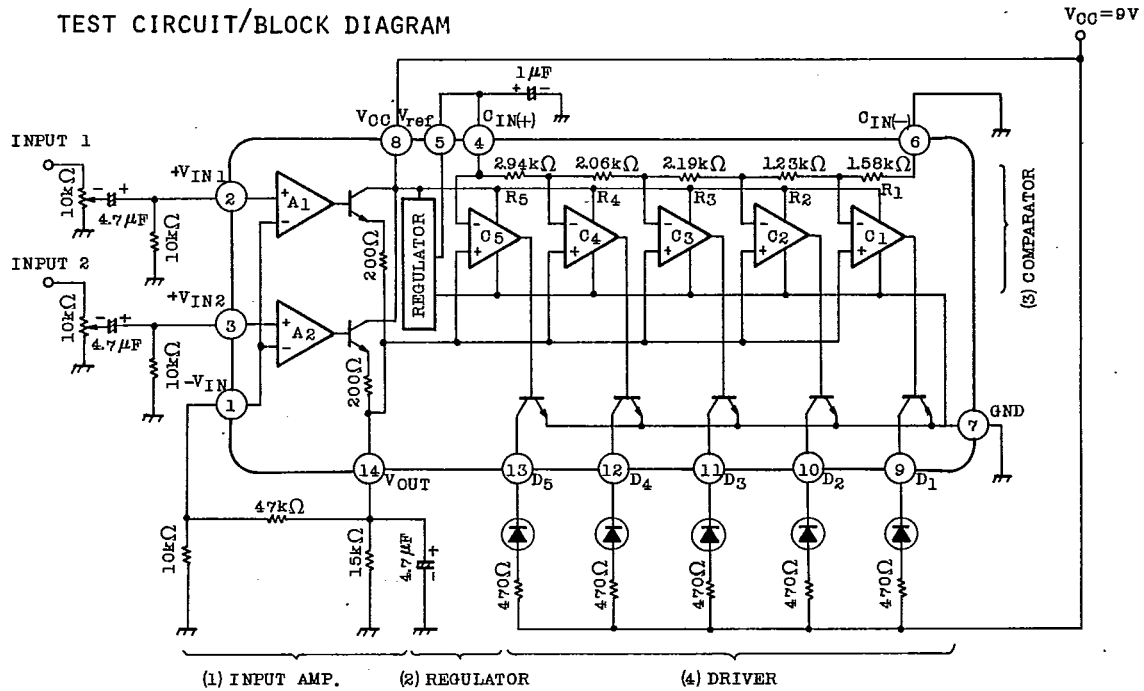

ABSTRACT OF THIS IC

This IC consists of (1) Input Amplifier, (2) Regulator, (3) Comparator and (4) Driver.

(1) Input Amplifier

It consists of the differential amplifier and the emitter follower. The function is the amplifier, the peak detector and the peak hold. There are two input amplifiers with parallel and the amplifier with larger input voltage operates.

(2) Regulator

It is stable to the ambient temperature drift and supply voltage variation. The reference voltage is 1.25V. It is used for the reference of the comparator.

(3) Comparator

It consists of the five comparators and ladder resistor. It drives the transistor that drives the LED in correspond to the output voltage of the amplifier.

(4) Driver

Each driver is the open collector and sinks current of 30mA.

TOSHIBA