

SFP - Small Form-factor Pluggable **V23818-M305-B57**
Multimode 850 nm 2.125 and 1.0625 Gbit/s Fibre Channel
1.25 Gigabit Ethernet Transceiver with LC™ Connector

Features

- Small Form-factor Pluggable (SFP) transceiver
- Fully SFP MSA compliant¹⁾
- Advanced release mechanism
 - Easy access, even in belly to belly applications
 - Grip for easy access – no tool is needed
 - Color coded black (multimode)
- Excellent EMI performance
- RJ-45 style LC™ connector system
- Single power supply (3.3 V)
- Extremely low power consumption of 415 mW typical
- Small size for high channel density
- UL-94 V-0 certified
- ESD Class 1C per JESD22-A114-B (MIL-STD 883D Method 3015.7)
- Compliant with FCC (Class B) and EN 55022
- For distances of up to 700 m (50 µm fiber)
- Class 1 FDA and IEC laser safety compliant
- AC/AC Coupling according to SFP MSA
- Recommendation: Infineon Cage one-piece design V23838-S5-N1 for press fit and/or solderable
- Operating case temperature: –10°C to 85°C
- SFP evaluation board V23818-S5-V2 available upon request

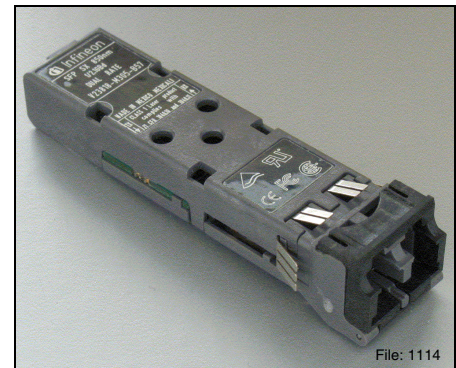

¹⁾ Current MSA documentation can be found at www.infineon.com/fiberoptics

LC™ is a trademark of Lucent

Pin Configuration

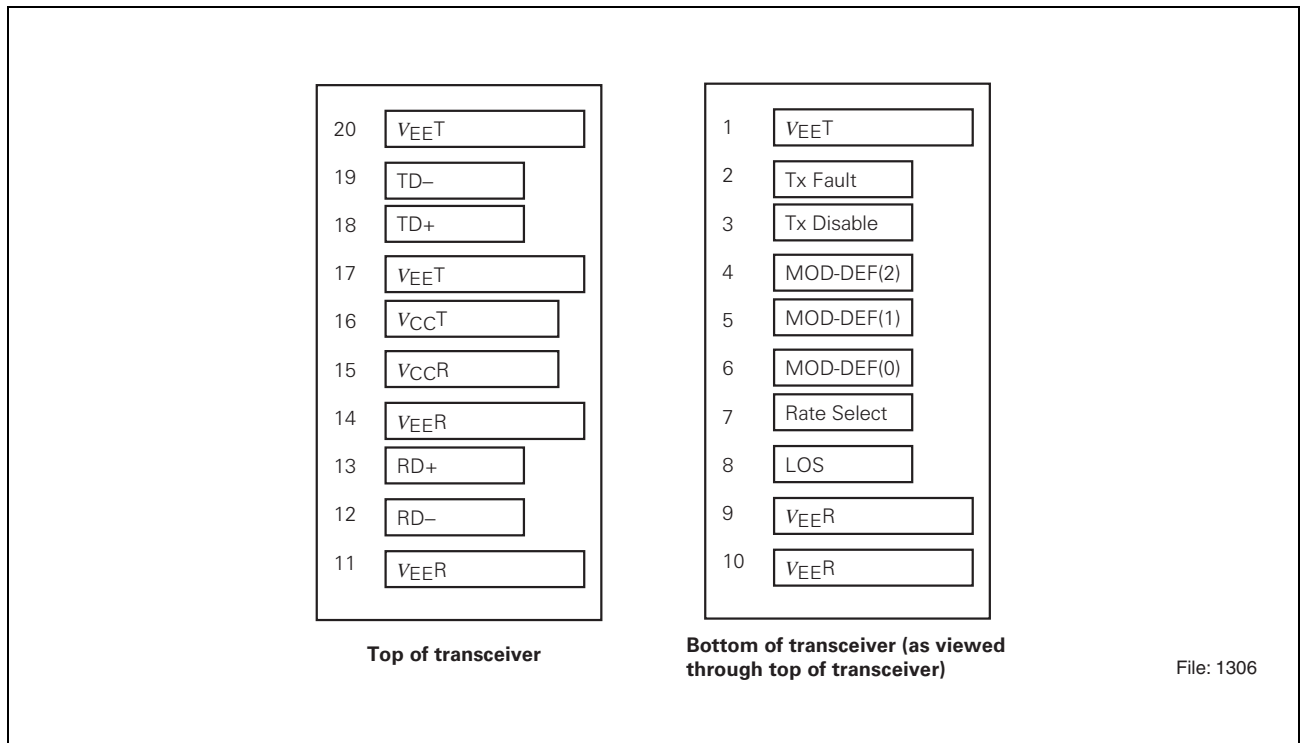

Figure 1 SFP Transceiver Electrical Pad Layout

Pin Configuration
Pin Description

Pin No.	Name	Logic Level	Function
1	$V_{EE}T$	N/A	Transmitter Ground ¹⁾
2	Tx Fault	LVTTTL	Transmitter Fault Indication ^{2) 8)}
3	Tx Disable	LVTTTL	Transmitter Disable ³⁾
4	MOD-DEF(2)	LVTTTL	Module Definition 2 ^{4) 8)}
5	MOD-DEF(1)	LVTTTL	Module Definition 1 ^{5) 8)}
6	MOD-DEF(0)	N/A	Module Definition 0 ^{6) 8)}
7	Rate Select	N/A	Not connected
8	LOS	LVTTTL	Loss Of Signal ^{7) 8)}
9	$V_{EE}R$	N/A	Receiver Ground ¹⁾
10	$V_{EE}R$	N/A	Receiver Ground ¹⁾
11	$V_{EE}R$	N/A	Receiver Ground ¹⁾
12	RD-	LVPECL	Inv. Received Data Out ⁹⁾
13	RD+	LVPECL	Received Data Out ⁹⁾
14	$V_{EE}R$	N/A	Receiver Ground ¹⁾
15	$V_{CC}R$	N/A	Receiver Power
16	$V_{CC}T$	N/A	Transmitter Power
17	$V_{EE}T$	N/A	Transmitter Ground ¹⁾
18	TD+	LVPECL	Transmit Data In ¹⁰⁾
19	TD-	LVPECL	Inv. Transmit Data In ¹⁰⁾
20	$V_{EE}T$	N/A	Transmitter Ground ¹⁾

¹⁾ Common transmitter and receiver ground within the module.

²⁾ A high signal indicates a laser fault of some kind and that laser is switched off.

³⁾ A low signal switches the transmitter on. A high signal or when not connected switches the transmitter off.

⁴⁾ MOD-DEF(2) is the data line of two wire serial interface for serial ID.

⁵⁾ MOD-DEF(1) is the clock line of two wire serial interface for serial ID.

⁶⁾ MOD-DEF(0) is grounded by the module to indicate that the module is present.

⁷⁾ A low signal indicates normal operation, light is present at receiver input. A high signal indicates the received optical power is below the worst case receiver sensitivity.

⁸⁾ Should be pulled up on host board to V_{CC} by 4.7 - 10 k Ω .

⁹⁾ AC coupled inside the transceiver. Must be terminated with 100 Ω differential at the user SERDES.

¹⁰⁾ AC coupled and 100 Ω differential termination inside the transceiver.

Description
Description

The Infineon Fibre Channel / Gigabit Ethernet multimode transceiver – part of Infineon Small Form Factor transceiver family – is based on the Physical Medium Depend (PMD) sublayer and baseband medium, type 1000 Base-SX (short wavelength) as specified in IEEE Std 802.3, Fibre Channel

FC-PI (Rev. 13) 200-M5-SN-I, 200-M6-SN-I,

FC-PI (Rev. 13) 100-M5-SN-I, 100-M6-SN-I.

The appropriate fiber optic cable is 62.5 μm or 50 μm multimode fiber with LC™ connector.

Link Length as Defined by IEEE and Fibre Channel Standards

Fiber Type	Reach		Unit
	min. ¹⁾	max. ²⁾	
at 1.0625 Gbit/s			
50 μm , 2000 MHz*km	0.5	860	meters
50 μm , 500 MHz*km	0.5	500	
50 μm , 400 MHz*km	0.5	450	
62.5 μm , 200 MHz*km	0.5	300	
62.5 μm , 160 MHz*km	0.5	250	
at 1.25 Gbit/s			
50 μm , 500 MHz*km	2	550	meters
50 μm , 400 MHz*km	2	500	
62.5 μm , 200 MHz*km	2	275	
62.5 μm , 160 MHz*km	2	220	
at 2.125 Gbit/s			
50 μm , 2000 MHz*km	0.5	500	meters
50 μm , 500 MHz*km	0.5	300	
50 μm , 400 MHz*km	0.5	260	
62.5 μm , 200 MHz*km	0.5	150	
62.5 μm , 160 MHz*km	0.5	120	

¹⁾ Minimum reach as defined by IEEE and Fibre Channel Standards. A 0 m link length (loop-back connector) is supported.

²⁾ Maximum reach as defined by IEEE and Fibre Channel Standards. Longer reach possible depending upon link implementation.

Description

The Infineon SFP multimode transceiver is a single unit comprised of a transmitter, a receiver, and an LC™ receptacle.

This transceiver supports the LC™ connectorization concept. It is compatible with RJ-45 style backpanels for high end datacom and telecom applications while providing the advantages of fiber optic technology.

The module is designed for low cost SAN, LAN, WAN, Fibre Channel applications. It can be used as the network end device interface in mainframes, workstations, servers, and storage devices, and in a broad range of network devices such as bridges, routers, hubs, and local and wide area switches.

This transceiver operates at 1.0625/1.25/2.125 Gbit/s from a single power supply (+3.3 V). The full differential data inputs and outputs are LVPECL compatible.

Functional Description of SFP Transceiver

This transceiver is designed to transmit serial data via multimode cable.

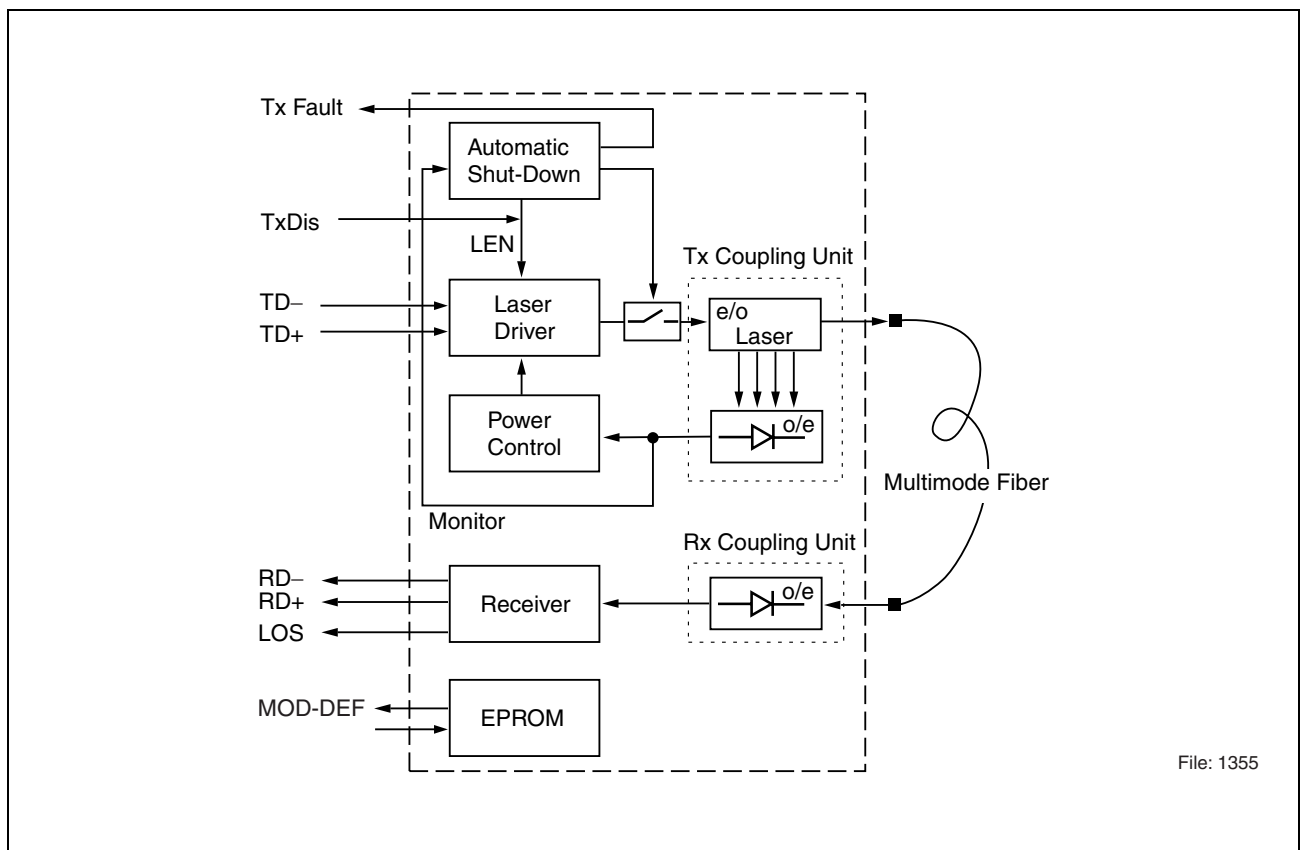

Figure 2 Functional Diagram

Description

The receiver component converts the optical serial data into LVPECL compatible electrical data (RD+ and RD–). The Loss Of Signal (LOS) shows whether an optical signal is present.

The transmitter converts LVPECL compatible electrical serial data (TD+ and TD–) into optical serial data. Data lines are differentially 100 Ω terminated.

The transmitter contains a laser driver circuit that drives the modulation and bias current of the laser diode. The currents are controlled by a power control circuit to guarantee constant output power of the laser over temperature and aging. The power control uses the output of the monitor PIN diode (mechanically built into the laser coupling unit) as a controlling signal, to prevent the laser power from exceeding the operating limits.

Single fault condition is ensured by means of an integrated automatic shutdown circuit that disables the laser when it detects laser fault to guarantee the laser Eye Safety.

The transceiver contains a supervisory circuit to control the power supply. This circuit makes an internal reset signal whenever the supply voltage drops below the reset threshold. It keeps the reset signal active for at least 140 milliseconds after the voltage has risen above the reset threshold. During this time the laser is inactive.

A low signal on TxDis enables transmitter. If TxDis is high or not connected the transmitter is disabled.

The information which kind of SFP module has been plugged into an SFP port can be read through the MOD-DEF interface. The information is stored in an I²C-Eprom inside the SFP Transceiver.

Description

Regulatory Compliance

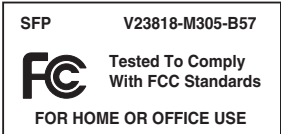
Feature	Standard	Comments
 <p style="text-align: center; font-size: small;">File: 1400</p>	Compliant with 89/336/EEC	EN 55022 EN 55024
ESD: Electrostatic Discharge to the Electrical Pins	EIA/JESD22-A114-B (MIL-STD 883D method 3015.7)	Class 1C
Immunity: Against Electrostatic Discharge (ESD) to the Duplex LC Receptacle	EN 61000-4-2 IEC 61000-4-2	Discharges ranging from ± 2 kV to ± 15 kV on the receptacle cause no damage to transceiver (under recommended conditions).
Immunity: Against Radio Frequency Electromagnetic Field	EN 61000-4-3 IEC 61000-4-3	With a field strength of 3 V/m, noise frequency ranges from 10 MHz to 2 GHz. No effect on transceiver performance between the specification limits.
Emission: Electromagnetic Interference (EMI)	FCC 47 CFR Part 15, Class B EN 55022 Class B CISPR 22	Noise frequency range: 30 MHz to 18 GHz
 <p style="text-align: center; font-size: small;">File: 1402</p>		This device complies with part 15 of the FCC Rules. Operation is subject to the following two conditions: 1 This device may not cause harmful interference. 2 This device must accept any interference received, including interference that may cause undesired operation.

Technical Data
Absolute Maximum Ratings

Parameter	Symbol	Limit Values		Unit
		min.	max.	
Package Power Dissipation			0.5	W
Data Input Levels			$V_{CC}+0.5$	V
Differential Data Input Voltage Swing	$V_{IDpk-pk}$		5	
Storage Ambient Temperature		-40	85	°C
V_{CC} max			5.5	V
ECL-Output Current Data			50	mA

Exceeding any one of these values may destroy the device immediately.

Recommended Operating Conditions

Parameter	Symbol	Limit Values			Unit
		min.	typ.	max.	
Case Temperature	T_C	-10		85	°C
Power Supply Voltage	$V_{CC}-V_{EE}$	3.1	3.3	3.5	V

Transmitter

Differential Data Input Voltage Swing	$V_{IDpk-pk}$	500		3200	mV
---------------------------------------	---------------	-----	--	------	----

Receiver

Input Center Wavelength	λ_C	770		860	nm
-------------------------	-------------	-----	--	-----	----

The electro-optical characteristics described in the following tables are valid only for use under the recommended operating conditions.

Transmitter Electro-Optical Characteristics

Transmitter	Symbol	Limit Values			Unit
		min.	typ.	max.	
Launched Power (Average) ¹⁾	P_O	-9.5	-6	-4	dBm
Optical Modulation Amplitude ²⁾ 2.125 Gbit/s 1.25/1.0625 Gbit/s	OMA	196 156	450 450		μ W
Center Wavelength	λ_C	830	850	860	nm
Spectral Width (RMS)	σ_I			0.85	
Relative Intensity Noise	RIN			-117	dB/Hz
Extinction Ratio (Dynamic)	ER	9	13		dB
Total Tx Jitter	TJ		40	80	ps
Reset Threshold ³⁾	V_{TH}	2.5	2.75	2.99	V
Reset Time Out ³⁾	t_{RES}	140	240	560	ms
Rise Time, 20% - 80%	t_R			150	ps
Supply Current			45	65	mA

¹⁾ Into multimode fiber, 62.5 μ m or 50 μ m diameter.

²⁾ Fibre Channel PI Standard.

³⁾ Laser power is shut down if power supply is below V_{TH} and switched on if power supply is above V_{TH} after t_{RES} .

Receiver Electro-Optical Characteristics

Receiver	Symbol	Limit Values			Unit
		min.	typ.	max.	
Sensitivity (Average Power) ¹⁾ 2.125 Gbit/s 1.25/1.0625 Gbit/s	P_{IN}		-18.5 -19.5	-16 -17	dBm
Saturation (Average Power)	P_{SAT}	0			dBm
Min. Optical Modulation Amplitude ²⁾ 2.125 Gbit/s 1.0625 Gbit/s	OMA		24 19	49 31	μ W
Stressed Receiver Sensitivity 50 μ m Fiber ³⁾ 2.125 Gbit/s 1.0625 Gbit/s	SPIN 50 μ m		29 24	96 55	μ W

Receiver Electro-Optical Characteristics (cont'd)

Receiver	Symbol	Limit Values			Unit
		min.	typ.	max.	
Stressed Receiver Sensitivity 62.5 μm Fiber ³⁾ 2.125 Gbit/s 1.0625 Gbit/s	SPIN 62.5 μm		34 32	109 67	μW
Loss Of Signal (LOS) Assert Level ⁴⁾	P_{LOSA}	-30	-25		dBm
Loss Of Signal (LOS) Deassert Level ⁵⁾	P_{LOSD}		-23	-18	dBm
Loss Of Signal (LOS) Hysteresis	P_{LOSA} $-P_{\text{LOSD}}$	0.5	2		dB
Loss Of Signal (LOS) Assert Time	t_{ASS}			100	μs
Loss Of Signal (LOS) Deassert Time	t_{DAS}			350	μs
Receiver 3 dB cut off Frequency ²⁾				2.5	GHz
Receiver 10 dB cut off Frequency ²⁾				6	GHz
Differential Data Output Voltage Swing ⁶⁾	$V_{\text{ODpk-pk}}$	500	700	1230	mV
Return Loss of Receiver	ORL	12			dB
Supply Current ⁷⁾			80	90	mA

¹⁾ Average optical power at which the BER is 1×10^{-12} . Measured with a 2^7-1 NRZ PRBS and ER = 9 dB.

²⁾ Fibre Channel PI Standard.

³⁾ Measured at the given Stressed Receiver Eye Closure Penalty and DCD component given in Fibre Channel PI Standard (2.03/2.18 dB & 40/80 ps).

⁴⁾ An increase in optical power above the specified level will cause the LOS output to switch from a high state to a low state.

⁵⁾ A decrease in optical power below the specified level will cause the LOS to change from a low state to a high state.

⁶⁾ AC/AC for data. Load 50Ω to GND or 100Ω differential. For dynamic measurement a tolerance of 50 mV should be added.

⁷⁾ Supply current excluding Rx output load.

Timing of Control and Status I/O

Parameter	Symbol	Limit Values		Unit	Condition
		min.	max.		
Tx Disable Assert Time	t_off		10	μs	Time from rising edge of Tx Disable to when the optical output falls below 10% of nominal.
Tx Disable Negate Time	t_on		1	ms	Time from falling edge of Tx Disable to when the modulated optical output rises above 90% of nominal.
Time to Initialize, Including Reset of Tx Fault	t_init		300		From power on or negation of Tx Fault using Tx Disable.
Tx Fault Assert Time	t_fault		100	μs	Time from fault to Tx Fault on.
Tx Disable to Reset	t_reset	10			Time Tx Disable must be held high to reset Tx Fault.
LOS Assert Time	t_loss_on		100		Time from LOS state to Rx LOS assert.
LOS Deassert Time	t_loss_off		100		Time from non-LOS state to Rx LOS deassert.
I ² C Bus Clock Rate	f_i2cbus_clock		100	kHz	

Eye Safety

This laser based single mode transceiver is a Class 1 product. It complies with IEC 60825-1 and FDA 21 CFR 1040.10 and 1040.11.

To meet laser safety requirements the transceiver shall be operated within the Absolute Maximum Ratings.

Attention: All adjustments have been made at the factory prior to shipment of the devices. No maintenance or alteration to the device is required. Tampering with or modifying the performance of the device will result in voided product warranty.

Note: Failure to adhere to the above restrictions could result in a modification that is considered an act of “manufacturing”, and will require, under law, recertification of the modified product with the U.S. Food and Drug Administration (ref. 21 CFR 1040.10 (i)).

Laser Data

Wavelength	850 nm
Total Output Power (as defined by IEC: 7 mm aperture at 14 mm distance)	< 675 μ W
Total Output Power (as defined by FDA: 7 mm aperture at 20 cm distance)	< 70 μ W
Beam Divergence	12°

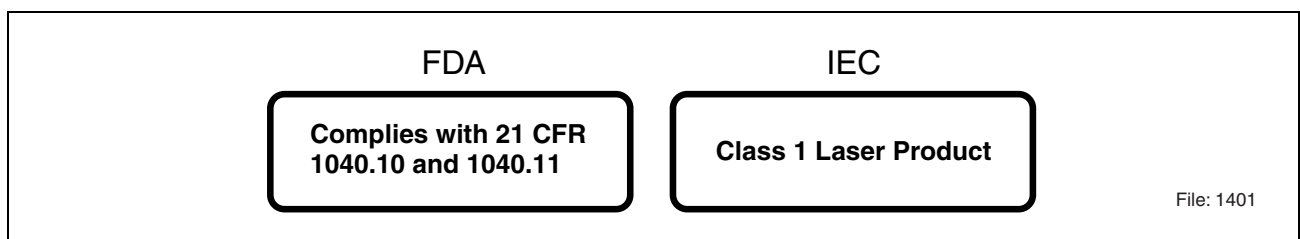

Figure 3 Required Labels

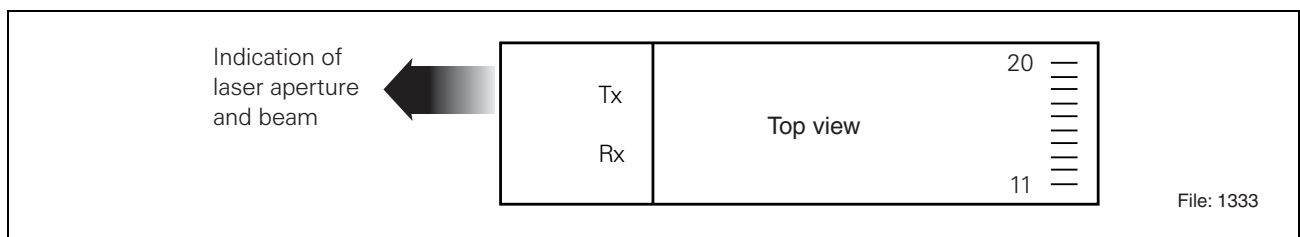

Figure 4 Laser Emission

Application Notes

EMI-Recommendations

To avoid electromagnetic radiation exceeding the required limits please take note of the following recommendations.

When Gigabit switching components are found on a PCB (multiplexers, clock recoveries etc.) any opening of the chassis may produce radiation also at chassis slots other than that of the device itself. Thus every mechanical opening or aperture should be as small as possible.

On the board itself every data connection should be an impedance matched line (e.g. strip line, coplanar strip line). Data, Datanot should be routed symmetrically, vias should be avoided. A terminating resistor of $100\ \Omega$ should be placed at the end of each matched line. An alternative termination can be provided with a $50\ \Omega$ resistor at each (D, Dn). In DC coupled systems a thevenin equivalent $50\ \Omega$ resistance can be achieved as follows: for 3.3 V: $125\ \Omega$ to V_{CC} and $82\ \Omega$ to V_{EE} , for 5 V: $82\ \Omega$ to V_{CC} and $125\ \Omega$ to V_{EE} at Data and Datanot. Please consider whether there is an internal termination inside an IC or a transceiver.

In certain cases signal GND is the most harmful source of radiation. Connecting chassis GND and signal GND at the plate/bezel/chassis rear e.g. by means of a fiber optic transceiver/cage may result in a large amount of radiation. Even a capacitive coupling between signal GND and chassis may be harmful if it is too close to an opening or an aperture.

If a separation of signal GND and chassis GND is not planned, it is strongly recommended to provide a proper contact between signal GND and chassis GND at every location where possible. This concept is designed to avoid hotspots. Hotspots are places of highest radiation which could be generated if only a few connections between signal and chassis GND exist. Compensation currents would concentrate at these connections, causing radiation.

By use of Gigabit switching components in a design, the return path of the RF current must also be considered. Thus a split GND plane of Tx and Rx portion may result in severe EMI problems.

The cutout should be sized so that all contact springs of the cage make good contact with the face plate.

For the SFP transceiver a connection of the SFP cage pins to chassis GND is recommended. If no separate chassis GND is available on the users PCB the pins should be connected to signal GND. In this case take care of the notes above.

Please consider that the PCB may behave like a waveguide. With an ϵ_r of 4, the wavelength of the harmonics inside the PCB will be half of that in free space. In this scenario even the smallest PCBs may have unexpected resonances.

Application Notes

The SFP transceiver can be assembled onto the host board together with all cages and host board connectors complying with the SFP multi source agreement.

Infineon Proposes

Cage:

Infineon Technologies
Part Number: V23838-S5-N1

Host board connector:

Tyco Electronics
Part Number: 1367073-1

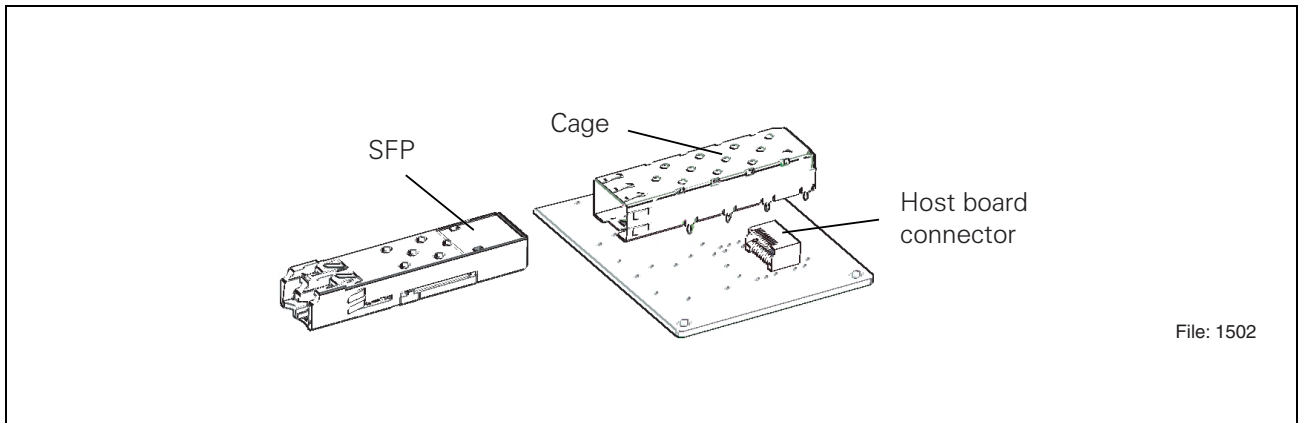

Figure 5

Handling Notes

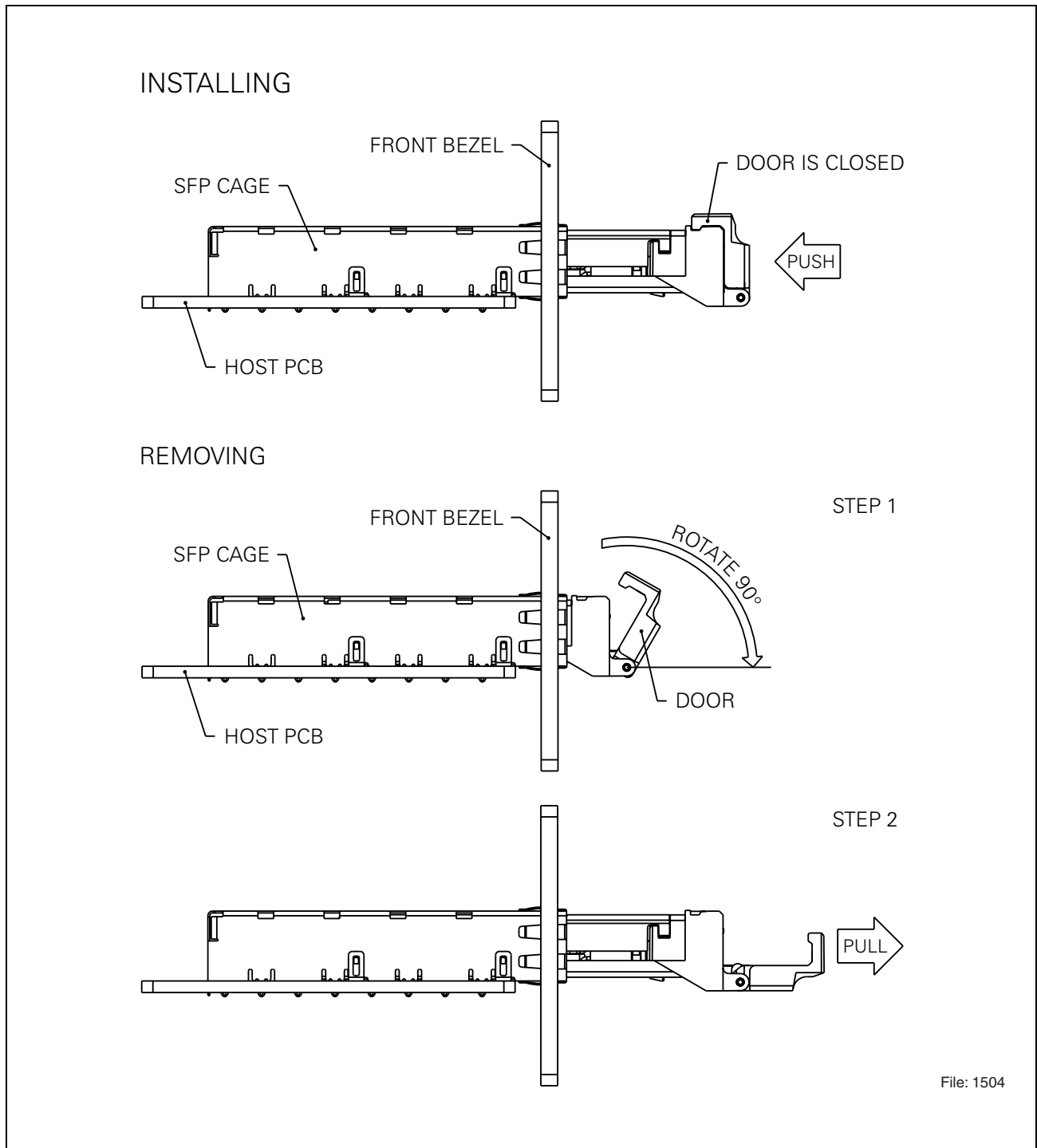

Figure 6 Installing and Removing of SFP-Transceiver

EEPROM Serial ID Memory Contents

Data Address	Hex	MSA Name/Description	Content/Value
0	03	Transceiver type	SFP
1	04	Extended identifier	Serial ID
2	07	Connector type	LC
3	00	Reserved	
4	00	SONET OC-48	
5	00	SONET OC-3/12	
6	01	Gigabit Ethernet	
7	20	FC reach/technology	
8	40	FC technology	
9	0C	FC media	
10	05	FC speed	
11	01	Encoding	
12	15	Nominal bit rate	
13	00	Reserved	
14	00	Length (9 μm) x 1 km	
15	00	Length (9 μm) x 100 m	
16	32	Length (50 μm) x 10 m	
17	0F	Length (62.5 μm) x 10 m	
18	00	Length (copper) x 1 m	
19	00	Reserved	
20 - 35		Vendor name	Infineon AG
36	00	Reserved	
37 - 39		Vendor IEEE OUI	00-03-19
40 - 55		Vendor part number	V23818-M305-B57
56		Vendor revision	Infineon production code
57 - 59		Vendor revision	1.0
60 - 61		Wavelength	850
62	00	Reserved	
63		Check code (0 to 62)	
64	00	Reserved	
65	1A	Transceiver options	Tx Disable, Tx Fault, LOS
66	69	Upper bit rate margin (%)	
67	32	Lower bit rate margin (%)	
68 - 83		Vendor serial number	
84 - 91		Vendor date code	
92 - 94		Diagnostic / SFF-8472 compliance	Not implemented
95		Check code (64-94)	
96 - 127	00	Vendor specific data	

Multimode 850 nm Fibre Channel SFP Transceiver, AC/AC TTL

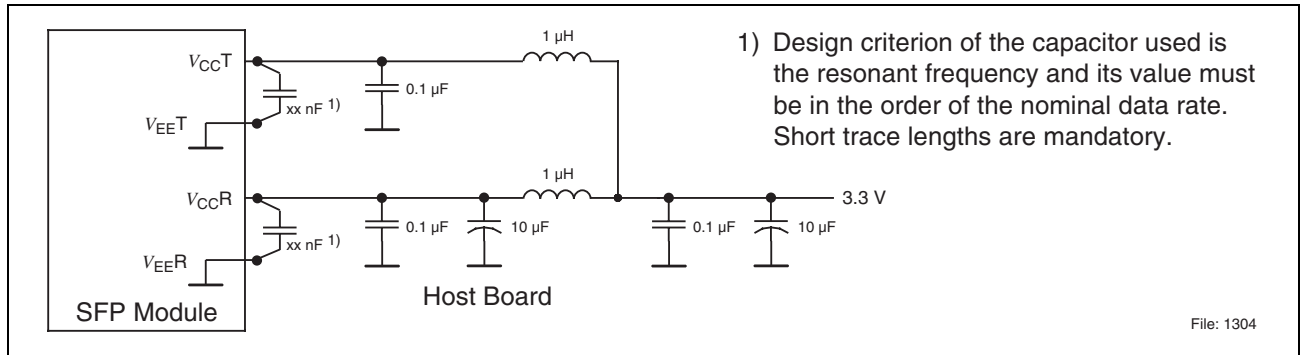

Figure 7 Recommended Host Board Supply Filtering Network

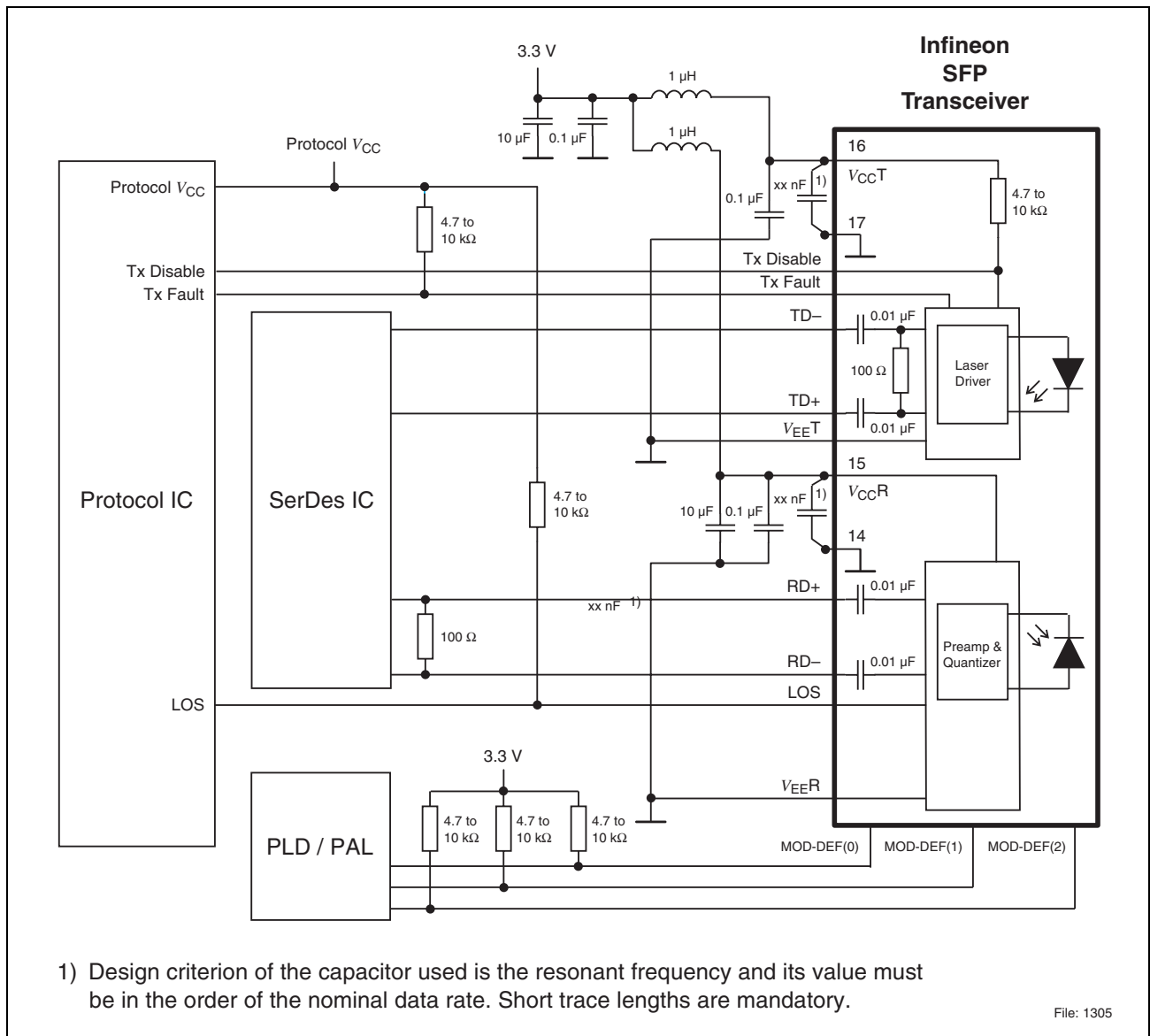

Figure 8 Example SFP Host Board Schematic

Package Outlines

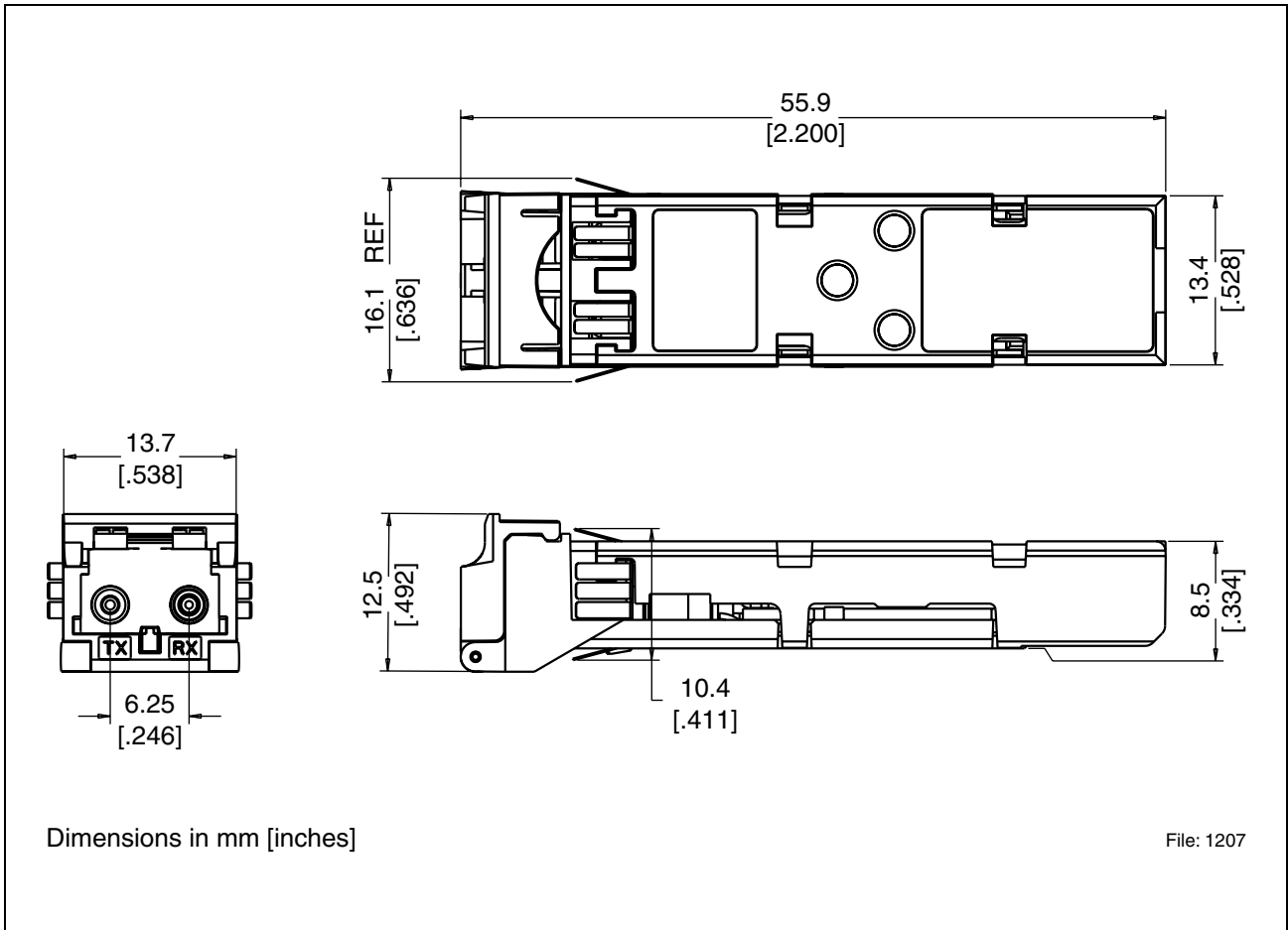

Figure 9

