

## MM74HC245A Octal 3-STATE Transceiver

### General Description

The MM74HC245A 3-STATE bidirectional buffer utilizes advanced silicon-gate CMOS technology, and is intended for two-way asynchronous communication between data buses. It has high drive current outputs which enable high speed operation even when driving large bus capacitances. This circuit possesses the low power consumption and high noise immunity usually associated with CMOS circuitry, yet has speeds comparable to low power Schottky TTL circuits.

This device has an active LOW enable input  $\overline{G}$  and a direction control input, DIR. When DIR is HIGH, data flows from the A inputs to the B outputs. When DIR is LOW, data flows from the B inputs to the A outputs. The MM74HC245A transfers true data from one bus to the other.

This device can drive up to 15 LS-TTL Loads, and does not have Schmitt trigger inputs. All inputs are protected from damage due to static discharge by diodes to  $V_{CC}$  and ground.

### Features

- Typical propagation delay: 13 ns
- Wide power supply range: 2–6V
- Low quiescent current: 80  $\mu$ A maximum (74 HC)
- 3-STATE outputs for connection to bus oriented systems
- High output drive: 6 mA (minimum)
- Same as the 645

### Ordering Code:

Order Number	Package Number	Package Description
MM74HC245AWM	M20B	20-Lead Small Outline Integrated Circuit (SOIC), JEDEC MS-013, 0.300" Wide
MM74HC245ASJ	M20D	20-Lead Small Outline Package (SOP), EIAJ TYPE II, 5.3mm Wide
MM74HC245AMTC	MTC20	20-Lead Thin Shrink Small Outline Package (TSSOP), JEDEC MO-153, 4.4mm Wide
MM74HC245AN	N20A	20-Lead Plastic Dual-In-Line Package (PDIP), JEDEC MS-001, 0.300" Wide

Devices also available in Tape and Reel. Specify by appending the suffix letter "X" to the ordering code.

### Connection Diagram

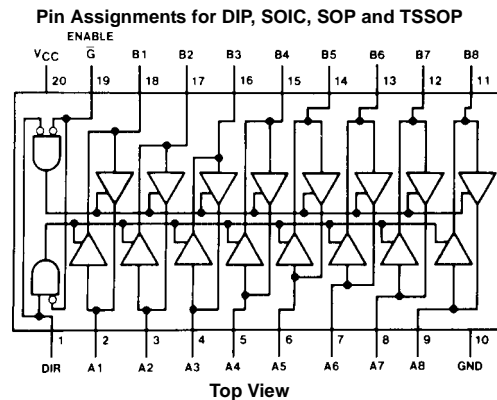

### Truth Table

Control Inputs		Operation
$\overline{G}$	DIR	
L	L	B data to A bus
L	H	A data to B bus
H	X	Isolation

H = HIGH Level  
L = LOW Level  
X = Irrelevant

Logic Diagram

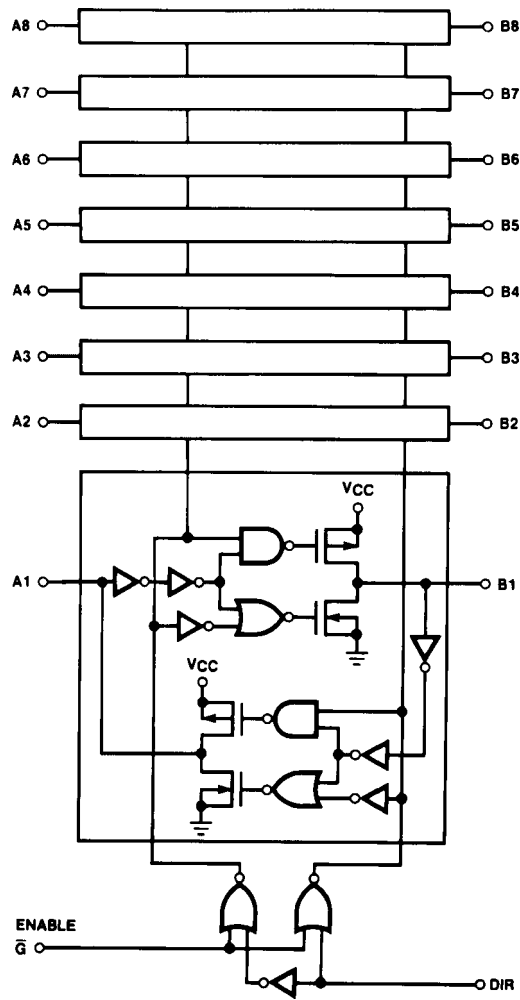

**Absolute Maximum Ratings**(Note 1)

(Note 2)

Supply Voltage ( $V_{CC}$ )	-0.5 to +7.0V
DC Input Voltage DIR and $\bar{G}$ pins ( $V_{IN}$ )	-1.5 to $V_{CC} + 1.5V$
DC Input/Output Voltage ( $V_{IN}, V_{OUT}$ )	-0.5 to $V_{CC} + 0.5V$
Clamp Diode Current ( $I_{CD}$ )	$\pm 20$ mA
DC Output Current, per pin ( $I_{OUT}$ )	$\pm 35$ mA
DC $V_{CC}$ or GND Current, per pin ( $I_{CC}$ )	$\pm 70$ mA
Storage Temperature Range ( $T_{STG}$ )	-65°C to +150°C
Power Dissipation ( $P_D$ )	
(Note 3)	600 mW
S.O. Package only	500 mW
Lead Temperature ( $T_L$ )	
(Soldering 10 seconds)	260°C

**Recommended Operating Conditions**

	Min	Max	Units
Supply Voltage ( $V_{CC}$ )	2	6	V
DC Input or Output Voltage ( $V_{IN}, V_{OUT}$ )	0	$V_{CC}$	V
Operating Temperature Range ( $T_A$ )	-40	+85	°C
Input Rise/Fall Times ( $t_r, t_f$ ) $V_{CC} = 2.0V$		1000	ns
$V_{CC} = 4.5V$		500	ns
$V_{CC} = 6.0V$		400	ns

**Note 1:** Maximum Ratings are those values beyond which damage to the device may occur.**Note 2:** Unless otherwise specified all voltages are referenced to ground.**Note 3:** Power Dissipation temperature derating — plastic "N" package: - 12 mW/°C from 65°C to 85°C.**DC Electrical Characteristics** (Note 4)

Symbol	Parameter	Conditions	$V_{CC}$	$T_A = 25^\circ C$			$T_A = -40$ to $85^\circ C$			Units
				Typ	Guaranteed Limits		Guaranteed Limits		Guaranteed Limits	
$V_{IH}$	Minimum HIGH Level Input Voltage		2.0V		1.5	1.5	1.5	1.5	V	
			4.5V		3.15	3.15	3.15	3.15	V	
			6.0V		4.2	4.2	4.2	4.2	V	
$V_{IL}$	Maximum LOW Level Input Voltage		2.0V		0.5	0.5	0.5	0.5	V	
			4.5V		1.35	1.35	1.35	1.35	V	
			6.0V		1.8	1.8	1.8	1.8	V	
$V_{OH}$	Minimum HIGH Level Output Voltage	$V_{IN} = V_{IH}$ or $V_{IL}$ $ I_{OUT}  \leq 20 \mu A$	2.0V	2.0	1.9	1.9	1.9	1.9	V	
			4.5V	4.5	4.4	4.4	4.4	4.4	V	
			6.0V	6.0	5.9	5.9	5.9	5.9	V	
		$V_{IN} = V_{IH}$ or $V_{IL}$ $ I_{OUT}  \leq 6.0$ mA $ I_{OUT}  \leq 7.8$ mA	4.5V	4.2	3.98	3.84	3.7	3.7	V	
			6.0V	5.7	5.48	5.34	5.2	5.2	V	
$V_{OL}$	Maximum LOW Level Output Voltage	$V_{IN} = V_{IH}$ or $V_{IL}$ $ I_{OUT}  \leq 20 \mu A$	2.0V	0	0.1	0.1	0.1	0.1	V	
			4.5V	0	0.1	0.1	0.1	0.1	V	
			6.0V	0	0.1	0.1	0.1	0.1	V	
		$V_{IN} = V_{IH}$ or $V_{IL}$ $ I_{OUT}  \leq 6.0$ mA $ I_{OUT}  \leq 7.8$ mA	4.5V	0.2	0.26	0.33	0.4	0.4	V	
			6.0V	0.2	0.26	0.33	0.4	0.4	V	
$I_{IN}$	Input Leakage Current ( $\bar{G}$ and DIR)	$V_{IN} = V_{CC}$ to GND	6.0V		$\pm 0.1$	$\pm 1.0$	$\pm 1.0$	$\mu A$		
$I_{OZ}$	Maximum 3-STATE Output Leakage Current	$V_{OUT} = V_{CC}$ or GND Enable $\bar{G} = V_{IH}$	6.0V		$\pm 0.5$	$\pm 5.0$	$\pm 10$	$\mu A$		
$I_{CC}$	Maximum Quiescent Supply Current	$V_{IN} = V_{CC}$ or GND $I_{OUT} = 0 \mu A$	6.0V		8.0	80	160	$\mu A$		

**Note 4:** For a power supply of  $5V \pm 10\%$  the worst case output voltages ( $V_{OH}$ , and  $V_{OL}$ ) occur for HC at 4.5V. Thus the 4.5V values should be used when designing with this supply. Worst case  $V_{IH}$  and  $V_{IL}$  occur at  $V_{CC} = 5.5V$  and 4.5V respectively. (The  $V_{IH}$  value at 5.5V is 3.85V.) The worst case leakage current ( $I_{IN}$ ,  $I_{CC}$ , and  $I_{OZ}$ ) occur for CMOS at the higher voltage and so the 6.0V values should be used.

## AC Electrical Characteristics

$V_{CC} = 5V$ ,  $T_A = 25^\circ C$ ,  $t_r = t_f = 6ns$

Symbol	Parameter	Conditions	Typ	Guaranteed Limit	Units
$t_{PHL}$ , $t_{PLH}$	Maximum Propagation Delay	$C_L = 45 pF$	12	17	ns
$t_{PZH}$ , $t_{PZL}$	Maximum Output Enable Time	$R_L = 1 k\Omega$ $C_L = 45 pF$	24	35	ns
$t_{PHZ}$ , $t_{PLZ}$	Maximum Output Disable Time	$R_L = 1 k\Omega$ $C_L = 5 pF$	18	25	ns

## AC Electrical Characteristics

$V_{CC} = 2.0V$  to  $6.0V$ ,  $C_L = 50 pF$ ,  $t_r = t_f = 6ns$  (unless otherwise specified)

Symbol	Parameter	Conditions	$V_{CC}$	$T_A = 25^\circ C$		$T_A = -40$ to $85^\circ C$		$T_A = -55$ to $125^\circ C$		Units				
				Typ	Guaranteed Limits	Typ	Guaranteed Limits	Typ	Guaranteed Limits					
$t_{PHL}$ , $t_{PLH}$	Maximum Propagation Delay	$C_L = 50 pF$	2.0V	31	90	113	135	ns						
		$C_L = 150 pF$	2.0V	41	96	116	128	ns						
		$C_L = 50 pF$	4.5V	13	18	23	27	ns						
		$C_L = 150 pF$	4.5V	17	22	28	33	ns						
		$C_L = 50 pF$	6.0V	11	15	19	23	ns						
		$C_L = 150 pF$	6.0V	14	19	23	28	ns						
$t_{PZH}$ , $t_{PZL}$	Maximum Output Enable Time	$R_L = 1 k\Omega$	2.0V	71	190	240	285	ns						
		$C_L = 50 pF$												
		$C_L = 150 pF$							2.0V	81	240	300	360	ns
		$C_L = 50 pF$							4.5V	26	38	48	57	ns
		$C_L = 150 pF$							4.5V	31	48	60	72	ns
		$C_L = 50 pF$							6.0V	21	32	41	48	ns
$t_{PHZ}$ , $t_{PLZ}$	Maximum Output Disable Time	$R_L = 1 k\Omega$	2.0V	39	135	169	203	ns						
		$C_L = 50 pF$	4.5V	20	27	34	41	ns						
			6.0V	18	23	29	34	ns						
$t_{TLH}$ , $t_{THL}$	Output Rise and Fall Time	$C_L = 50 pF$	2.0V	20	60	75	90	ns						
			4.5V	6	12	15	18	ns						
			6.0V	5	10	13	15	ns						
$C_{PD}$	Power Dissipation Capacitance (Note 5)	$\bar{G} = V_{IL}$ $\bar{G} = V_{IH}$		50				pF						
				5				pF						
$C_{IN}$	Maximum Input Capacitance			5	10	10	10	pF						
$C_{IN/OUT}$	Maximum Input/Output Capacitance, A or B			15	20	20	20	pF						

**Note 5:**  $C_{PD}$  determines the no load dynamic power consumption,  $P_D = C_{PD} V_{CC}^2 f + I_{CC} V_{CC}$ , and the no load dynamic current consumption,  $I_S = C_{PD} V_{CC} f + I_{CC}$ .

**Physical Dimensions** inches (millimeters) unless otherwise noted



**20-Lead Small Outline Integrated Circuit (SOIC), JEDEC MS-013, 0.300" Wide  
Package Number M20B**

**Physical Dimensions** inches (millimeters) unless otherwise noted (Continued)



LAND PATTERN RECOMMENDATION



DIMENSIONS ARE IN MILLIMETERS



DETAIL A

NOTES:

- A. CONFORMS TO EIAJ EDR-7320 REGISTRATION, ESTABLISHED IN DECEMBER, 1998.
- B. DIMENSIONS ARE IN MILLIMETERS.
- C. DIMENSIONS ARE EXCLUSIVE OF BURRS, MOLD FLASH, AND TIE BAR EXTRUSIONS.

M20DRevB1

**20-Lead Small Outline Package (SOP), EIAJ TYPE II, 5.3mm Wide Package Number M20D**

**Physical Dimensions** inches (millimeters) unless otherwise noted (Continued)

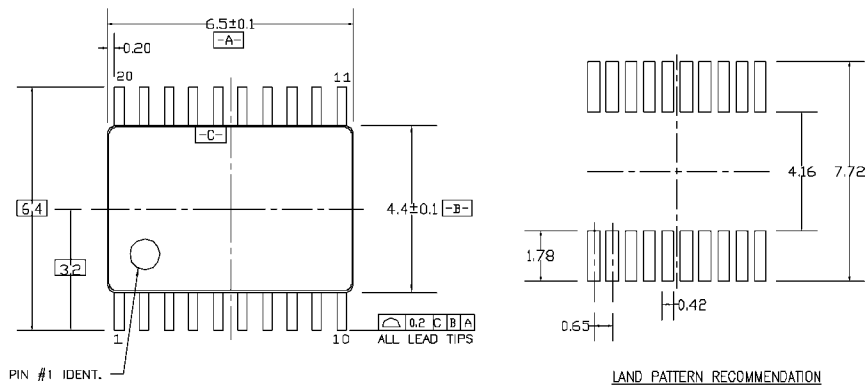

PIN #1 IDENT.

LAND PATTERN RECOMMENDATION

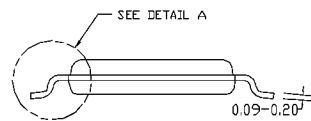
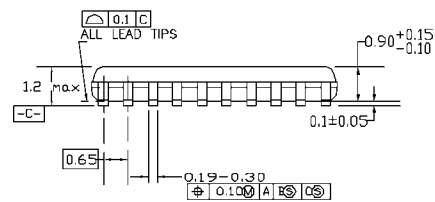

DIMENSIONS ARE IN MILLIMETERS

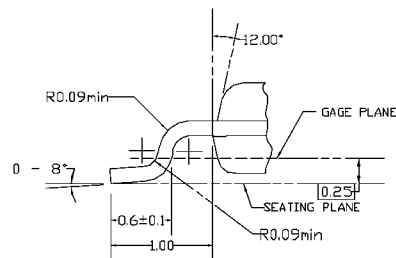

DETAIL A

NOTES:

- A. CONFORMS TO JEDEC REGISTRATION MO-153, VARIATION AC, REF NOTE 6, DATE 7/93.
- B. DIMENSIONS ARE IN MILLIMETERS.
- C. DIMENSIONS ARE EXCLUSIVE OF BURRS, MOLDS FLASH, AND TIE BAR EXTRUSIONS.
- D. DIMENSIONS AND TOLERANCES PER ANSI Y14.5M, 1982.

MTC20REVD1

**20-Lead Thin Shrink Small Outline Package (TSSOP), JEDEC MO-153, 4.4mm Wide  
Package Number MTC20**

**Physical Dimensions** inches (millimeters) unless otherwise noted (Continued)

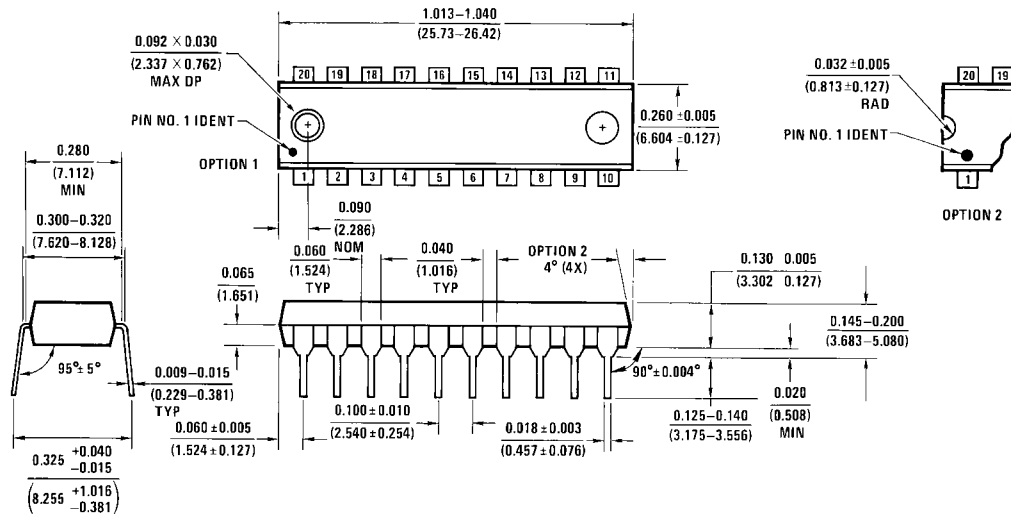

20-Lead Plastic Dual-In-Line Package (PDIP), JEDEC MS-001, 0.300" Wide  
Package Number N20A

N20A (REV G)

Fairchild does not assume any responsibility for use of any circuitry described, no circuit patent licenses are implied and Fairchild reserves the right at any time without notice to change said circuitry and specifications.

**LIFE SUPPORT POLICY**

FAIRCHILD'S PRODUCTS ARE NOT AUTHORIZED FOR USE AS CRITICAL COMPONENTS IN LIFE SUPPORT DEVICES OR SYSTEMS WITHOUT THE EXPRESS WRITTEN APPROVAL OF THE PRESIDENT OF FAIRCHILD SEMICONDUCTOR CORPORATION. As used herein:

1. Life support devices or systems are devices or systems which, (a) are intended for surgical implant into the body, or (b) support or sustain life, and (c) whose failure to perform when properly used in accordance with instructions for use provided in the labeling, can be reasonably expected to result in a significant injury to the user.
2. A critical component in any component of a life support device or system whose failure to perform can be reasonably expected to cause the failure of the life support device or system, or to affect its safety or effectiveness.

[www.fairchildsemi.com](http://www.fairchildsemi.com)