



## DCV01 Series

For most current data sheet and other product information, visit [www.burr-brown.com](http://www.burr-brown.com)

# Miniature, 1W, 1500Vrms Isolated UNREGULATED DC/DC CONVERTERS

## FEATURES

- UP TO 85% EFFICIENCY
- THERMAL PROTECTION
- DEVICE-TO-DEVICE SYNCHRONIZATION
- SHORT CIRCUIT PROTECTION
- EN55022 CLASS B EMC PERFORMANCE
- UL1950 RECOGNIZED COMPONENT
- JEDEC PDIP-14 AND GULL-WING PACKAGES

## APPLICATIONS

- INDUSTRIAL CONTROL AND INSTRUMENTATION
- POINT-OF-USE POWER CONVERSION
- GROUND LOOP ELIMINATION
- DATA ACQUISITION
- TEST EQUIPMENT
- SECONDARY ISOLATION CIRCUITS

## DESCRIPTION

The DCV01 series is a family of 1W, 1500Vrms isolated, unregulated, isolated DC/DC converters. Requiring a minimum of external components and including on-chip device protection, the DCV01 series provides extra features such as output disable and synchronization of switching frequencies.

The use of a highly integrated package design results in highly reliable products with a power density of 40W/in<sup>3</sup> (2.4W/cm<sup>3</sup>). This combination of features high isolation and small size makes the DCV01 suitable for a wide range of applications.

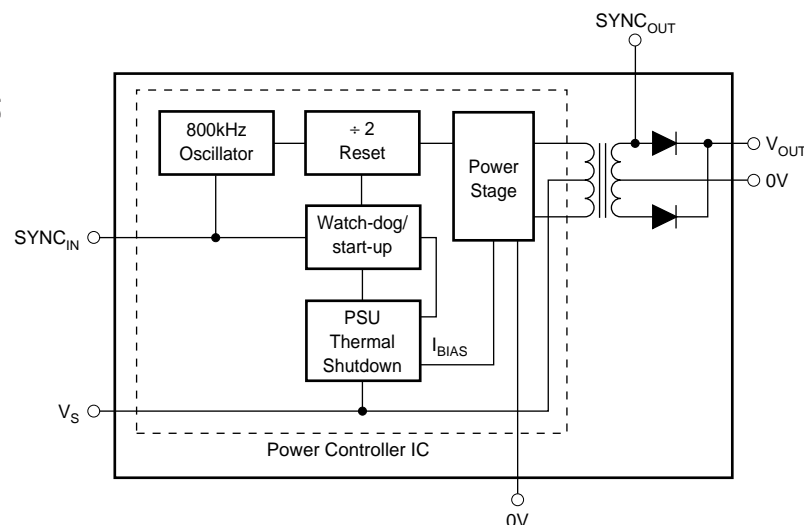

International Airport Industrial Park • Mailing Address: PO Box 11400, Tucson, AZ 85734 • Street Address: 6730 S. Tucson Blvd., Tucson, AZ 85706 • Tel: (520) 746-1111  
Twx: 910-952-1111 • Internet: <http://www.burr-brown.com/> • Cable: BBRCORP • Telex: 066-6491 • FAX: (520) 889-1510 • Immediate Product Info: (800) 548-6132

# SPECIFICATIONS

At  $T_A = +25^\circ\text{C}$ , unless otherwise specified.

PARAMETER	CONDITIONS	DCV01 SERIES			UNITS
		MIN	TYP	MAX	
<b>OUTPUT</b> Power Ripple Voltage vs Temp	100% Full Load O/P Capacitor = $1\mu\text{F}$ , 50% Load Room to Cold Room to Hot		0.97 20 0.046 0.016		W mVp-p %/°C %/°C
<b>INPUT</b> Voltage Range on $V_S$		-10		10	%
<b>ISOLATION</b> Voltage	1s Flash Test 60s Test, UL1950 <sup>(1)</sup>	1.5 1.5			kVrms kVrms
<b>LINE</b> Regulation			1		%/1% of $V_S$
<b>SWITCHING/SYNCHRONIZATION</b> Oscillator Frequency ( $f_{\text{OSC}}$ ) Sync Input Low Sync Input Current Disable Time Capacitance Loading on $\text{SYNC}_{\text{IN}}$ Pin	Switching Frequency = $f_{\text{OSC}}/2$  $V_{\text{SYNC}} = +2\text{V}$  External	0	800 75 2	0.4 3	kHz V $\mu\text{A}$ $\mu\text{s}$ pF
<b>RELIABILITY</b> Demonstrated	$T_A = +55^\circ\text{C}$			75	FITS
<b>THERMAL SHUTDOWN</b> IC Temperature at Shutdown Shutdown Current			150 3		°C mA
<b>TEMPERATURE RANGE</b> Operating		-40		+85	°C

PRODUCT	INPUT VOLTAGE (V)			OUTPUT VOLTAGE (V)			LOAD REGULATION (%)		NO LOAD CURRENT (mA)	EFFICIENCY (%)	BARRIER CAPACITANCE (pF)	LEAKAGE CURRENT ( $\mu\text{A}$ )
	$V_S$			$V_{\text{NOM}}$					$I_Q$		$C_{\text{ISO}}$	
				75% LOAD <sup>(2)</sup>			10% TO 100% LOAD <sup>(3)</sup>		0% LOAD	100% LOAD	$V_{\text{ISO}} = 750\text{Vrms}$	$V_{\text{ISO}} = 750\text{Vrms}$
	MIN	TYP	MAX	MIN	TYP	MAX	TYP	MAX	TYP	TYP	TYP	TYP
DCV010505	4.5	5	5.5	4.75	5	5.25	19	31	20	80	3.6	0.9
DCV010505D	4.5	5	5.5	$\pm 4.75$	$\pm 5$	$\pm 5.25$	19	32	23	80	3.8	0.9
DCV010512	4.5	5	5.5	11.4	12	12.6	23	38	30	85	5.1	1.2
DCV010512D	4.5	5	5.5	$\pm 11.4$	$\pm 12$	$\pm 12.6$	19	37	40	82	4.0	1.0
DCV010515	4.5	5	5.5	14.25	15	15.75	30	50	34	84	3.8	0.9
DCV010515D	4.5	5	5.5	$\pm 14.25$	$\pm 15$	$\pm 15.75$	27	50	42	85	4.7	1.1
DCV011512D <sup>(4)</sup>	13.5	15	16.5	$\pm 11.4$	$\pm 12$	$\pm 12.6$	11	39	19	78	4.2	1.0
DCV011515D <sup>(4)</sup>	13.5	15	16.5	$\pm 14.25$	$\pm 15$	$\pm 15.75$	12	39	20	79	4.2	1.0
DCV012405 <sup>(4)</sup>	21.6	24	26.4	4.75	5	5.25	13	23	14	77	3.8	0.9
DCV012415D <sup>(4)</sup>	21.6	24	26.4	$\pm 14.25$	$\pm 15$	$\pm 15.75$	12	35	17	76	5.3	1.3

NOTES: (1) During UL1950 recognition tests only, UL File #E199929. (2) 100% Load Current =  $1\text{W}/V_{\text{NOM}}$  TYP. (3) Load regulation =  $(V_{\text{OUT}} \text{ at } 10\% - V_{\text{OUT}} \text{ at } 100\%) / V_{\text{OUT}} \text{ at } 75\%$ . (4) Scheduled availability Q3 2000.

The information provided herein is believed to be reliable; however, BURR-BROWN assumes no responsibility for inaccuracies or omissions. BURR-BROWN assumes no responsibility for the use of this information, and all use of such information shall be entirely at the user's own risk. Prices and specifications are subject to change without notice. No patent rights or licenses to any of the circuits described herein are implied or granted to any third party. BURR-BROWN does not authorize or warrant any BURR-BROWN product for use in life support devices and/or systems.

## ABSOLUTE MAXIMUM RATINGS

Input Voltage:	
5V Input Models .....	7V
15V Input Models .....	18V
24V Input Models .....	29V
Storage Temperature .....	-60°C to +125°C
Lead Temperature (soldering, 10s) .....	270°C



## ELECTROSTATIC DISCHARGE SENSITIVITY

This integrated circuit can be damaged by ESD. Burr-Brown recommends that all integrated circuits be handled with appropriate precautions. Failure to observe proper handling and installation procedures can cause damage.

ESD damage can range from subtle performance degradation to complete device failure. Precision integrated circuits may be more susceptible to damage because very small parametric changes could cause the device not to meet its published specifications.

## ORDERING INFORMATION

Basic Model Number: 1W Product	DCV01	05	05	(D)	( )
Voltage Input:					
5V In					
Voltage Output:					
5V Out					
Dual Output:					
Package Code:					
P = PDIP-14					
P-U = PDIP-14 Gull-Wing					

## PACKAGE/ORDERING INFORMATION

PRODUCT	PACKAGE	PACKAGE DRAWING NUMBER	SPECIFIED TEMPERATURE RANGE	PACKAGE MARKING	ORDERING NUMBER <sup>(1)</sup>	TRANSPORT MEDIA
<b>Single</b>						
DCV010505P	DIP-14	010-1	-40°C to +85°C	DCV010505P	DCV010505P	Rails
DCV010505P-U	Gull-Wing-14	010-2	-40°C to +85°C	DCV010505P-U	DCV010505P-U/700	Tape and Reel
DCV010512P	DIP-14	010-1	-40°C to +85°C	DCV010512P	DCV010512P	Rails
DCV010512P-U	Gull-Wing-14	010-2	-40°C to +85°C	DCV010512P-U	DCV010512P-U/700	Tape and Reel
DCV010515P	DIP-14	010-1	-40°C to +85°C	DCV010515P	DCV010515P	Rails
DCV010515P-U	Gull-Wing-14	010-2	-40°C to +85°C	DCV010515P-U	DCV010515P-U/700	Tape and Reel
DCV012405P <sup>(2)</sup>	DIP-14	010-1	-40°C to +85°C	DCV012405P	DCV012405P	Tape and Reel
DCV012405P-U <sup>(2)</sup>	Gull-Wing-14	010-2	-40°C to +85°C	DCV012405P-U	DCV012405P-U/700	Rails
<b>Dual</b>						
DCV010505DP	DIP-14	010-1	-40°C to +85°C	DCV010505DP	DCV010505DP	Rails
DCV010505DP-U	Gull-Wing-14	010-2	-40°C to +85°C	DCV010505DP-U	DCV010505DP-U/700	Tape and Reel
DCV010512DP	DIP-14	010-1	-40°C to +85°C	DCV010512DP	DCV010512DP	Rails
DCV010512DP-U	Gull-Wing-14	010-2	-40°C to +85°C	DCV010512DP-U	DCV010512DP-U/700	Tape and Reel
DCV010515DP	DIP-14	010-1	-40°C to +85°C	DCV010515DP	DCV010515DP	Rails
DCV010515DP-U	Gull-Wing-14	010-2	-40°C to +85°C	DCV010515DP-U	DCV010515DP-U/700	Tape and Reel
DCV011512DP <sup>(2)</sup>	DIP-14	010-1	-40°C to +85°C	DCV011512DP	DCV011512DP	Rails
DCV011512DP-U <sup>(2)</sup>	DIP-14	010-2	-40°C to +85°C	DCV011512DP-U	DCV011512DP-U/700	Tape and Reel
DCV011515DP <sup>(2)</sup>	Gull-Wing-14	010-1	-40°C to +85°C	DCV011515DP	DCV011515DP	Rails
DCV011515DP-U <sup>(2)</sup>	DIP-14	010-2	-40°C to +85°C	DCV011515DP-U	DCV011515DP-U/700	Tape and Reel
DCV012415DP <sup>(2)</sup>	Gull-Wing-14	010-1	-40°C to +85°C	DCV012415DP	DCV012415DP	Rails
DCV012415DP-U <sup>(2)</sup>	DIP-14	010-2	-40°C to +85°C	DCV012415DP-U	DCV012415DP-U/700	Tape and Reel

NOTE: (1) Models with a slash (/) are available only in Tape and Reel in the quantities indicated (e.g., /700 indicates 700 devices per reel). Ordering 700 pieces of "DCP010505BP-U/700" will get a single 700-piece Tape and Reel. (2) Scheduled availability Q3, 2000.

### PIN CONFIGURATION (Single-DIP and Gull-Wing)

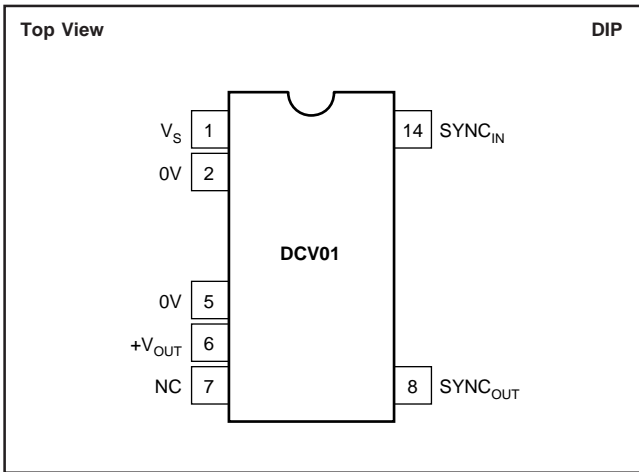

### PIN CONFIGURATION (Dual-DIP and Gull-Wing)

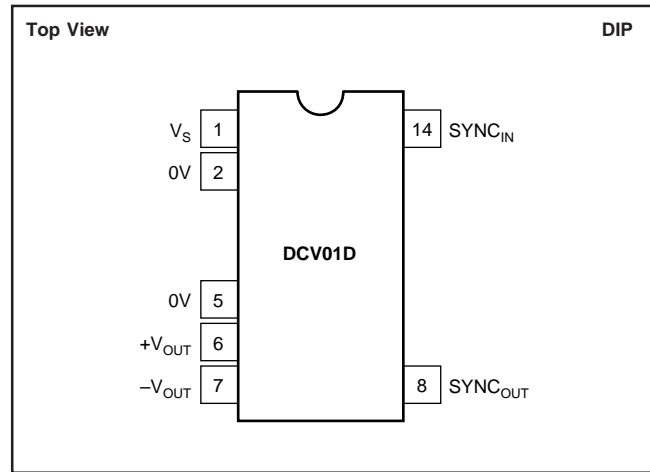

### PIN DEFINITION (Single-DIP)

PIN #	PIN NAME	DESCRIPTION
1	V <sub>S</sub>	Voltage Input
2	0V	Input Side Common
5	0V	Output Side Common
6	+V <sub>OUT</sub>	+Voltage Out
7	NC	Not Connected
8	SYNC <sub>OUT</sub>	Unrectified Transformer Output
14	SYNC <sub>IN</sub>	Synchronization Pin

### PIN DEFINITION (Dual-DIP)

PIN #	PIN NAME	DESCRIPTION
1	V <sub>S</sub>	Voltage Input
2	0V	Input Side Common
5	0V	Output Side Common
6	+V <sub>OUT</sub>	+Voltage Out
7	-V <sub>OUT</sub>	-Voltage Out
8	SYNC <sub>OUT</sub>	Unrectified Transformer Output
14	SYNC <sub>IN</sub>	Synchronization Pin

# TYPICAL PERFORMANCE CURVES

At  $T_A = +25^\circ\text{C}$ , unless otherwise noted.

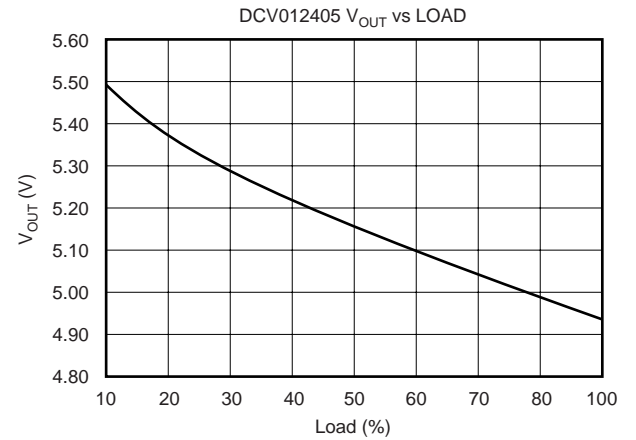
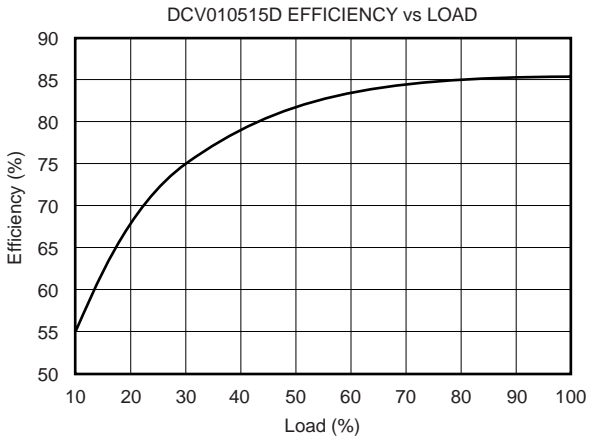
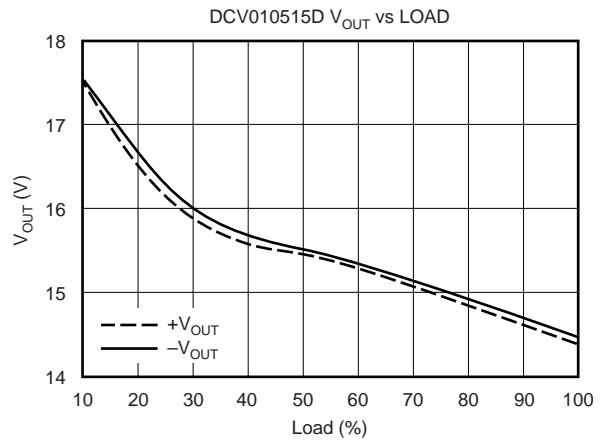
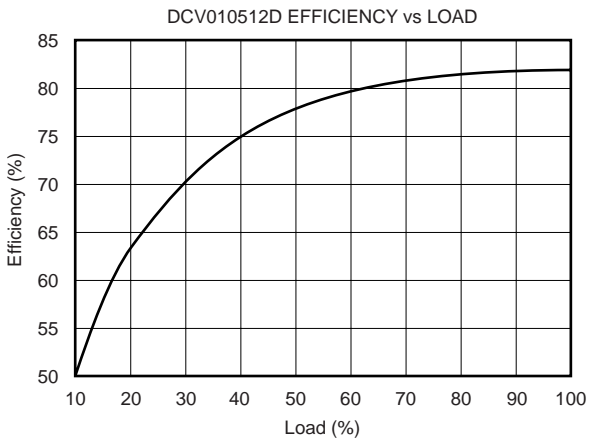
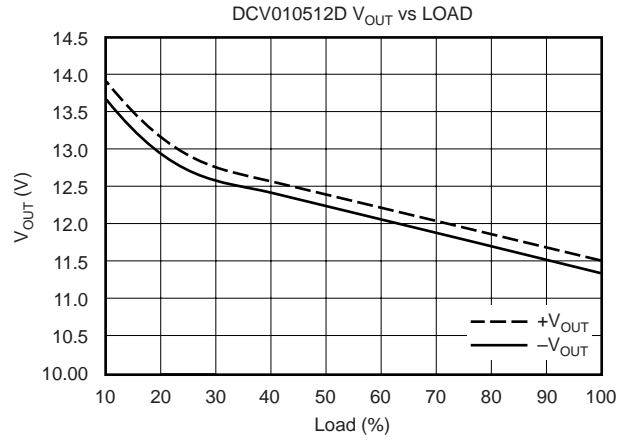
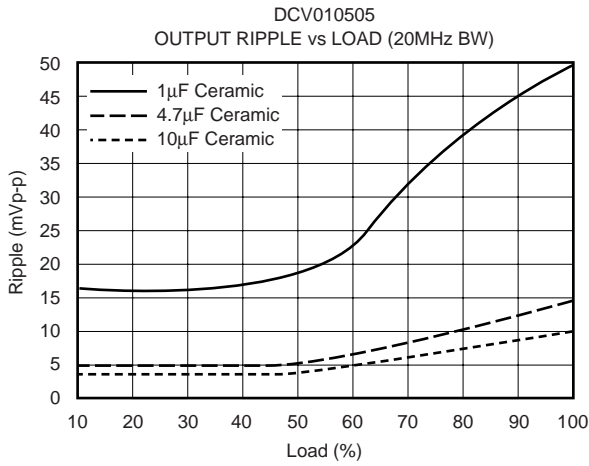

# TYPICAL PERFORMANCE CURVES (Cont.)

At  $T_A = +25^\circ\text{C}$ , unless otherwise noted.

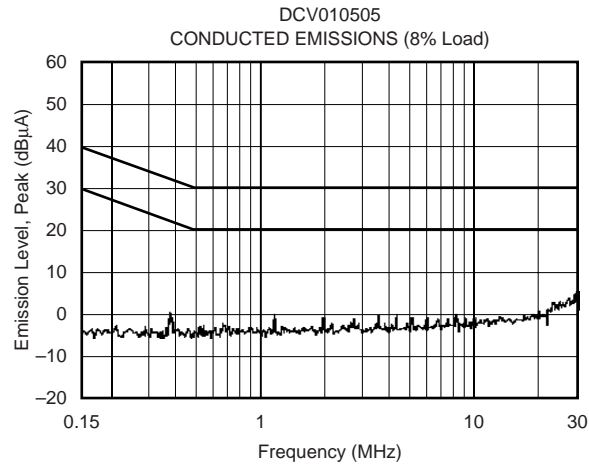
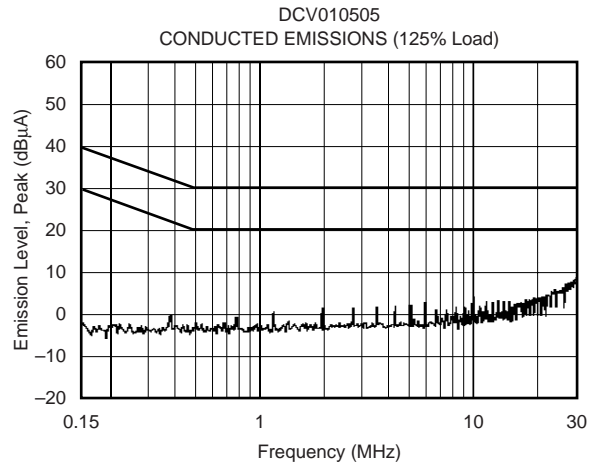
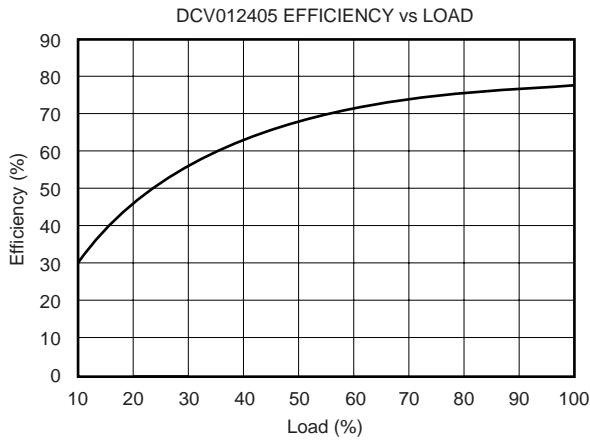

# FUNCTIONAL DESCRIPTION

## OVERVIEW

The DCV01 offers up to 1W of unregulated output power with a typical efficiency of up to 85%. This is achieved through highly integrated packaging technology and the implementation of a custom power stage and control IC. The circuit design utilizes an advanced BiCMOS/DMOS process. Separate primary and secondary transformer windings give good isolation and low barrier capacitance.

## POWER STAGE

This uses a push-pull, center-tapped topology switching at 400kHz (divide by 2 from 800kHz oscillator).

## OSCILLATOR AND WATCHDOG

The onboard 800kHz oscillator generates the switching frequency via a divide by 2 circuit. The oscillator can be synchronized to other DCV01 circuits or an external source, and is used to minimize system noise.

A watchdog circuit checks the operation of the oscillator circuit. The oscillator can be stopped by pulling the SYNC<sub>IN</sub> pin LOW. The output pins will be tri-stated. This will occur in 2μs.

## THERMAL SHUTDOWN

The DCV01 is protected by a thermal shutdown circuit. If the on-chip temperature exceeds 150°C, the device will shut down. Once the temperature falls below 150°C, normal operation will resume.

## SYNCHRONIZATION

In the event that more than one DC/DC converter is needed onboard, beat frequencies and other electrical interference can be generated. This is due to the small variations in switching frequencies between the DC/DC converters.

The DCV01 overcomes this by allowing devices to be synchronized to one another. Up to eight devices can be synchronized by connecting the SYNC<sub>IN</sub> pins together, taking care to minimize the capacitance of tracking. Stray capacitance (> 3pF) will have the effect of reducing the

switching frequency, or even stopping the oscillator circuit. If synchronized devices are used, it should be noted that, at start up, all devices will draw maximum current simultaneously. This can cause the input voltage to dip and should it dip below the minimum input voltage (4.5V), the devices may not start up. A 2.2μF capacitor should be connected close to the input pins.

If more than eight devices are to be synchronized, it is recommended that the SYNC<sub>IN</sub> pins are driven by an external device. Details are contained in a separate applications bulletin (AB-153).

## CONSTRUCTION

The DCV01's basic construction is the same as standard ICs. There is no substrate within the molded package. The DCV01 is constructed using an IC, rectifier diodes, and a wound magnetic toroid on a leadframe. As there is no solder within the package, the DCV01 does not require any special PCB assembly processing. This results in an isolated DC/DC converter with inherently high reliability.

# ADDITIONAL FUNCTIONS

## DISABLE/ENABLE

The DCV01 can be disabled or enabled by driving the SYNC pin using an open drain CMOS gate. If the SYNC<sub>IN</sub> pin is pulled low, the DCV01 will be disabled. The disable time depends upon the external loading; the internal disable function is implemented in 2μs. Removal of the pull down will cause the DCV01 to be enabled.

Capacitive loading on the SYNC<sub>IN</sub> pin should be minimized in order to prevent a reduction in the oscillator frequency.

## DECOUPLING

### Ripple Reduction

The high switching frequency of 400kHz allows simple filtering. To reduce ripple, it is recommended that at least a 1μF capacitor is used on V<sub>OUT</sub>. Dual outputs should both be decoupled to pin 5. A 2.2μF low ESR capacitor on the input of the 5V in versions, and a 0.47μF low ESR cap on the 24V DCV01 in versions is recommended.

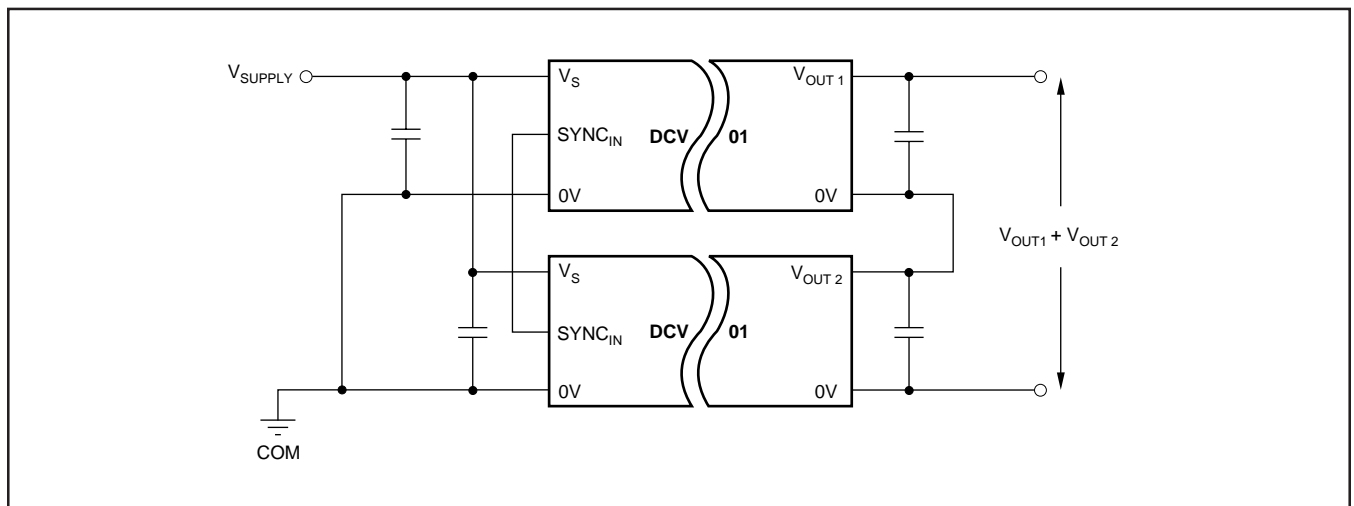

FIGURE 1. Connecting the DCV01 in Series.

## Connecting the DCV01 in Series

Multiple DCV01 isolated 1W DC/DC converters can be connected in series to provide nonstandard voltage rails. This is possible by utilizing the floating outputs provided by the DCV01's galvanic isolation.

Connect the positive  $V_{OUT}$  from one DCV01 to the negative  $V_{OUT}$  (0V) of another (see Figure 1). If the  $SYNC_{IN}$  pins are tied together, the self-synchronization feature of the DCV01 will prevent beat frequencies on the voltage rails. The  $SYNC_{IN}$  feature of the DCV01 allows easy series connection without external filtering, minimizing cost.

The outputs on dual output DCV01 versions can also be connected in series to provide two times the magnitude of  $V_{OUT}$  as shown in Figure 2. For example, a dual 15V DCV01 could be connected to provide a 30V rail.

## Connecting the DCV01 in Parallel

If the output power from one DCV01 is not sufficient, it is possible to parallel the outputs of multiple DCV01s, as shown in Figure 3. Again, the  $SYNC_{IN}$  feature allows easy synchronization to prevent power-rail beat frequencies at no additional filtering cost.

## PCB LAYOUT

### Ripple and Noise

Careful consideration should be given to the layout of the PCB in order that the best results can be obtained.

The DCV01 is a switching power supply and as such can place high peak current demands on the input supply. In order to avoid the supply falling momentarily during the fast switching pulses ground and power planes should be used to track the power to the input of DCV01. If this is not possible then the supplies must be connected in a star formation with the tracks made as wide as possible.

If the  $SYNC_{IN}$  pin is being used then the tracking between device  $SYNC_{IN}$  pins should be short to avoid stray capacitance. If the  $SYNC_{IN}$  pin is not being used it is advisable to place a guard ring, (connected to input ground) around this pin to avoid any noise pick up.

The output should be taken from the device using ground and power planes, this will ensure minimum losses.

A good quality low ESR capacitor placed as close as practicable across the input will reduce reflected ripple and ensure a smooth start up.

A good quality low ESR capacitor placed as close as practicable across the rectifier output terminal and output ground will give the best ripple and noise performance.

## THERMAL MANAGEMENT

Due to the high power density of this device it is advisable to provide ground planes on the input and output.

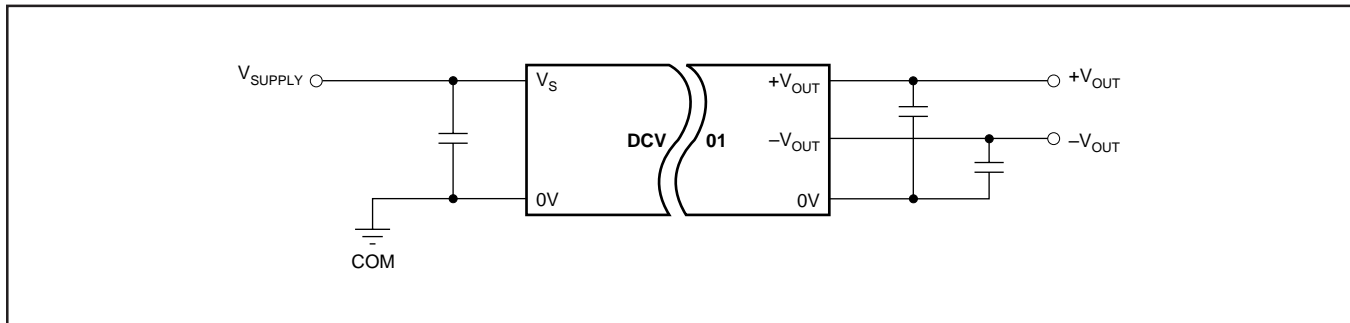

FIGURE 2. Connecting Dual Outputs in Series.

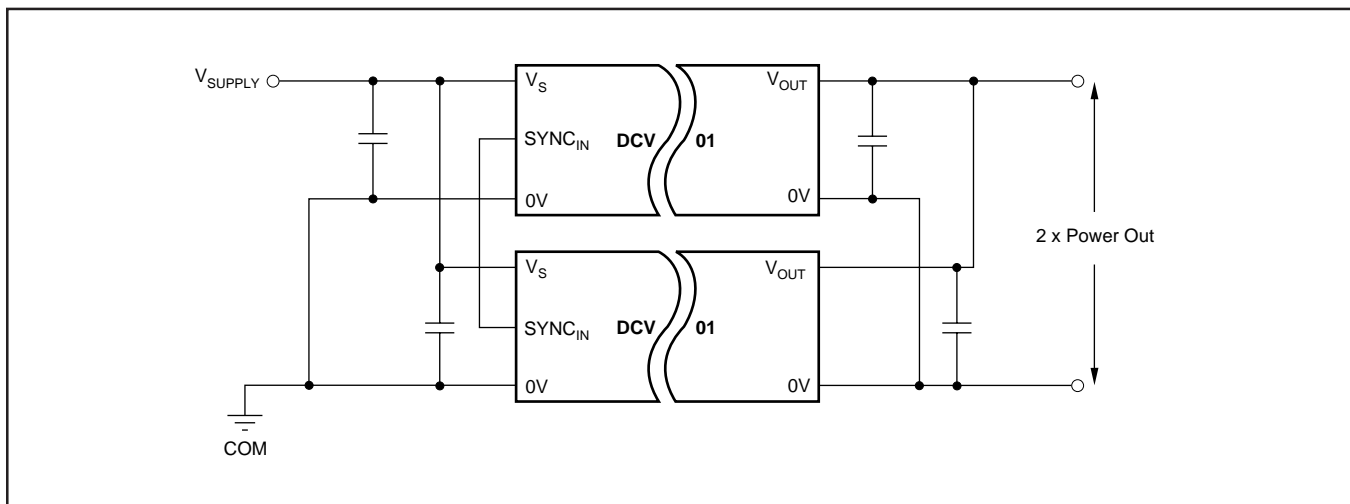

FIGURE 3. Connecting Multiple DCV01s in Parallel.