



# SBL20xxCT, SBLF20xxCT & SBLB20xxCT Series

Vishay Semiconductors  
formerly General Semiconductor

## Dual Low V<sub>F</sub> Schottky Rectifier

Reverse Voltage 30 and 40V  
Forward Current 20A

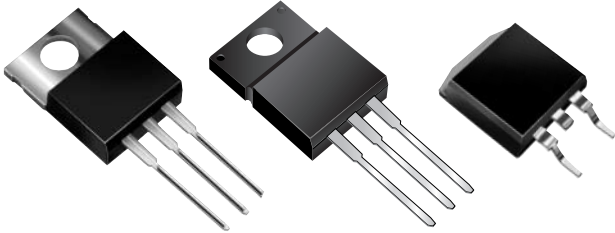

### TO-220AB (SBL20xxCT)

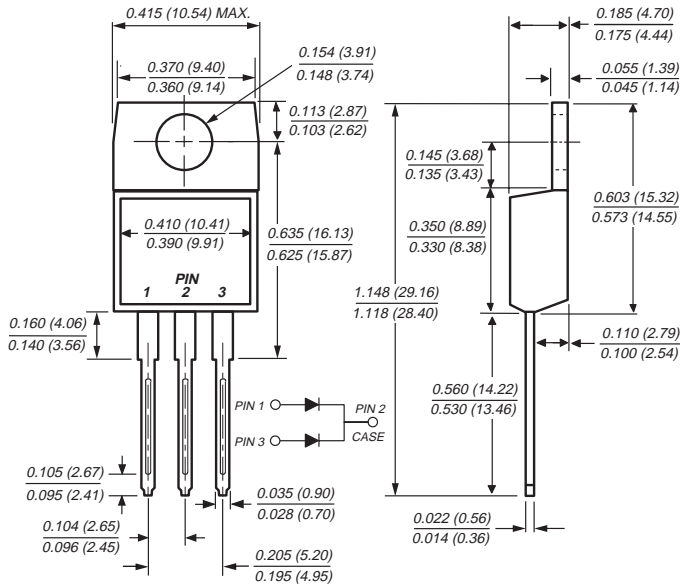

### Mounting Pad Layout TO-263AB

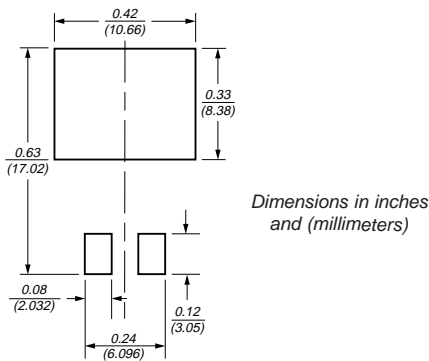

Dimensions in inches and millimeters

### ITO-220AB (SBLF20xxCT)

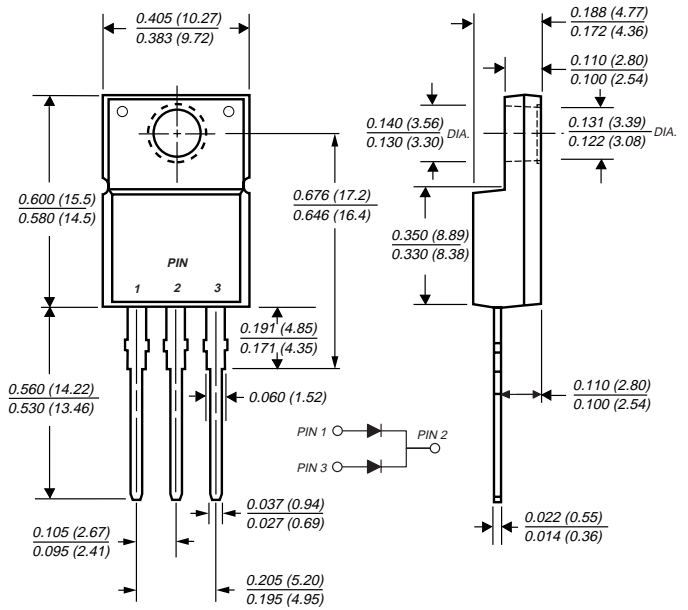

### TO-263AB (SBLB20xxCT)

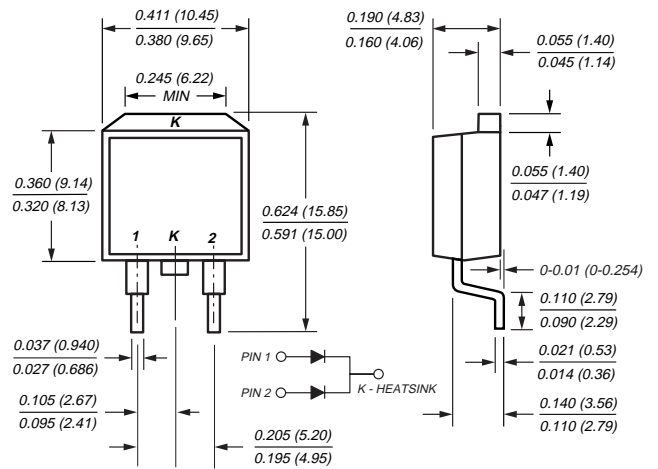

## Features

- Plastic package has Underwriters Laboratory Flammability Classification 94V-0
- Dual rectifier construction, positive center tap
- Metal silicon junction, majority carrier conduction
- Low power loss, high efficiency
- Guardring for overvoltage protection
- For use in low voltage, high frequency inverters, free wheeling, and polarity protection applications
- High temperature soldering guaranteed: 250°C/10 seconds, 0.25" (6.35mm) from case

## Mechanical Data

**Case:** JEDEC TO-220AB, ITO-220AB & TO-263AB molded plastic body

**Terminals:** Plated leads, solderable per MIL-STD-750, Method 2026

**Polarity:** As marked

**Mounting Position:** Any

**Mounting Torque:** 10 in-lbs maximum

**Weight:** 0.08 oz., 2.24 g

# SBL20xxCT, SBLF20xxCT & SBLB20xxCT Series



Vishay Semiconductors  
formerly General Semiconductor

## Maximum Ratings (T<sub>C</sub> = 25°C unless otherwise noted)

Parameter	Symbol	SBL2030CT	SBL2040CT	Unit
Maximum repetitive peak reverse voltage	V <sub>RRM</sub>	30	40	V
Working peak reverse voltage	V <sub>RWM</sub>	21	28	V
Maximum DC blocking voltage	V <sub>DC</sub>	30	40	V
Maximum average forward rectified current at T <sub>C</sub> = 105°C <i>Total device Per leg</i>	I <sub>F(AV)</sub>	20 10		A
Peak forward surge current 8.3ms single half sine-wave superimposed on rated load (JEDEC Method) per leg	I <sub>FSM</sub>	175		A
Peak repetitive reverse surge current per leg at t <sub>p</sub> = 2.0μs, 1KHz	I <sub>RRM</sub>	1.0		A
Operating junction and storage temperature range	T <sub>J</sub> , T <sub>STG</sub>	-40 to +125		°C
RMS Isolation voltage (SBLF type only) from terminals to heatsink with t = 1.0 second, RH ≤ 30%	V <sub>ISOL</sub>	4500 (NOTE 1) 3500 (NOTE 2) 1500 (NOTE 3)		V

## Electrical Characteristics (T<sub>C</sub> = 25°C unless otherwise noted)

Parameter	Symbol	Value	Unit
Maximum instantaneous forward voltage per leg at 10 A (Note 4)	V <sub>F</sub>	0.60	V
Maximum instantaneous current at rated DC blocking voltage per leg (Note 4)	I <sub>R</sub>	1.0 50	mA

## Thermal Characteristics (T<sub>C</sub> = 25°C unless otherwise noted)

Parameter	Symbol	SBL	SBLF	SBLB	Unit
Typical thermal resistance from junction to case per leg	R <sub>θJC</sub>	2.0	4.0	2.0	°C/W

### Notes:

- (1) Clip mounting (on case), where lead does not overlap heatsink with 0.110" offset
- (2) Clip mounting (on case), where leads do overlap heatsink
- (3) Screw mounting with 4-40 screw, where washer diameter is ≤ 4.9 mm (0.19")
- (4) Pulse test: 300μs pulse width, 1% duty cycle



## Ratings and Characteristic Curves ( $T_A = 25^\circ\text{C}$ unless otherwise noted)

### Forward Current Derating Curve

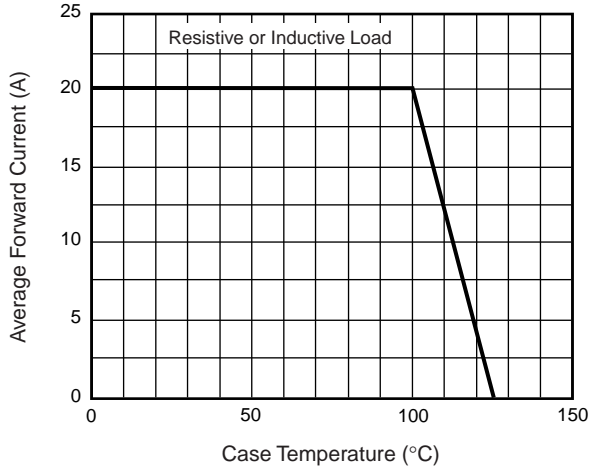

### Maximum Non-Repetitive Peak Forward Surge Current Per Leg

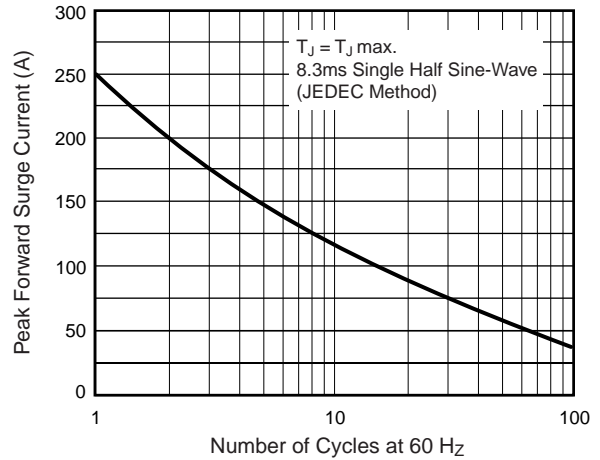

### Typical Instantaneous Forward Characteristics per Leg

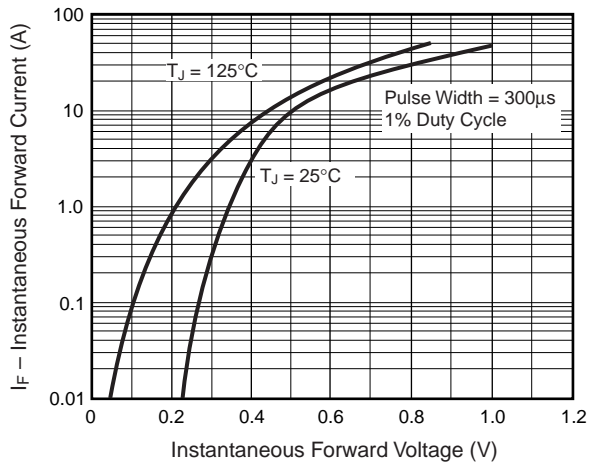

### Typical Reverse Characteristics Per Leg

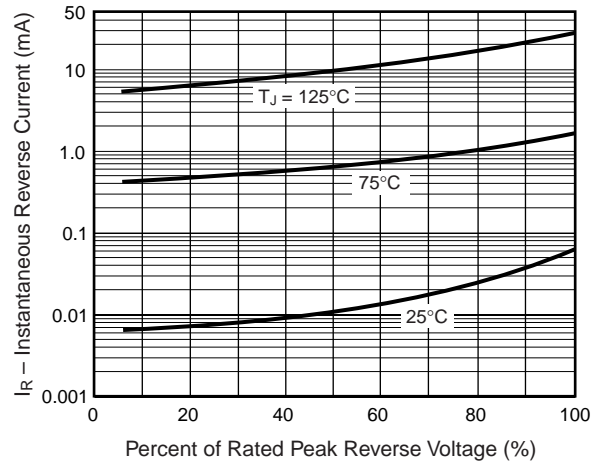

### Typical Junction Capacitance Per Leg

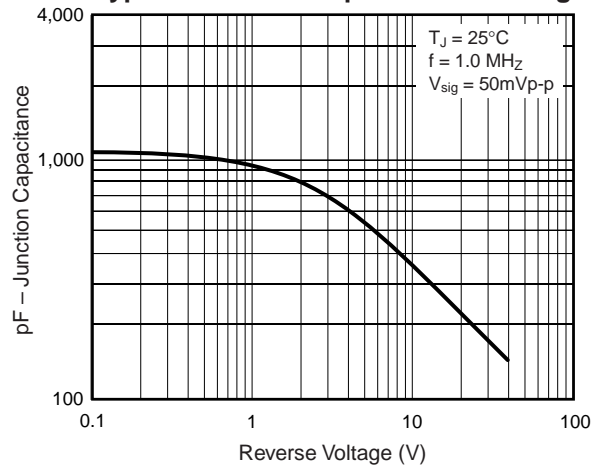

### Typical Transient Thermal Impedance Per Leg

