

SN74F543 OCTAL REGISTERED TRANSCEIVER WITH 3-STATE OUTPUTS

SDFS025B – D2942, MARCH 1987 – REVISED OCTOBER 1993

- 3-State True Outputs
- Back-to-Back Registers for Storage
- Package Options Include Plastic Small-Outline and Shrink Small-Outline Packages and Standard Plastic 300-mil DIPs

description

The SN74F543 octal transceiver contains two sets of D-type latches for temporary storage of data flowing in either direction. Separate latch-enable (\overline{LEAB} or \overline{LEBA}) and output enable (\overline{OEAB} or \overline{OEBA}) inputs are provided for each register to permit independent control in either direction of data flow. The A outputs are characterized to sink 24 mA while the B outputs are characterized to sink 64 mA.

The A-to-B enable (\overline{CEAB}) input must be low in order to enter data from A or to output data from B. Having \overline{CEAB} low and \overline{LEAB} low makes the A-to-B latches transparent; a subsequent low-to-high transition of \overline{LEAB} puts the A latches in the storage mode. With \overline{CEAB} and \overline{OEAB} both low, the 3-state B outputs are active and reflect the data present at the output of the A latches. Data flow from B to A is similar, but requires using the \overline{CEBA} , \overline{LEBA} , and \overline{OEBA} inputs.

The SN74F543 is available in TI's shrink small-outline package (DB), which provides the same I/O pin count and functionality of standard small-outline packages in less than half the printed-circuit-board area.

The SN74F543 is characterized for operation from 0°C to 70°C.

DB, DW, OR NT PACKAGE
(TOP VIEW)

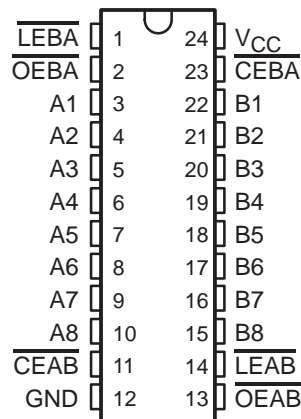

FUNCTION TABLE†

INPUTS				OUTPUT
\overline{CEAB}	\overline{LEAB}	\overline{OEAB}	A	B
H	X	X	X	Z
X	X	H	X	Z
L	H	L	X	B_0^\ddagger
L	L	L	L	L
L	L	L	H	H

† A-to-B data flow is shown; B-to-A flow control is the same except that it uses \overline{CEBA} , \overline{LEBA} , and \overline{OEBA} .

‡ Output level before the indicated steady-state input conditions were established.

SN74F543 OCTAL REGISTERED TRANSCIEVER WITH 3-STATE OUTPUTS

SDFS025B – D2942, MARCH 1987 – REVISED OCTOBER 1993

logic symbol†

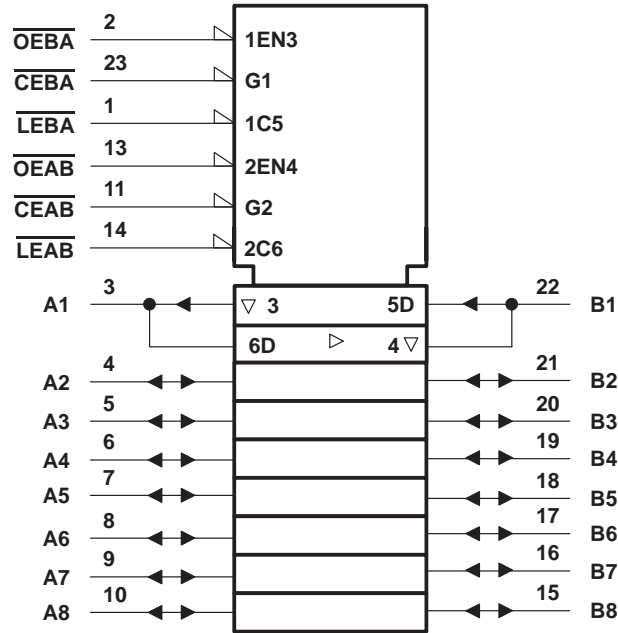

† This symbol is in accordance with ANSI/IEEE Std 91-1984 and IEC Publication 617-12.

logic diagram (positive logic)

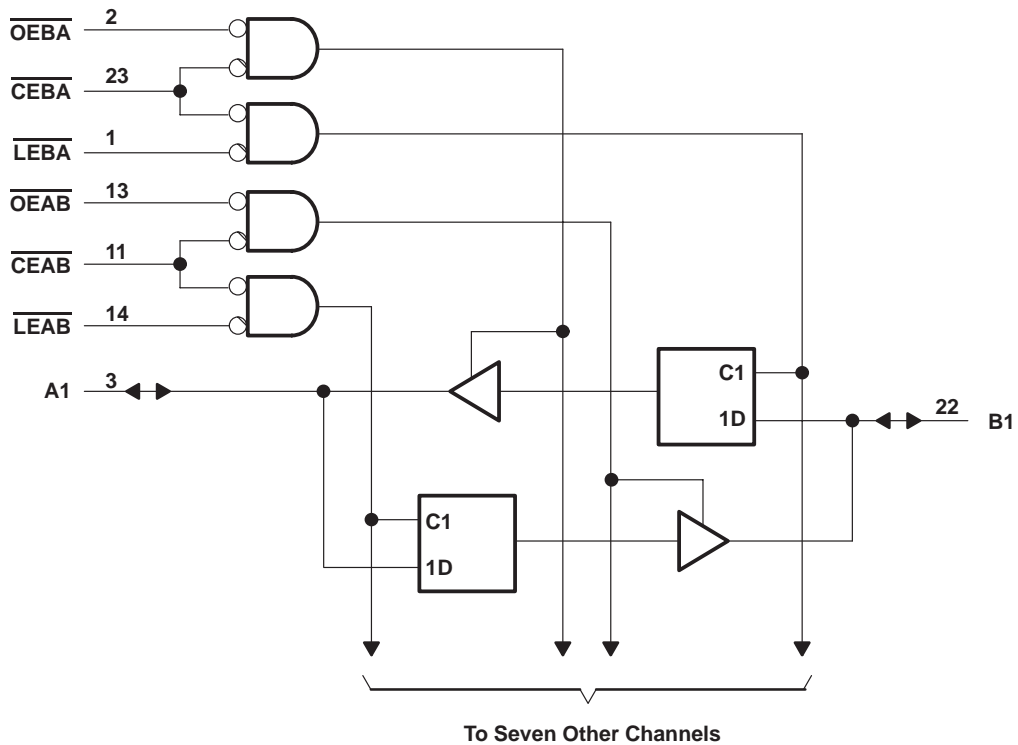

SN74F543
OCTAL REGISTERED TRANSCEIVER
WITH 3-STATE OUTPUTS

SDFS025B – D2942, MARCH 1987 – REVISED OCTOBER 1993

absolute maximum ratings over operating free-air temperature range (unless otherwise noted)†

Supply voltage range, V_{CC}	–0.5 V to 7 V
Input voltage range, V_I (excluding I/O ports) (see Note 1)	–1.2 V to 7 V
Input current range, I_{IK}	–30 mA to 5 mA
Voltage range applied to any output in the disabled or power-off state	–0.5 V to 5.5 V
Voltage range applied to any output in the high state	–0.5 V to V_{CC}
Current into any output in the low state: A1–A8	48 mA
B1–B8	128 mA
Operating free-air temperature range	0°C to 70°C
Storage temperature range	–65°C to 150°C

† Stresses beyond those listed under “absolute maximum ratings” may cause permanent damage to the device. These are stress ratings only, and functional operation of the device at these or any other conditions beyond those indicated under “recommended operating conditions” is not implied. Exposure to absolute-maximum-rated conditions for extended periods may affect device reliability.

NOTE 1: The input-voltage ratings may be exceeded provided the input-current ratings are observed.

recommended operating conditions

		MIN	NOM	MAX	UNIT
V_{CC}	Supply voltage	4.5	5	5.5	V
V_{IH}	High-level input voltage	2			V
V_{IL}	Low-level input voltage			0.8	V
I_{IK}	Input clamp current			–18	mA
I_{OH}	High-level output current	A1–A8		–3	mA
		B1–B8		–15	
I_{OL}	Low-level output current	A1–A8		24	mA
		B1–B8		64	
T_A	Operating free-air temperature	0		70	°C



SN74F543

OCTAL REGISTERED TRANSCEIVER WITH 3-STATE OUTPUTS

SDFS025B – D2942, MARCH 1987 – REVISED OCTOBER 1993

electrical characteristics over recommended operating free-air temperature range (unless otherwise noted)

PARAMETER		TEST CONDITIONS		MIN	TYP†	MAX	UNIT
V_{IK}		$V_{CC} = 4.5\text{ V}$,	$I_I = -18\text{ mA}$			-1.2	V
V_{OH}	A1–A8	$V_{CC} = 4.5\text{ V}$	$I_{OH} = -1\text{ mA}$	2.5	3.4		V
			$I_{OH} = -3\text{ mA}$	2.4	3.3		
	B1–B8		$I_{OH} = -3\text{ mA}$	2.4	3.3		
			$I_{OH} = -15\text{ mA}$	2	3.1		
Any output		$V_{CC} = 4.75\text{ V}$,	$I_{OH} = -1\text{ mA to } -3\text{ mA}$	2.7			
V_{OL}	A1–A8	$V_{CC} = 4.5\text{ V}$	$I_{OL} = 24\text{ mA}$		0.3	0.5	V
	B1–B8		$I_{OL} = 64\text{ mA}$		0.42	0.55	
I_I	\overline{OE} , \overline{LE} , and \overline{CE}	$V_{CC} = 5.5\text{ V}$	$V_I = 7\text{ V}$			0.1	mA
	A and B ports		$V_I = 5.5\text{ V}$			1	
$I_{IH}‡$	\overline{OE} , \overline{LE} , and \overline{CE}	$V_{CC} = 5.5\text{ V}$,	$V_I = 2.7\text{ V}$			20	μA
	A and B ports					70	
$I_{IL}‡$	\overline{OE} , \overline{LE} , and \overline{CE}	$V_{CC} = 5.5\text{ V}$,	$V_I = 0.5\text{ V}$			-1.2	mA
	A and B ports					-0.65	
$I_{OS}§$	A1–A8	$V_{CC} = 5.5\text{ V}$,	$V_O = 0$			-60	mA
	B1–B8					-100	
I_{CCH}		$V_{CC} = 5.5\text{ V}$			67	100	mA
I_{CCL}		$V_{CC} = 5.5\text{ V}$			83	125	mA
I_{CCZ}		$V_{CC} = 5.5\text{ V}$			83	125	mA

† All typical values are at $V_{CC} = 5\text{ V}$, $T_A = 25^\circ\text{C}$.

‡ For I/O ports, the parameters I_{IH} and I_{IL} include the off-state output current.

§ Not more than one output should be shorted at a time, and the duration of the short circuit should not exceed one second.

timing requirements

		$V_{CC} = 5\text{ V}$, $T_A = 25^\circ\text{C}$		$V_{CC} = 4.5\text{ V to } 5.5\text{ V}$, $T_A = \text{MIN to MAX}¶$		UNIT
		MIN	MAX	MIN	MAX	
t_w	Pulse duration	5		5		ns
t_{su}	Setup time, data before latch enable		High or low	3	3.5	ns
t_h	Hold time, data after latch enable		High or low	3	3.5	ns

¶ For conditions shown as MIN or MAX, use the appropriate value specified under recommended operating conditions.

SN74F543
OCTAL REGISTERED TRANSCEIVER
WITH 3-STATE OUTPUTS

SDFS025B – D2942, MARCH 1987 – REVISED OCTOBER 1993

switching characteristics (see Note 2)

PARAMETER	FROM (INPUT)	TO (OUTPUT)	V _{CC} = 5 V, C _L = 50 pF, R _L = 500 Ω, T _A = 25°C			V _{CC} = 4.5 V to 5.5 V, C _L = 50 pF, R _L = 500 Ω, T _A = MIN to MAX†		UNIT
			MIN	TYP	MAX	MIN	MAX	
t _{PLH}	A or B	B or A	2.2	5.1	7.5	2.2	8.5	ns
t _{PHL}			2.2	4.6	6.5	2.2	7.5	
t _{PLH}	\overline{LEBA}	A	3.7	8.1	11	4.1	12.5	ns
t _{PHL}			3.7	8.1	11	4.1	12.5	
t _{PLH}	\overline{LEAB}	B	3.7	8.1	11	4.1	12.5	ns
t _{PHL}			3.7	8.1	11	4.1	12.5	
t _{PZH}	\overline{OE} or \overline{CE}	A or B	2.2	6.6	9	2.2	10	ns
t _{PZL}			3.2	7.1	10.5	3.2	12	
t _{PHZ}	\overline{OE} or \overline{CE}	A or B	1.7	5.6	8	1.7	9	ns
t _{PLZ}			1.7	5.1	7.5	1.7	8.5	

† For conditions shown as MIN or MAX, use the appropriate value specified under recommended operating conditions.

NOTE 2: Load circuits and waveforms are shown in Section 1.

IMPORTANT NOTICE

Texas Instruments and its subsidiaries (TI) reserve the right to make changes to their products or to discontinue any product or service without notice, and advise customers to obtain the latest version of relevant information to verify, before placing orders, that information being relied on is current and complete. All products are sold subject to the terms and conditions of sale supplied at the time of order acknowledgement, including those pertaining to warranty, patent infringement, and limitation of liability.

TI warrants performance of its semiconductor products to the specifications applicable at the time of sale in accordance with TI's standard warranty. Testing and other quality control techniques are utilized to the extent TI deems necessary to support this warranty. Specific testing of all parameters of each device is not necessarily performed, except those mandated by government requirements.

CERTAIN APPLICATIONS USING SEMICONDUCTOR PRODUCTS MAY INVOLVE POTENTIAL RISKS OF DEATH, PERSONAL INJURY, OR SEVERE PROPERTY OR ENVIRONMENTAL DAMAGE ("CRITICAL APPLICATIONS"). TI SEMICONDUCTOR PRODUCTS ARE NOT DESIGNED, AUTHORIZED, OR WARRANTED TO BE SUITABLE FOR USE IN LIFE-SUPPORT DEVICES OR SYSTEMS OR OTHER CRITICAL APPLICATIONS. INCLUSION OF TI PRODUCTS IN SUCH APPLICATIONS IS UNDERSTOOD TO BE FULLY AT THE CUSTOMER'S RISK.

In order to minimize risks associated with the customer's applications, adequate design and operating safeguards must be provided by the customer to minimize inherent or procedural hazards.

TI assumes no liability for applications assistance or customer product design. TI does not warrant or represent that any license, either express or implied, is granted under any patent right, copyright, mask work right, or other intellectual property right of TI covering or relating to any combination, machine, or process in which such semiconductor products or services might be or are used. TI's publication of information regarding any third party's products or services does not constitute TI's approval, warranty or endorsement thereof.