

NLASB3157

2:1 Multiplexer

The NLASB3157 is an advanced CMOS analog switch fabricated with silicon gate CMOS technology. It achieves very low propagation delay and $R_{DS(ON)}$ resistances while maintaining CMOS low power dissipation. Analog and digital voltages that may vary across the full power-supply range (from V_{CC} to GND). This device is a drop in replacement for the NC7SB3157.

The select pin has overvoltage protection that allows voltages above V_{CC} , up to 7.0 V to be present on the pin without damage or disruption of operation of the part, regardless of the operating voltage.

Features

- High Speed: $t_{PD} = 1.0$ ns (Typ) at $V_{CC} = 5.0$ V
- Low Power Dissipation: $I_{CC} = 2.0$ μ A (Max) at $T_A = 25^\circ$ C
- Standard CMOS Logic Levels
- High Bandwidth, Improved Linearity
- Switches Standard NTSC/PAL Video, Audio, SPDIF and HDTV
- May be used for Clock Switching, Data Mux'ing, etc.
- Low $R_{DS(ON)}$
- Break Before Make Circuitry, Prevents Inadvertent Shorts
- 2 Devices can Switch Balanced Signal Pairs, e.g. LVDS > 200-Mb/s
- Latchup Performance Exceeds 300 mA
- Pin for Pin Drop in for NC7SB3157
- Tiny SC88 Package Only 2.0 x 2.1 mm
- ESD Performance: Human Body Model; > 2000 V; Machine Model; > 200 V
- Extended Automotive Temperature Range -55° C to $+125^\circ$ C (See Appendix)
- Pb-Free Package is Available

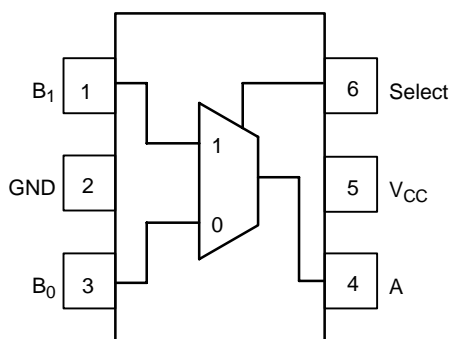

Figure 1. Pinout (Top View)



ON Semiconductor®

<http://onsemi.com>



SC-88
DF SUFFIX
CASE 419B

MARKING DIAGRAM

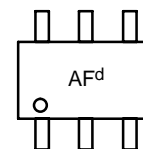

AF = Specific Device Code
d = Date Code

ORDERING INFORMATION

| Device | Package | Shipping† |
|----------------|-------------------|------------------|
| NLASB3157DFT2 | SC88 | 3000 Tape & Reel |
| NLASB3157DFT2G | SC88 (Pb-Free) | 3000 Tape & Reel |

†For information on tape and reel specifications, including part orientation and tape sizes, please refer to our Tape and Reel Packaging Specifications Brochure, BRD8011/D.

FUNCTION TABLE

| Select Input | Function |
|--------------|-------------------|
| L | B0 Connected to A |
| H | B1 Connected to A |

NLASB3157

MAXIMUM RATINGS

| Rating | Symbol | Value | Unit |
|---|------------------|------------------------|------|
| Supply Voltage | V_{CC} | -0.5 to +7.0 | V |
| DC Switch Voltage (Note 1) | V_S | -0.5 to $V_{CC} + 0.5$ | V |
| DC Input Voltage (Note 1) | V_{IN} | -0.5 to + 7.0 | V |
| DC Input Diode Current @ $V_{IN} < 0$ V | I_{IK} | -50 | mA |
| DC Output Current | I_{OUT} | 128 | mA |
| DC V_{CC} or Ground Current | I_{CC}/I_{GND} | +100 | mA |
| Storage Temperature Range | T_{stg} | -65 to +150 | °C |
| Junction Temperature Under Bias | T_J | 150 | °C |
| Junction Lead Temperature (Soldering, 10 Seconds) | T_L | 260 | °C |
| Power Dissipation @ +85°C | P_D | 180 | mW |

Maximum ratings are DC values beyond which the device may be damaged or have its useful life impaired. The data sheet specifications should be met, without exception, to ensure that the system design is reliable over its power supply, temperature, and output/input loading variables. ON Semiconductor does not recommend operation outside data sheet specifications.

1. The input and output negative voltage ratings may be exceeded if the input and output diode current ratings are observed.

RECOMMENDED OPERATING CONDITIONS (Note 2)

| Characteristic | Symbol | Min | Max | Unit |
|--|---------------|--------|-----------|------|
| Supply Voltage Operating | V_{CC} | 1.65 | 5.5 | V |
| Select Input Voltage | V_{IN} | 0 | V_{CC} | V |
| Switch Input Voltage | V_{IN} | 0 | V_{CC} | V |
| Output Voltage | V_{OUT} | 0 | V_{CC} | V |
| Operating Temperature | T_A | -55 | +125 | °C |
| Input Rise and Fall Time Control Input $V_{CC} = 2.3$ V–3.6 V Control Input $V_{CC} = 4.5$ V–5.5 V | t_r, t_f | 0 0 | 10 5.0 | ns/V |
| Thermal Resistance | θ_{JA} | - | 350 | °C/W |

2. Select input must be held HIGH or LOW, it must not float.

NLASB3157

DC ELECTRICAL CHARACTERISTICS

| Symbol | Parameter | Test Conditions | V _{CC} (V) | T _A = +25°C | | | T _A = -40°C to +85°C | | Unit |
|--------------------|---|--|------------------------|------------------------|-------|-----------------|---|---|------|
| | | | | Min | Typ | Max | Min | Max | |
| V _{IH} | HIGH Level Input Voltage | | 1.65–1.95 2.3–5.5 | | | | 0.75 V _{CC} 0.7 V _{CC} | | V |
| V _{IL} | LOW Level Input Voltage | | 1.65–1.95 2.3–5.5 | | | | | 0.25 V _{CC} 0.3 V _{CC} | V |
| I _{IN} | Input Leakage Current | 0 ≤ V _{IN} ≤ 5.5 V | 0–5.5 | | ±0.05 | ±0.1 | | ±1 | μA |
| I _{OFF} | OFF State Leakage Current | 0 ≤ A, B ≤ V _{CC} | 1.65–5.5 | | ±0.05 | ±0.1 | | ±1 | μA |
| R _{ON} | Switch On Resistance (Note 3) | V _{IN} = 0 V, I _O = 30 mA | 4.5 | | 3.0 | | | 7.0 | Ω |
| | | V _{IN} = 2.4 V, I _O = -30 mA | | | 5.0 | | | 12 | |
| | | V _{IN} = 4.5 V, I _O = -30 mA | | | 7.0 | | | 15 | |
| | | V _{IN} = 0 V, I _O = 24 mA | 3.0 | | 4.0 | | | 9.0 | |
| | | V _{IN} = 3 V, I _O = -24 mA | | | 10 | | | 20 | Ω |
| | | V _{IN} = 0 V, I _O = 8 mA | 2.3 | | 5.0 | | | 12 | Ω |
| | | V _{IN} = 2.3 V, I _O = -8 mA | | | 13 | | | 30 | |
| | | V _{IN} = 0 V, I _O = 4 mA | 1.65 | | 6.5 | | | 20 | Ω |
| | | V _{IN} = 1.65 V, I _O = -4 mA | | | 17 | | | 50 | |
| I _{CC} | Quiescent Supply Current All Channels ON or OFF | V _{IN} = V _{CC} or GND I _{OUT} = 0 | 5.5 | | | 1.0 | | 10 | μA |
| | Analog Signal Range | | V _{CC} | 0 | | V _{CC} | 0 | V _{CC} | V |
| R _{RANGE} | On Resistance Over Signal Range (Note 3) (Note 7) | I _A = -30 mA, 0 ≤ V _{Bn} ≤ V _{CC} | 4.5 | | | | | 25 | Ω |
| | | I _A = -24 mA, 0 ≤ V _{Bn} ≤ V _{CC} | 3.0 | | | | | 50 | |
| | | I _A = -8 mA, 0 ≤ V _{Bn} ≤ V _{CC} | 2.3 | | | | | 100 | |
| | | I _A = -4 mA, 0 ≤ V _{Bn} ≤ V _{CC} | 1.65 | | | | | 300 | |
| ΔR _{ON} | On Resistance Match Between Channels (Note 3) (Note 4) (Note 5) | I _A = -30 mA, V _{Bn} = 3.15 | 4.5 | | 0.15 | | | | Ω |
| | | I _A = -24 mA, V _{Bn} = 2.1 | 3.0 | | 0.2 | | | | |
| | | I _A = -8 mA, V _{Bn} = 1.6 | 2.3 | | 0.5 | | | | |
| | | I _A = -4 mA, V _{Bn} = 1.15 | 1.65 | | 0.5 | | | | |
| R _{flat} | On Resistance Flatness (Note 3) (Note 4) (Note 6) | I _A = -30 mA, 0 ≤ V _{Bn} ≤ V _{CC} | 5.0 | | 6.0 | | | | Ω |
| | | I _A = -24 mA, 0 ≤ V _{Bn} ≤ V _{CC} | 3.3 | | 12 | | | | |
| | | I _A = -8 mA, 0 ≤ V _{Bn} ≤ V _{CC} | 2.5 | | 28 | | | | |
| | | I _A = -4 mA, 0 ≤ V _{Bn} ≤ V _{CC} | 1.8 | | 125 | | | | |

3. Measured by the voltage drop between A and B pins at the indicated current through the switch. On Resistance is determined by the lower of the voltages on the two (A or B Ports).

4. Parameter is characterized but not tested in production.

5. ΔR_{ON} = R_{ON} max – R_{ON} min measured at identical V_{CC}, temperature and voltage levels.

6. Flatness is defined as the difference between the maximum and minimum value of On Resistance over the specified range of conditions.

7. Guaranteed by Design.

NLASB3157

AC ELECTRICAL CHARACTERISTICS

| Symbol | Parameter | Test Conditions | V _{CC} (V) | T _A = +25°C | | | T _A = -40°C to +85°C | | Unit | Figure Number |
|--------------------------------------|--|--|--|------------------------|------------|---------------------------|---------------------------------|-------------------------|------|-----------------|
| | | | | Min | Typ | Max | Min | Max | | |
| t _{PHL} t _{PLH} | Propagation Delay Bus to Bus (Note 9) | V _I = OPEN | 1.65–1.95 2.3–2.7 3.0–3.6 4.5–5.5 | | | | | 1.2 0.8 0.3 | ns | Figures 2, 3 |
| t _{PZL} t _{PZH} | Output Enable Time Turn On Time (A to B _n) | V _I = 2 × V _{CC} for t _{PZL} V _I = 0 V for t _{PZH} | 1.65–1.95 2.3–2.7 3.0–3.6 4.5–5.5 | | | 23 13 6.9 5.2 | 7.0 3.5 2.5 1.7 | 24 14 7.6 5.7 | ns | Figures 2, 3 |
| t _{PLZ} t _{PHZ} | Output Disable Time Turn Off Time (A Port to B Port) | V _I = 2 × V _{CC} for t _{PLZ} V _I = 0 V for t _{PHZ} | 1.65–1.95 2.3–2.7 3.0–3.6 4.5–5.5 | | | 12.5 7.0 5.0 3.5 | 3.0 2.0 1.5 0.8 | 13 7.5 5.3 3.8 | ns | Figures 2, 3 |
| t _{B-M} | Break Before Make Time (Note 8) | | 1.65–1.95 2.3–2.7 3.0–3.6 4.5–5.5 | | | | 0.5 0.5 0.5 0.5 | | ns | Figure 4 |
| Q | Charge Injection (Note 8) | C _L = 0.1 nF, V _{GEN} = 0 V R _{GEN} = 0 Ω | 5.0 3.3 | | 7.0 3.0 | | | | pC | Figure 5 |
| OIRR | Off Isolation (Note 10) | R _L = 50 Ω f = 10 MHz | 1.65–5.5 | | -57 | | | | dB | Figure 6 |
| Xtalk | Crosstalk | R _L = 50 Ω f = 10 MHz | 1.65–5.5 | | -54 | | | | dB | Figure 7 |
| BW | -3 dB Bandwidth | R _L = 50 Ω | 1.65–5.5 | | 250 | | | | MHz | Figure 10 |
| THD | Total Harmonic Distortion (Note 8) | R _L = 600 Ω 0.5 V _{P-P} f = 600 Hz to 20 kHz | 5.0 | | 0.011 | | | | % | |

CAPACITANCE (Note 11)

| Symbol | Parameter | Test Conditions | Typ | Max | Unit | Figure Number |
|---------------------|---|-------------------------|------|-----|------|---------------|
| C _{IN} | Select Pin Input Capacitance | V _{CC} = 0 V | 2.3 | | pF | |
| C _{IO-B} | B Port Off Capacitance | V _{CC} = 5.0 V | 6.5 | | pF | Figure 8 |
| C _{IOA-ON} | A Port Capacitance when Switch is Enabled | V _{CC} = 5.0 V | 18.5 | | pF | Figure 9 |

8. Guaranteed by Design.

9. This parameter is guaranteed by design but not tested. The bus switch contributes no propagation delay other than the RC delay of the On Resistance of the switch and the 50 pF load capacitance, when driven by an ideal voltage source (zero output impedance).

10. Off Isolation = 20 log₁₀ [V_A/V_{Bn}].

11. T_A = +25°C, f = 1 MHz, Capacitance is characterized but not tested in production.

APPENDIX A

DC ELECTRICAL EXTENDED AUTOMOTIVE TEMPERATURE RANGE CHARACTERISTICS

| Symbol | Parameter | Test Conditions | V _{CC} (V) | T _A = +25°C | | | T _A = -55°C to +125°C | | Unit |
|--------------------|---|---|------------------------|------------------------|-------------------|-----------------|---|---|------|
| | | | | Min | Typ | Max | Min | Max | |
| V _{IH} | HIGH Level Input Voltage | | 1.65–1.95 2.3–5.5 | | | | 0.75 V _{CC} 0.7 V _{CC} | | V |
| V _{IL} | LOW Level Input Voltage | | 1.65–1.95 2.3–5.5 | | | | | 0.25 V _{CC} 0.3 V _{CC} | V |
| I _{IN} | Input Leakage Current | 0 ≤ V _{IN} ≤ 5.5 V | 0–5.5 | | ±0.05 | ±0.1 | | ±1 | μA |
| I _{OFF} | OFF State Leakage Current | 0 ≤ A, B ≤ V _{CC} | 1.65–5.5 | | ±0.05 | ±0.1 | | ±1 | μA |
| R _{ON} | Switch On Resistance (Note 12) | V _{IN} = 0 V, I _O = 30 mA V _{IN} = 2.4 V, I _O = -30 mA V _{IN} = 4.5 V, I _O = -30 mA | 4.5 | | 3.0 5.0 7.0 | | | 8.5 13.0 15.0 | Ω |
| | | V _{IN} = 0 V, I _O = 24 mA V _{IN} = 3 V, I _O = -24 mA | 3.0 | | 4.0 10 | | | 11 20 | |
| | | V _{IN} = 0 V, I _O = 8 mA V _{IN} = 2.3 V, I _O = -8 mA | 2.3 | | 5.0 13 | | | 12 30 | |
| | | V _{IN} = 0 V, I _O = 4 mA V _{IN} = 1.65 V, I _O = -4 mA | 1.65 | | 6.5 17 | | | 20 50 | |
| I _{CC} | Quiescent Supply Current All Channels ON or OFF | V _{IN} = V _{CC} or GND I _{OUT} = 0 | 5.5 | | | 1.0 | | 10 | μA |
| | Analog Signal Range | | V _{CC} | 0 | | V _{CC} | 0 | V _{CC} | V |
| R _{RANGE} | On Resistance Over Signal Range (Note 12) (Note 14) | I _A = -30 mA, 0 ≤ V _{Bn} ≤ V _{CC} | 4.5 | | | | | 25 | Ω |
| | | I _A = -24 mA, 0 ≤ V _{Bn} ≤ V _{CC} | 3.0 | | | | | 50 | |
| | | I _A = -8 mA, 0 ≤ V _{Bn} ≤ V _{CC} | 2.3 | | | | | 100 | |
| | | I _A = -4 mA, 0 ≤ V _{Bn} ≤ V _{CC} | 1.65 | | | | | 300 | |

12. Measured by the voltage drop between A and B pins at the indicated current through the switch. On Resistance is determined by the lower of the voltages on the two (A or B Ports).

13. Flatness is defined as the difference between the maximum and minimum value of On Resistance over the specified range of conditions.

14. Guaranteed by Design.

* For ΔR_{ON}, R_{FLAT}, Q, OIRR, Xtalk, BW, THD, and CIN see -40°C to 85°C section.

NLASB3157

APPENDIX A

AC ELECTRICAL EXTENDED AUTOMOTIVE TEMPERATURE RANGE CHARACTERISTICS

| Symbol | Parameter | Test Conditions | V _{CC} (V) | T _A = +25°C | | | T _A = -55°C to +125°C | | Unit | Figure Number |
|--------------------------------------|--|--|--|------------------------|-----|---------------------------|----------------------------------|-------------------------|------|-----------------|
| | | | | Min | Typ | Max | Min | Max | | |
| t _{PHL} t _{PLH} | Propagation Delay Bus to Bus (Note 16) | V _I = OPEN | 1.65–1.95 2.3–2.7 3.0–3.6 4.5–5.5 | | | | | 1.2 0.8 0.3 | ns | Figures 2, 3 |
| t _{PZL} t _{PZH} | Output Enable Time Turn On Time (A to B _n) | V _I = 2 × V _{CC} for t _{PZL} V _I = 0 V for t _{PZH} | 1.65–1.95 2.3–2.7 3.0–3.6 4.5–5.5 | | | 23 13 6.9 5.2 | 7.0 3.5 2.5 1.7 | 24 14 9.0 7.0 | ns | Figures 2, 3 |
| t _{PLZ} t _{PHZ} | Output Disable Time Turn Off Time (A Port to B Port) | V _I = 2 × V _{CC} for t _{PLZ} V _I = 0 V for t _{PHZ} | 1.65–1.95 2.3–2.7 3.0–3.6 4.5–5.5 | | | 12.5 7.0 5.0 3.5 | 3.0 2.0 1.5 0.8 | 13 7.5 6.5 5.0 | ns | Figures 2, 3 |
| t _{B-M} | Break Before Make Time (Note 15) | | 1.65–1.95 2.3–2.7 3.0–3.6 4.5–5.5 | | | | 0.5 0.5 0.5 0.5 | | ns | Figure 4 |

15. Guaranteed by Design.

16. This parameter is guaranteed by design but not tested. The bus switch contributes no propagation delay other than the RC delay of the On Resistance of the switch and the 50 pF load capacitance, when driven by an ideal voltage source (zero output impedance).

* For ΔR_{ON} , R_{FLAT} , Q, OIRR, Xtalk, BW, THD, and CIN see -40°C to 85°C section.

NLASB3157

AC LOADING AND WAVEFORMS

NOTE: Input driven by 50 Ω source terminated in 50 Ω
 NOTE: C_L includes load and stray capacitance
 NOTE: Input PRR = 1.0 MHz; $t_W = 500$ ns

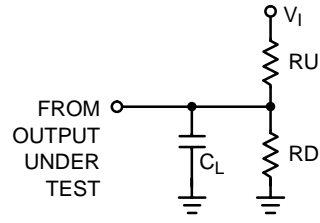

Figure 2. AC Test Circuit

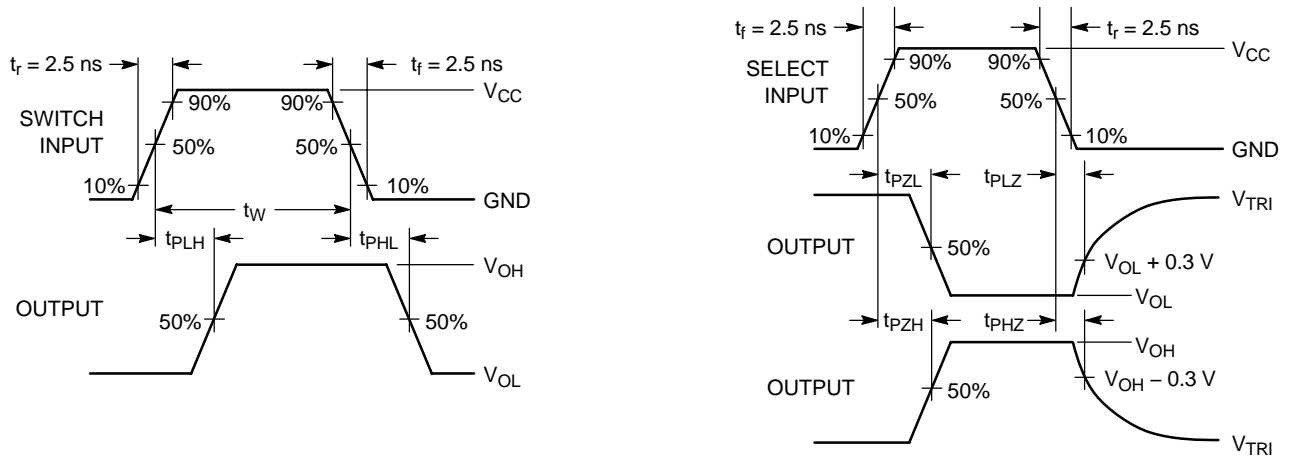

Figure 3. AC Waveforms



Figure 4. Break Before Make Interval Timing

AC LOADING AND WAVEFORMS

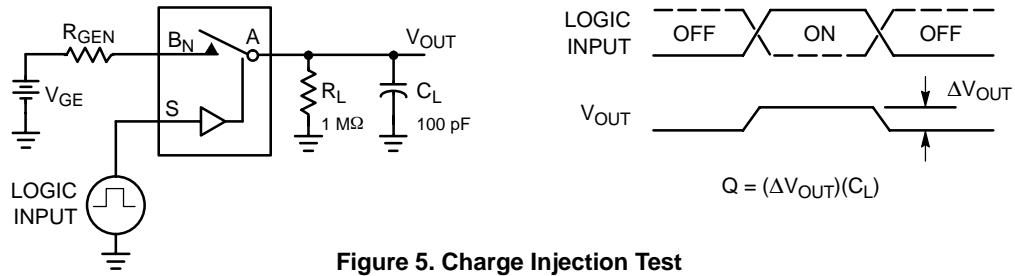

Figure 5. Charge Injection Test

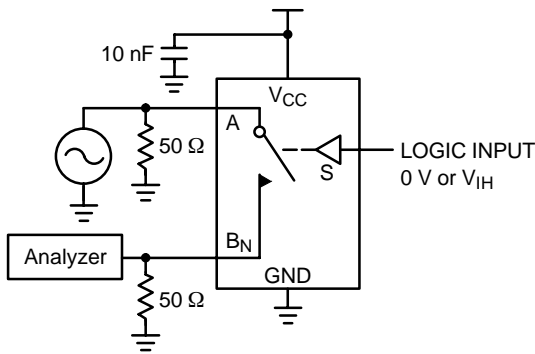

Figure 6. Off Isolation

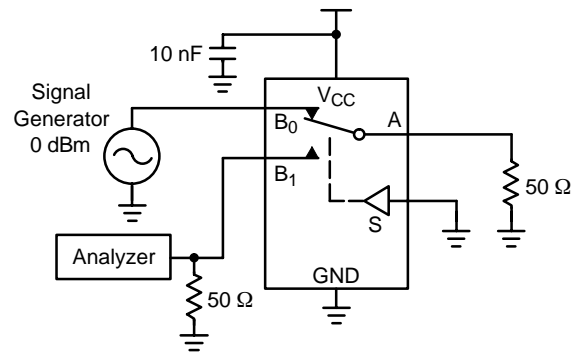

Figure 7. Crosstalk

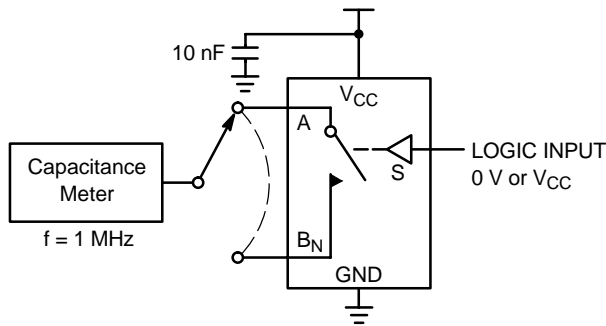

Figure 8. Channel Off Capacitance

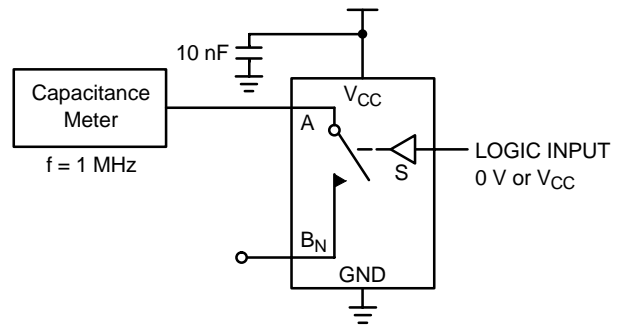

Figure 9. Channel On Capacitance

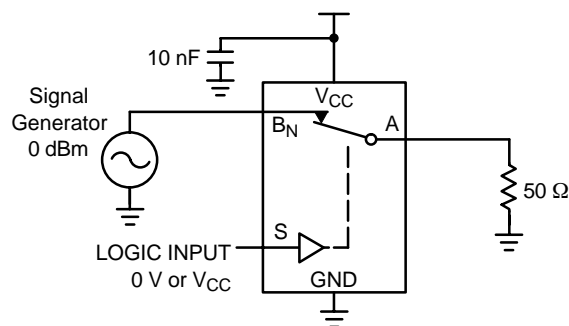
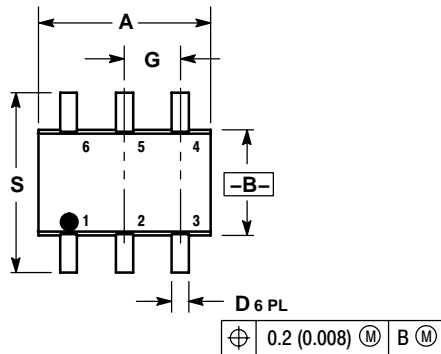

Figure 10. Bandwidth

NLASB3157

PACKAGE DIMENSIONS

SC-88/SOT-363/SC-70
 DF SUFFIX
 CASE 419B-02
 ISSUE U



- NOTES:
 1. DIMENSIONING AND TOLERANCING PER ANSI Y14.5M, 1982.
 2. CONTROLLING DIMENSION: INCH.
 3. 419B-01 OBSOLETE, NEW STANDARD 419B-02.

| DIM | INCHES | | MILLIMETERS | |
|-----|-----------|-------|-------------|------|
| | MIN | MAX | MIN | MAX |
| A | 0.071 | 0.087 | 1.80 | 2.20 |
| B | 0.045 | 0.053 | 1.15 | 1.35 |
| C | 0.031 | 0.043 | 0.80 | 1.10 |
| D | 0.004 | 0.012 | 0.10 | 0.30 |
| G | 0.026 BSC | | 0.65 BSC | |
| H | --- | 0.004 | --- | 0.10 |
| J | 0.004 | 0.010 | 0.10 | 0.25 |
| K | 0.004 | 0.012 | 0.10 | 0.30 |
| N | 0.008 REF | | 0.20 REF | |
| S | 0.079 | 0.087 | 2.00 | 2.20 |

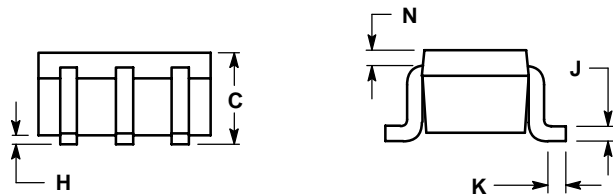

SOLDERING FOOTPRINT*

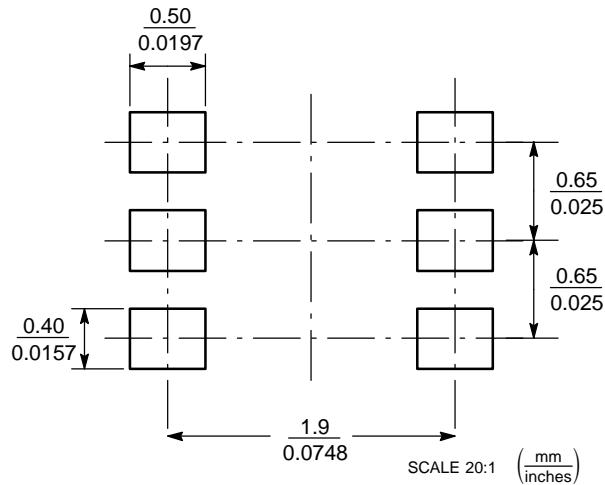

*For additional information on our Pb-Free strategy and soldering details, please download the ON Semiconductor Soldering and Mounting Techniques Reference Manual, SOLDERRM/D.

ON Semiconductor and  are registered trademarks of Semiconductor Components Industries, LLC (SCILLC). SCILLC reserves the right to make changes without further notice to any products herein. SCILLC makes no warranty, representation or guarantee regarding the suitability of its products for any particular purpose, nor does SCILLC assume any liability arising out of the application or use of any product or circuit, and specifically disclaims any and all liability, including without limitation special, consequential or incidental damages. "Typical" parameters which may be provided in SCILLC data sheets and/or specifications can and do vary in different applications and actual performance may vary over time. All operating parameters, including "Typicals" must be validated for each customer application by customer's technical experts. SCILLC does not convey any license under its patent rights nor the rights of others. SCILLC products are not designed, intended, or authorized for use as components in systems intended for surgical implant into the body, or other applications intended to support or sustain life, or for any other application in which the failure of the SCILLC product could create a situation where personal injury or death may occur. Should Buyer purchase or use SCILLC products for any such unintended or unauthorized application, Buyer shall indemnify and hold SCILLC and its officers, employees, subsidiaries, affiliates, and distributors harmless against all claims, costs, damages, and expenses, and reasonable attorney fees arising out of, directly or indirectly, any claim of personal injury or death associated with such unintended or unauthorized use, even if such claim alleges that SCILLC was negligent regarding the design or manufacture of the part. SCILLC is an Equal Opportunity/Affirmative Action Employer. This literature is subject to all applicable copyright laws and is not for resale in any manner.

PUBLICATION ORDERING INFORMATION

LITERATURE FULFILLMENT:

Literature Distribution Center for ON Semiconductor
P.O. Box 5163, Denver, Colorado 80217 USA

Phone: 303-675-2175 or 800-344-3860 Toll Free USA/Canada

Fax: 303-675-2176 or 800-344-3867 Toll Free USA/Canada

Email: orderlit@onsemi.com

N. American Technical Support: 800-282-9855 Toll Free
USA/Canada

Japan: ON Semiconductor, Japan Customer Focus Center
2-9-1 Kamimeguro, Meguro-ku, Tokyo, Japan 153-0051

Phone: 81-3-5773-3850

ON Semiconductor Website: <http://onsemi.com>

Order Literature: <http://www.onsemi.com/litorder>

For additional information, please contact your
local Sales Representative.