

- 1 - Cathode 1
- 2 - Anode
- 3 - Cathode 2
- Back of Case - Anode

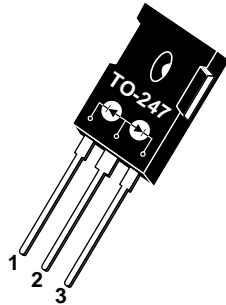

APT30D20BCA 200V 2x30A

ULTRAFAST SOFT RECOVERY RECTIFIER DIODES

PRODUCT APPLICATIONS	PRODUCT FEATURES	PRODUCT BENEFITS
<ul style="list-style-type: none"> • Parallel Diode <ul style="list-style-type: none"> -Switchmode Power Supply -Inverters • Free Wheeling Diode <ul style="list-style-type: none"> -Motor Controllers -Converters • Snubber Diode • Uninterruptible Power Supply (UPS) • Induction Heating • High Speed Rectifiers 	<ul style="list-style-type: none"> • Ultrafast Recovery Times • Soft Recovery Characteristics • Popular TO-247 Package • Low Forward Voltage • High Blocking Voltage • Low Leakage Current 	<ul style="list-style-type: none"> • Low Losses • Low Noise Switching • Cooler Operation • Higher Reliability Systems • Increased System Power Density

MAXIMUM RATINGS

All Ratings Are Per Leg: $T_C = 25^\circ\text{C}$ unless otherwise specified.

Symbol	Characteristic / Test Conditions	APT30D20BCA	UNIT
V_R	Maximum D.C. Reverse Voltage	200	Volts
V_{RRM}	Maximum Peak Repetitive Reverse Voltage		
V_{RWM}	Maximum Working Peak Reverse Voltage		
$I_F(AV)$	Maximum Average Forward Current ($T_C = 105^\circ\text{C}$, Duty Cycle = 0.5)	30	Amps
$I_F(RMS)$	RMS Forward Current	70	
I_{FSM}	Non-Repetitive Forward Surge Current ($T_J = 45^\circ\text{C}$, 8.3ms)	320	
T_J, T_{STG}	Operating and Storage Temperature Range	-55 to 150	$^\circ\text{C}$
T_L	Lead Temperature: 0.063" from Case for 10 Sec.	300	

STATIC ELECTRICAL CHARACTERISTICS

Symbol	Characteristic / Test Conditions	MIN	TYP	MAX	UNIT
V_F	Maximum Forward Voltage			1.15	Volts
				$I_F = 30\text{A}$	
				$I_F = 60\text{A}$	
I_{RM}	Maximum Reverse Leakage Current			1.0	μA
				$I_F = 30\text{A}, T_J = 150^\circ\text{C}$	
				$V_R = V_R$ Rated	
I_{RM}	Maximum Reverse Leakage Current			500	μA
				$V_R = V_R$ Rated, $T_J = 125^\circ\text{C}$	
C_T	Junction Capacitance, $V_R = 150\text{V}$		110		pF
L_S	Series Inductance (Lead to Lead 5mm from Base)		10		nH

APT Website - <http://www.advancedpower.com>

USA 405 S.W. Columbia Street Bend, Oregon 97702-1035 Phone: (541) 382-8028 FAX: (541) 388-0364
EUROPE Chemin de Magret F-33700 Merignac - France Phone: (33) 5 57 92 15 15 FAX: (33) 5 56 47 97 61

DYNAMIC CHARACTERISTICS

APT30D20BCA

Symbol	Characteristic	MIN	TYP	MAX	UNIT
t_{rr1}	Reverse Recovery Time, $I_F = 1.0A$, $di_F/dt = -15A/\mu s$, $V_R = 30V$, $T_J = 25^\circ C$		35	50	ns
t_{rr2}	Reverse Recovery Time	$T_J = 25^\circ C$	40		
t_{rr3}	$I_F = 30A$, $di_F/dt = -240A/\mu s$, $V_R = 100V$	$T_J = 100^\circ C$	60		
t_{fr1}	Forward Recovery Time	$T_J = 25^\circ C$	155		
t_{fr2}	$I_F = 30A$, $di_F/dt = 240A/\mu s$, $V_R = 100V$	$T_J = 100^\circ C$	155		
I_{RRM1}	Reverse Recovery Current	$T_J = 25^\circ C$	6	8	Amps
I_{RRM2}	$I_F = 30A$, $di_F/dt = -240A/\mu s$, $V_R = 100V$	$T_J = 100^\circ C$	10	13	
Q_{rr1}	Recovery Charge	$T_J = 25^\circ C$	120		nC
Q_{rr2}	$I_F = 30A$, $di_F/dt = -240A/\mu s$, $V_R = 100V$	$T_J = 100^\circ C$	300		
V_{fr1}	Forward Recovery Voltage	$T_J = 25^\circ C$	2.5		Volts
V_{fr2}	$I_F = 30A$, $di_F/dt = 240A/\mu s$, $V_R = 100V$	$T_J = 100^\circ C$	2.5		
diM/dt	Rate of Fall of Recovery Current	$T_J = 25^\circ C$	300		A/ μs
	$I_F = 30A$, $di_F/dt = -240A/\mu s$, $V_R = 100V$	$T_J = 100^\circ C$	600		

THERMAL AND MECHANICAL CHARACTERISTICS

Symbol	Characteristic / Test Conditions	MIN	TYP	MAX	UNIT
$R_{\theta JC}$	Junction-to-Case Thermal Resistance			1.32	$^\circ C/W$
$R_{\theta JA}$	Junction-to-Ambient Thermal Resistance			80	
W_T	Package Weight		0.22		oz
			6.1		gm
Torque	Maximum Mounting Torque (Screw Type = 6-32 or 3mm Machine)			10	lb•in
				1.1	N•m

APT Reserves the right to change, without notice, the specifications and information contained herein.

TO-247 Package Outline

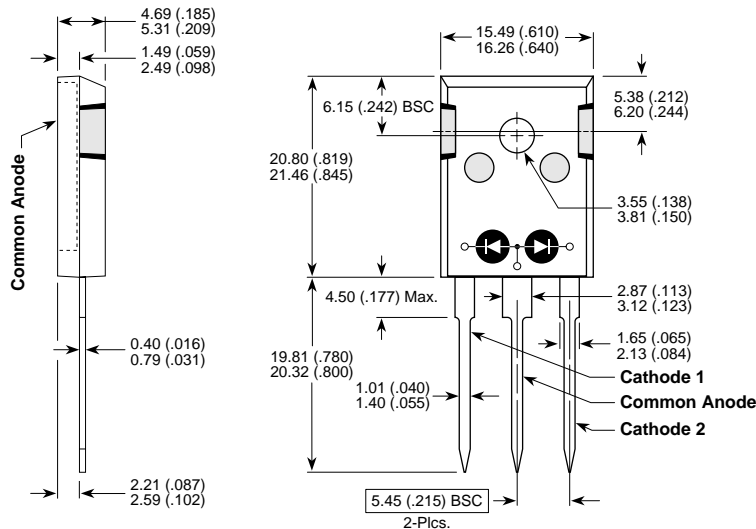

APT's devices are covered by one or more of the following U.S. patents: 4,895,810 5,045,903 5,089,434 5,182,234 5,019,522 5,262,336
 5,256,583 4,748,103 5,283,202 5,231,474 5,434,095 5,528,058