



STD2HNK60Z - STD2HNK60Z-1 STF2HNK60Z - STQ2HNK60ZR-AP

N-channel 600V - 4.4Ω - 2A - TO-92/TO-220FP/DPAK/IPAK
Zener-protected SuperMESH™ Power MOSFET

General features

Type	V _{DSS}	R _{DS(on)}	I _D	P _{TOT}
STD2HNK60Z	600V	<4.8Ω	2A	45W
STD2HNK60Z-1	600V	<4.8Ω	2A	45W
STF2HNK60Z	600V	<4.8Ω	2A	20W
STQ2HNK60ZR-AP	600V	<4.8Ω	0.5A	3W

- Gate charge minimized
- 100% avalanche tested
- Extremely high dv/dt capability
- ESD improved capability
- New high voltage benchmark

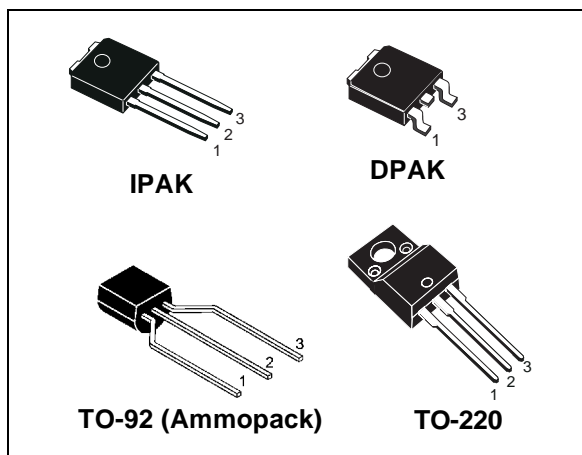

Description

The SuperMESH™ series is obtained through an extreme optimization of ST's well established stripbased PowerMESH™ layout. In addition to pushing on-resistance significantly down, special care is taken to ensure a very good dv/dt capability for the most demanding application. Such series complements ST full range of high voltage Power MOSFETs including revolutionary MDmesh™ products.

Applications

- Switching application

Internal schematic diagram

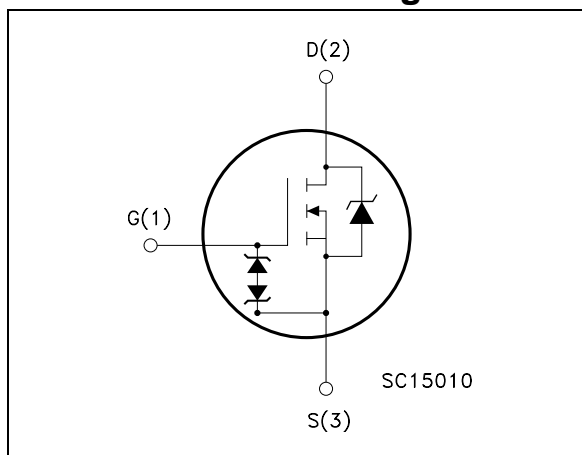

Order codes

Sales Type	Marking	Package	Packaging
STD2HNK60Z	D2HNK60Z	DPAK	Tape & reel
STD2HNK60Z-1	D2HNK60Z	IPAK	Tube
STF2HNK60Z	F2HNK60Z	TO-220FP	Tube
STQ2HNK60ZR-AP	Q2HNK60ZR	TO-92	Ammopak

Contents:

1	Electrical ratings	3
2	Electrical characteristics	4
2.1	Electrical characteristics (curves)	6
3	Test circuit	9
4	Package mechanical data	10
5	Revision history	13

1 Electrical ratings

Table 1. Absolute maximum ratings

Symbol	Parameter	Value			Unit
		I _{PAK} /DPAK	TO-220FP	TO-92	
V _{DS}	Drain-Source Voltage (V _{GS} = 0)	600			V
V _{DGR}	Drain-gate Voltage (R _{GS} = 20kΩ)	600			V
V _{GS}	Gate-Source Voltage	±30			V
I _D	Drain Current (continuous) at T _C = 25°C	2.0	2.0	0.5	A
I _D	Drain Current (continuous) at T _C =100°C	1.26	1.26	0.32	A
I _{DM} ⁽¹⁾	Drain Current (pulsed)	8	8	2	A
P _{TOT}	Total Dissipation at T _C = 25°C	45	20	3	W
	Derating Factor	0.36	0.16	0.025	W/°C
V _{ESD(G-S)}	Gate Source ESD (HBM-C=100pF, R=1.5kΩ)	2000			V
V _{ISO}	Insulation withstand voltage (DC)	--	2500	--	V
dv/dt ⁽²⁾	Peak Diode Recovery voltage slope	4.5			V/ns
T _J T _{stg}	Operating Junction Temperature Storage Temperature	-55 to 150			°C
T _I	Maximum lead temperature for soldering purpose	300		260	°C

1. Pulse width limited by safe operating area
2. I_{SD} ≤ 2A, di/dt ≤ 200A/μs, V_{DD} = 80% V_{(BR)DSS}

Table 2. Thermal data

		I _{PAK} /DPAK	TO-220FP	TO-92	
R _{thj-case}	Thermal resistance junction-case Max	2.77	6.25	--	°C/W
R _{thj-amb}	Thermal resistance junction-ambient Max	100	62.5	120	°C/W
R _{thj-lead}	Thermal resistance junction-lead Max	--	--	40	°C/W

Table 3. Avalanche data

Symbol	Parameter	Value	Unit
I _{AR}	Avalanche current, repetitive or not repetitive (pulse width limited by T _{jmax})	2	A
E _{AS}	Single pulse avalanche energy (starting T _J =25°C, I _D =I _{AR} , V _{DD} =50V)	120	mJ

2 Electrical characteristics

($T_{CASE}=25^{\circ}C$ unless otherwise specified)

Table 4. On/off states

Symbol	Parameter	Test Conditions	Min.	Typ.	Max.	Unit
$V_{(BR)DSS}$	Drain-Source Breakdown Voltage	$I_D = 1mA, V_{GS} = 0$	600			V
I_{DSS}	Zero Gate Voltage Drain Current ($V_{GS} = 0$)	$V_{DS} = \text{Max Rating},$ $V_{DS} = \text{Max Rating}, T_c=125^{\circ}C$			1 50	μA μA
I_{GSS}	Gate Body Leakage Current ($V_{DS} = 0$)	$V_{GS} = \pm 20V$			± 10	nA
$V_{GS(th)}$	Gate Threshold Voltage	$V_{DS} = V_{GS}, I_D = 50\mu A$	3	3.75	4.5	V
$R_{DS(on)}$	Static Drain-Source On Resistance	$V_{GS} = 10V, I_D = 1.0A$		4.4	4.8	Ω

Table 5. Dynamic

Symbol	Parameter	Test Conditions	Min.	Typ.	Max.	Unit
$g_{fs}^{(1)}$	Forward Transconductance	$V_{DS} = 15V, I_D = 1.0A$		1.5		S
C_{iss} C_{oss} C_{rss}	Input Capacitance Output Capacitance Reverse Transfer Capacitance	$V_{DS} = 25V, f = 1 \text{ MHz}, V_{GS} = 0$		280 38 7		pF pF pF
$C_{oss \text{ eq}}^{(2)}$	Equivalent Output Capacitance	$V_{GS} = 0, V_{DS} = 0V \text{ to } 480V$		30		pF
Q_g Q_{gs} Q_{gd}	Total Gate Charge Gate-Source Charge Gate-Drain Charge	$V_{DD} = 480V, I_D = 2.0A$ $V_{GS} = 10V$ (see Figure 18)		11 2.25 6	15	nC nC nC

1. Pulsed: pulse duration=300 μs , duty cycle 1.5%
2. $C_{oss \text{ eq}}$ is defined as a constant equivalent capacitance giving the same charging time as C_{oss} when V_{DS} increases from 0 to 80% V_{DSS}

Table 6. Switching times

Symbol	Parameter	Test Conditions	Min.	Typ.	Max.	Unit
$t_{d(on)}$ t_r	Turn-on Delay Time Rise Time	$V_{DD}=300V$, $I_D=1.0A$, $R_G=4.7\Omega$, $V_{GS}=10V$ (see Figure 17)		10 30		ns ns
$t_{d(off)}$ t_f	Turn-off Delay Time Fall Time	$V_{DD}=300V$, $I_D=1.0A$, $R_G=4.7\Omega$, $V_{GS}=10V$ (see Figure 17)		23 50		ns ns

Table 7. Source drain diode

Symbol	Parameter	Test Conditions	Min.	Typ.	Max.	Unit
I_{SD} $I_{SDM}^{(1)}$	Source-drain Current Source-drain Current (pulsed)				2.0 8.0	A A
$V_{SD}^{(2)}$	Forward on Voltage	$I_{SD}=2.0A$, $V_{GS}=0$			1.3	V
t_{rr} Q_{rr} I_{RRM}	Reverse Recovery Time Reverse Recovery Charge Reverse Recovery Current	$I_{SD}=2.0A$, $di/dt = 100A/\mu s$, $V_{DD}=20 V$, $T_j=25^\circ C$		178 445 5		ns nC A
t_{rr} Q_{rr} I_{RRM}	Reverse Recovery Time Reverse Recovery Charge Reverse Recovery Current	$I_{SD}=2.0A$, $di/dt = 100A/\mu s$, $V_{DD}=20 V$, $T_j=150^\circ C$		200 500 5		ns nC A

1. Pulse width limited by safe operating area
2. Pulsed: pulse duration=300 μs , duty cycle 1.5%

2.1 Electrical characteristics (curves)

Figure 1. Safe operating area for TO-92

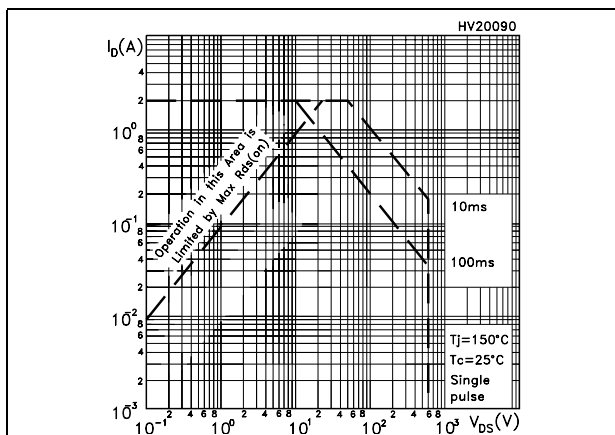

Figure 2. Thermal impedance for TO-92

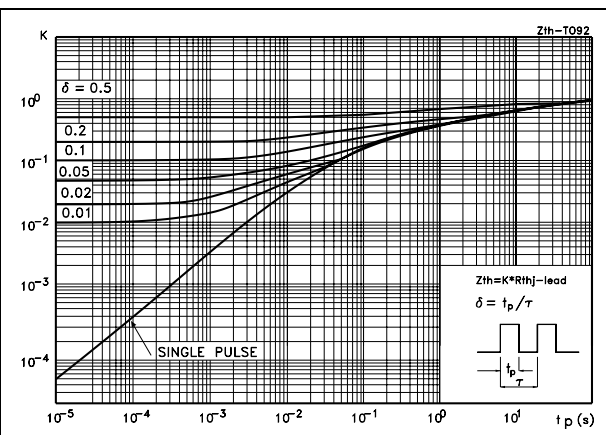

Figure 3. Safe operating area for TO-220FP

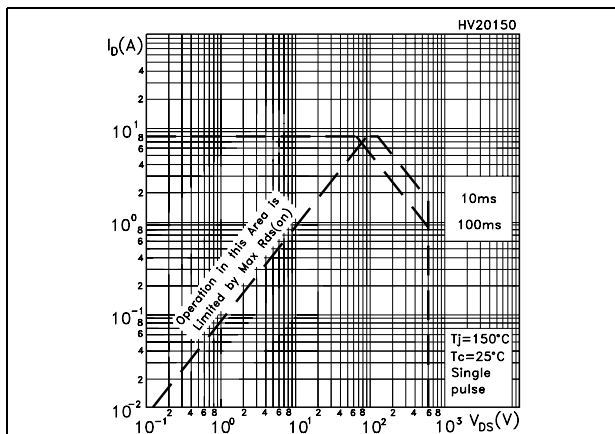

Figure 4. Thermal impedance for TO-220FP

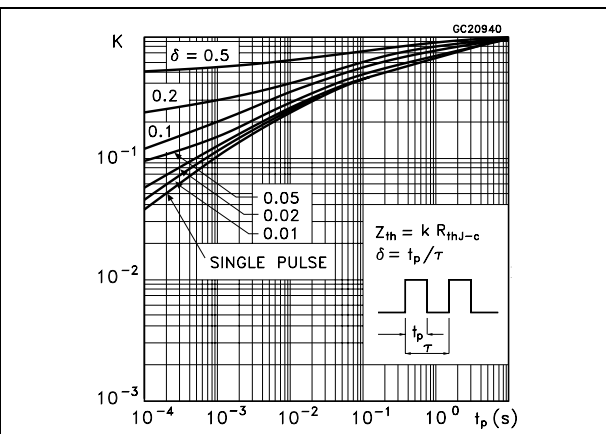

Figure 5. Safe operating area for IPAK/DPAK

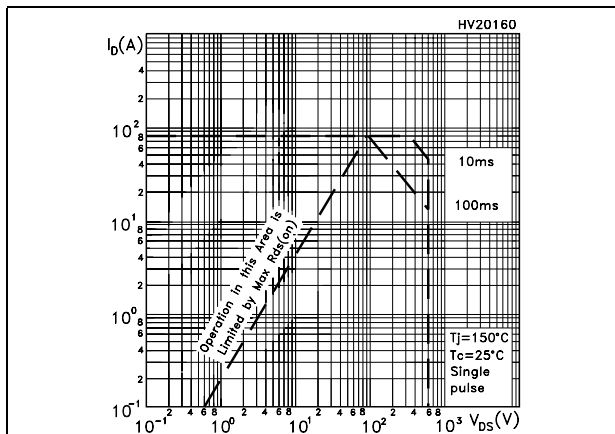

Figure 6. Thermal impedance for IPAK/DPAK

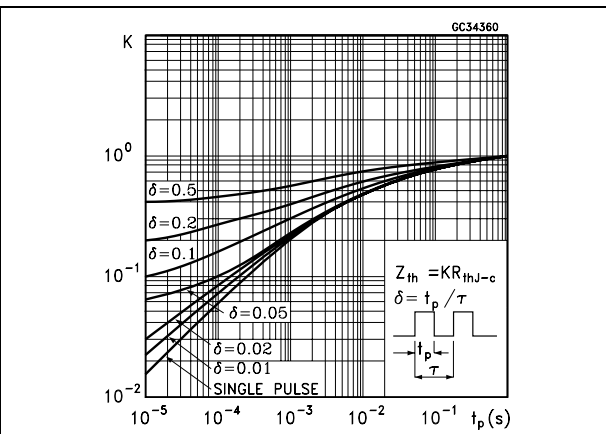

Figure 7. Output characteristics

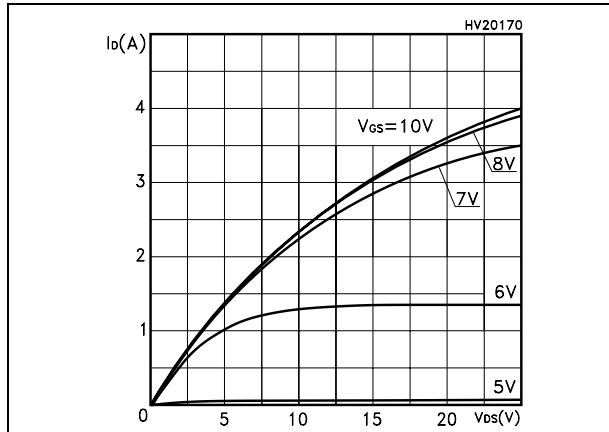

Figure 8. Transfer characteristics

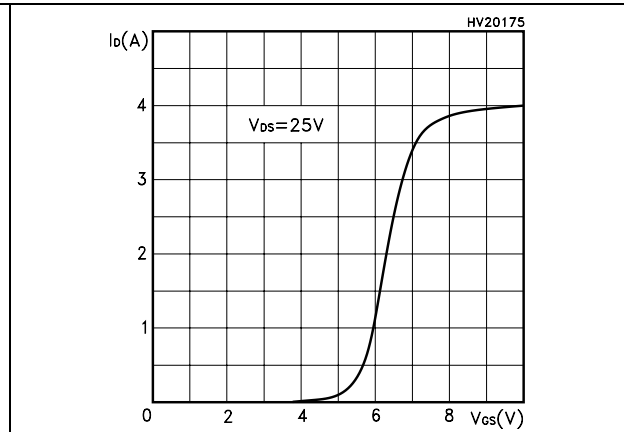

Figure 9. Normalized $B_{V_{DS}}$ vs temperature

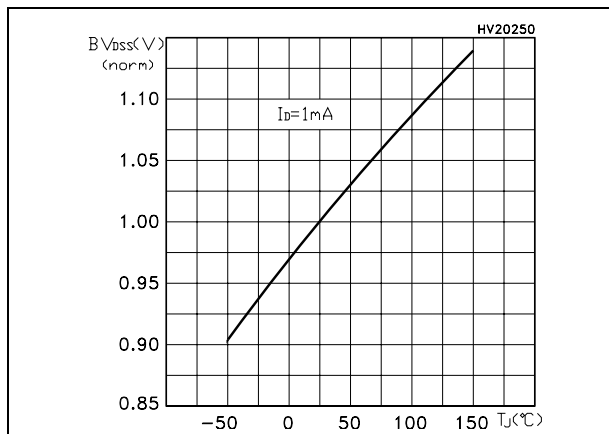

Figure 10. Static drain-source on resistance

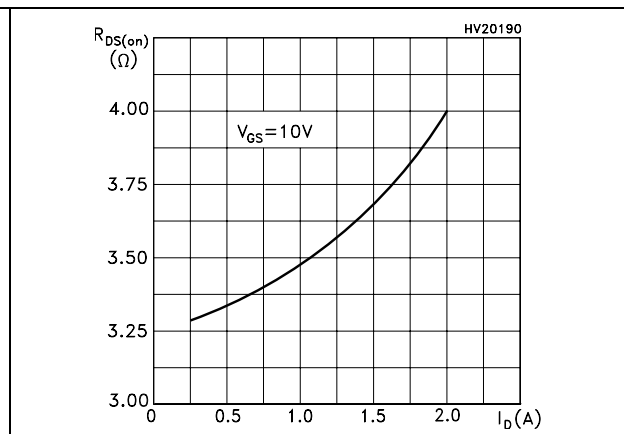

Figure 11. Gate charge vs gate-source voltage

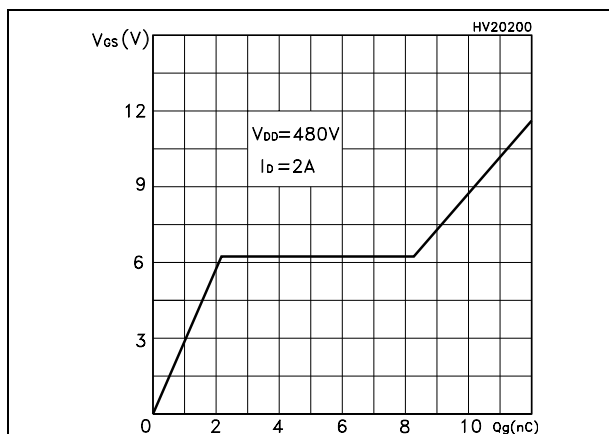

Figure 12. Capacitance variations

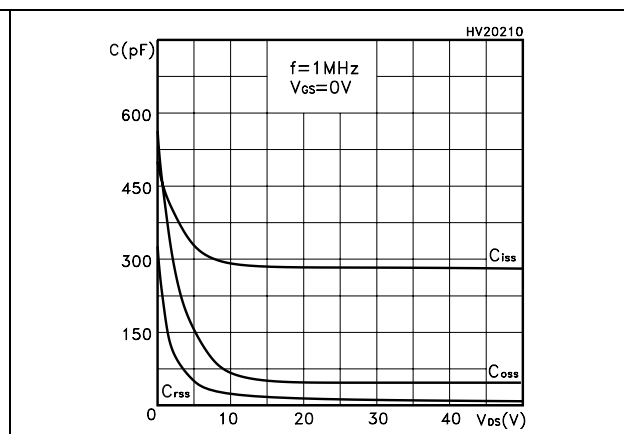

Figure 13. Normalized gate threshold voltage vs temperature

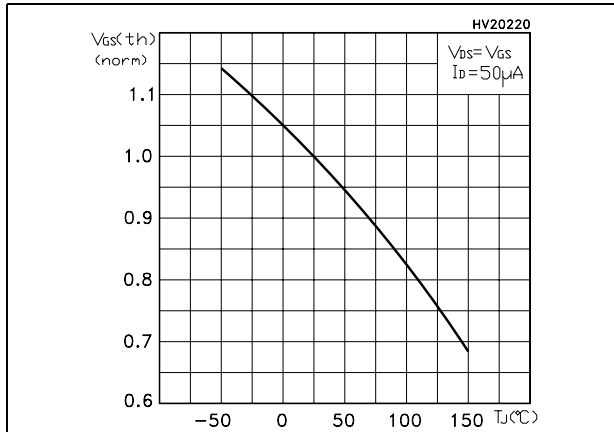

Figure 14. Normalized on resistance vs temperature

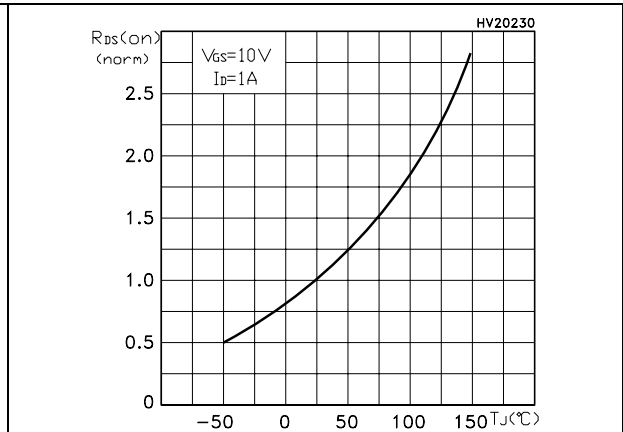

Figure 15. Source-drain diode forward characteristics

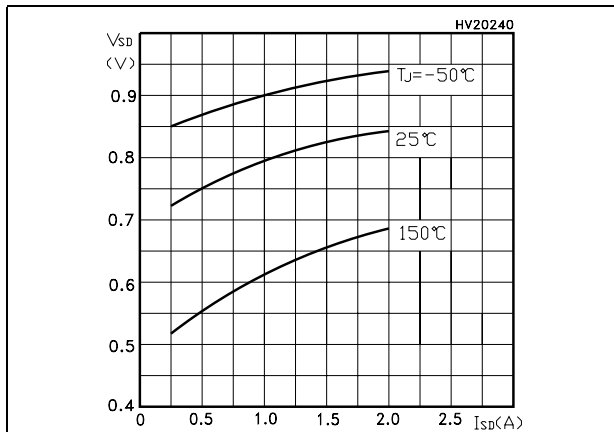
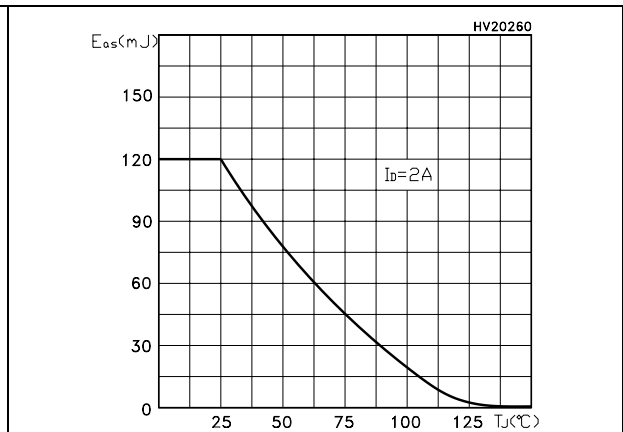

Figure 16. Maximum avalanche energy vs temperature



3 Test circuit

Figure 17. Switching times test circuit for resistive load

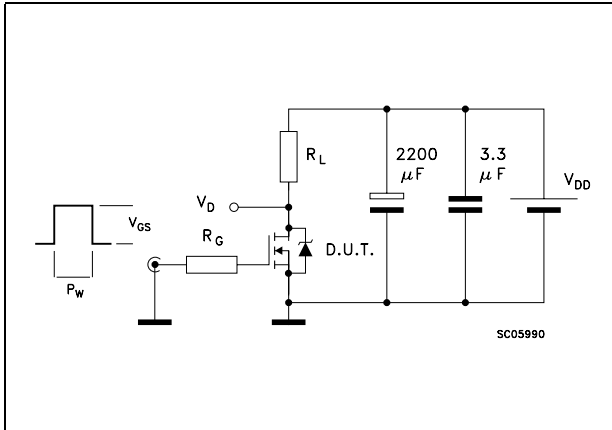

Figure 18. Gate charge test circuit

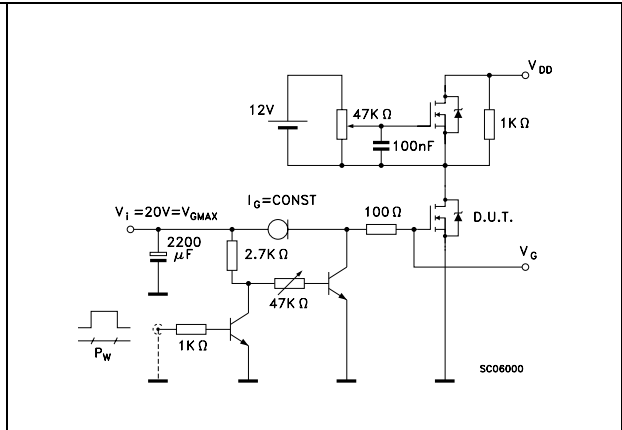

Figure 19. Test circuit for inductive load switching and diode recovery times

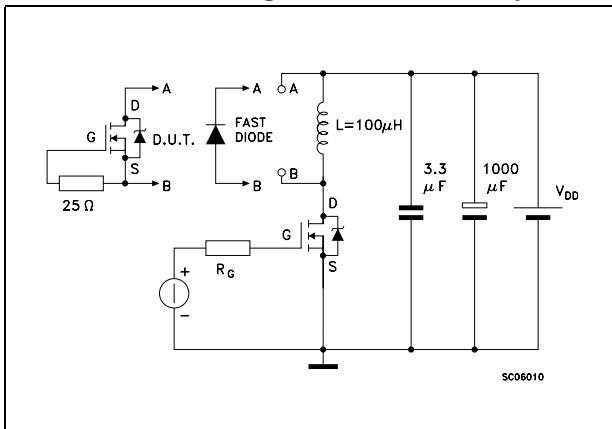

Figure 20. Unclamped inductive load test circuit

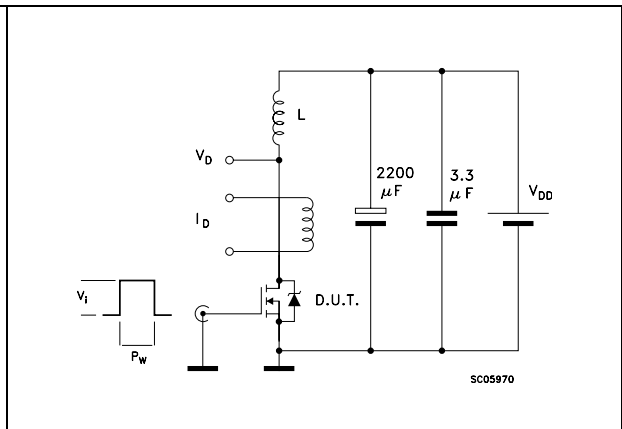

Figure 21. Unclamped inductive waveform

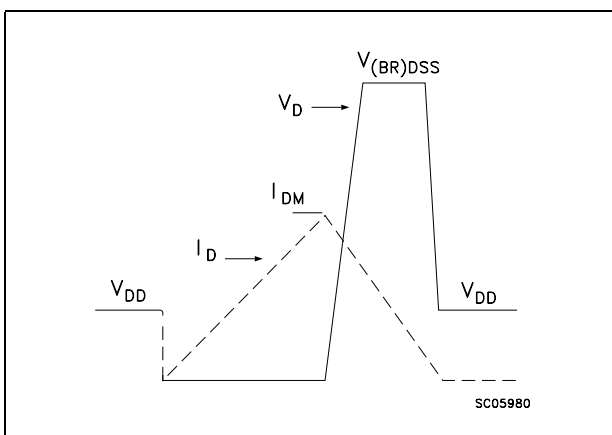
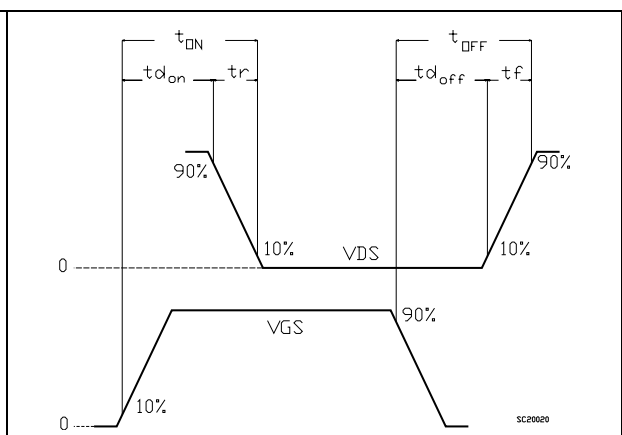

Figure 22. Switching time waveform



4 Package mechanical data

In order to meet environmental requirements, ST offers these devices in ECOPACK® packages. These packages have a Lead-free second level interconnect . The category of second level interconnect is marked on the package and on the inner box label, in compliance with JEDEC Standard JESD97. The maximum ratings related to soldering conditions are also marked on the inner box label. ECOPACK is an ST trademark. ECOPACK specifications are available at: www.st.com

TO-220FP MECHANICAL DATA

DIM.	mm.			inch		
	MIN.	TYP.	MAX.	MIN.	TYP.	MAX.
A	4.4		4.6	0.173		0.181
B	2.5		2.7	0.098		0.106
D	2.5		2.75	0.098		0.108
E	0.45		0.7	0.017		0.027
F	0.75		1	0.030		0.039
F1	1.15		1.7	0.045		0.067
F2	1.15		1.7	0.045		0.067
G	4.95		5.2	0.195		0.204
G1	2.4		2.7	0.094		0.106
H	10		10.4	0.393		0.409
L2		16			0.630	
L3	28.6		30.6	1.126		1.204
L4	9.8		10.6	.0385		0.417
L5	2.9		3.6	0.114		0.141
L6	15.9		16.4	0.626		0.645
L7	9		9.3	0.354		0.366
∅	3		3.2	0.118		0.126

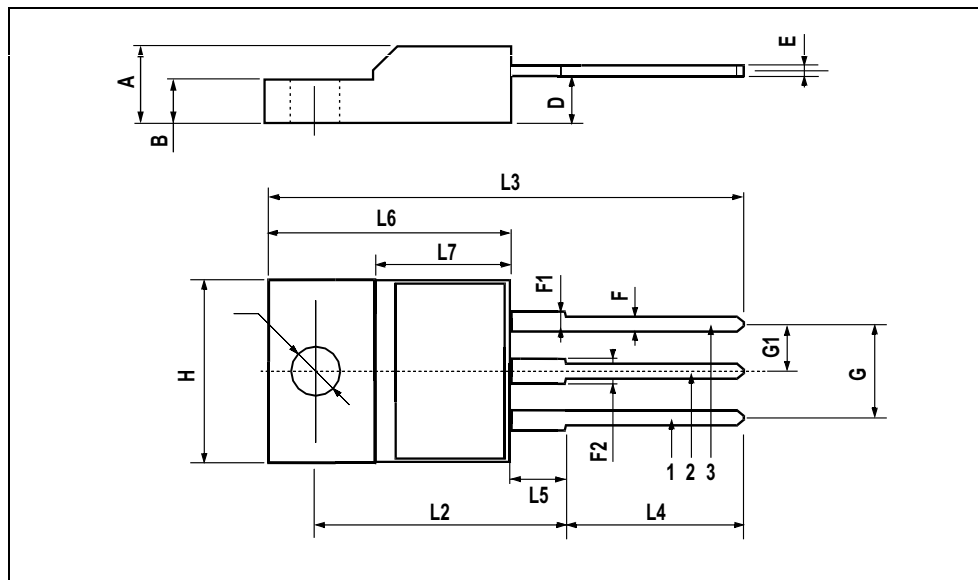

TO-251 (IPAK) MECHANICAL DATA

DIM.	mm			inch		
	MIN.	TYP.	MAX.	MIN.	TYP.	MAX.
A	2.2		2.4	0.086		0.094
A1	0.9		1.1	0.035		0.043
A3	0.7		1.3	0.027		0.051
B	0.64		0.9	0.025		0.031
B2	5.2		5.4	0.204		0.212
B3			0.85			0.033
B5		0.3			0.012	
B6			0.95			0.037
C	0.45		0.6	0.017		0.023
C2	0.48		0.6	0.019		0.023
D	6		6.2	0.236		0.244
E	6.4		6.6	0.252		0.260
G	4.4		4.6	0.173		0.181
H	15.9		16.3	0.626		0.641
L	9		9.4	0.354		0.370
L1	0.8		1.2	0.031		0.047
L2		0.8	1		0.031	0.039

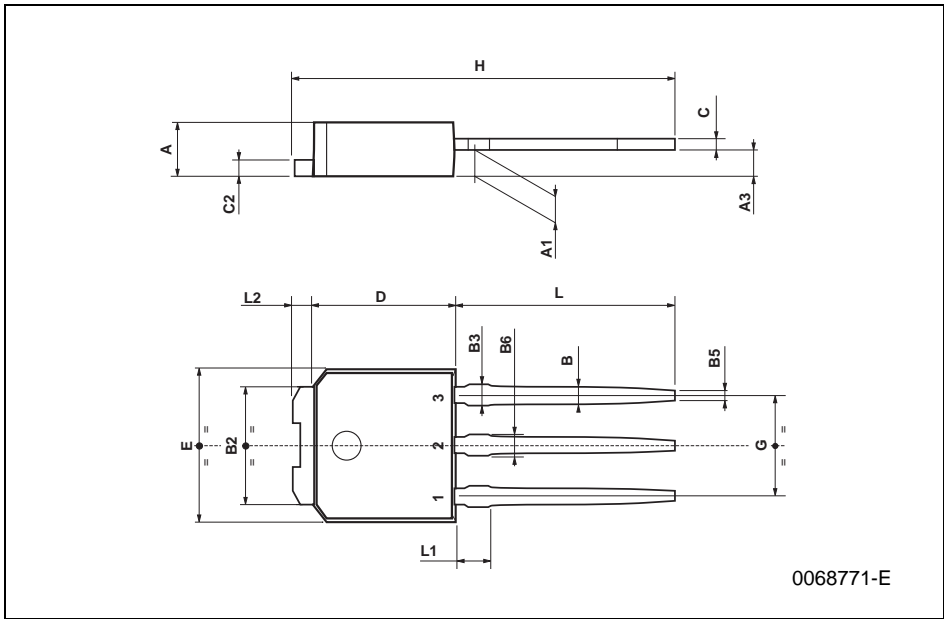

TO-252 (DPAK) MECHANICAL DATA

DIM.	mm			inch		
	MIN.	TYP.	MAX.	MIN.	TYP.	MAX.
A	2.20		2.40	0.087		0.094
A1	0.90		1.10	0.035		0.043
A2	0.03		0.23	0.001		0.009
B	0.64		0.90	0.025		0.035
B2	5.20		5.40	0.204		0.213
C	0.45		0.60	0.018		0.024
C2	0.48		0.60	0.019		0.024
D	6.00		6.20	0.236		0.244
E	6.40		6.60	0.252		0.260
G	4.40		4.60	0.173		0.181
H	9.35		10.10	0.368		0.398
L2		0.8			0.031	
L4	0.60		1.00	0.024		0.039
V2	0°		8°	0°		0°

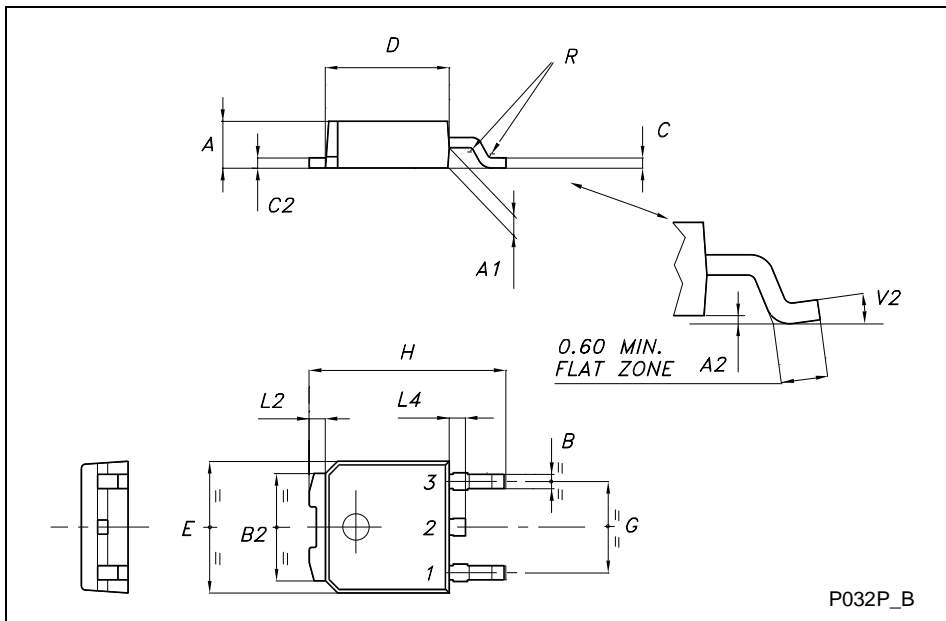

TO-92 AMMOPACK

DIM.	mm.			inch		
	MIN.	TYP.	MAX.	MIN.	TYP.	MAX.
A1	4.45		4.95	0.170		0.194
T	3.30		3.94	0.130		0.155
T1			1.6			0.06
T2			2.3			0.09
d	0.41		0.56	0.016		0.022
P0	12.5	12.7	12.9	0.49	0.5	0.51
P2	5.65	6.35	7.05	0.22	0.25	0.27
F1, F2	2.44	2.54	2.94	0.09	0.1	0.11
delta H	-2		2	-0.08		0.08
W	17.5	18	19	0.69	0.71	0.74
W0	5.7	6	6.3	0.22	0.23	0.24
W1	8.5	9	9.25	0.33	0.35	0.36
W2			0.5			0.02
H	18.5		20.5	0.72		0.80
H0	15.5	16	16.5	0.61	0.63	0.65
H1			25			0.98
D0	3.8	4	4.2	0.15	0.157	0.16
t			0.9			0.035
L			11			0.43
I1	3			0.11		
delta P	-1		1	-0.04		0.04

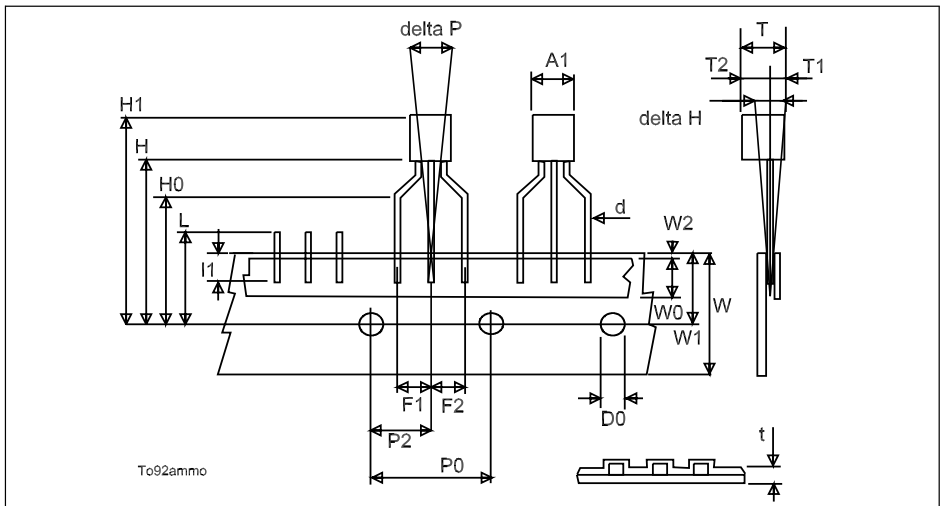

5 Revision history

Table 8. Revision history

Date	Revision	Changes
09-Mar-2004	1	First release
23-Mar-2004	2	Modified title
02-Apr-2005	3	Complete version
06-Mar-2006	4	Inserted DPAK. New template

Please Read Carefully:

Information in this document is provided solely in connection with ST products. STMicroelectronics NV and its subsidiaries ("ST") reserve the right to make changes, corrections, modifications or improvements, to this document, and the products and services described herein at any time, without notice.

All ST products are sold pursuant to ST's terms and conditions of sale.

Purchasers are solely responsible for the choice, selection and use of the ST products and services described herein, and ST assumes no liability whatsoever relating to the choice, selection or use of the ST products and services described herein.

No license, express or implied, by estoppel or otherwise, to any intellectual property rights is granted under this document. If any part of this document refers to any third party products or services it shall not be deemed a license grant by ST for the use of such third party products or services, or any intellectual property contained therein or considered as a warranty covering the use in any manner whatsoever of such third party products or services or any intellectual property contained therein.

UNLESS OTHERWISE SET FORTH IN ST'S TERMS AND CONDITIONS OF SALE ST DISCLAIMS ANY EXPRESS OR IMPLIED WARRANTY WITH RESPECT TO THE USE AND/OR SALE OF ST PRODUCTS INCLUDING WITHOUT LIMITATION IMPLIED WARRANTIES OF MERCHANTABILITY, FITNESS FOR A PARTICULAR PURPOSE (AND THEIR EQUIVALENTS UNDER THE LAWS OF ANY JURISDICTION), OR INFRINGEMENT OF ANY PATENT, COPYRIGHT OR OTHER INTELLECTUAL PROPERTY RIGHT.

UNLESS EXPRESSLY APPROVED IN WRITING BY AN AUTHORIZED REPRESENTATIVE OF ST, ST PRODUCTS ARE NOT DESIGNED, AUTHORIZED OR WARRANTED FOR USE IN MILITARY, AIR CRAFT, SPACE, LIFE SAVING, OR LIFE SUSTAINING APPLICATIONS, NOR IN PRODUCTS OR SYSTEMS, WHERE FAILURE OR MALFUNCTION MAY RESULT IN PERSONAL INJURY, DEATH, OR SEVERE PROPERTY OR ENVIRONMENTAL DAMAGE.

Resale of ST products with provisions different from the statements and/or technical features set forth in this document shall immediately void any warranty granted by ST for the ST product or service described herein and shall not create or extend in any manner whatsoever, any liability of ST.

ST and the ST logo are trademarks or registered trademarks of ST in various countries.

Information in this document supersedes and replaces all information previously supplied.

The ST logo is a registered trademark of STMicroelectronics. All other names are the property of their respective owners.

© 2006 STMicroelectronics - All rights reserved

STMicroelectronics group of companies

Australia - Belgium - Brazil - Canada - China - Czech Republic - Finland - France - Germany - Hong Kong - India - Israel - Italy - Japan - Malaysia - Malta - Morocco - Singapore - Spain - Sweden - Switzerland - United Kingdom - United States of America

www.st.com