



# STP6NK70Z STF6NK70Z - STW6NK70Z

N-channel 700V - 1.5Ω - 5A - TO-220/TO-220FP  
Zener-protected SuperMESH™ Power MOSFET

## General features

Type	V <sub>DSS</sub> (@T <sub>jmax</sub> )	R <sub>DS(on)</sub>	I <sub>D</sub>
STP6NK70Z	700 V	< 1.8 Ω	5 A
STF6NK70Z	700 V	< 1.8 Ω	5 A <sup>(1)</sup>
STW6NK70Z	700 V	< 1.8 Ω	5 A

1. Limited only by maximum temperature allowed

- Extremely high dv/dt capability
- Improved esd capability
- 100% avalanche rated
- Gate charge minimized
- Very low intrinsic capacitances
- Very good manufacturing repeatability

## Description

The SuperMESH™ series is obtained through an extreme optimization of ST's well established strippbased PowerMESH™ layout. In addition to pushing on-resistance significantly down, special care is taken to ensure a very good dv/dt capability for the most demanding applications. Such series complements ST full range of high voltage MOSFETs including revolutionary MDmesh™ products.

## Applications

- Switching application

## Order codes

Part number	Marking	Package	Packaging
STP6NK70Z	P6NK70Z	TO-220	Tube
STF6NK70Z	F6NK70Z	TO-220FP	Tube
STW6NK70Z	W5NK90Z	TO-247	Tube

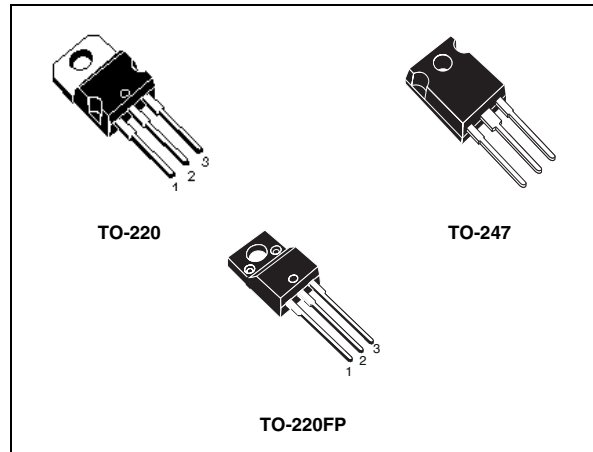

## Internal schematic diagram

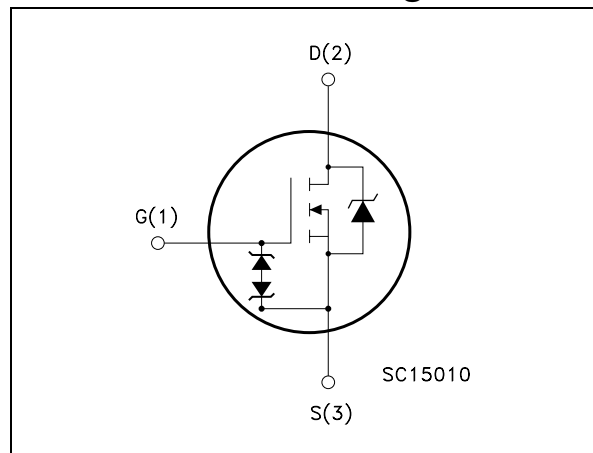

## Contents

<b>1</b>	<b>Electrical ratings</b> .....	<b>3</b>
	1.1 Protection features of gate-to-source zener diodes .....	4
<b>2</b>	<b>Electrical characteristics</b> .....	<b>5</b>
	2.1 Electrical characteristics (curves) .....	7
<b>3</b>	<b>Test circuit</b> .....	<b>10</b>
<b>4</b>	<b>Package mechanical data</b> .....	<b>11</b>
<b>5</b>	<b>Revision history</b> .....	<b>15</b>

# 1 Electrical ratings

**Table 1. Absolute maximum ratings**

Symbol	Parameter	Value		Unit
		TO-220/TO-247	TO-220FP	
$V_{DS}$	Drain-source voltage ( $V_{GS} = 0$ )	700		V
$V_{GS}$	Gate-source voltage	$\pm 30$		V
$I_D$	Drain current (continuous) at $T_C = 25^\circ\text{C}$	5	5 <sup>(2)</sup>	A
$I_D$	Drain current (continuous) at $T_C = 100^\circ\text{C}$	3.15	3.15 <sup>(2)</sup>	A
$I_{DM}^{(1)}$	Drain current (pulsed)	20	20 <sup>(2)</sup>	A
$P_{TOT}$	Total dissipation at $T_C = 25^\circ\text{C}$	110	30	W
	Derating factor	0.87	0.24	W/°C
$V_{ESD(G-S)}$	Gate source ESD (HBM-C=100pF, R=1.5K $\Omega$ )	4000		V
$dv/dt^{(3)}$	Peak diode recovery voltage slope	4.5		V/ns
$V_{ISO}$	Insulation withstand voltage (RMS) from all three leads to external heat sink (t=1s; $T_C = 25^\circ\text{C}$ )	-	2500	V
$T_J$ $T_{stg}$	Operating junction temperature Storage temperature	-55 to 150		°C

1. Pulse width limited by safe operation area
2. Limited only by maximum temperature allowed
3.  $I_{SD} \leq 5$  A,  $di/dt \leq 100$  A/ $\mu$ s,  $V_{DD} \leq V_{(BR)DSS}$ ,  $T_J \leq T_{JMAX}$

**Table 2. Thermal data**

Symbol	Parameter	Value		Unit
		TO-220/TO-247	TO-220FP	
$R_{thj-case}$	Thermal resistance junction-case max	1.14	4.2	°C/W
$R_{thj-a}$	Thermal resistance junction-ambient max	62.5		°C/W
$T_l$	Maximum lead temperature for soldering purpose	300		°C

**Table 3. Avalanche characteristics**

Symbol	Parameter	Max Value	Unit
$I_{AS}$	Avalanche current, repetitive or not-repetitive (pulse width limited by $T_j$ Max)	5	A
$E_{AS}$	Single pulse avalanche energy (starting $T_j=25^\circ\text{C}$ , $I_d=I_{ar}$ , $V_{dd}=50\text{V}$ )	200	mJ

**Table 4. Gate-source zener diode**

Symbol	Parameter	Test conditions	Min	Typ.	Max	Unit
$BV_{GSO}$	Gate-Source breakdown voltage	$I_{gs}=\pm 1\text{mA}$ (Open drain)	30			V

## 1.1 Protection features of gate-to-source zener diodes

The built-in back-to-back Zener diodes have specifically been designed to enhance not only the device's ESD capability, but also to make them safely absorb possible voltage transients that may occasionally be applied from gate to source. In this respect the Zener voltage is appropriate to achieve an efficient and cost-effective intervention to protect the device's integrity. These integrated Zener diodes thus avoid the usage of external components.

## 2 Electrical characteristics

( $T_{CASE}=25^{\circ}C$  unless otherwise specified)

**Table 5. On/off states**

Symbol	Parameter	Test conditions	Min.	Typ.	Max.	Unit
$V_{(BR)DSS}$	Drain-source breakdown voltage	$I_D = 1mA, V_{GS} = 0$	700			V
$I_{DSS}$	Zero gate voltage drain current ( $V_{GS} = 0$ )	$V_{DS} = \text{Max rating},$ $V_{DS} = \text{Max rating}, T_c=125^{\circ}C$			1 50	$\mu A$ $\mu A$
$I_{GSS}$	Gate body leakage current ( $V_{GS} = 0$ )	$V_{GS} = \pm 20V$			$\pm 10$	$\mu A$
$V_{GS(th)}$	Gate threshold voltage	$V_{DS} = V_{GS}, I_D = 100\mu A$	3	3.75	4.5	V
$R_{DS(on)}$	Static drain-source on resistance	$V_{GS} = 10 V, I_D = 2.5 A$		1.5	1.8	$\Omega$

**Table 6. Dynamic**

Symbol	Parameter	Test conditions	Min.	Typ.	Max.	Unit
$g_{fs}^{(1)}$	Forward transconductance	$V_{DS} = 15V, I_D = 2.5A$		4.4		S
$C_{iss}$	Input capacitance	$V_{DS} = 25V, f = 1 \text{ MHz}, V_{GS} = 0$		930		pF
$C_{oss}$	Output capacitance			105		pF
$C_{rss}$	Reverse transfer capacitance			22		pF
$C_{osseq}^{(2)}$	Equivalent output capacitance	$V_{GS} = 0, V_{DS} = 0V \text{ to } 560V$		70		pF
$t_{d(on)}$	Turn-on delay time	$V_{DD} = 350 V, I_D = 2.5 A,$ $R_G = 4.7\Omega, V_{GS} = 10V$ (see <a href="#">Figure 18</a> )		17		ns
$t_r$	Rise time			18		ns
$t_{d(off)}$	Off-voltage rise time			45		ns
$t_f$	Fall time			30		ns
$Q_g$	Total gate charge	$V_{DD} = 560V, I_D = 5A$		34	47	nC
$Q_{gs}$	Gate-source charge	$V_{GS} = 10V$		6.5		nC
$Q_{gd}$	Gate-drain charge	(see <a href="#">Figure 19</a> )		17		nC

1. Pulsed: pulse duration=300 $\mu s$ , duty cycle 1.5%

2.  $C_{oss \text{ eq}}$  is defined as a constant equivalent capacitance giving the same charging time as  $C_{oss}$  when  $V_{DS}$  increases from 0 to 80%  $V_{DSS}$

**Table 7. Source drain diode**

Symbol	Parameter	Test conditions	Min	Typ.	Max	Unit
$I_{SD}$	Source-drain current				5	A
$I_{SDM}^{(1)}$	Source-drain current (pulsed)				20	A
$V_{SD}^{(2)}$	Forward on voltage	$I_{SD} = 5 \text{ A}$ , $V_{GS}=0$			1.6	V
$t_{rr}$	Reverse recovery time	$I_{SD} = 5 \text{ A}$ , $di/dt = 100 \text{ A}/\mu\text{s}$ , $V_{DD} = 35 \text{ V}$ (see <a href="#">Figure 20</a> )		432		ns
$Q_{rr}$	Reverse recovery charge			2.37		$\mu\text{C}$
$I_{RRM}$	Reverse recovery current			11		A
$t_{rr}$	Reverse recovery time	$I_{SD} = 5 \text{ A}$ , $di/dt = 100 \text{ A}/\mu\text{s}$ , $V_{DD} = 35 \text{ V}$ , $T_j = 150 \text{ }^\circ\text{C}$ (see <a href="#">Figure 20</a> )		588		ns
$Q_{rr}$	Reverse recovery charge			3.38		$\mu\text{C}$
$I_{RRM}$	Reverse recovery current			11.5		A

1. Pulse width limited by safe operating area
2. Pulsed: pulse duration=300 $\mu\text{s}$ , duty cycle 1.5%

## 2.1 Electrical characteristics (curves)

Figure 1. Safe operating area

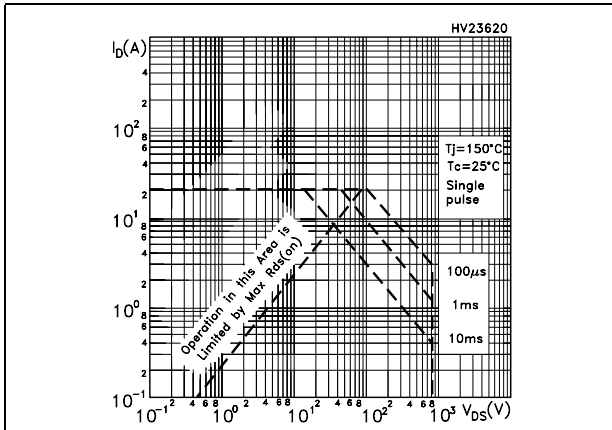

Figure 2. Thermal impedance

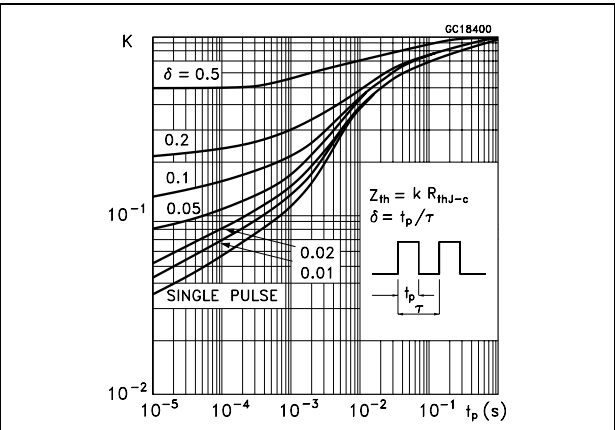

Figure 3. Safe operating area for TO-220FP

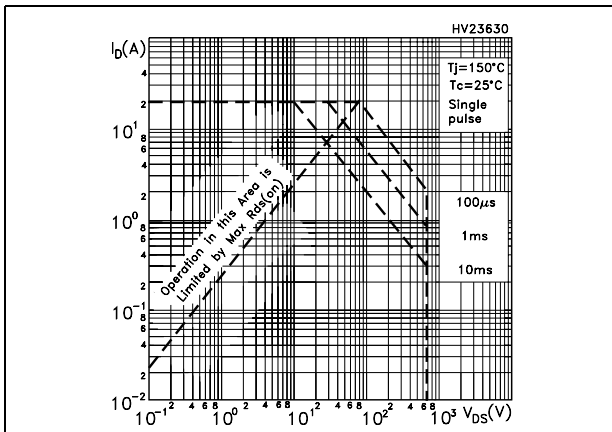

Figure 4. Thermal impedance for TO-220FP

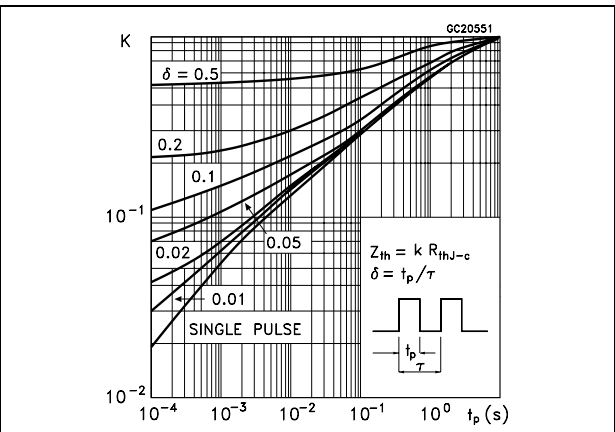

Figure 5. Safe operating area for TO-247

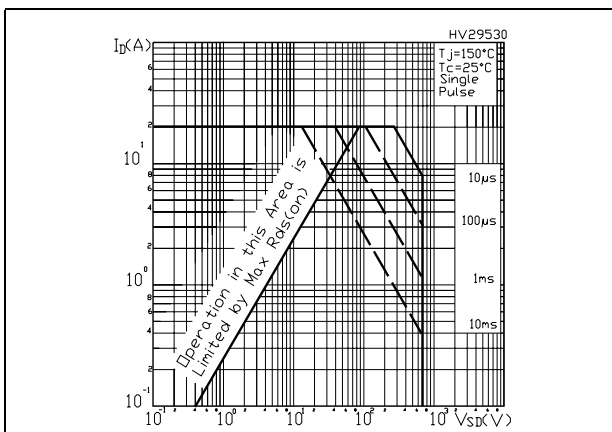

Figure 6. Thermal impedance for TO-247

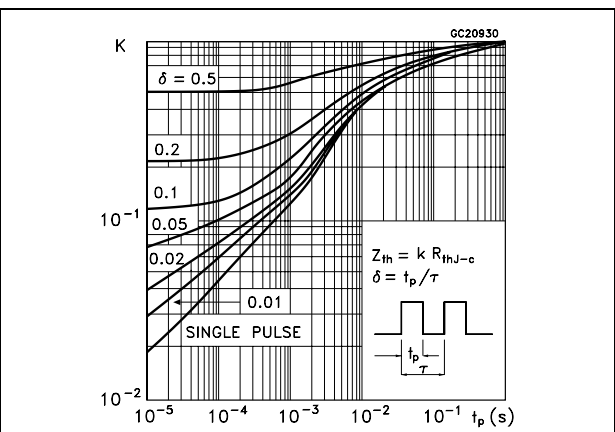

Figure 7. Output characteristics

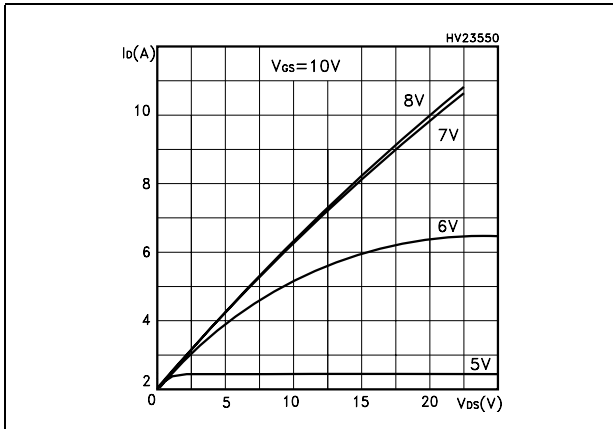

Figure 8. Transfer characteristics

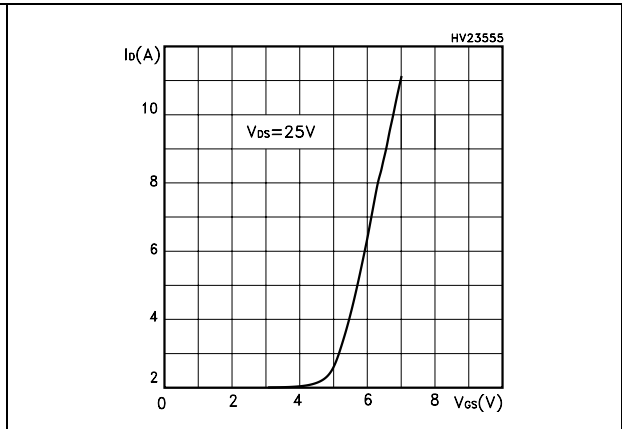

Figure 9. Transconductance

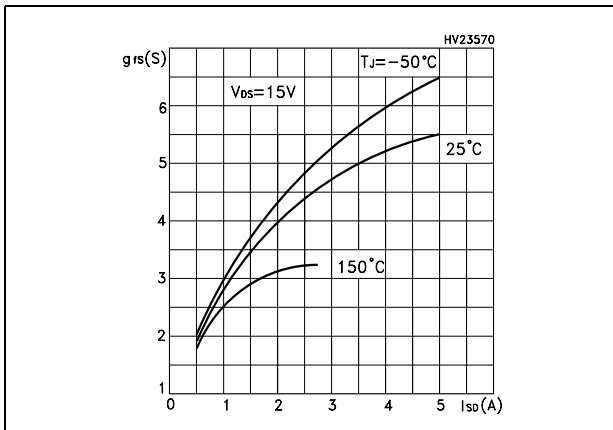

Figure 10. Static drain-source on resistance

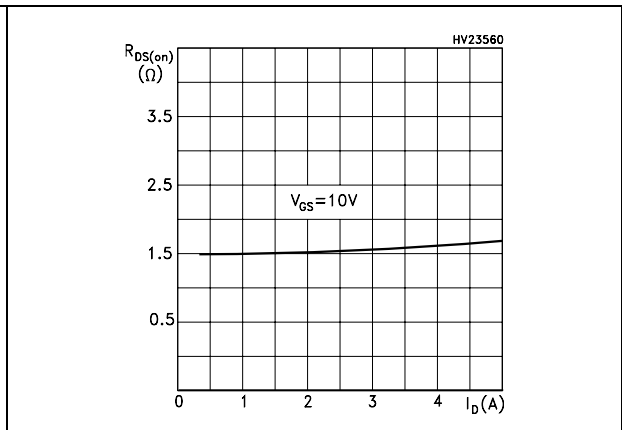

Figure 11. Gate charge vs gate-source voltage

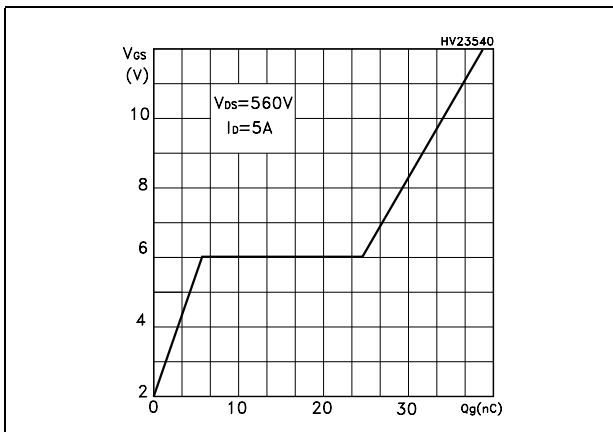

Figure 12. Capacitance variations

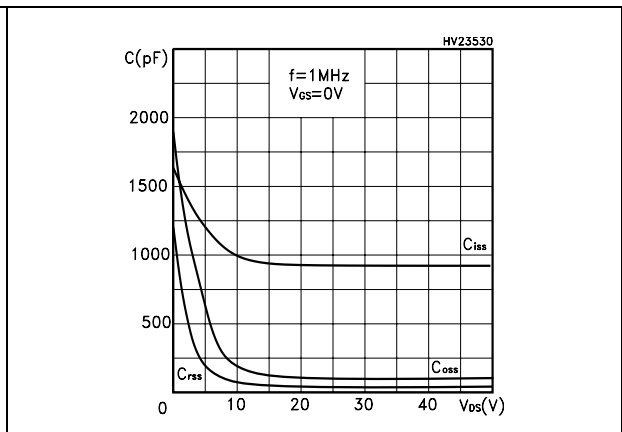



Figure 13. Source-drain diode forward characteristics

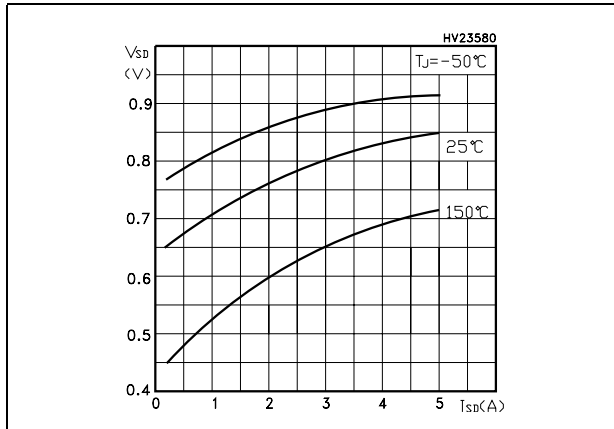

Figure 14. Normalized  $BV_{dss}$  vs temperature characteristics

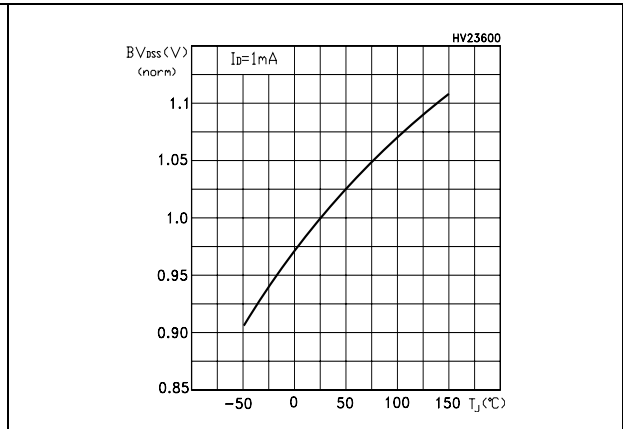
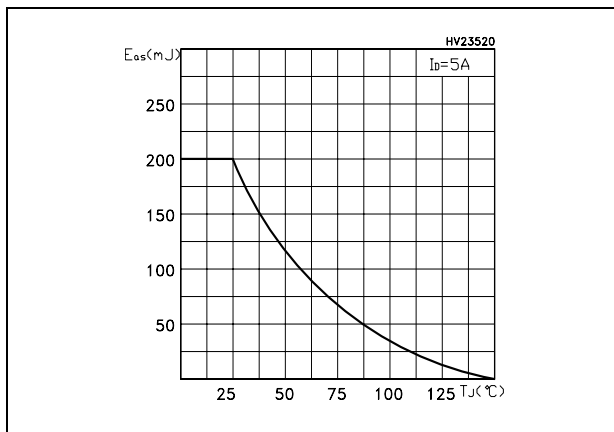

Figure 15. Avalanche Energy vs starting  $T_j$



### 3 Test circuit

Figure 16. Unclamped inductive load test circuit

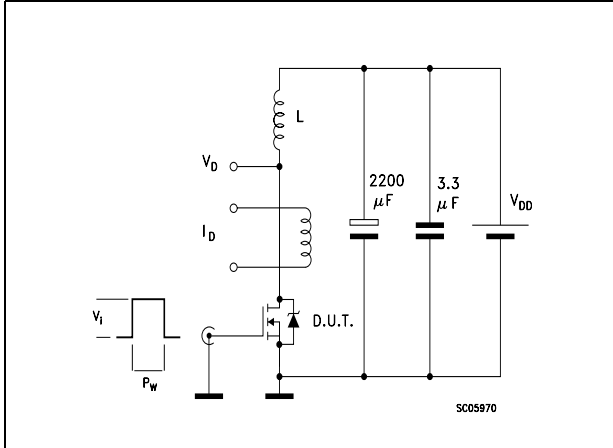

Figure 17. Unclamped inductive waveform

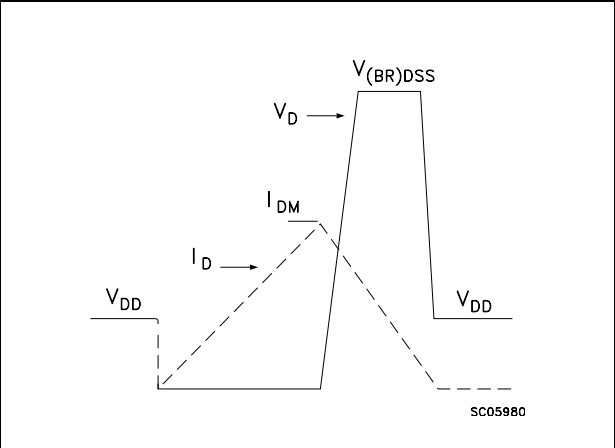

Figure 18. Switching times test circuit for resistive load

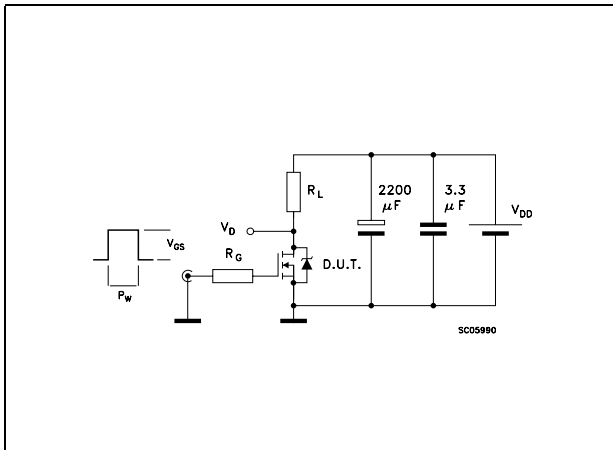

Figure 19. Gate charge test circuit

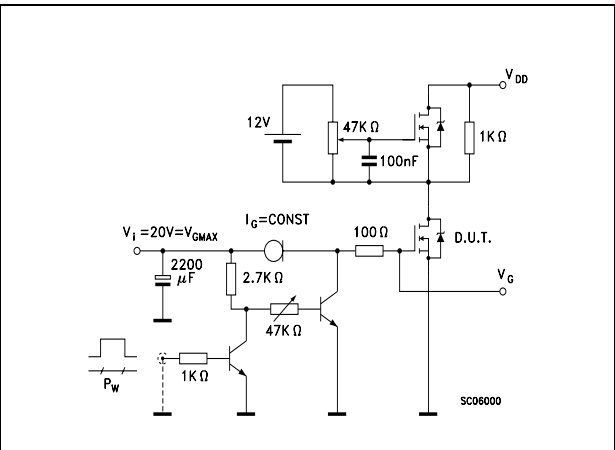
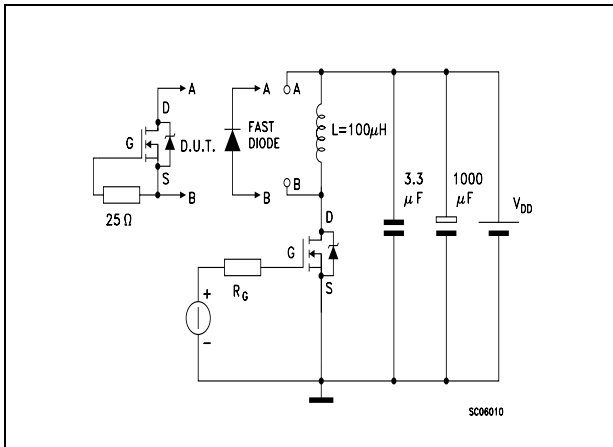

Figure 20. Test circuit for inductive load switching and diode recovery times



## 4 Package mechanical data

In order to meet environmental requirements, ST offers these devices in ECOPACK® packages. These packages have a Lead-free second level interconnect . The category of second level interconnect is marked on the package and on the inner box label, in compliance with JEDEC Standard JESD97. The maximum ratings related to soldering conditions are also marked on the inner box label. ECOPACK is an ST trademark. ECOPACK specifications are available at: [www.st.com](http://www.st.com)

**TO-247 MECHANICAL DATA**

DIM.	mm.			inch		
	MIN.	TYP.	MAX.	MIN.	TYP.	MAX.
A	4.85		5.15	0.19		0.20
A1	2.20		2.60	0.086		0.102
b	1.0		1.40	0.039		0.055
b1	2.0		2.40	0.079		0.094
b2	3.0		3.40	0.118		0.134
c	0.40		0.80	0.015		0.03
D	19.85		20.15	0.781		0.793
E	15.45		15.75	0.608		0.620
e		5.45			0.214	
L	14.20		14.80	0.560		0.582
L1	3.70		4.30	0.14		0.17
L2		18.50			0.728	
øP	3.55		3.65	0.140		0.143
øR	4.50		5.50	0.177		0.216
S		5.50			0.216	

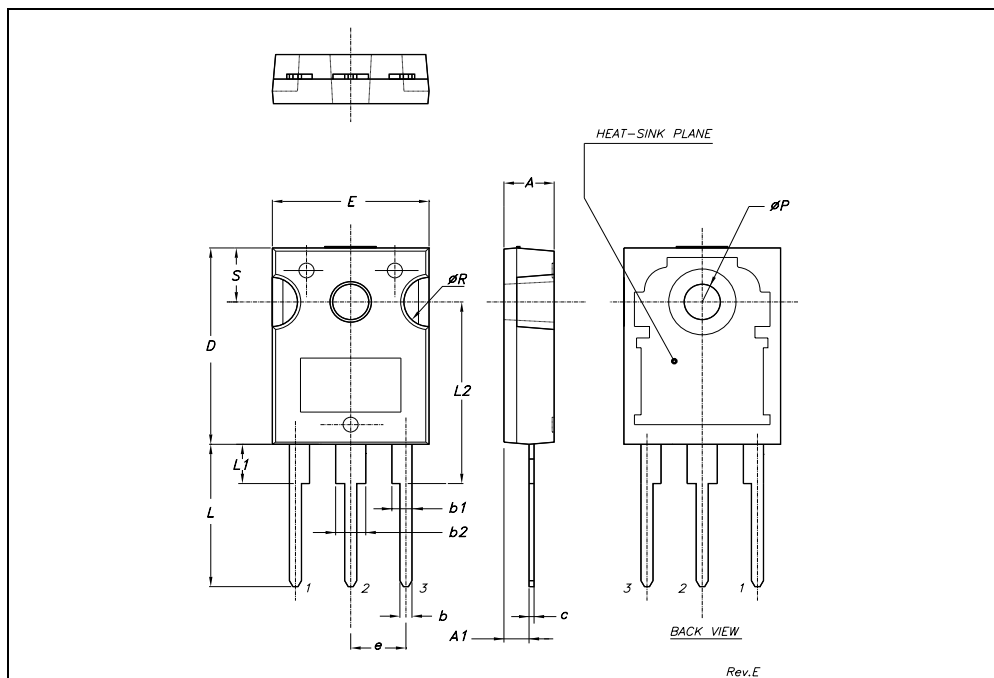



**TO-220FP MECHANICAL DATA**

DIM.	mm.			inch		
	MIN.	TYP.	MAX.	MIN.	TYP.	MAX.
A	4.4		4.6	0.173		0.181
B	2.5		2.7	0.098		0.106
D	2.5		2.75	0.098		0.108
E	0.45		0.7	0.017		0.027
F	0.75		1	0.030		0.039
F1	1.15		1.7	0.045		0.067
F2	1.15		1.7	0.045		0.067
G	4.95		5.2	0.195		0.204
G1	2.4		2.7	0.094		0.106
H	10		10.4	0.393		0.409
L2		16			0.630	
L3	28.6		30.6	1.126		1.204
L4	9.8		10.6	.0385		0.417
L5	2.9		3.6	0.114		0.141
L6	15.9		16.4	0.626		0.645
L7	9		9.3	0.354		0.366
Ø	3		3.2	0.118		0.126

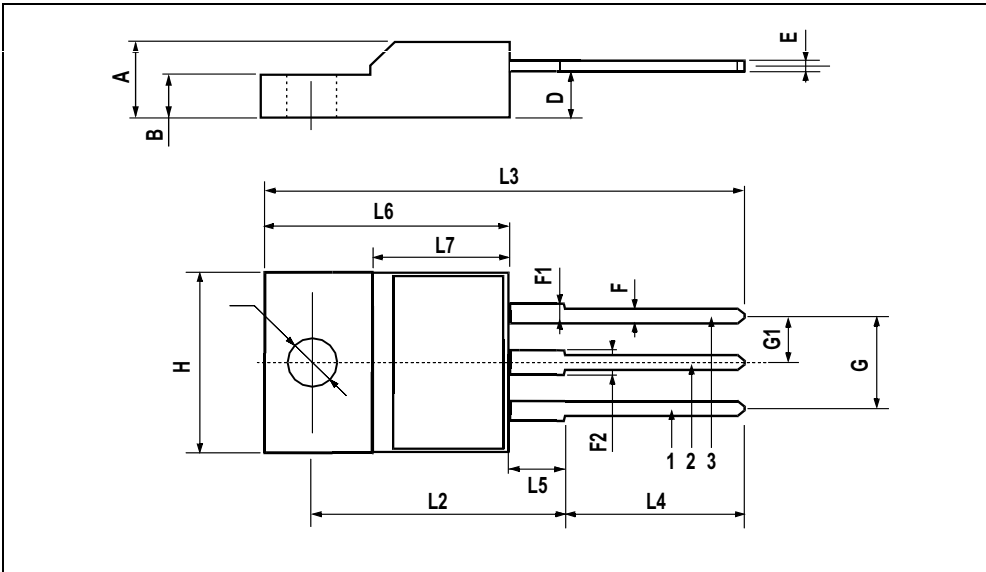

## 5 Revision history

**Table 8. Revision history**

<b>Date</b>	<b>Revision</b>	<b>Changes</b>
12-Nov-2004	1	First release
08-Sep-2004	2	Complete version with curves
06-Sep-2005	3	Inserted Ecopack indication
16-Aug-2006	4	New template, no content change

**Please Read Carefully:**

Information in this document is provided solely in connection with ST products. STMicroelectronics NV and its subsidiaries ("ST") reserve the right to make changes, corrections, modifications or improvements, to this document, and the products and services described herein at any time, without notice.

All ST products are sold pursuant to ST's terms and conditions of sale.

Purchasers are solely responsible for the choice, selection and use of the ST products and services described herein, and ST assumes no liability whatsoever relating to the choice, selection or use of the ST products and services described herein.

No license, express or implied, by estoppel or otherwise, to any intellectual property rights is granted under this document. If any part of this document refers to any third party products or services it shall not be deemed a license grant by ST for the use of such third party products or services, or any intellectual property contained therein or considered as a warranty covering the use in any manner whatsoever of such third party products or services or any intellectual property contained therein.

**UNLESS OTHERWISE SET FORTH IN ST'S TERMS AND CONDITIONS OF SALE ST DISCLAIMS ANY EXPRESS OR IMPLIED WARRANTY WITH RESPECT TO THE USE AND/OR SALE OF ST PRODUCTS INCLUDING WITHOUT LIMITATION IMPLIED WARRANTIES OF MERCHANTABILITY, FITNESS FOR A PARTICULAR PURPOSE (AND THEIR EQUIVALENTS UNDER THE LAWS OF ANY JURISDICTION), OR INFRINGEMENT OF ANY PATENT, COPYRIGHT OR OTHER INTELLECTUAL PROPERTY RIGHT.**

**UNLESS EXPRESSLY APPROVED IN WRITING BY AN AUTHORIZED ST REPRESENTATIVE, ST PRODUCTS ARE NOT RECOMMENDED, AUTHORIZED OR WARRANTED FOR USE IN MILITARY, AIR CRAFT, SPACE, LIFE SAVING, OR LIFE SUSTAINING APPLICATIONS, NOR IN PRODUCTS OR SYSTEMS WHERE FAILURE OR MALFUNCTION MAY RESULT IN PERSONAL INJURY, DEATH, OR SEVERE PROPERTY OR ENVIRONMENTAL DAMAGE. ST PRODUCTS WHICH ARE NOT SPECIFIED AS "AUTOMOTIVE GRADE" MAY ONLY BE USED IN AUTOMOTIVE APPLICATIONS AT USER'S OWN RISK.**

Resale of ST products with provisions different from the statements and/or technical features set forth in this document shall immediately void any warranty granted by ST for the ST product or service described herein and shall not create or extend in any manner whatsoever, any liability of ST.

ST and the ST logo are trademarks or registered trademarks of ST in various countries.

Information in this document supersedes and replaces all information previously supplied.

The ST logo is a registered trademark of STMicroelectronics. All other names are the property of their respective owners.

© 2006 STMicroelectronics - All rights reserved

STMicroelectronics group of companies

Australia - Belgium - Brazil - Canada - China - Czech Republic - Finland - France - Germany - Hong Kong - India - Israel - Italy - Japan - Malaysia - Malta - Morocco - Singapore - Spain - Sweden - Switzerland - United Kingdom - United States of America

[www.st.com](http://www.st.com)