



24-Bit Analog-to-Digital Converters for Temperature Sensors

FEATURES

- 24 Bits, No Missing Codes
- Data Output Rates Up to 2kSPS
- Single-Cycle Settling for All Data Rates
- Simultaneous 50/60Hz Rejection at 20SPS
- 4 Differential/7 Single-Ended Inputs (ADS1248)
- 2 Differential/3 Single-Ended Inputs (ADS1247)
- Low-Noise PGA: 48nV at PGA = 128
- Matched Current Source DACs
- Very Low Drift Internal Voltage Reference: 10ppm/°C (max)
- Sensor Burnout Detection
- 4/8 General-Purpose I/Os (ADS1247/48)
- Internal Temperature Sensor
- Power Supply and V_{REF} Monitoring
- Self and System Calibration
- SPI™-Compatible Serial Interface
- Unipolar (+3.3V to +5V)/Bipolar ($\pm 2.5V$) Operation
- Digital Supply: +3.3V or +5V
- Operating Temperature $-40^{\circ}C$ to $+125^{\circ}C$

APPLICATIONS

- Temperature Measurement
 - RTDs, Thermocouples, and Thermistors
- Pressure Measurement
- Industrial Process Control

DESCRIPTION

The ADS1246, ADS1247, and ADS1248 are highly-integrated, precision, 24-bit analog-to-digital converters (ADCs). The ADS1246/7/8 feature an onboard, low-noise, programmable gain amplifier (PGA), a precision delta-sigma ADC with a single-cycle settling digital filter, and an internal oscillator. The ADS1247 and ADS1248 also provide a built-in, very low drift voltage reference with 10mA output capacity, and two matched programmable current digital-to-analog converters (DACs). The ADS1246/7/8 provide a complete front-end solution for temperature/bridge sensor applications including thermal couples, thermistors, RTDs, and strain-gauge applications.

An input multiplexer supports four differential inputs for the ADS1248, two for the ADS1247, and one for the ADS1246. In addition, the multiplexer has a sensor burnout detect, voltage bias for thermocouples, system monitoring, and general-purpose digital I/Os (ADS1247 and ADS1248). The onboard, low-noise PGA provides selectable gains of 1 to 128. The delta-sigma modulator and programmable digital filter settle in only one cycle, for fast channel cycling when using the input multiplexer, and support data rates up to 2kSPS. For data rates of 20SPS or less, both 50Hz and 60Hz interference are rejected by the filter.

The ADS1246 is offered in a small TSSOP-16 package, the ADS1247 is available in a TSSOP-20 package, and the ADS1248 in a TSSOP-28 package. All three devices are specified over the extended temperature range of $-40^{\circ}C$ to $+105^{\circ}C$.

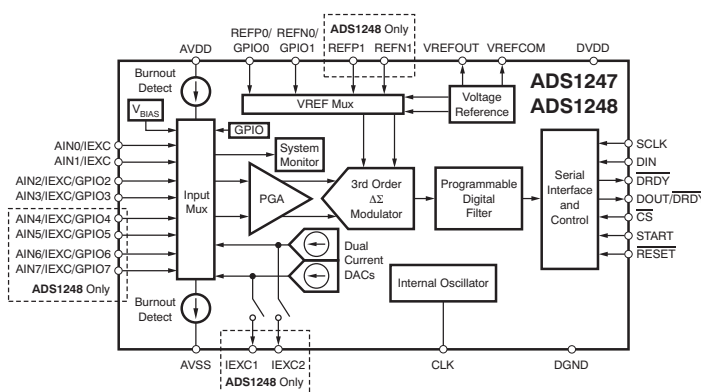
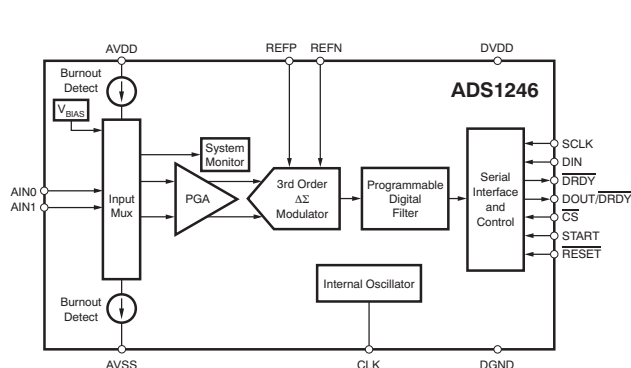

Please be aware that an important notice concerning availability, standard warranty, and use in critical applications of Texas Instruments semiconductor products and disclaimers thereto appears at the end of this data sheet.

SPI is a trademark of Motorola, Inc.

All other trademarks are the property of their respective owners.



This integrated circuit can be damaged by ESD. Texas Instruments recommends that all integrated circuits be handled with appropriate precautions. Failure to observe proper handling and installation procedures can cause damage.

ESD damage can range from subtle performance degradation to complete device failure. Precision integrated circuits may be more susceptible to damage because very small parametric changes could cause the device not to meet its published specifications.

PACKAGE/ORDERING INFORMATION⁽¹⁾

| PRODUCT | NUMBER OF INPUTS | VOLTAGE REFERENCE | DUAL SENSOR EXCITATION CURRENT SOURCES | PACKAGE-LEAD |
|---------|--|----------------------|--|--------------|
| ADS1246 | 1 Differential or 1 Single-Ended | External | NO | TSSOP-16 |
| ADS1247 | 2 Differential or 3 Single-Ended | Internal or External | YES | TSSOP-20 |
| ADS1248 | 4 Differential or 7 Single-Ended | Internal or External | YES | TSSOP-28 |

(1) For the most current package and ordering information, see the Package Option Addendum at the end of this data sheet, or see the TI website at www.ti.com

ABSOLUTE MAXIMUM RATINGS⁽¹⁾

Over operating free-air temperature range (unless otherwise noted).

| PARAMETER | ADS1246, ADS1247, ADS1248 | UNIT |
|-------------------------------|---------------------------|------|
| AVDD to AVSS | –0.3 to +5.5 | V |
| AVSS to DGND | –2.8 to +0.3 | V |
| DVDD to DGND | –0.3 to +5.5 | V |
| Input current | 100, momentary | mA |
| | 10, continuous | mA |
| Analog input voltage to AVSS | AVSS – 0.3 to AVDD + 0.3 | V |
| Digital input voltage to DGND | –0.3 to DVDD + 0.3 | V |
| Maximum junction temperature | +150 | °C |
| Operating temperature range | –40 to +125 | °C |
| Storage temperature range | –60 to +150 | °C |

(1) Stresses beyond those listed under *Absolute Maximum Ratings* may cause permanent damage to the device. These are stress ratings only, and functional operation of the device at these or any other conditions beyond those indicated is not implied. Exposure to absolute-maximum-rated conditions for extended periods may affect device reliability.

ELECTRICAL CHARACTERISTICS

All specifications at $T_A = -40^{\circ}\text{C}$ to $+105^{\circ}\text{C}$, $AVDD = +5\text{V}$, $DVDD = +3.3\text{V}$, $AVSS = DVSS = 0\text{V}$, and $V_{REF} = +2.048\text{V}$, unless otherwise noted.

| PARAMETER | CONDITIONS | ADS1246, ADS1247, ADS1248 | | | UNIT | |
|--|---|--|--|-------|-------------------------|-------------------------|
| | | MIN | TYP | MAX | | |
| ANALOG INPUTS | | | | | | |
| Full-scale input voltage ($V_{IN} = \text{ADCINP} - \text{ADCINN}$) | | $\pm V_{REF}/PGA$ | | | V | |
| Common-mode input range | | $AVSS + 0.1\text{V} + \frac{(V_{IN})(\text{Gain})}{2}$ | $AVDD - 0.1\text{V} - \frac{(V_{IN})(\text{Gain})}{2}$ | | V | |
| Differential input current | | 100 | | | pA | |
| PGA gain settings | | 1, 2, 4, 8, 16, 32, 64, 128 | | | | |
| Burnout current source | | 0.5, 2, or 10 | | | μA | |
| Bias voltage | | $(AVDD + AVSS)/2$ | | | V | |
| Bias voltage output impedance | | 400 | | | Ω | |
| SYSTEM PERFORMANCE | | | | | | |
| Resolution | No missing codes | 24 | | | Bits | |
| Data rate | | 5, 10, 20, 40, 80, 160, 320, 640, 1000, 2000 | | | SPS | |
| Integral nonlinearity (INL) | Differential input, best fit, PGA = 1 | 6 | | | 15 | ppm |
| Offset error | After calibration | -15 | | | 15 | μV |
| Offset drift | | see Figure 8 to Figure 11 | | | nV/ $^{\circ}\text{C}$ | |
| Gain error | All PGAs, data rate = 40, 80, or 160SPS | -0.02 | ± 0.005 | 0.02 | % | |
| Gain drift | PGA = 1 | see Figure 12 to Figure 15 | | | ppm/ $^{\circ}\text{C}$ | |
| ADC conversion time | | Single-cycle settling | | | | |
| Noise | | See Table 5 to Table 8 | | | | |
| Normal-mode rejection | | See Table 10 | | | | |
| Common-mode rejection | At dc, PGA = 1 | 80 | 90 | | dB | |
| | At dc, PGA = 32 | 90 | 125 | | dB | |
| Power-supply rejection | AVDD, DVDD at dc | 100 | 135 | | dB | |
| VOLTAGE REFERENCE INPUT | | | | | | |
| Voltage reference input ($V_{REF} = V_{REFP} - V_{REFN}$) | | 0.5 | $(AVDD - AVSS) - 1$ | | V | |
| Negative reference input (REFN) | | $AVSS - 0.1$ | $REFP - 0.5$ | | V | |
| Positive reference input (REFP) | | $REFN + 0.5$ | $AVDD + 0.1$ | | V | |
| Reference input current | | 30 | | | nA | |
| ON-CHIP VOLTAGE REFERENCE | | | | | | |
| Output voltage | | 2.038 | 2.048 | 2.058 | V | |
| Output current ⁽¹⁾ | | ± 10 | | | mA | |
| Load regulation | | 50 | | | $\mu\text{V}/\text{mA}$ | |
| Drift ⁽²⁾ | $T_A = +25^{\circ}\text{C}$ to $+105^{\circ}\text{C}$ | 2 | | | 10 | ppm/ $^{\circ}\text{C}$ |
| | $T_A = -40^{\circ}\text{C}$ to $+105^{\circ}\text{C}$ | 6 | | | 15 | ppm/ $^{\circ}\text{C}$ |
| Startup time | | See Table 11 | | | μs | |
| Quiescent current | Additional AVDD current | 180 | | | μA | |

- (1) Do not exceed this loading on the internal voltage reference.
 (2) Specified by the combination of design and final production test.

ELECTRICAL CHARACTERISTICS (continued)

All specifications at $T_A = -40^{\circ}\text{C}$ to $+105^{\circ}\text{C}$, $\text{AVDD} = +5\text{V}$, $\text{DVDD} = +3.3\text{V}$, $\text{AVSS} = \text{DVSS} = 0\text{V}$, and $V_{\text{REF}} = +2.048\text{V}$, unless otherwise noted.

| PARAMETER | | CONDITIONS | ADS1246, ADS1247, ADS1248 | | | UNIT |
|---|--|---|------------------------------------|-----------|----------------------|--------------------------------|
| | | | MIN | TYP | MAX | |
| CURRENT SOURCES (IDACS) | | | | | | |
| Output current | | | 50, 100, 250, 500, 750, 1000, 1500 | | | μA |
| Voltage compliance | | All currents | $\text{AVDD} - 0.7$ | | | V |
| Initial error | | All currents, each IDAC | -6 | ± 1.0 | 6 | % of FS |
| Initial mismatch | | All currents, between IDACs | ± 0.03 | | | % of FS |
| Temperature drift | | Each IDAC | 200 | | | $\text{ppm}/^{\circ}\text{C}$ |
| Temperature drift matching | | Between IDACs | 10 | | | $\text{ppm}/^{\circ}\text{C}$ |
| SYSTEM MONITORS | | | | | | |
| Temperature sensor reading | Voltage | $T_A = +25^{\circ}\text{C}$ | 112 | | | mV |
| | Drift | | 379 | | | $\mu\text{V}/^{\circ}\text{C}$ |
| GENERAL-PURPOSE INPUT/OUTPUT (GPIO) | | | | | | |
| Logic levels | V_{IH} | | 0.7AVDD | | AVDD | V |
| | V_{IL} | | AVSS | | 0.3AVDD | V |
| | V_{OH} | $I_{\text{OH}} = 1\text{mA}$ | 0.8AVDD | | | V |
| | V_{OL} | $I_{\text{OL}} = 1\text{mA}$ | | | 0.2AVDD | V |
| DIGITAL INPUT/OUTPUT (other than GPIO) | | | | | | |
| Logic levels | V_{IH} | | 0.7DVDD | | DVDD | V |
| | V_{IL} | | DGND | | 0.3DVDD | V |
| | V_{OH} | $I_{\text{OH}} = 1\text{mA}$ | 0.8DVDD | | | V |
| | V_{OL} | $I_{\text{OL}} = 1\text{mA}$ | DGND | | 0.2DVDD | V |
| Input leakage | | $\text{DGND} < V_{\text{IN}} < \text{DVDD}$ | | | ± 10 | μA |
| Clock input (CLK) | Frequency | | 1 | | 4.5 | MHz |
| | Duty cycle | | 25 | | 75 | % |
| Internal oscillator frequency | | | 3.89 | 4.096 | 4.3 | MHz |
| POWER SUPPLY | | | | | | |
| DVDD | | | 3.234 | | 5.25 | V |
| AVSS | | | -2.5 | | 0 | V |
| AVDD | | | $\text{AVSS} + 3.234$ | | $\text{AVSS} + 5.25$ | V |
| DVDD current | Normal mode, $\text{DVDD} = 5\text{V}$, data rate = 80SPS, internal oscillator | | | 230 | | μA |
| | Normal mode, $\text{DVDD} = 3.3\text{V}$, data rate = 20SPS, internal oscillator | | | 210 | | μA |
| | Sleep mode | | | 0.2 | | μA |
| AVDD current | Converting, $\text{AVDD} = 5\text{V}$, data rate = 80SPS, internal oscillator | | | 350 | | μA |
| | Converting, $\text{AVDD} = 3.3\text{V}$, data rate = 20SPS, internal oscillator | | | 212 | | μA |
| | Sleep mode | | | 0.1 | | μA |
| Power dissipation | $\text{AVDD} = \text{DVDD} = 5\text{V}$, data rate = 80SPS, internal oscillator | | | 2.9 | | mW |
| | $\text{AVDD} = \text{DVDD} = 3.3\text{V}$, data rate = 20SPS, internal oscillator | | | 1.2 | | mW |
| TEMPERATURE RANGE | | | | | | |
| Specified | | | -40 | | +105 | $^{\circ}\text{C}$ |
| Operating | | | -40 | | +125 | $^{\circ}\text{C}$ |
| Storage | | | -60 | | +150 | $^{\circ}\text{C}$ |

PIN CONFIGURATIONS

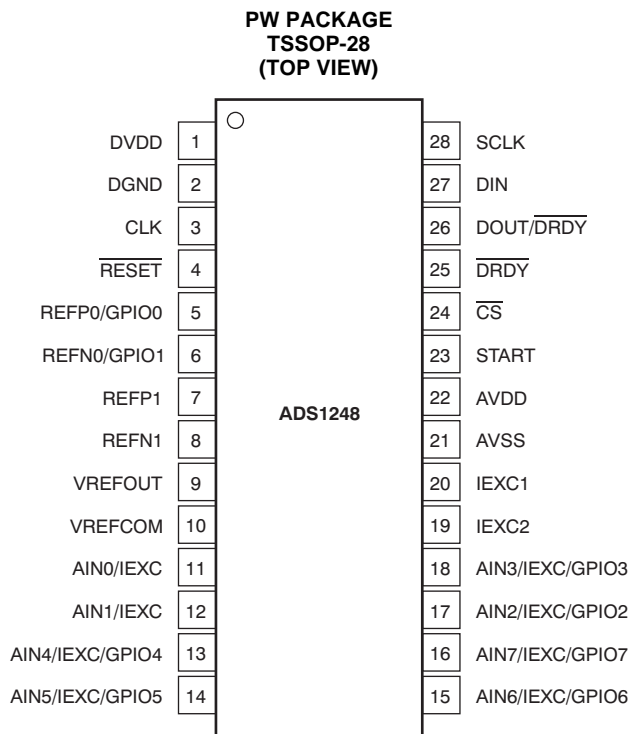

ADS1248 (TSSOP-28) PIN DESCRIPTIONS

| NAME | PIN NO. | ANALOG/DIGITAL INPUT/OUTPUT | DESCRIPTION |
|---------------------------|---------|--------------------------------|--|
| DVDD | 1 | Digital | Digital Power Supply |
| DGND | 2 | Digital | Digital Ground |
| CLK | 3 | Digital Input | External Clock Input. Tie this pin to DGND to activate the internal oscillator. |
| $\overline{\text{RESET}}$ | 4 | Digital Input | Chip Reset (active low). Returns all register values to reset values. |
| REFP0/GPIO0 | 5 | Analog Input Digital In/Out | Positive External Reference Input 0, or General-Purpose Digital Input/Output Pin 0 |
| REFN0/GPIO1 | 6 | Analog Input Digital In/Out | Negative External Reference 0 Input, or General-Purpose Digital Input/Output Pin 1 |
| REFP1 | 7 | Analog Input | Positive External Reference 1 Input |
| REFN1 | 8 | Analog Input | Negative External Reference 1 Input |
| VREFOUT | 9 | Analog Output | Positive Internal Reference Voltage Output |
| VREFCOM | 10 | Analog Output | Negative Internal Reference Voltage Output. Connect this pin to AVSS when using a unipolar supply, or to the midvoltage of the power supply when using a bipolar supply. |
| AIN0/IEXC | 11 | Analog Input | Analog Input 0, optional Excitation Current Output |
| AIN1/IEXC | 12 | Analog Input | Analog Input 1, optional Excitation Current Output |
| AIN4/IEXC/GPIO4 | 13 | Analog Input Digital In/Out | Analog Input 4, optional Excitation Current Output, or General-Purpose Digital Input/Output Pin 4 |
| AIN5/IEXC/GPIO5 | 14 | Analog Input Digital In/Out | Analog Input 5, optional Excitation Current Output, or General-Purpose Digital Input/Output Pin 5 |
| AIN6/IEXC/GPIO6 | 15 | Analog Input Digital In/Out | Analog Input 6, optional Excitation Current Output, or General-Purpose Digital Input/Output Pin 6 |
| AIN7/IEXC/GPIO7 | 16 | Analog Input Digital In/Out | Analog Input 7, optional Excitation Current Output, or General-Purpose Digital Input/Output Pin 7 |
| AIN2/IEXC/GPIO2 | 17 | Analog Input Digital In/Out | Analog Input 2, optional Excitation Current Output, or General-Purpose Digital Input/Output Pin 2 |

ADS1248 (TSSOP-28) PIN DESCRIPTIONS (continued)

| NAME | PIN NO. | ANALOG/DIGITAL INPUT/OUTPUT | DESCRIPTION |
|-------------------------|---------|--------------------------------|---|
| AIN3/IEXC/GPIO3 | 18 | Analog Input Digital In/Out | Analog Input 3, optional Excitation Current Output, or General-Purpose Digital Input/Output Pin 3 |
| IOUT2 | 19 | Analog Output | Excitation Current Output 2 |
| IOUT1 | 20 | Analog Output | Excitation Current Output 1 |
| AVSS | 21 | Analog | Negative Analog Power Supply |
| AVDD | 22 | Analog | Positive Analog Power Supply |
| START | 23 | Digital Input | Conversion start. See text for complete description. |
| \overline{CS} | 24 | Digital Input | Chip Select (active low) |
| \overline{DRDY} | 25 | Digital Output | Data Ready (active low) |
| DOUT/ \overline{DRDY} | 26 | Digital Output | Serial Data Out Output, or Data Out combined with Data Ready (active low when \overline{DRDY} function enabled) |
| DIN | 27 | Digital Input | Serial Data Input |
| SCLK | 28 | Digital Input | Serial Clock Input |

**PW PACKAGE
TSSOP-20
(TOP VIEW)**

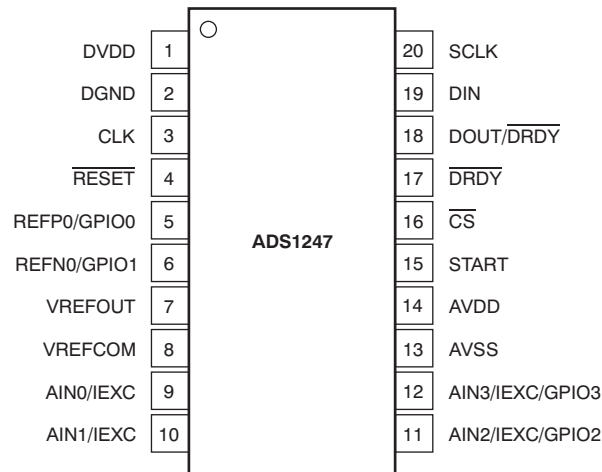

ADS1247 (TSSOP-20) PIN DESCRIPTIONS

| NAME | PIN NO. | ANALOG/DIGITAL INPUT/OUTPUT | DESCRIPTION |
|--------------------------------|---------|--------------------------------|--|
| DVDD | 1 | Digital | Digital Power Supply |
| DGND | 2 | Digital | Digital Ground |
| CLK | 3 | Digital Input | External Clock Input. Tie this pin to DGND to activate the internal oscillator. |
| $\overline{\text{RESET}}$ | 4 | Digital Input | Chip Reset (active low). Returns all register values to reset values. |
| REFP0/GPIO0 | 5 | Analog Input Digital In/Out | Positive External Reference Input, or General-Purpose Digital Input/Output Pin 0 |
| REFN0/GPIO1 | 6 | Analog Input Digital In/Out | Negative External Reference Input, or General-Purpose Digital Input/Output Pin 1 |
| VREFOUT | 7 | Analog Output | Positive Internal Reference Voltage Output |
| VREFCOM | 8 | Analog Output | Negative Internal Reference Voltage Output. Connect this pin to AVSS when using a unipolar supply, or to the midvoltage of the power supply when using a bipolar supply. |
| AIN0/IEXC | 9 | Analog Input | Analog Input 0, optional Excitation Current Output |
| AIN1/IEXC | 10 | Analog Input | Analog Input 1, optional Excitation Current Output |
| AIN2/IEXC/GPIO2 | 11 | Analog Input Digital In/Out | Analog Input 2, optional Excitation Current Output, or General-Purpose Digital Input/Output Pin 2 |
| AIN3/IEXC/GPIO3 | 12 | Analog Input Digital In/Out | Analog Input 3, with or without Excitation Current Output, or General-Purpose Digital Input/Output Pin 3 |
| AVSS | 13 | Analog | Negative Analog Power Supply |
| AVDD | 14 | Analog | Positive Analog Power Supply |
| START | 15 | Digital Input | Conversion Start. See text for description of use. |
| $\overline{\text{CS}}$ | 16 | Digital Input | Chip Select (active low) |
| $\overline{\text{DRDY}}$ | 17 | Digital Output | Data Ready (active low) |
| DOUT/ $\overline{\text{DRDY}}$ | 18 | Digital Output | Serial Data Out Output, or Data Out combined with Data Ready (active low when $\overline{\text{DRDY}}$ function enabled) |
| DIN | 19 | Digital Input | Serial Data Input |
| SCLK | 20 | Digital Input | Serial Clock Input |

**PW PACKAGE
TSSOP-16
(TOP VIEW)**

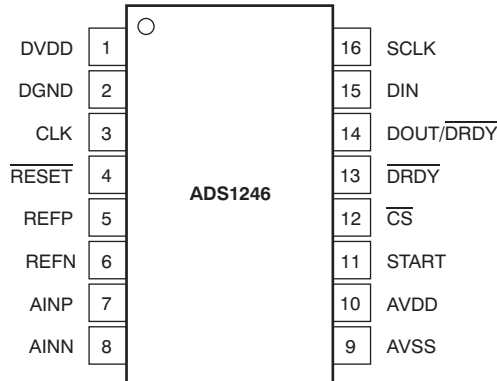

ADS1246 (TSSOP-16) PIN DESCRIPTIONS

| NAME | PIN NO. | ANALOG/DIGITAL INPUT/OUTPUT | DESCRIPTION |
|-----------|---------|-----------------------------|--|
| DVDD | 1 | Digital | Digital Power Supply |
| DGND | 2 | Digital | Digital Ground |
| CLK | 3 | Digital Input | External Clock Input. Tie this pin to DGND to activate the internal oscillator. |
| RESET | 4 | Digital Input | Chip Reset (active low). Returns all register values to reset values. |
| REFP | 5 | Analog Input | Positive External Reference Input |
| REFN | 6 | Analog Input | Negative External Reference Input |
| AINP | 7 | Analog Input | Positive Analog Input |
| AINN | 8 | Analog Input | Negative Analog Input |
| AVSS | 9 | Analog | Negative Analog Power Supply |
| AVDD | 10 | Analog | Positive Analog Power Supply |
| START | 11 | Digital Input | Conversion Start. See text for description of use. |
| CS | 12 | Digital Input | Chip Select (active low) |
| DRDY | 13 | Digital Output | Data Ready (active low) |
| DOUT/DRDY | 14 | Digital Output | Serial Data Out Output, or Data Out combined with Data Ready (active low when DRDY function enabled) |
| DIN | 15 | Digital Input | Serial Data Input |
| SCLK | 16 | Digital Input | Serial Clock Input |

TIMING DIAGRAMS

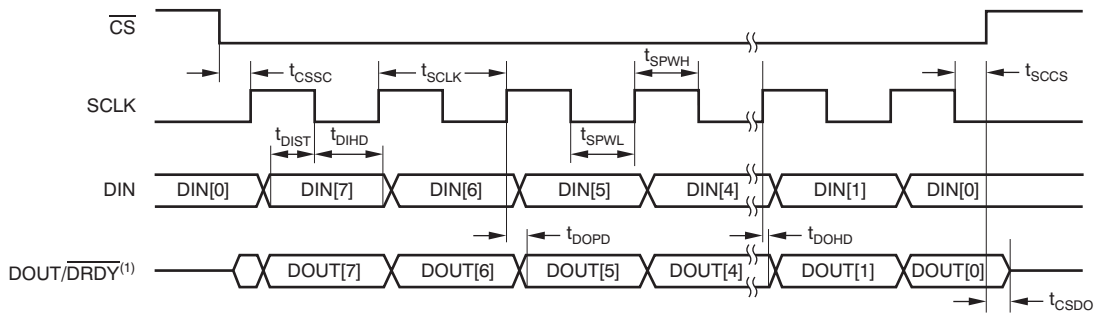

Figure 1. Serial Interface Timing

Table 1. Timing Characteristics for Figure 1⁽¹⁾

| SYMBOL | DESCRIPTION | MIN | MAX | UNIT |
|-------------------|--|------|------|---------------------------------|
| t _{CSSC} | \overline{CS} low to first SCLK high (set up time) | 10 | | ns |
| t _{SCCS} | SCLK low to \overline{CS} high (hold time) | 7 | | t _{OSC} ⁽²⁾ |
| t _{DIST} | DIN set up time | 5 | | ns |
| t _{DIHD} | DIN hold time | 5 | | ns |
| t _{DOPD} | SCLK rising edge to new data valid | | 30 | ns |
| t _{DOHD} | DOUT hold time | 0 | | ns |
| t _{SCLK} | SCLK period | 500 | | ns |
| | | | 64 | conversions |
| t _{SPWH} | SCLK pulse width high | 0.25 | 0.75 | t _{SCLK} |
| t _{SPWL} | SCLK pulse width low | 0.25 | 0.75 | t _{SCLK} |
| t _{CSDO} | \overline{CS} high to DOUT high impedance | | 10 | ns |

(1) DRDY MODE bit = 0.

(2) t_{OSC} = 1/f_{CLK}. The default clock frequency f_{CLK} = 4.096MHz. Expect a ±5% variation when the internal oscillator is used.

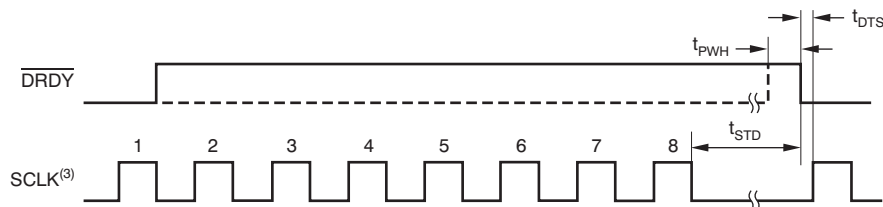

Figure 2. SPI Interface Timing to Allow Conversion Result Loading⁽³⁾⁽⁴⁾

Table 2. Timing Characteristics for Figure 2

| SYMBOL | DESCRIPTION | MIN | MAX | UNIT |
|------------------|--|-----|-----|------------------|
| t _{PWH} | \overline{DRDY} pulse width high | 3 | | t _{OSC} |
| t _{STD} | SCLK low prior to \overline{DRDY} low | 5 | | t _{OSC} |
| t _{DTS} | \overline{DRDY} falling edge to SCLK rising edge | 30 | | ns |

(3) This timing diagram is applicable only when the \overline{CS} pin is low. SCLK need not be low during t_{STD} when \overline{CS} is high.

(4) SCLK should only be sent in multiples of eight during partial retrieval of output data.

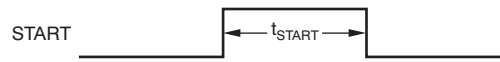

Figure 3. Minimum START Pulse Width

Table 3. Timing Characteristics for Figure 3

| SYMBOL | DESCRIPTION | MIN | MAX | UNIT |
|-------------|------------------------|-----|-----|-----------|
| t_{START} | START pulse width high | 3 | | t_{OSC} |

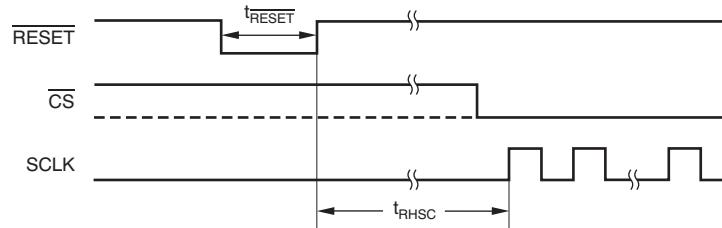

Figure 4. Reset Pulse Width and SPI Communication After Reset

Table 4. Timing Characteristics for Figure 4

| SYMBOL | DESCRIPTION | MIN | MAX | UNIT |
|-------------|--|--------------------|-----|-----------|
| t_{RESET} | \overline{RESET} pulse width low | 4 | | t_{OSC} |
| t_{RHSC} | \overline{RESET} high to SPI communication start | 0.6 ⁽¹⁾ | | ms |

(1) Applicable only when $f_{OSC} = 4.096\text{MHz}$ and scales proportionately with f_{OSC} frequency.

NOISE PERFORMANCE

Table 5. Noise in μV , rms and (μV , peak-to-peak) at $\text{AVDD} = \text{DVDD} = 5\text{V}$, $\text{AVSS} = \text{DGND} = 0\text{V}$, Using Internal Reference (2.048V)

| DATA RATE (SPS) | PGA SETTING | | | | | | | |
|-----------------|----------------|----------------|--------------|--------------|--------------|--------------|--------------|-------------|
| | 1 | 2 | 4 | 8 | 16 | 32 | 64 | 128 |
| 5 | 1.79 (8.10) | 0.76 (3.90) | 0.40 (2.00) | 0.23 (1.05) | 0.12 (0.63) | 0.08 (0.39) | 0.07 (0.34) | 0.06 (0.32) |
| 10 | 2.46 (13.80) | 1.04 (5.50) | 0.56 (2.75) | 0.31 (1.75) | 0.14 (0.78) | 0.10 (0.46) | 0.09 (0.52) | 0.08 (0.43) |
| 20 | 3.20 (14.00) | 1.53 (8.00) | 0.85 (5.00) | 0.45 (2.80) | 0.25 (1.17) | 0.16 (0.73) | 0.12 (0.56) | 0.11 (0.63) |
| 40 | 3.30 (18.00) | 1.50 (7.80) | 0.86 (4.84) | 0.40 (2.16) | 0.30 (1.75) | 0.20 (1.25) | 0.17 (0.87) | 0.16 (0.85) |
| 80 | 4.60 (27.10) | 2.23 (14.00) | 1.00 (4.80) | 0.64 (3.25) | 0.38 (2.40) | 0.29 (1.82) | 0.27 (1.69) | 0.23 (1.30) |
| 160 | 7.00 (42.00) | 3.30 (20.00) | 1.52 (9.25) | 0.83 (5.10) | 0.55 (3.14) | 0.41 (3.00) | 0.35 (2.14) | 0.34 (2.40) |
| 320 | 10.60 (67.00) | 5.60 (40.00) | 2.90 (17.50) | 1.47 (8.70) | 0.85 (5.14) | 0.59 (4.03) | 0.49 (3.10) | 0.48 (3.10) |
| 640 | 15.80 (101.00) | 8.30 (52.00) | 4.20 (24.80) | 2.14 (15.50) | 1.23 (8.25) | 0.82 (5.21) | 0.67 (4.55) | 0.66 (4.30) |
| 1000 | 38.00 (420.00) | 19.70 (190.00) | 8.80 (67.50) | 4.50 (40.30) | 2.64 (24.80) | 1.47 (14.34) | 0.96 (6.23) | 0.83 (5.30) |
| 2000 | 40.80 (449.00) | 18.40 (179.00) | 9.30 (87.00) | 4.80 (43.50) | 2.56 (22.60) | 1.63 (11.90) | 1.32 (10.60) | 1.23 (7.40) |

Table 6. Effective Number of Bits, rms and (peak-to-peak) Noise Using the Internal Reference (+2.048V)⁽¹⁾

| DATA RATE (SPS) | PGA SETTING | | | | | | | |
|-----------------|---------------|---------------|---------------|---------------|---------------|---------------|---------------|---------------|
| | 1 | 2 | 4 | 8 | 16 | 32 | 64 | 128 |
| 5 | 21.50 (19.10) | 21.60 (19.30) | 21.60 (19.20) | 21.40 (19.20) | 21.30 (19.00) | 20.90 (18.60) | 20.10 (17.80) | 19.20 (17.00) |
| 10 | 21.00 (18.50) | 21.20 (18.80) | 21.10 (18.80) | 21.00 (18.40) | 20.90 (18.40) | 20.50 (18.10) | 19.70 (17.40) | 18.70 (16.60) |
| 20 | 20.60 (18.40) | 20.60 (18.20) | 20.50 (17.90) | 20.40 (17.80) | 20.30 (17.80) | 20.00 (17.50) | 19.20 (16.60) | 18.20 (16.00) |
| 40 | 20.50 (18.10) | 20.70 (18.30) | 20.50 (18.00) | 20.60 (18.10) | 20.10 (17.90) | 19.60 (17.30) | 18.90 (16.50) | 17.80 (15.40) |
| 80 | 20.10 (17.50) | 20.10 (17.40) | 20.30 (18.00) | 19.90 (17.60) | 19.70 (17.40) | 19.20 (16.40) | 18.30 (16.00) | 17.40 (15.20) |
| 160 | 19.40 (16.90) | 19.60 (17.00) | 19.60 (17.10) | 19.50 (16.90) | 19.40 (16.60) | 18.70 (16.30) | 17.80 (15.20) | 16.80 (14.50) |
| 320 | 18.90 (16.20) | 18.80 (16.00) | 18.70 (16.10) | 18.70 (16.20) | 18.50 (16.10) | 18.00 (15.60) | 17.30 (14.80) | 16.40 (13.80) |
| 640 | 18.30 (15.60) | 18.20 (15.60) | 18.20 (17.50) | 18.20 (15.30) | 18.00 (15.30) | 17.60 (15.20) | 16.70 (14.10) | 15.90 (13.20) |
| 1000 | 17.00 (13.50) | 16.90 (13.70) | 17.10 (14.20) | 17.10 (13.90) | 16.90 (13.80) | 16.80 (13.50) | 16.30 (13.60) | 15.50 (12.70) |
| 2000 | 16.90 (13.40) | 17.10 (13.80) | 17.00 (13.80) | 17.00 (13.80) | 16.80 (13.40) | 16.50 (13.70) | 15.90 (13.20) | 14.90 (12.20) |

$$(1) \text{ Effective Number of Bits} = \frac{\ln(\text{FSR/Noise})}{\ln(2)}$$

Table 7. Noise in μV , rms and (μV , peak-to-peak) at $\text{AVDD} = \text{DVDD} = 5\text{V}$, $\text{AVSS} = \text{DGND} = 0\text{V}$, Using External Reference (2.5V)

| DATA RATE (SPS) | PGA SETTING | | | | | | | |
|-----------------|----------------|----------------|----------------|--------------|--------------|--------------|-------------|-------------|
| | 1 | 2 | 4 | 8 | 16 | 32 | 64 | 128 |
| 5 | 1.22 (5.50) | 0.75 (4.20) | 0.41 (2.10) | 0.21 (1.10) | 0.11 (0.48) | 0.07 (0.34) | 0.06 (0.3) | 0.05 (0.23) |
| 10 | 1.67 (9.83) | 0.89 (4.02) | 0.55 (2.98) | 0.30 (1.07) | 0.16 (0.73) | 0.09 (0.54) | 0.07 (0.39) | 0.07 (0.37) |
| 20 | 2.55 (14.90) | 1.33 (7.45) | 0.77 (4.25) | 0.37 (2.09) | 0.20 (1.10) | 0.13 (0.77) | 0.11 (0.57) | 0.10 (0.59) |
| 40 | 3.03 (19.07) | 1.46 (8.49) | 0.75 (4.25) | 0.41 (2.46) | 0.24 (1.27) | 0.15 (0.84) | 0.16 (0.86) | 0.15 (0.83) |
| 80 | 3.95 (24.73) | 2.04 (13.56) | 0.88 (5.74) | 0.54 (3.80) | 0.33 (2.16) | 0.21 (1.35) | 0.21 (1.28) | 0.19 (1.18) |
| 160 | 5.71 (45.59) | 2.80 (19.52) | 1.43 (10.06) | 0.74 (5.70) | 0.45 (3.20) | 0.29 (2.11) | 0.29 (1.90) | 0.28 (1.89) |
| 320 | 10.41 (82.84) | 5.18 (43.06) | 2.97 (21.15) | 1.35 (10.91) | 0.76 (5.70) | 0.50 (3.39) | 0.41 (3.02) | 0.39 (2.67) |
| 640 | 14.58 (130.50) | 7.52 (64.21) | 4.01 (31.71) | 1.68 (11.74) | 1.05 (9.58) | 0.70 (5.39) | 0.58 (4.07) | 0.54 (3.92) |
| 1000 | 35.52 (481.70) | 17.64 (206.40) | 12.77 (102.00) | 5.11 (41.60) | 2.21 (25.67) | 1.26 (13.53) | 0.84 (8.03) | 0.71 (5.48) |
| 2000 | 35.42 (415.20) | 17.41 (199.60) | 8.76 (101.00) | 4.51 (50.54) | 2.43 (26.18) | 1.51 (13.60) | 1.18 (8.78) | 1.08 (7.52) |

Table 8. Effective Number of Bits, rms and (peak-to-peak) Noise Using External Reference (+2.5V)⁽¹⁾

| DATA RATE (SPS) | PGA SETTING | | | | | | | |
|-----------------|---------------|---------------|---------------|---------------|---------------|---------------|---------------|---------------|
| | 1 | 2 | 4 | 8 | 16 | 32 | 64 | 128 |
| 5 | 22.00 (19.80) | 21.70 (19.20) | 21.60 (19.20) | 21.50 (19.20) | 21.40 (19.30) | 21.00 (18.80) | 20.30 (18.00) | 19.60 (17.40) |
| 10 | 21.50 (19.00) | 21.40 (19.20) | 21.10 (18.70) | 21.00 (18.30) | 20.90 (18.70) | 20.80 (18.10) | 20.10 (17.60) | 19.00 (16.70) |
| 20 | 20.90 (18.40) | 20.80 (18.40) | 20.60 (18.20) | 20.70 (18.20) | 20.60 (18.10) | 20.20 (17.60) | 19.50 (17.10) | 18.60 (16.00) |
| 40 | 20.70 (18.00) | 20.70 (18.20) | 20.70 (18.20) | 20.50 (18.00) | 20.30 (17.90) | 20.00 (17.50) | 18.90 (16.50) | 18.00 (15.50) |
| 80 | 20.30 (17.60) | 20.20 (17.50) | 20.40 (17.70) | 20.10 (17.30) | 19.90 (17.10) | 19.50 (16.80) | 18.50 (15.90) | 17.60 (15.00) |
| 160 | 19.70 (16.70) | 19.80 (17.00) | 19.70 (16.90) | 19.70 (16.70) | 19.40 (16.60) | 19.10 (16.20) | 18.00 (15.30) | 17.00 (14.30) |
| 320 | 18.90 (15.90) | 18.90 (15.80) | 18.70 (15.90) | 18.80 (15.80) | 18.70 (15.70) | 18.30 (15.50) | 17.50 (14.70) | 16.60 (13.80) |
| 640 | 18.40 (15.20) | 18.30 (15.20) | 18.30 (15.30) | 18.50 (15.70) | 18.20 (15.00) | 17.80 (14.80) | 17.00 (14.20) | 16.10 (13.30) |
| 1000 | 17.10 (13.30) | 17.10 (13.60) | 16.60 (13.60) | 16.90 (13.90) | 17.10 (13.60) | 16.90 (13.50) | 16.50 (13.20) | 15.80 (12.80) |
| 2000 | 17.10 (13.60) | 17.10 (13.60) | 17.10 (13.60) | 17.10 (13.60) | 17.00 (13.50) | 16.70 (13.50) | 16.00 (13.10) | 15.10 (12.30) |

$$(1) \text{ Effective Number of Bits} = \frac{\ln(\text{FSR/Noise})}{\ln(2)}$$

TYPICAL CHARACTERISTICS

At $T_A = +25^\circ\text{C}$, $AVDD = DVDD = 5\text{V}$, $V_{REF} = 2.5\text{V}$, and $AVSS = DVSS = 0\text{V}$, unless otherwise noted.

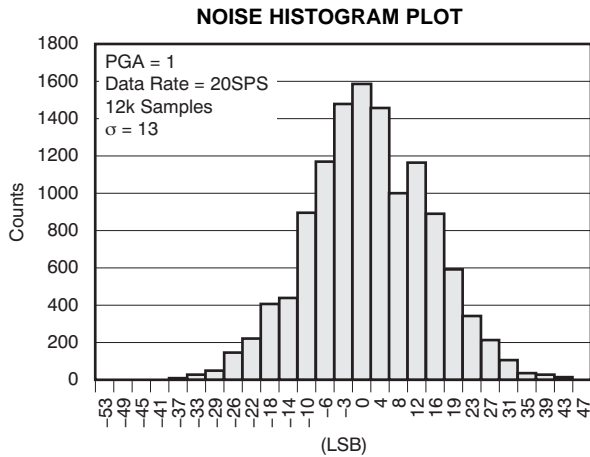

Figure 5.

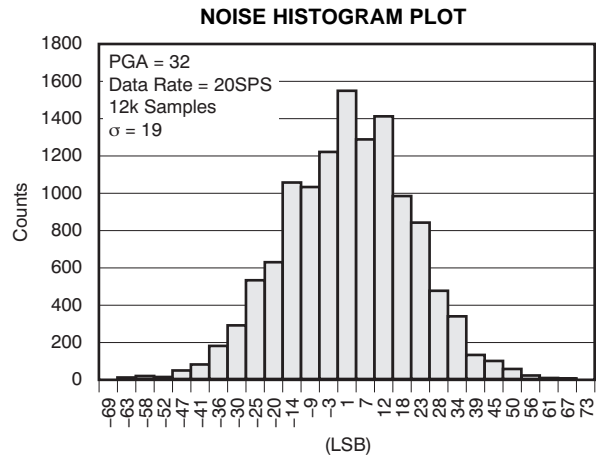

Figure 6.

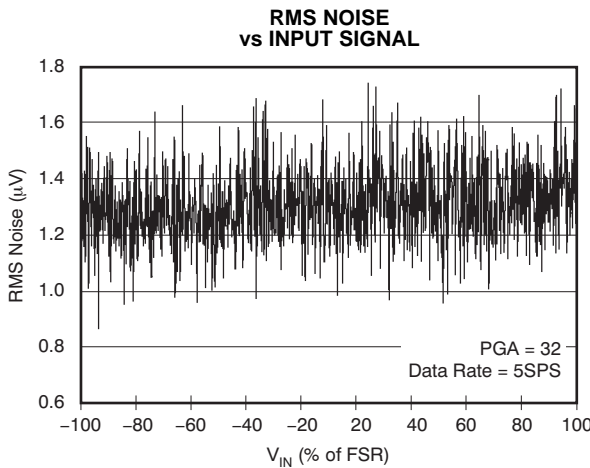

Figure 7.

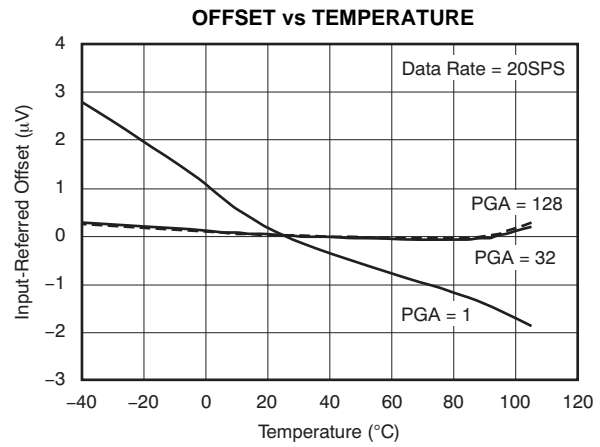

Figure 8.

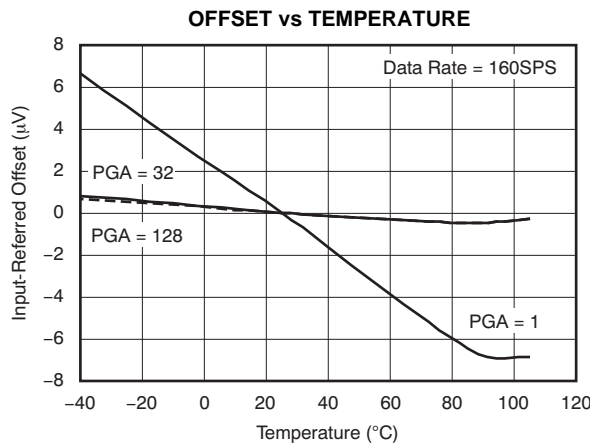

Figure 9.

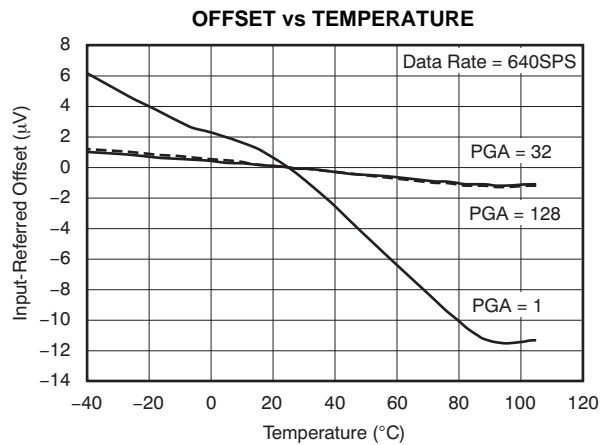

Figure 10.

TYPICAL CHARACTERISTICS (continued)

At $T_A = +25^\circ\text{C}$, $AVDD = DVDD = 5\text{V}$, $V_{REF} = 2.5\text{V}$, and $AVSS = DVSS = 0\text{V}$, unless otherwise noted.

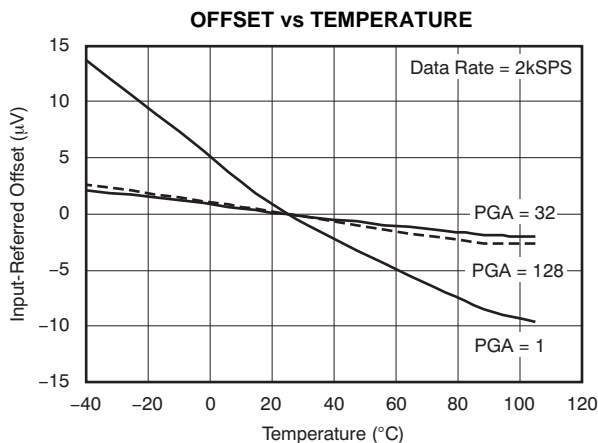

Figure 11.

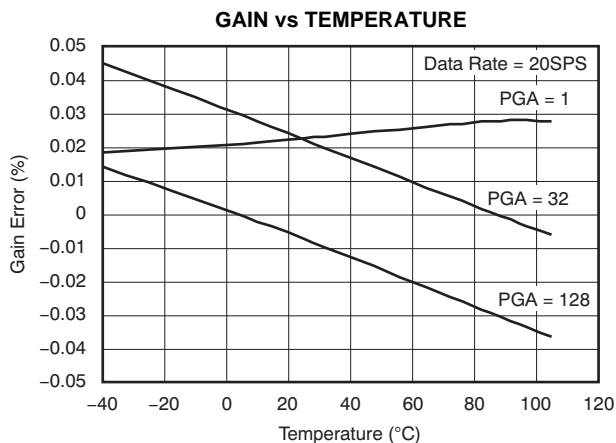

Figure 12.

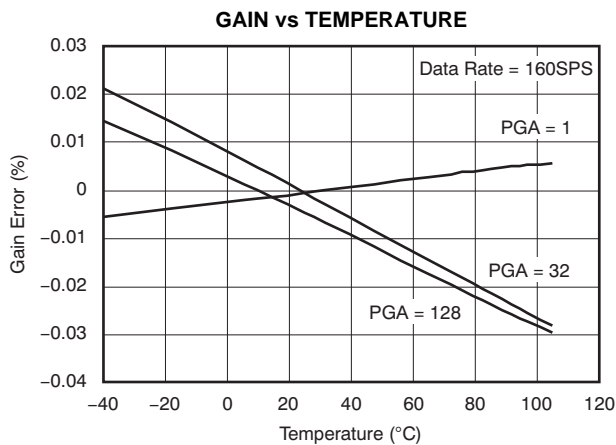

Figure 13.

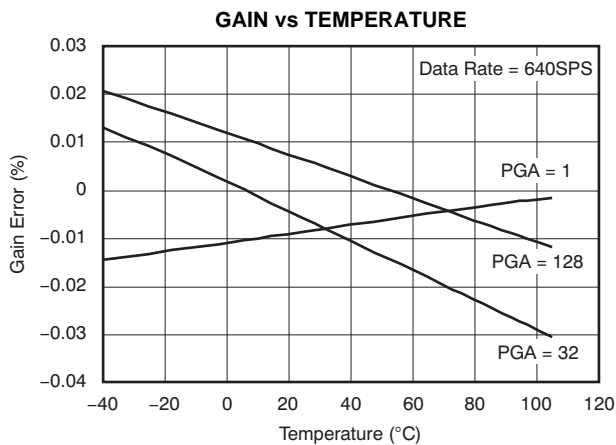

Figure 14.

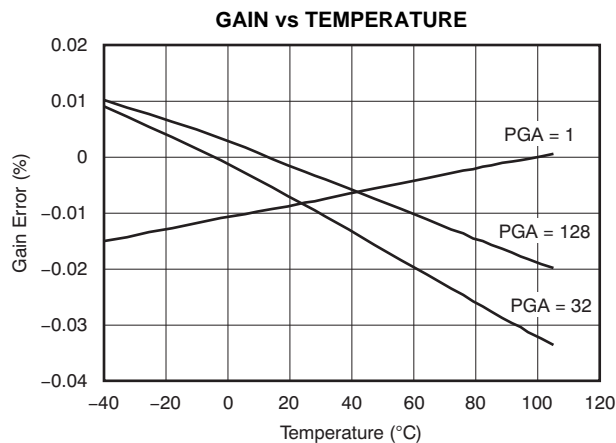

Figure 15.

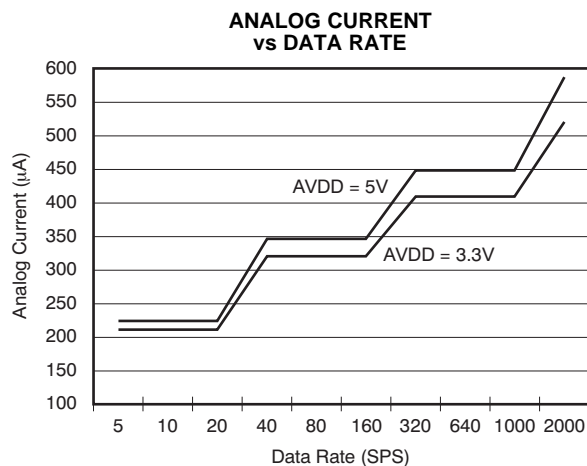

Figure 16.

TYPICAL CHARACTERISTICS (continued)

At $T_A = +25^\circ\text{C}$, $AVDD = DVDD = 5\text{V}$, $V_{REF} = 2.5\text{V}$, and $AVSS = DVSS = 0\text{V}$, unless otherwise noted.

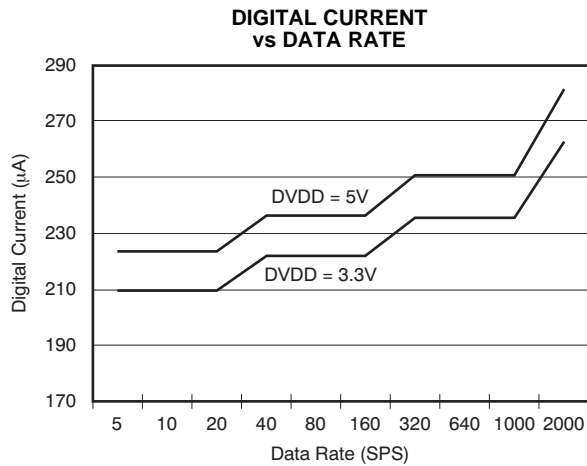

Figure 17.

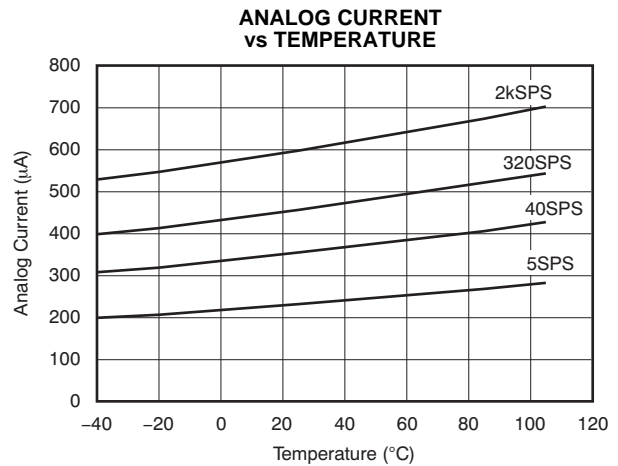

Figure 18.

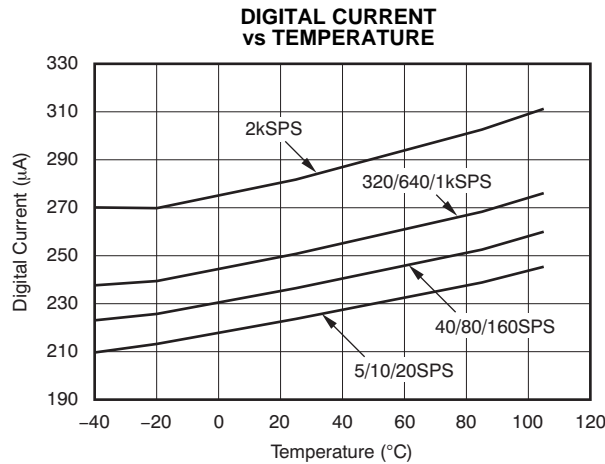

Figure 19.

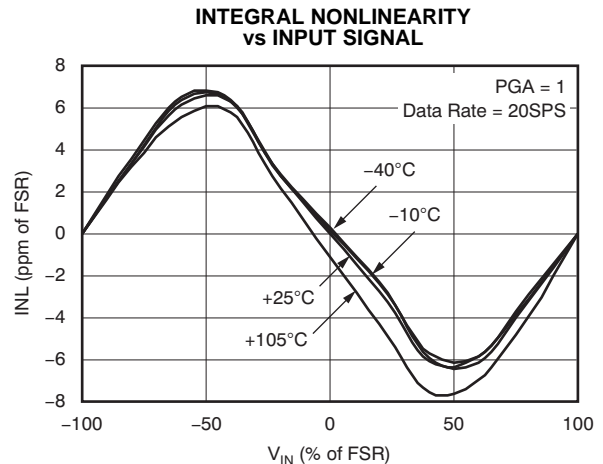

Figure 20.

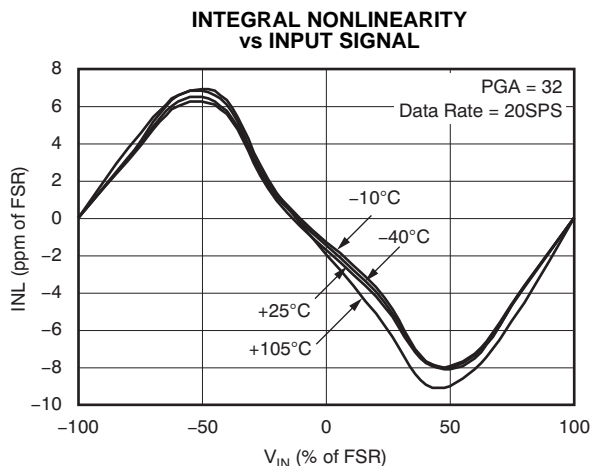

Figure 21.

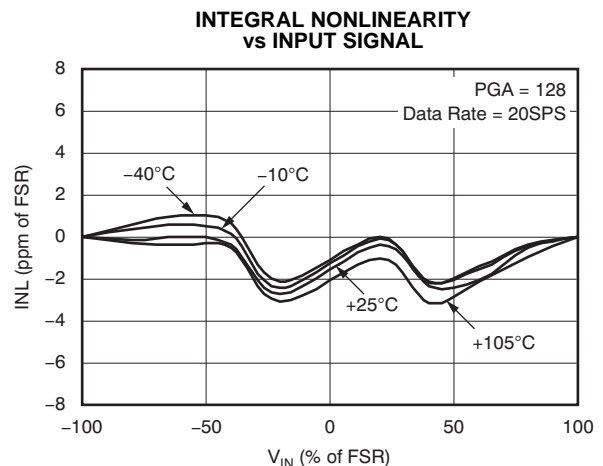

Figure 22.

TYPICAL CHARACTERISTICS (continued)

At $T_A = +25^\circ\text{C}$, $AVDD = DVDD = 5\text{V}$, $V_{REF} = 2.5\text{V}$, and $AVSS = DVSS = 0\text{V}$, unless otherwise noted.

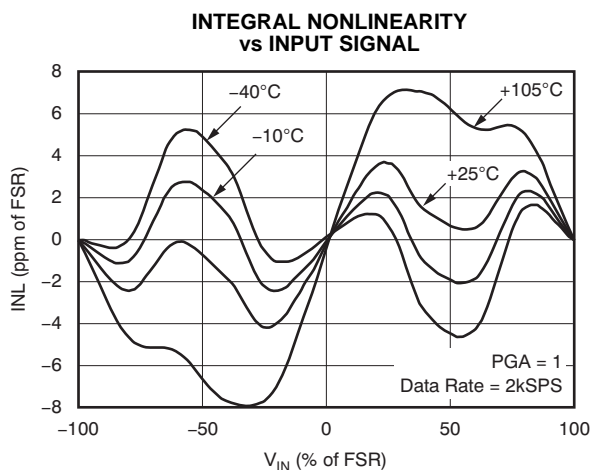

Figure 23.

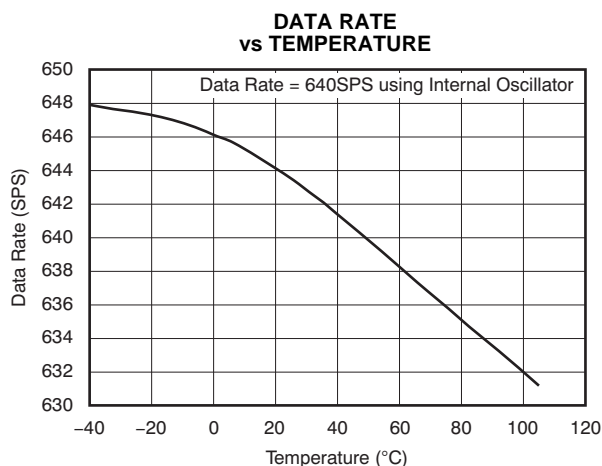

Figure 24.

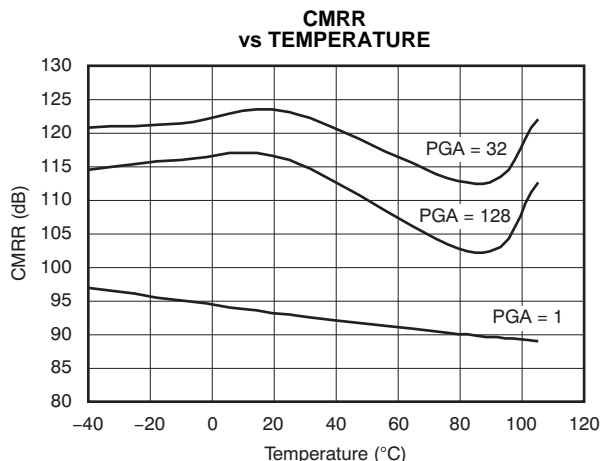

Figure 25.

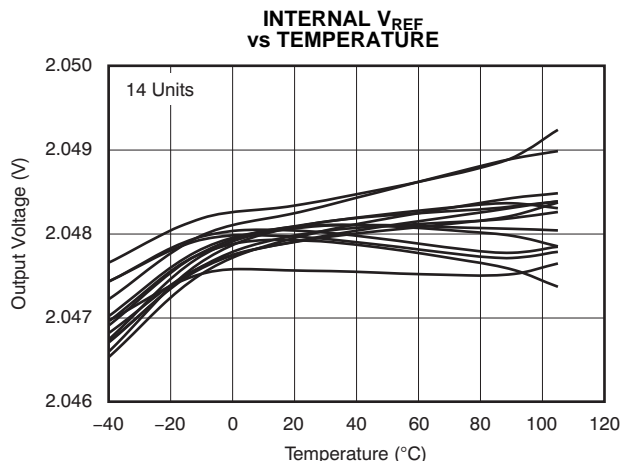

Figure 26.

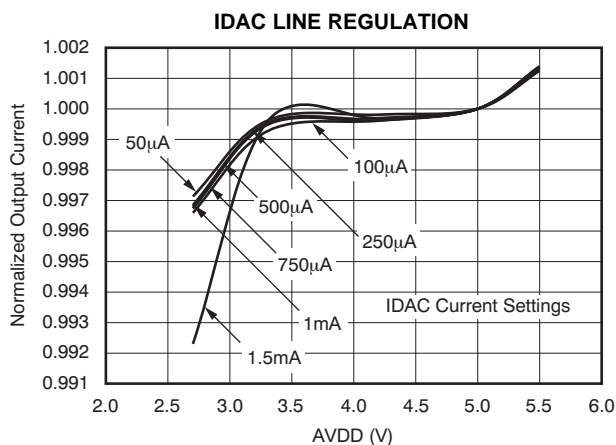

Figure 27.

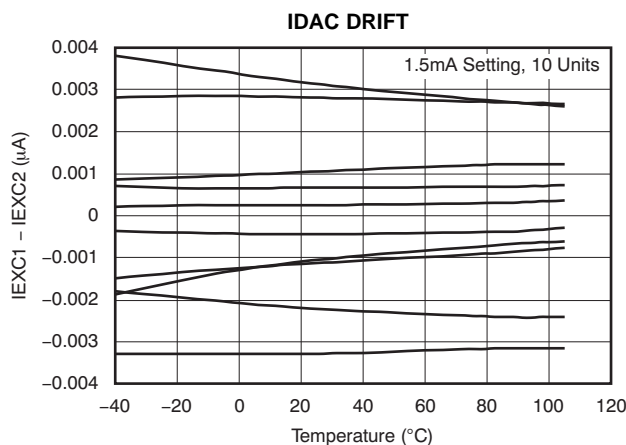

Figure 28.

GENERAL DESCRIPTION

OVERVIEW

The ADS1246/47/48 are highly integrated, low-noise, 24-bit, delta-sigma ADCs. They include a flexible input multiplexer, a low-noise, high input impedance PGA, a built-in very low drift voltage reference with 10mA output capability (ADS1247/48), an internal temperature sensor, and two highly-matched current sources. An SPI-compatible serial communication interface is also provided. A set of simple commands control the ADS1246/47/48 devices.

The ADS1246/47/48 provide two conversion modes: single-conversion and continuous-conversion. In single-conversion mode, the ADC converts the input signal once and the conversion result (data) is stored in the data register. The data can be read any time before the next conversion. Single-conversion mode can be started by applying a pulse to the START pin or by executing an SPI command. Upon completing the conversion, the device goes into sleep mode to minimize power consumption.

The ADS1246/47/48 also provide a system monitor function that monitors the external voltage references, analog power-supply voltage, digital power supply, and onboard temperature. The burnout current source can be used to detect sensor open-circuit conditions.

The ADS1246/47/48 simultaneously reject 50Hz and 60Hz interference with greater than 100dB rejection ratio for data rates up to 20SPS.

ADC INPUT AND MULTIPLEXER

The ADS1246/47/48 ADC measures the input signal through the onboard PGA. All analog inputs are connected to the internal AIN_P or AIN_N analog inputs through the analog multiplexer. A block diagram of the analog input multiplexer is shown in [Figure 29](#).

The input multiplexer connects to eight (ADS1248), four (ADS1247), or two (ADS1246) analog inputs that

can be configured as single-ended inputs, differential inputs, or in a combination of single-ended and differential inputs. The multiplexer also allows the on-chip excitation current and/or bias voltage to be selected to a specific channel.

Any analog input pin can be selected as the positive input or negative input through the MUX0 register. The ADS1246/47/48 have a true fully differential mode, meaning that the input signal range can be from –2.5V to +2.5V (when AVDD = 2.5V and AVSS = –2.5V).

Through the input multiplexer, the ambient temperature (internal temperature sensor), AVDD, DVDD, and external reference can all be selected for measurement. Refer to the [System Monitor](#) section for details.

On the ADS1247 and ADS1248, the analog inputs can also be configured as general-purpose inputs/outputs (GPIOs). See the [General-Purpose Digital I/O](#) section for more details.

ESD diodes protect the ADC inputs. To prevent these diodes from turning on, make sure the voltages on the input pins do not go below AVSS by more than 100mV, and do not exceed AVDD by more than 100mV, as shown in [Equation 1](#). Note that the same caution is true if the inputs are configured to be GPIOs.

$$AVSS - 100mV < (AINX) < AVDD + 100mV \quad (1)$$

Settling Time for Channel Multiplexing

The ADS1246/47/48 is a true single-cycle settling, delta-sigma converter. After the internal multiplexer switches, the very first data are valid.

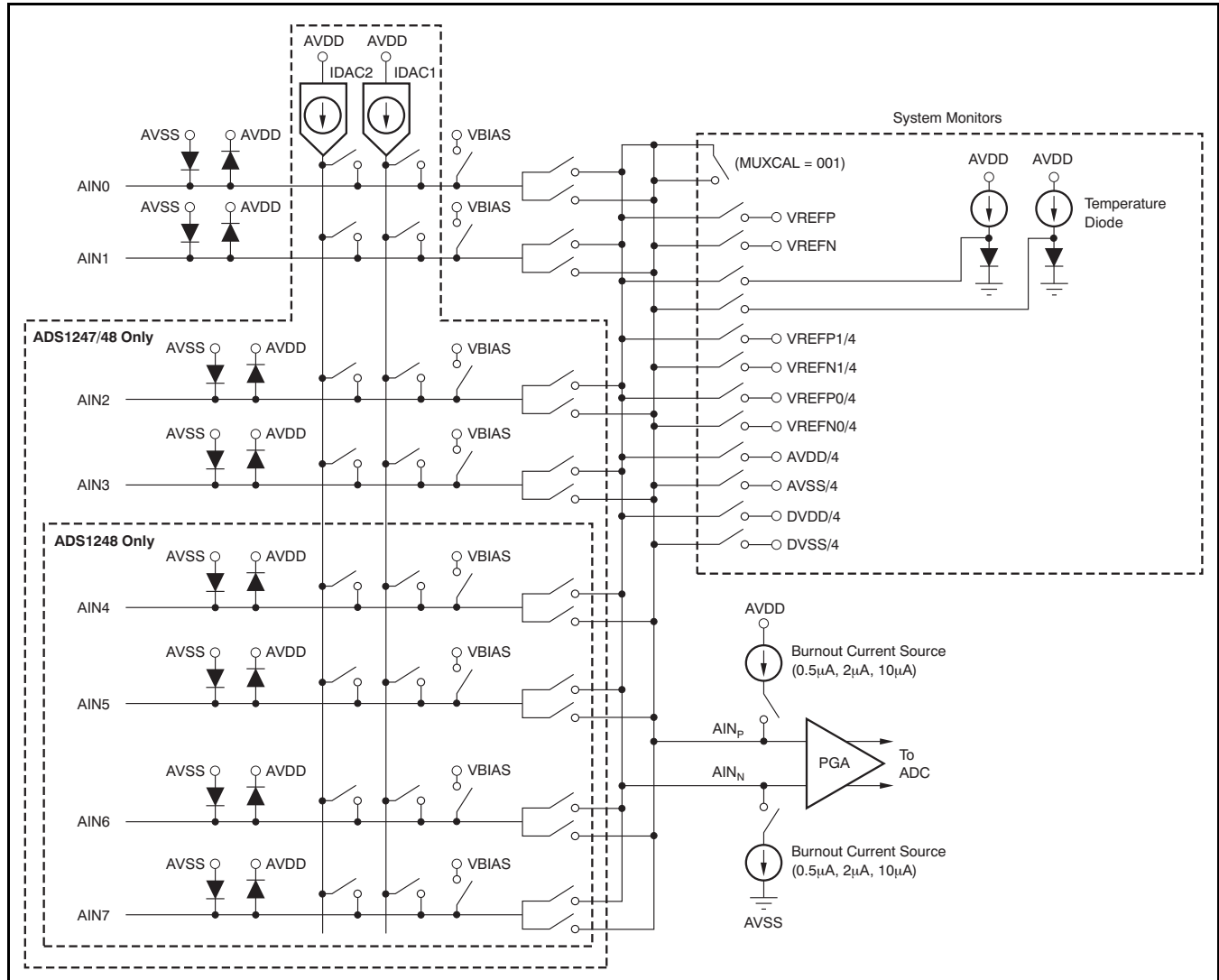

Figure 29. Analog Input Multiplexer Circuit

VOLTAGE REFERENCE INPUT

The voltage reference for the ADS1246/47/48 is the differential voltage between REFP and REFN:

$$V_{REF} = V_{REFP} - V_{REFN}$$

In the case of the ADS1246, these pins are dedicated inputs. For the ADS1247 and ADS1248, there is a multiplexer that selects the reference inputs, as shown in Figure 30. The reference input uses a buffer to increase the input impedance.

As with the analog inputs, REFP0 and REFN0 can be configured as digital I/Os on the ADS1247/48.

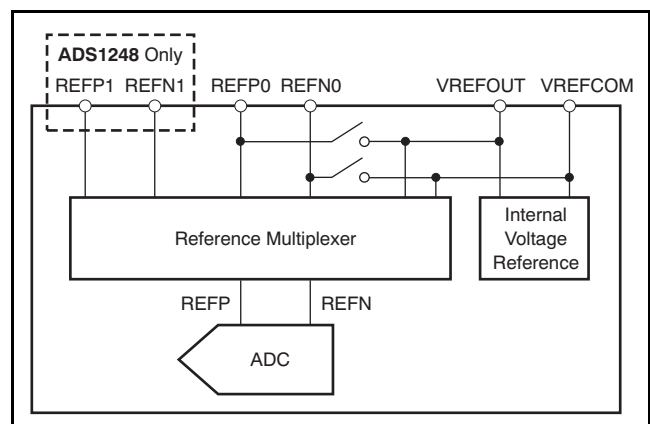

Figure 30. Reference Input Multiplexer

The reference input circuit has ESD diodes to protect the inputs. To prevent the diodes from turning on, make sure the voltage on the reference input pin is not less than $AVSS - 100\text{mV}$, and does not exceed $AVDD + 100\text{mV}$, as shown in Equation 2:

$$AVSS - 100\text{mV} < (V_{\text{REFP}} \text{ or } V_{\text{REFN}}) < AVDD + 100\text{mV} \quad (2)$$

LOW-NOISE PGA

The ADS1246/47/48 feature a low-drift, low-noise, high input impedance programmable gain amplifier (PGA). The PGA can be set to gain of 1, 2, 4, 8, 16, 32, 64, or 128 by register SYS0. A simplified diagram of the PGA is shown in Figure 31.

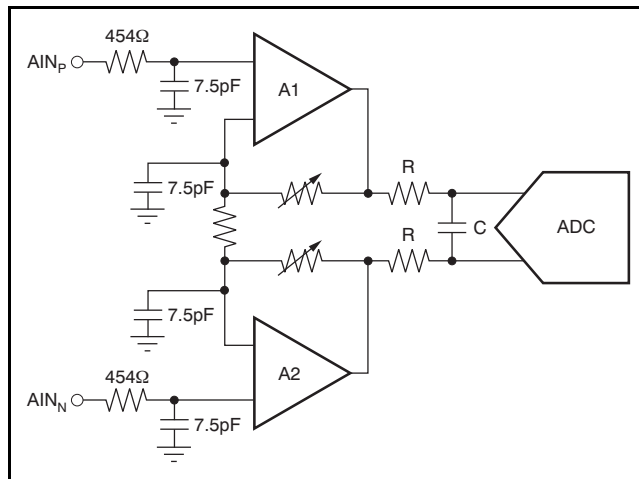

Figure 31. Simplified Diagram of the PGA

The PGA consists of two chopper-stabilized amplifiers (A1 and A2) and a resistor feedback network that sets the gain of the PGA. The PGA input is equipped with an electromagnetic interference (EMI) filter, as shown in Figure 31. Note that as with any PGA, it is necessary to ensure that the input voltage stays within the specified common-mode input range specified in the Electrical Characteristics. The common-mode input (V_{CMI}) must be within the range shown in Equation 3:

$$\left(AVSS + 0.1\text{V} + \frac{(V_{\text{IN}})(\text{Gain})}{2} \right) \leq V_{\text{CMI}} \leq \left(AVDD - 0.1\text{V} - \frac{(V_{\text{IN}})(\text{Gain})}{2} \right) \quad (3)$$

MODULATOR

A third-order modulator is used in the ADS1246/47/48. The modulator converts the analog input voltage into a pulse code modulated (PCM) data stream. To save power, the modulator clock runs from 32kHz up to 512kHz for different data rates, as shown in Table 9.

Table 9. Modulator Clock Frequency for Different Data Rates

| DATA RATE (SPS) | f_{MOD} (kHz) |
|-----------------|------------------------|
| 5, 10, 20 | 32 |
| 40, 80, 160 | 128 |
| 320, 640, 1000 | 256 |
| 2000 | 512 |

DIGITAL FILTER FREQUENCY RESPONSE

The ADS1246/47/48 use linear-phase finite impulse response (FIR) digital filters that can be programmed for different output data rates. The digital filters always settle in a single cycle; therefore, the settling time is the inverse of the data rate.

The ADS1246/47/48 provide simultaneous 50Hz and 60Hz rejection for data rates less than or equal to 20SPS. Table 10 shows the signal -3dB bandwidth for a specific data rate and the attenuation around both 50Hz and 60Hz for 20SPS or less. The frequency responses of the digital filter are shown in Figure 32 to Figure 42. Figure 35 shows a detailed view of the filter frequency response from 48Hz to 62Hz for a 20SPS data rate. All filter plots are generated with 4.096MHz external clock.

Table 10. Digital Filter Performance with Different Data Rates

| DATA RATE (SPS) | -3dB BANDWIDTH (Hz) | ATTENUATION | | | |
|-----------------|---------------------|---|---|---|---|
| | | $f_{\text{IN}} = 50\text{Hz} \pm 0.3\text{Hz}$ (dB) | $f_{\text{IN}} = 60\text{Hz} \pm 0.3\text{Hz}$ (dB) | $f_{\text{IN}} = 50\text{Hz} \pm 1\text{Hz}$ (dB) | $f_{\text{IN}} = 60\text{Hz} \pm 1\text{Hz}$ (dB) |
| 5 | 2.26 | -106 | -74 | -81 | -69 |
| 10 | 4.76 | -106 | -74 | -80 | -69 |
| 20 | 14.8 | -71 | -74 | -66 | -68 |
| 40 | 9.03 | | | | |
| 80 | 19.8 | | | | |
| 160 | 118 | | | | |
| 320 | 154 | | | | |
| 640 | 495 | | | | |
| 1000 | 732 | | | | |
| 2000 | 1465 | | | | |

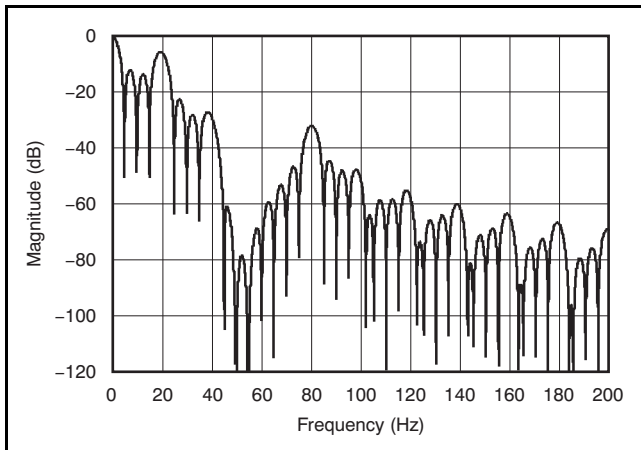

Figure 32. Filter Profile with Data Rate = 5SPS

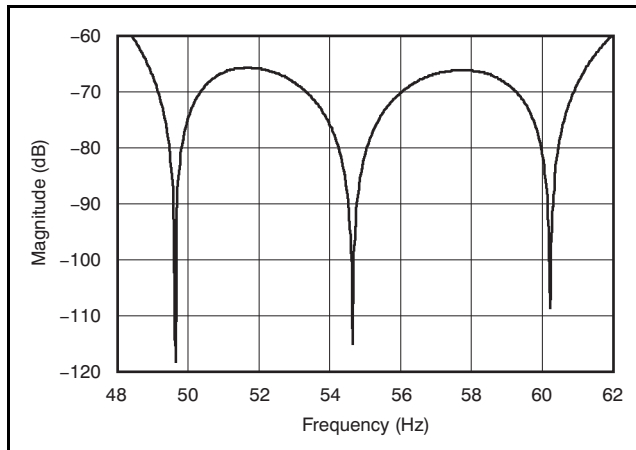

Figure 35. Detailed View of Filter Profile with Data Rate = 20SPS between 48Hz and 62Hz

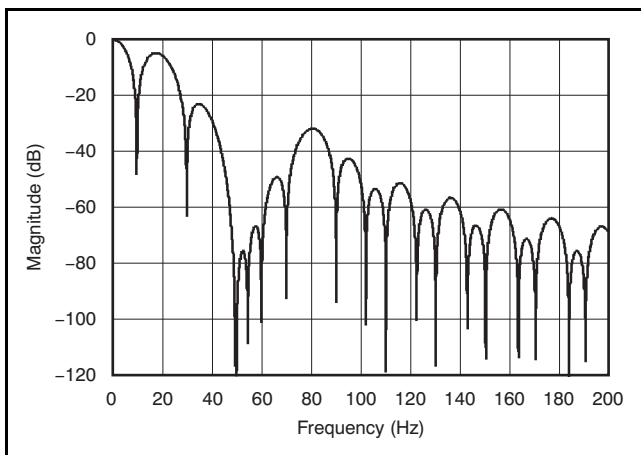

Figure 33. Filter Profile with Data Rate = 10SPS

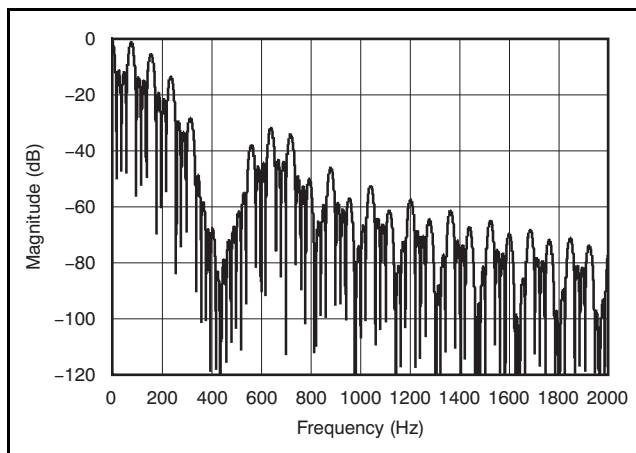

Figure 36. Filter Profile with Data Rate = 40SPS

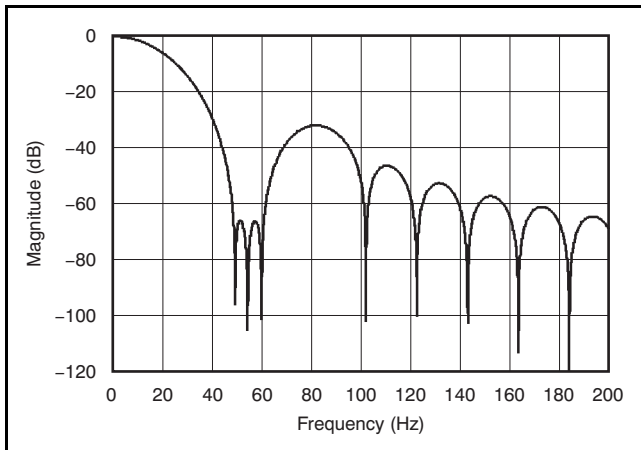

Figure 34. Filter Profile with Data Rate = 20SPS

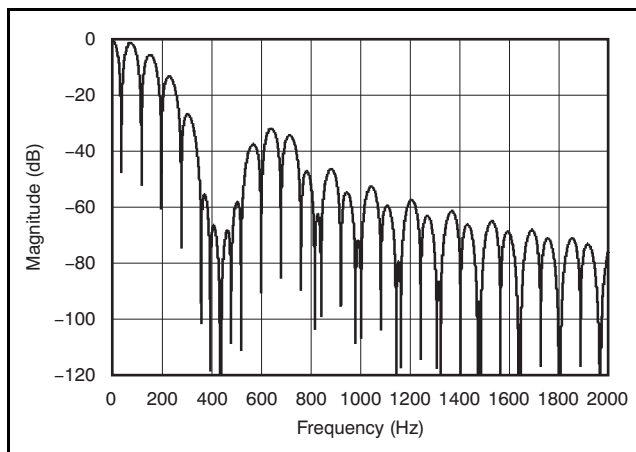

Figure 37. Filter Profile with Data Rate = 80SPS

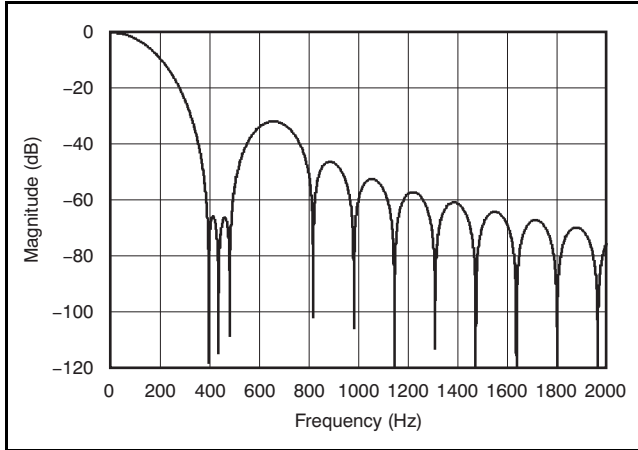

Figure 38. Filter Profile with Data Rate = 160SPS

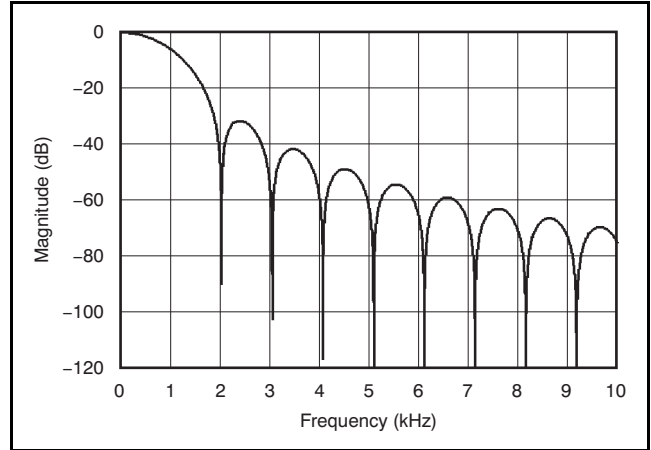

Figure 41. Filter Profile with Data Rate = 1kSPS

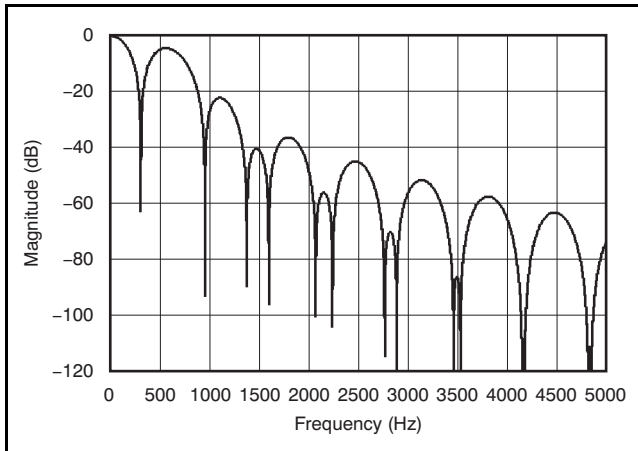

Figure 39. Filter Profile with Data Rate = 320SPS

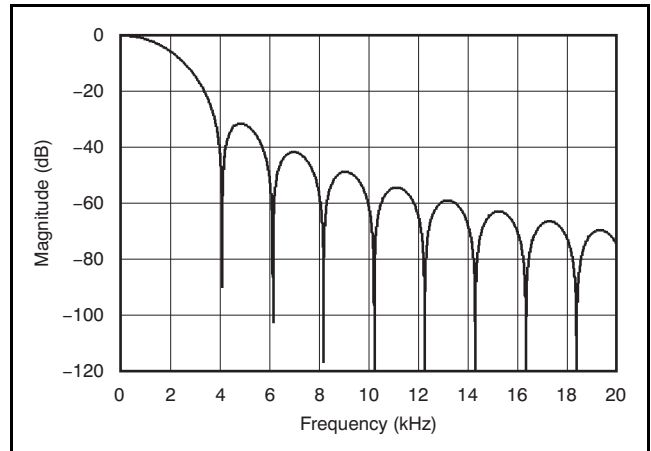

Figure 42. Filter Profile with Data Rate = 2kSPS

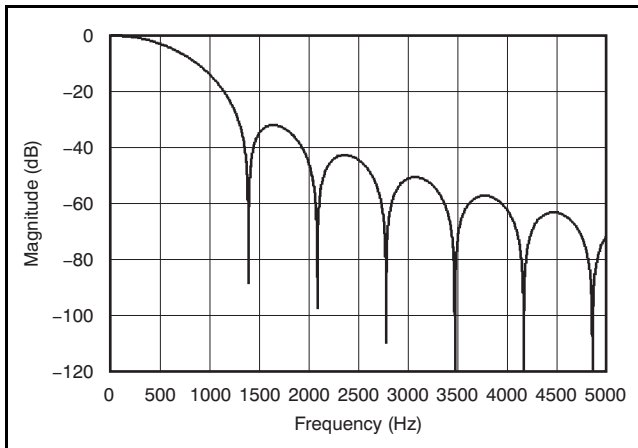

Figure 40. Filter Profile with Data Rate = 640SPS

CLOCK SOURCE

The ADS1246/47/48 can use either the internal oscillator or an external clock. Connect the CLK pin to DGND before power-on or reset to activate the internal oscillator. Connecting an external clock to the CLK pin at any time deactivates the internal oscillator, with the device then operating on the external clock. After the device switches to the external clock, it cannot be switched back to the internal oscillator without performing a power-on sequence or resetting the device.

INTERNAL VOLTAGE REFERENCE

The ADS1247/48 includes an onboard voltage reference with a low temperature coefficient. The output of the voltage reference is 2.048V with the capability of both sourcing and sinking up to 10mA of current.

The voltage reference must have a capacitor connected between VREFOUT and VREFCOM. The value of the capacitance should be in the range of 1 μ F to 47 μ F. Large values provide more filtering of the reference; however, the turn-on time increases with capacitance, as shown in [Table 11](#). For stability reasons, VREFCOM must have a path with an impedance less than 10 Ω to ac ground nodes, such as AVSS (for a 0V to 5V analog power supply), or GND (for a \pm 2.5V analog power supply). In case this impedance is higher than 10 Ω , a capacitor of at least 0.1 μ F should be connected between VREFCOM and an ac ground node (for example, GND). Note that because it takes time for the voltage reference to settle to the final voltage, care must be taken when the device is turned off between conversions. Allow adequate time for the internal reference to fully settle.

Table 11. Internal Reference Settling Time

| VREFOUT CAPACITOR | SETTLING ERROR | TIME TO REACH THE SETTLING ERROR |
|-------------------|----------------|----------------------------------|
| 1 μ F | \pm 0.5% | 70 μ s |
| | \pm 0.1% | 110 μ s |
| 4.7 μ F | \pm 0.5% | 290 μ s |
| | \pm 0.1% | 375 μ s |
| 47 μ F | \pm 0.5% | 2.2ms |
| | \pm 0.1% | 2.4ms |

The onboard reference is controlled by the registers; by default, it is off after startup (see the [ADS1247/48 Detailed Register Definitions](#) section for more details). Therefore, the internal reference must first be turned on and then connected via the internal reference multiplexer. Because the onboard reference is used to generate the current reference for the excitation current sources, it must be turned on before the excitation currents become available.

EXCITATION CURRENT SOURCE DACS

The ADS1247/48 provide two matched excitation current sources for RTD applications. For three- or four-wire RTD applications, the matched current sources can be used to cancel the errors caused by sensor lead resistance. The output current of the current source DACs can be programmed to 50 μ A, 100 μ A, 250 μ A, 500 μ A, 750 μ A, 1000 μ A, or 1500 μ A.

The two matched current sources can be connected to dedicated current output pins IOUT1 and IOUT2 (ADS1248 only), or to any AIN pin (ADS1247/48); refer to the [ADS1247/48 Detailed Register Definitions](#) section for more information. It is possible to connect both current sources to the same pin. Note that the internal reference must be turned on and properly compensated when using the excitation current source DACs.

SENSOR DETECTION

The ADS1246/47/48 provide a selectable current (0.5 μ A, 2 μ A, or 10 μ A) to help detect a possible sensor malfunction.

When enabled, two burnout current sources flow through the selected pair of analog inputs to the sensor. One sources the current to the positive input channel, and the other sinks the same current from the negative input channel.

When the burnout current sources are enabled, a full-scale reading may indicate an open circuit in the front-end sensor, or that the sensor is overloaded. It may also indicate that the reference voltage is absent. A near zero reading may indicate a short-circuit in the sensor.

BIAS VOLTAGE GENERATION

A selectable bias voltage is provided for use with ungrounded thermocouples. The bias voltage is (AVDD + AVSS)/2 and can be applied to any analog input channel through internal input multiplexer. The bias voltage turn-on times for different sensor capacitances are listed in [Table 12](#).

Table 12. Bias Voltage Settling Time

| SENSOR CAPACITANCE | SETTLING TIME |
|--------------------|---------------|
| 0.1 μ F | 220 μ s |
| 1 μ F | 2.2ms |
| 10 μ F | 22ms |
| 200 μ F | 450ms |

GENERAL-PURPOSE DIGITAL I/O

The ADS1248 has eight pins and the ADS1247 has four pins that serve a dual purpose as either analog inputs or general-purpose digital inputs/outputs (GPIOs).

Figure 43 shows a diagram of how these functions are combined onto a single pin. Note that when the pin is configured as a GPIO, the corresponding logic is powered from AVDD and AVSS. When the ADS1247/48 are operated with bipolar analog supplies, the GPIO outputs bipolar voltages. Care must be taken loading the GPIO pins when used as outputs because large currents can cause droop or noise on the analog supplies.

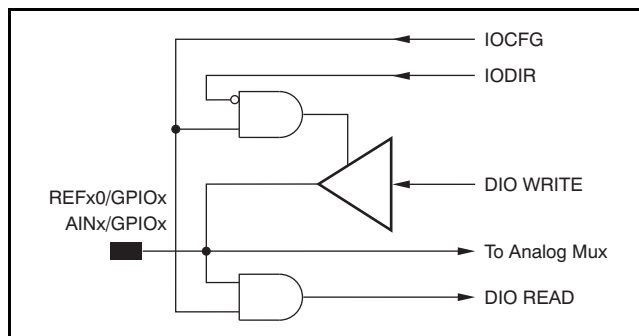

Figure 43. Analog/Data Interface Pin

SYSTEM MONITOR

The ADS1246/47/48 provide a system monitor function. This function can measure the analog power supply, digital power supply, external voltage reference, or ambient temperature. Note that the system monitor function provides a coarse result. When the system monitor is enabled, the analog inputs are disconnected.

Power-Supply Monitor

The system monitor can measure the analog or digital power supply. When measuring the power supply, the resulting conversion is approximately 1/4 of the actual power supply voltage.

$$\text{Conversion result} = (V_{SP}/4)/V_{REF} \quad (4)$$

Where V_{SP} is the selected supply to be measured.

External Voltage Reference Monitor

The ADS1246/47/48 can be selected to measure the external voltage reference. In this configuration, the monitored external voltage reference is connected to the analog input. The result (conversion code) is approximately 1/4 of the actual reference voltage.

$$\text{Conversion result} = (V_{REX}/4)/V_{REF} \quad (5)$$

Where V_{REX} is the external reference to be monitored.

NOTE: The internal reference voltage must be enabled when measuring an external voltage reference using the system monitor.

Ambient Temperature Monitor

On-chip diodes provide temperature-sensing capability. When selecting the temperature monitor function, the anodes of two diodes are connected to the ADC. Typically, the difference in diode voltage is 111.7mV at +25°C with a temperature coefficient of 379 μ V/°C.

Note that when the onboard temperature monitor is selected, the PGA is automatically set to '1'. However, the PGA register bits in are not affected and the PGA returns to its set value when the temperature monitor is turned off.

POWER-UP SEQUENCE

When DVDD is pulled up, a $\overline{\text{RESET}}$ pulse must be issued as shown in Figure 44. Alternately, the sequence shown in Figure 45 may be used if the $\overline{\text{RESET}}$ pin is tied high in the application. This sequence is required in order to initialize the device to the correct state after power-up or supply brownout (when the supply drops below 1.8V). Note that if it is required to subsequently reset the chip, the RESET command or the RESET pin must be used.

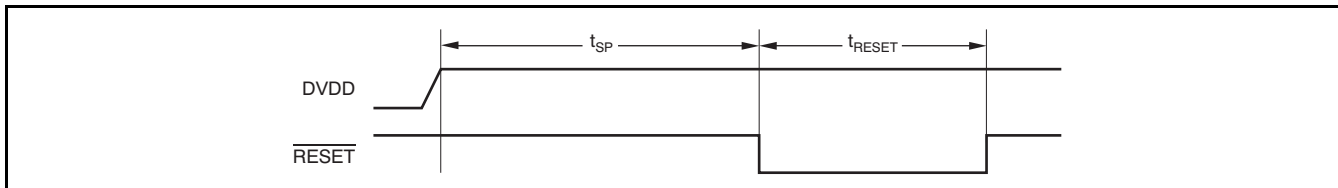

Figure 44. Power-up Sequence Timing using Hardware Reset

Table 13. Timing Characteristics for Figure 44

| SYMBOL | DESCRIPTION | MIN | MAX | UNIT |
|-------------|--|-----|-----|------|
| t_{SP} | DVDD settled to \overline{RESET} pulse | 100 | | ms |
| t_{RESET} | \overline{RESET} pulse width | 1 | | ms |

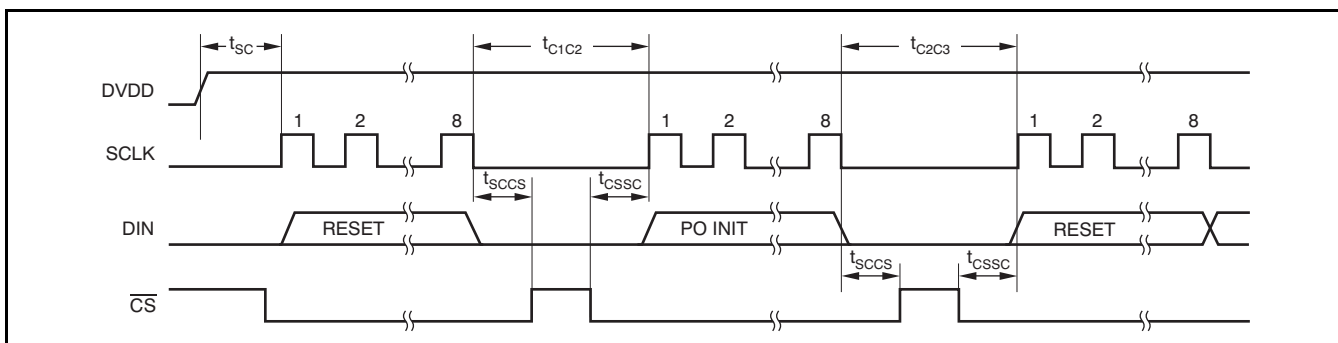

Figure 45. Power-up Sequence Timing using Software Reset

Table 14. Timing Characteristics for Figure 45⁽¹⁾

| SYMBOL | DESCRIPTION | MIN | MAX | UNIT |
|------------|---|-----|-----|------|
| t_{sc} | DVDD settled to RESET command | 100 | | ms |
| t_{C1C2} | Time between first RESET command and STARTUP command | 10 | | ms |
| t_{C2C3} | Time between first STARTUP command and second RESET command | 10 | | ms |

(1) Values for t_{sccs} and t_{cssc} can be found in Table 1.

CALIBRATION

Calibration can effectively reduce gain error and offset error. The ADS1246/47/48 provide three types of calibration: system gain calibration, system offset calibration, and self offset calibration. If absolute accuracy is required, calibration must be performed after power on, a change in temperature, a change of channel, or a change of PGA. At the completion of calibration, the $\overline{\text{DRDY}}$ signal goes low, indicating the calibration is finished. The first data after calibration are always valid. If the START pin is taken low or a SLEEP command is issued after any calibration command, the device goes to sleep after completing the calibration.

System Gain Calibration

System gain calibration reduces the gain error caused by the device and the signal path. The system gain calibration can be initialized at anytime by sending the system gain calibration command (SYSGCAL) while applying a full-scale input on the selected analog inputs. The calibrated value is stored in the 24-bit, full-scale calibration register (FSC). Issuing a gain calibration command is recommended after changing the channel to ensure the most accurate result.

When a system gain calibration command is issued, the ADS1246/47/48 stop the current conversion and start the calibration procedure immediately.

System Offset Calibration and Self Offset Calibration

The ADS1246/47/48 also provide system offset calibration and self offset calibration. System offset calibration corrects both internal and external offset errors. The system offset calibration command (SYSOCAL) requires that a zero input differential signal be applied to the selected analog inputs; it then computes the offset that nullifies the offset in the system.

In the self offset calibration, a self offset calibration command (SELFOCAL) is issued, and the device internally shorts the inputs and performs the calibration. The calibration result is stored in the offset calibration register (OFC).

ADC SLEEP MODE

Power consumption can be dramatically reduced by placing the ADS1246/47/48 into sleep mode. There are two ways to put the device into sleep mode: the sleep command (SLEEP) and through the START pin.

During sleep mode, the internal reference status depends on the setting of the VREFCON bits in the MUX1 register; see the [Register Descriptions](#) section for details.

ADC OPERATION CONTROL

ADC Control Signals

The ADS1246/47/48 provide a set of control pins to allow full control of the data conversion process.

START

The START pin provides easy and precise control of conversions. Pulse the START pin high to begin a conversion, as shown in [Figure 46](#) and [Table 15](#). The conversion completion is indicated by the $\text{DOUT}/\overline{\text{DRDY}}$ pin going low. When the conversion completes, the ADS1246/47/48 automatically shuts down to save power. During shutdown, the conversion result can be retrieved; however, START must be taken high before communicating with the configuration registers. The device stays shut down until the START pin is once again taken high to begin a new conversion. When the START pin is taken back high again, the decimation filter is held in a reset state for 32 modulator clock cycles internally to allow the analog circuits to settle.

The ADS1246/47/48 can be configured to convert continuously by holding the START pin high, as shown in [Figure 47](#). With the START pin held high, the ADC converts the selected input channels continuously. This configuration continues until the START pin is taken low.

The START pin can also be used to perform the synchronized measurement for the multi-channel applications by pulsing the START pin.

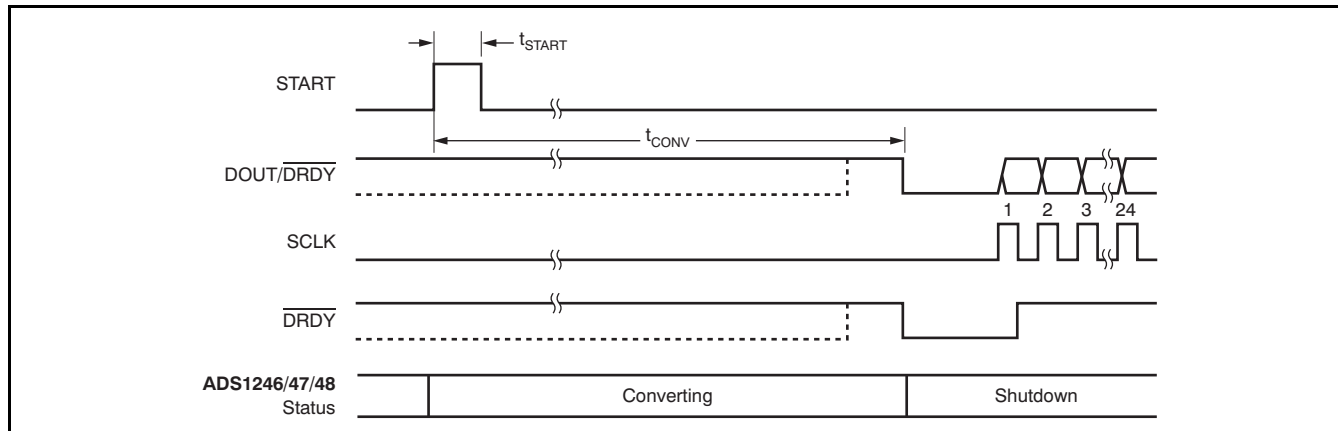
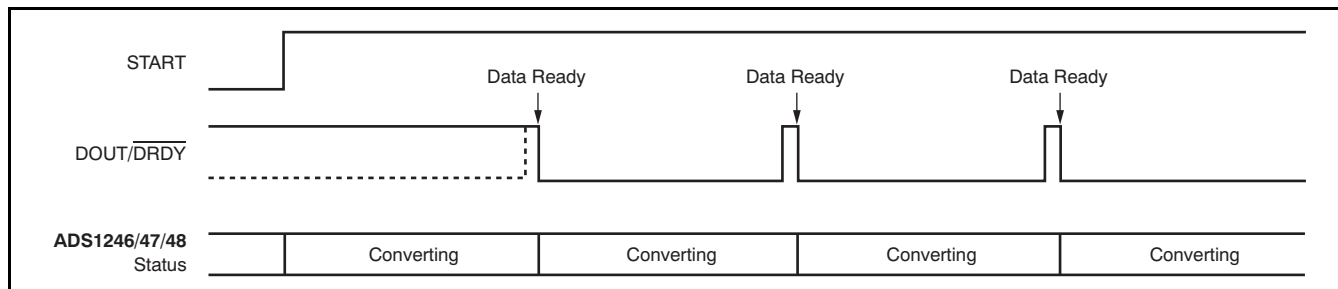

Figure 46. Timing for Single Conversion Using START Pin

Table 15. START Pin Conversion Times for Figure 46

| SYMBOL | DESCRIPTION | DATA RATE (SPS) | VALUE | UNIT |
|------------|--|-----------------|---------|------|
| t_{CONV} | Time from START pulse to \overline{DRDY} and DOUT/ \overline{DRDY} going low | 5 | 200.295 | ms |
| | | 10 | 100.644 | ms |
| | | 20 | 50.825 | ms |
| | | 40 | 25.169 | ms |
| | | 80 | 12.716 | ms |
| | | 160 | 6.489 | ms |
| | | 320 | 3.247 | ms |
| | | 640 | 1.692 | ms |
| | | 1000 | 1.138 | ms |
| | | 2000 | 0.575 | ms |



NOTE: SCLK held low in this example.

Figure 47. Timing for Conversion with START Pin High

RESET

When the $\overline{\text{RESET}}$ pin goes low, the device is immediately reset. All the registers are restored to default values. The device stays in reset mode as long as the $\overline{\text{RESET}}$ pin stays low. When it goes high, the ADC comes out of reset mode and is able to convert data. After the $\overline{\text{RESET}}$ pin goes high, and when the system clock frequency is 4.096MHz, the digital filter and the registers are held in a reset state for 0.6ms when $f_{\text{OSC}} = 4.096\text{MHz}$. Therefore, valid SPI communication can only be resumed 0.6ms after the $\overline{\text{RESET}}$ pin goes high, as shown in [Figure 4](#). When the $\overline{\text{RESET}}$ pin goes low, the clock selection is reset to the internal oscillator.

Digital Filter Reset Operation

Apart from the RESET command and the $\overline{\text{RESET}}$ pin, the digital filter is reset automatically when either a write operation to the MUX0, VBIAS, MUX1, or SYS0 registers is performed, or when a SYNC command is issued. The time that the filter is held in reset varies according to the operation.

The filter is reset two system clocks after the last bit of the SYNC command is sent. The reset pulse created internally lasts for two multiplier clock cycles. If any write operation takes place in the MUX0 register, the filter is reset regardless of whether the value changed or not. Internally, the filter pulse lasts for two system clock periods. If any write activity takes place in the VBIAS, MUX1, or SYS0 registers, the filter is reset as well, regardless of whether the value changed or not. The reset pulse lasts for 32 modulator clocks after the write operation. If there are multiple write operations, the resulting reset pulse may be viewed as the ANDed result of the different active low pulses created individually by each action.

SPI Control Signals

The ADS1246/47/48 provide a standard SPI serial communication interface plus a data ready signal (DRDY). Communication is full-duplex with the exception of a few limitations in regards to the RREG command and the RDATA command. These limitations are explained in detail in the [SPI Commands](#) section of this data sheet. For the basic serial interface timing characteristics, see [Figure 1](#) and [Figure 2](#) of this datasheet.

\overline{CS}

The chip select pin (active low). The \overline{CS} pin activates SPI communication. \overline{CS} must be low before data transactions and must stay low for the entire SPI communication period. When \overline{CS} is high, the DOUT/DRDY pin enters a high-impedance state. Therefore, reading and writing to the serial interface are ignored and the serial interface is reset. \overline{DRDY} pin operation is independent of \overline{CS} .

Taking \overline{CS} high deactivates only the SPI communication with the device. Data conversion continues and the \overline{DRDY} signal can be monitored to check if a new conversion result is ready. A master device monitoring the \overline{DRDY} signal can select the appropriate slave device by pulling the \overline{CS} pin low.

SCLK

The serial clock signal. SCLK provides the clock for serial communication. It is a Schmitt-trigger input, but it is highly recommended that SCLK be kept as clean as possible to prevent glitches from inadvertently shifting the data. Data are shifted into DIN on the falling edge of SCLK and shifted out of DOUT on the rising edge of SCLK.

DIN

The data input pin. DIN is used along with SCLK to send data to the device. Data on DIN are shifted into the device on the falling edge of SCLK.

The communication of this device is full-duplex in nature. The device monitors commands shifted in even when data are being shifted out. Data that are present in the output shift register are shifted out when sending in a command. Therefore, it is important to make sure that whatever is being sent on the DIN pin is valid when shifting out data. When no command is to be sent to the device when reading out data, the NOP command should be sent on DIN.

\overline{DRDY}

The data ready pin. The \overline{DRDY} pin goes low to indicate a new conversion is complete, and the conversion result is stored in the conversion result buffer. The SPI clock must be low in a short time frame around the \overline{DRDY} low transition (see [Figure 2](#)) so that the conversion result is loaded into both the

result buffer and the output shift register. Therefore, no commands should be issued during this time frame if the conversion result is to be read out later. This constraint applies only when \overline{CS} is asserted. When \overline{CS} is not asserted, SPI communication with other devices on the SPI bus does not affect loading of the conversion result. After the \overline{DRDY} pin goes low, it is forced high on the first falling edge of SCLK (so that the \overline{DRDY} pin can be polled for '0' instead of waiting for a falling edge). If the \overline{DRDY} pin is not taken high after it falls low, a short high pulse is created on it to indicate the next data are ready.

DOUT/ \overline{DRDY}

This pin has two modes: data out (DOUT) only, or data out (DOUT) combined with data ready (\overline{DRDY}). The DRDY MODE bit determines the function of this pin. In either mode, the DOUT/ \overline{DRDY} pin goes to a high-impedance state when \overline{CS} is taken high.

When the DRDY MODE bit is set to '0', this pin functions as DOUT only. Data are clocked out at rising edge of SCLK, MSB first (see [Figure 48](#)).

When the DRDY MODE bit is set to '1', this pin functions as both DOUT and \overline{DRDY} . Data are shifted out from this pin, MSB first, at the rising edge of SCLK. This combined pin allows for the same control but with fewer pins.

When the DRDY MODE bit is enabled and a new conversion is complete, DOUT/ \overline{DRDY} goes low if it is high. If it is already low, then DOUT/ \overline{DRDY} goes high and then goes low (see [Figure 49](#)). Similar to the \overline{DRDY} pin, a falling edge on the DOUT/ \overline{DRDY} pin signals that a new conversion result is ready. After DOUT/ \overline{DRDY} goes low, the data can be clocked out by providing 24 SCLKs. In order to force DOUT/ \overline{DRDY} high (so that DOUT/ \overline{DRDY} can be polled for a '0' instead of waiting for a falling edge), a no operation command (NOP) or any other command that does not load the data output register can be sent after reading out the data. Because SCLKs can only be sent in multiples of eight, a NOP can be sent to force DOUT/ \overline{DRDY} high if no other command is pending. The DOUT/ \overline{DRDY} pin goes high after the first rising edge of SCLK after reading the conversion result completely (see [Figure 50](#)). The same condition also applies after an RREG command. After all the register bits have been read out, the rising edge of SCLK forces DOUT/ \overline{DRDY} high. [Figure 51](#) illustrates an example where sending four NOP commands after an RREG command forces the DOUT/ \overline{DRDY} pin high.

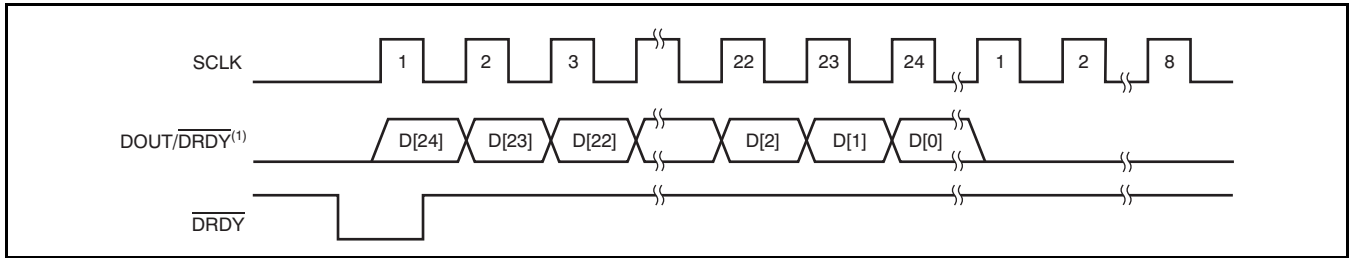

(1) \overline{CS} tied low.

Figure 48. Data Retrieval with the DRDY MODE Bit = 0 (disabled)

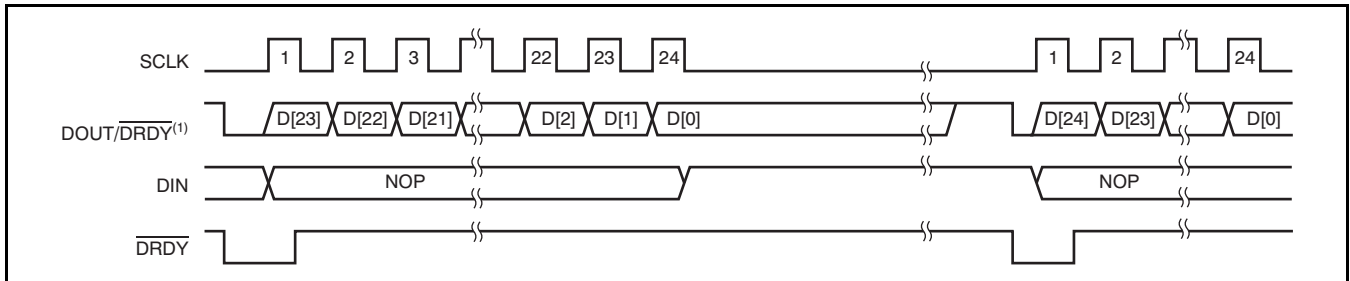

(1) \overline{CS} tied low.

Figure 49. Data Retrieval with the DRDY MODE Bit = 1 (enabled)

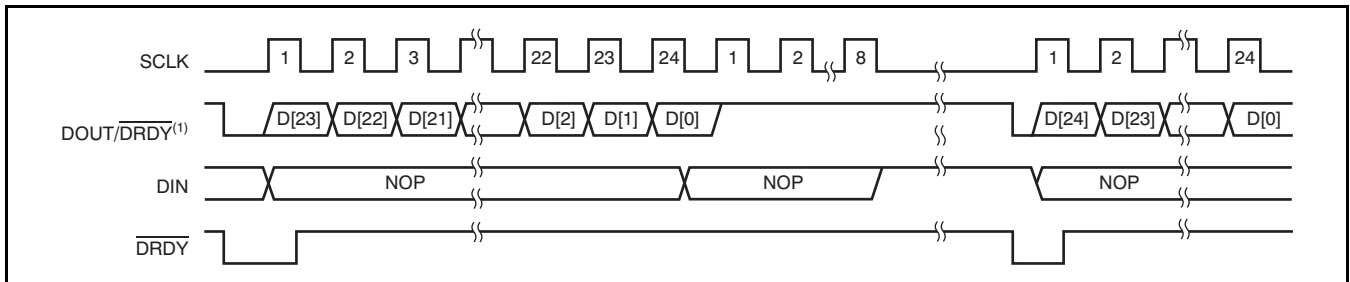

(1) DRDY MODE bit enabled, \overline{CS} tied low.

Figure 50. DOUT/DRDY Forced High After Retrieving the Conversion Result

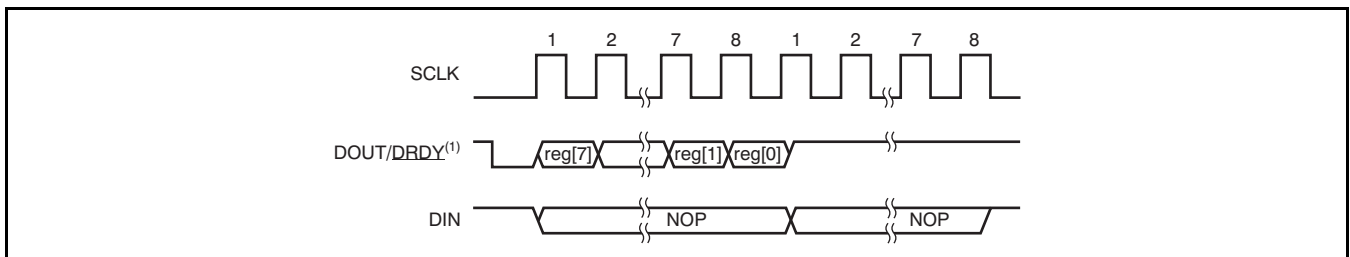

(1) DRDY MODE bit enabled, \overline{CS} tied low.

Figure 51. DOUT/DRDY Forced High After Reading Register Data

The DRDY MODE bit modifies only the DOUT/ $\overline{\text{DRDY}}$ pin functionality. The $\overline{\text{DRDY}}$ pin functionality remains unaffected.

SPI Reset

SPI communication can be reset in several ways. In order to reset the SPI interface (without resetting the registers or the digital filter), the $\overline{\text{CS}}$ pin can be pulled high. Taking the $\overline{\text{RESET}}$ pin low causes the SPI interface to be reset along with all the other digital functions. In this case, the registers and the conversion are reset.

SPI Communication During Sleep Mode

When the START pin is low or the device is in sleep mode, only the RDATA, RDATA_C, S_{DATA}_C, WAKEUP, and NOP commands can be issued. The RDATA command can be used to repeatedly read the last conversion result during sleep mode. Other commands do not function because the internal clock is shut down to save power during sleep mode.

DATA FORMAT

The ADS1246/47/48 output 24 bits of data in binary twos complement format. The least significant bit (LSB) has a weight of $(V_{\text{REF}}/\text{PGA})/(2^{23} - 1)$. The positive full-scale input produces an output code of 7FFFFFFh and the negative full-scale input produces an output code of 800000h. The output clips at these codes for signals exceeding full-scale. [Table 16](#) summarizes the ideal output codes for different input signals.

Table 16. Ideal Output Code vs Input Signal

| INPUT SIGNAL, V_{IN} ($\text{AIN}_P - \text{AIN}_N$) | IDEAL OUTPUT CODE ⁽¹⁾ |
|--|----------------------------------|
| $\geq +V_{\text{REF}}/\text{PGA}$ | 7FFFFFFh |
| $(+V_{\text{REF}}/\text{PGA})/(2^{23} - 1)$ | 000001h |
| 0 | 000000h |
| $(-V_{\text{REF}}/\text{PGA})/(2^{23} - 1)$ | FFFFFFh |
| $\leq -(V_{\text{REF}}/\text{PGA}) \times (2^{23}/2^{23} - 1)$ | 800000h |

(1) Excludes effects of noise, linearity, offset, and gain errors.

REGISTER DESCRIPTIONS

ADS1246 REGISTER MAP

Table 17. ADS1246 Register Map

| ADDRESS | REGISTER | BIT 7 | BIT 6 | BIT 5 | BIT 4 | BIT 3 | BIT 2 | BIT 1 | BIT 0 |
|---------|----------|---------|-------|-------|-------|-----------|---------|---------|---------|
| 00h | BCS | BCS1 | BCS0 | 0 | 0 | 0 | 0 | 0 | 1 |
| 01h | VBIAS | 0 | 0 | 0 | 0 | 0 | 0 | VBIAS1 | VBIAS0 |
| 02h | MUX1 | CLKSTAT | 0 | 0 | 0 | 0 | MUXCAL2 | MUXCAL1 | MUXCAL0 |
| 03h | SYS0 | 0 | PGA2 | PGA1 | PGA0 | DR3 | DR2 | DR1 | DR0 |
| 04h | OFC0 | OFC7 | OFC6 | OFC5 | OFC4 | OFC3 | OFC2 | OFC1 | OFC0 |
| 05h | OFC1 | OFC15 | OFC14 | OFC13 | OFC12 | OFC11 | OFC10 | OFC9 | OFC8 |
| 06h | OFC2 | OFC23 | OFC22 | OFC21 | OFC20 | OFC19 | OFC18 | OFC17 | OFC16 |
| 07h | FSC0 | FSC7 | FSC6 | FSC5 | FSC4 | FSC3 | FSC2 | FSC1 | FSC0 |
| 08h | FSC1 | FSC15 | FSC14 | FSC13 | FSC12 | FSC11 | FSC10 | FSC9 | FSC8 |
| 09h | FSC2 | FSC23 | FSC22 | FSC21 | FSC20 | FSC19 | FSC18 | FSC17 | FSC16 |
| 0Ah | ID | ID3 | ID2 | ID1 | ID0 | DRDY MODE | 0 | 0 | 0 |

ADS1246 DETAILED REGISTER DEFINITIONS

BCS—Burnout Current Source Register. These bits control the settling of the sensor burnout detect current source.

| BCS - ADDRESS 00h | | | | | | | RESET VALUE = 01h | | |
|-------------------|-------|-------|-------|-------|-------|-------|-------------------|--|--|
| BIT 7 | BIT 6 | BIT 5 | BIT 4 | BIT 3 | BIT 2 | BIT 1 | BIT 0 | | |
| BCS1 | BCS0 | 0 | 0 | 0 | 0 | 0 | 1 | | |

Bits 7:6 BCS1:0

These bits select the magnitude of the sensor burnout detect current source.

00 = Burnout current source off (default)

01 = Burnout current source on, 0.5µA

10 = Burnout current source on, 2µA

11 = Burnout current source on, 10µA

Bits 5:0 These bits must always be set to '000001'.

ADS1246 DETAILED REGISTER DEFINITIONS (continued)

VBIAS—Bias Voltage Register. This register enables a bias voltage on the analog inputs.

| VBIAS - ADDRESS 01h | | | | | | | RESET VALUE = 00h |
|---------------------|-------|-------|-------|-------|-------|--------|-------------------|
| BIT 7 | BIT 6 | BIT 5 | BIT 4 | BIT 3 | BIT 2 | BIT 1 | BIT 0 |
| 0 | 0 | 0 | 0 | 0 | 0 | VBIAS1 | VBIAS0 |

Bits 7:2 These bits must always be set to '000000'.

Bits 1:0 **VBIAS1:0**

These bits apply a bias voltage of midsupply $(AVDD + AVSS)/2$ to the selected analog input. Bit 0 is for AIN0, and bit 1 is for AIN1.

0 = Bias voltage not enabled (default)

1 = Bias voltage is applied to the analog input

MUX—Multiplexer Control Register.

| MUX - ADDRESS 02h | | | | | | | RESET VALUE = x0h |
|-------------------|-------|-------|-------|-------|---------|---------|-------------------|
| BIT 7 | BIT 6 | BIT 5 | BIT 4 | BIT 3 | BIT 2 | BIT 1 | BIT 0 |
| CLKSTAT | 0 | 0 | 0 | 0 | MUXCAL2 | MUXCAL1 | MUXCAL0 |

Bit 7 **CLKSTAT**

This bit is read-only and indicates whether the internal or external oscillator is being used.

0 = Internal oscillator in use

1 = External oscillator in use

Bits 6:3 These bits must always be set to '0000'.

Bits 2:0 **MUXCAL2:0**

These bits are used to select a system monitor. The MUXCAL selection supercedes selections from the VBIAS register.

000 = Normal operation (default)

001 = Offset calibration. The analog inputs are disconnected and AINP and AINN are internally connected to midsupply $(AVDD + AVSS)/2$.

010 = Gain calibration. The analog inputs are connected to the voltage reference.

011 = Temperature measurement. The inputs are connected to a diode circuit that produces a voltage proportional to the ambient temperature of the device..

[Table 18](#) lists the ADC input connection and PGA settings for each MUXCAL setting. The PGA setting reverts to the original SYS0 register setting when MUXCAL is taken back to normal operation or offset measurement.

Table 18. MUXCAL Settings

| MUXCAL[2:0] | PGA GAIN SETTING | ADC INPUT |
|-------------|----------------------|---|
| 000 | Set by SYS0 register | Normal operation |
| 001 | Set by SYS0 register | Offset calibration: inputs shorted to midsupply $(AVDD + AVSS)/2$ |
| 010 | Forced to 1 | Gain calibration: $V_{REFP} - V_{REFN}$ (full-scale) |
| 011 | Forced to 1 | Temperature measurement diode |

ADS1246 DETAILED REGISTER DEFINITIONS (continued)

SYS0—System Control Register 0.

| SYS0 - ADDRESS 03h | | | | | | | RESET VALUE = 00h |
|--------------------|-------|-------|-------|-------|-------|-------|-------------------|
| BIT 7 | BIT 6 | BIT 5 | BIT 4 | BIT 3 | BIT 2 | BIT 1 | BIT 0 |
| 0 | PGA2 | PGA1 | PGA0 | DOR3 | DOR2 | DOR1 | DOR0 |

Bit 7 **These bits must always be set to '0'.**

Bits 6:4 **PGA2:0**

These bits determine the gain of the PGA.

000 = 1 (default)

001 = 2

010 = 4

011 = 8

100 = 16

101 = 32

110 = 64

111 = 128

Bits 3:0 **DOR3:0**

These bits select the output data rate of the ADC. Bits with a value higher than 1001 select the highest data rate of 2000SPS.

0000 = 5SPS (default)

0001 = 10SPS

0010 = 20SPS

0011 = 40SPS

0100 = 80SPS

0101 = 160SPS

0110 = 320SPS

0111 = 640SPS

1000 = 1000SPS

1001 to 1111 = 2000SPS

OFC0—Offset Calibration Coefficient Register 0

| OFC0 - ADDRESS 04h | | | | | | | RESET VALUE = 00h |
|--------------------|-------|-------|-------|-------|-------|-------|-------------------|
| BIT 7 | BIT 6 | BIT 5 | BIT 4 | BIT 3 | BIT 2 | BIT 1 | BIT 0 |
| OFC7 | OFC6 | OFC5 | OFC4 | OFC3 | OFC2 | OFC1 | OFC0 |

OFC1—Offset Calibration Coefficient Register 1

| OFC1 - ADDRESS 05h | | | | | | | RESET VALUE = 00h |
|--------------------|-------|-------|-------|-------|-------|-------|-------------------|
| BIT 7 | BIT 6 | BIT 5 | BIT 4 | BIT 3 | BIT 2 | BIT 1 | BIT 0 |
| OFC15 | OFC14 | OFC13 | OFC12 | OFC11 | OFC10 | OFC9 | OFC8 |

OFC2—Offset Calibration Coefficient Register 2

| OFC2 - ADDRESS 06h | | | | | | | RESET VALUE = 00h |
|--------------------|-------|-------|-------|-------|-------|-------|-------------------|
| BIT 7 | BIT 6 | BIT 5 | BIT 4 | BIT 3 | BIT 2 | BIT 1 | BIT 0 |
| OFC23 | OFC22 | OFC21 | OFC20 | OFC19 | OFC18 | OFC17 | OFC16 |

OFC23:0

These bits make up the offset calibration coefficient register of the ADS1248. The default value is either 000h or the trim value.

ADS1246 DETAILED REGISTER DEFINITIONS (continued)
FSC0—Full-Scale Calibration Coefficient Register 0

| FSC0 - ADDRESS 07h | | | | RESET VALUE = 00h or Trim Value | | | |
|--------------------|-------|-------|-------|---------------------------------|-------|-------|-------|
| BIT 7 | BIT 6 | BIT 5 | BIT 4 | BIT 3 | BIT 2 | BIT 1 | BIT 0 |
| FSC7 | FSC6 | FSC5 | FSC4 | FSC3 | FSC2 | FSC1 | FSC0 |

FSC1—Full-Scale Calibration Coefficient Register 1

| FSC1 - ADDRESS 08h | | | | RESET VALUE = 00h or Trim Value | | | |
|--------------------|-------|-------|-------|---------------------------------|-------|-------|-------|
| BIT 7 | BIT 6 | BIT 5 | BIT 4 | BIT 3 | BIT 2 | BIT 1 | BIT 0 |
| FSC15 | FSC14 | FSC13 | FSC12 | FSC11 | FSC10 | FSC9 | FSC8 |

FSC2—Full-Scale Calibration Coefficient Register 2

| FSC2 - ADDRESS 09h | | | | RESET VALUE = 40h or Trim Value | | | |
|--------------------|-------|-------|-------|---------------------------------|-------|-------|-------|
| BIT 7 | BIT 6 | BIT 5 | BIT 4 | BIT 3 | BIT 2 | BIT 1 | BIT 0 |
| FSC23 | FSC22 | FSC21 | FSC20 | FSC19 | FSC18 | FSC17 | FSC16 |

FSC23:0

These bits make up the full-scale calibration coefficient register. The default for this register is a full-scale calibration at a gain of 32.

ID—ID Register

| IDAC0 - ADDRESS 0Ah | | | | RESET VALUE = x0h | | | |
|---------------------|-------|-------|-------|-------------------|-------|-------|-------|
| BIT 7 | BIT 6 | BIT 5 | BIT 4 | BIT 3 | BIT 2 | BIT 1 | BIT 0 |
| ID3 | ID2 | ID1 | ID0 | DRDY MODE | 0 | 0 | 0 |

Bits 7:4
ID3:0

Read-only, factory-programmed bits; used for revision identification.

Bit 3
DRDY MODE

This bit sets the DOUT/ $\overline{\text{DRDY}}$ pin functionality. In either setting of the DRDY MODE bit, the $\overline{\text{DRDY}}$ pin continues to indicate data ready, active low.

0 = DOUT/ $\overline{\text{DRDY}}$ pin functions only as Data Out (default)

1 = DOUT/ $\overline{\text{DRDY}}$ pin functions both as Data Out and Data Ready, active low

Bits 2:0

These bits must always be set to '000'.

ADS1247 AND ADS1248 REGISTER MAP

Table 19. ADS1247/48 Register Map

| ADDRESS | REGISTER | BIT 7 | BIT 6 | BIT 5 | BIT 4 | BIT 3 | BIT 2 | BIT 1 | BIT 0 |
|---------|----------|---------|----------|----------|----------|--------------|---------|---------|---------|
| 00h | MUX0 | BCS1 | BCS0 | MUX_SP2 | MUX_SP1 | MUX_SP0 | MUX_SN2 | MUX_SN1 | MUX_SN0 |
| 01h | VBIAS | VBIAS7 | VBIAS6 | VBIAS5 | VBIAS4 | VBIAS3 | VBIAS2 | VBIAS1 | VBIAS0 |
| 02h | MUX1 | CLKSTAT | VREFCON1 | VREFCON0 | REFSELT1 | REFSELT0 | MUXCAL2 | MUXCAL1 | MUXCAL0 |
| 03h | SYS0 | 0 | PGA2 | PGA1 | PGA0 | DR3 | DR2 | DR1 | DR0 |
| 04h | OFC0 | OFC7 | OFC6 | OFC5 | OFC4 | OFC3 | OFC2 | OFC1 | OFC0 |
| 05h | OFC1 | OFC15 | OFC14 | OFC13 | OFC12 | OFC11 | OFC10 | OFC9 | OFC8 |
| 06h | OFC2 | OFC23 | OFC22 | OFC21 | OFC20 | OFC19 | OFC18 | OFC17 | OFC16 |
| 07h | FSC0 | FSC7 | FSC6 | FSC5 | FSC4 | FSC3 | FSC2 | FSC1 | FSC0 |
| 08h | FSC1 | FSC15 | FSC14 | FSC13 | FSC12 | FSC11 | FSC10 | FSC9 | FSC8 |
| 09h | FSC2 | FSC23 | FSC22 | FSC21 | FSC20 | FSC19 | FSC18 | FSC17 | FSC16 |
| 0Ah | IDAC0 | ID3 | ID2 | ID1 | ID0 | DRDY MODE | IMAG2 | IMAG1 | IMAG0 |
| 0Bh | IDAC1 | I1DIR3 | I1DIR2 | I1DIR1 | I1DIR0 | I2DIR3 | I2DIR2 | I2DIR1 | I2DIR0 |
| 0Ch | GPIOCFG | IOCFG7 | IOCFG6 | IOCFG5 | IOCFG4 | IOCFG3 | IOCFG2 | IOCFG1 | IOCFG0 |
| 0Dh | GPIODIR | IODIR7 | IODIR6 | IODIR5 | IODIR4 | IODIR3 | IODIR2 | IODIR1 | IODIR0 |
| 0Eh | GPIODAT | IODAT7 | IODAT6 | IODAT5 | IODAT4 | IODAT3 | IODAT2 | IODAT1 | IODAT0 |

ADS1247/ADS1248 DETAILED REGISTER DEFINITIONS

MUX0—Multiplexer Control Register 0. This register allows any combination of differential inputs to be selected on any of the input channels. Note that this setting can be superseded by the MUXCAL and VBIAS bits.

| MUX0 - ADDRESS 00h | | | | | | | RESET VALUE = 01h | |
|--------------------|-------|---------|---------|---------|---------|---------|-------------------|--|
| BIT 7 | BIT 6 | BIT 5 | BIT 4 | BIT 3 | BIT 2 | BIT 1 | BIT 0 | |
| BCS1 | BCS0 | MUX_SP2 | MUX_SP1 | MUX_SP0 | MUX_SN2 | MUX_SN1 | MUX_SNO | |

Bits 7:6 BCS1:0

These bits select the magnitude of the sensor detect current source.

00 = Burnout current source off (default)

01 = Burnout current source on, 0.5 μ A

10 = Burnout current source on, 2 μ A

11 = Burnout current source on, 10 μ A

Bits 5:3 MUX_SP2:0

Positive input channel selection bits.

000 = AIN0 (default)

001 = AIN1

010 = AIN2

011 = AIN3

100 = AIN4 (ADS1248 only)

101 = AIN5 (ADS1248 only)

110 = AIN6 (ADS1248 only)

111 = AIN7 (ADS1248 only)

Bits 2:0 MUX_SN2:0

Negative input channel selection bits.

000 = AIN0

001 = AIN1 (default)

010 = AIN2

011 = AIN3

100 = AIN4 (ADS1248 only)

101 = AIN5 (ADS1248 only)

110 = AIN6 (ADS1248 only)

111 = AIN7 (ADS1248 only)

VBIAS—Bias Voltage Register

| VBIAS - ADDRESS 01h | | | | | | | RESET VALUE = 00h | |
|---------------------|--------|--------|--------|--------|--------|--------|-------------------|--------|
| DEVICE | BIT 7 | BIT 6 | BIT 5 | BIT 4 | BIT 3 | BIT 2 | BIT 1 | BIT 0 |
| ADS1248 | VBIAS7 | VBIAS6 | VBIAS5 | VBIAS4 | VBIAS3 | VBIAS2 | VBIAS1 | VBIAS0 |
| ADS1247 | 0 | 0 | 0 | 0 | VBIAS3 | VBIAS2 | VBIAS1 | VBIAS0 |

Bits 7:0 VBIAS7:0

These bits apply a bias voltage of midsupply $(AVDD + AVSS)/2$ to the selected analog input.

0 = Bias voltage not enabled (default)

1 = Bias voltage is applied on the corresponding analog input (bit 0 corresponds to AIN0, etc.).

ADS1247/ADS1248 DETAILED REGISTER DEFINITIONS (continued)

MUX1—Multiplexer Control Register 1

| MUX1 - ADDRESS 02h | | | | | | | RESET VALUE = 00h |
|--------------------|----------|----------|----------|----------|---------|---------|-------------------|
| BIT 7 | BIT 6 | BIT 5 | BIT 4 | BIT 3 | BIT 2 | BIT 1 | BIT 0 |
| CLKSTAT | VREFCON1 | VREFCON0 | REFSELT1 | REFSELT0 | MUXCAL2 | MUXCAL1 | MUXCAL0 |

Bit 7 CLKSTAT

This bit is read-only and indicates whether the internal or external oscillator is being used.
0 = Internal oscillator in use
1 = External oscillator in use

Bits 6:5 VREFCON1:0

These bits control the internal voltage reference. These bits allow the reference to be turned on or off completely, or allow the reference state to follow the state of the device. Note that the internal reference is required for operation of the IDAC functions.
00 = Internal reference is always off (default)
01 = Internal reference is always on
10 or 11 = Internal reference is on when a conversion is in progress and shuts down when the device receives a shutdown opcode or the START pin is taken low

Bits 4:3 REFSELT1:0

These bits select the reference input for the ADC.
00 = REF0 input pair selected (default)
01 = REF1 input pair selected (ADS1248 only)
10 = Onboard reference selected
11 = Onboard reference selected and internally connected to REF0 input pair

Bits 2:0 MUXCAL2:0

These bits are used to select a system monitor. The MUXCAL selection supercedes selections from registers MUX0 and MUX1 (MUX_SP, MUX_SN, and VBIAS).
000 = Normal operation (default)
001 = Offset measurement
010 = Gain measurement
011 = Temperature diode
100 = External REF1 measurement
101 = External REF0 measurement
110 = AVDD measurement
111 = DVDD measurement

Table 20 provides the ADC input connection and PGA settings for each MUXCAL setting. The PGA setting reverts to the original SYS0 register setting when MUXCAL is taken back to normal operation or offset measurement.

Table 20. MUXCAL Settings

| MUXCAL[2:0] | PGA GAIN SETTING | ADC INPUT |
|-------------|----------------------|---|
| 000 | Set by SYS0 register | Normal operation |
| 001 | Set by SYS0 register | Inputs shorted to midsupply (AVDD + AVSS)/2 |
| 010 | Forced to 1 | $V_{REFP} - V_{REFN}$ (full-scale) |
| 011 | Forced to 1 | Temperature measurement diode |
| 100 | Forced to 1 | $(V_{REFP1} - V_{REFN1})/4$ |
| 101 | Forced to 1 | $(V_{REFP0} - V_{REFN0})/4$ |
| 110 | Forced to 1 | $(AVDD - AVSS)/4$ |
| 111 | Forced to 1 | $(DVDD - DVSS)/4$ |

ADS1247/ADS1248 DETAILED REGISTER DEFINITIONS (continued)
SYS0—System Control Register 0

| SYS0 - ADDRESS 03h | | | | | | | RESET VALUE = 00h |
|--------------------|-------|-------|-------|-------|-------|-------|-------------------|
| BIT 7 | BIT 6 | BIT 5 | BIT 4 | BIT 3 | BIT 2 | BIT 1 | BIT 0 |
| 0 | PGA2 | PGA1 | PGA0 | DOR3 | DOR2 | DOR1 | DOR0 |

Bit 7 This bit must always be set to '0'

Bits 6:4 **PGA2:0**

These bits determine the gain of the PGA.

000 = 1 (default)

001 = 2

010 = 4

011 = 8

100 = 16

101 = 32

110 = 64

111 = 128

Bits 3:0 **DOR3:0**

These bits select the output data rate of the ADC. Bits with a value higher than 1001 select the highest data rate of 2000SPS.

0000 = 5SPS (default)

0001 = 10SPS

0010 = 20SPS

0011 = 40SPS

0100 = 80SPS

0101 = 160SPS

0110 = 320SPS

0111 = 640SPS

1000 = 1000SPS

1001 to 1111 = 2000SPS

OFC0—Offset Calibration Coefficient Register 0

| OFC0 - ADDRESS 04h | | | | | | | RESET VALUE = 000000h |
|--------------------|-------|-------|-------|-------|-------|-------|-----------------------|
| BIT 7 | BIT 6 | BIT 5 | BIT 4 | BIT 3 | BIT 2 | BIT 1 | BIT 0 |
| OFC7 | OFC6 | OFC5 | OFC4 | OFC3 | OFC2 | OFC1 | OFC0 |

OFC1—Offset Calibration Coefficient Register 1

| OFC1 - ADDRESS 05h | | | | | | | RESET VALUE = 000000h |
|--------------------|-------|-------|-------|-------|-------|-------|-----------------------|
| BIT 7 | BIT 6 | BIT 5 | BIT 4 | BIT 3 | BIT 2 | BIT 1 | BIT 0 |
| OFC15 | OFC14 | OFC13 | OFC12 | OFC11 | OFC10 | OFC9 | OFC8 |

OFC2—Offset Calibration Coefficient Register 2

| OFC2 - ADDRESS 06h | | | | | | | RESET VALUE = 000000h |
|--------------------|-------|-------|-------|-------|-------|-------|-----------------------|
| BIT 7 | BIT 6 | BIT 5 | BIT 4 | BIT 3 | BIT 2 | BIT 1 | BIT 0 |
| OFC23 | OFC22 | OFC21 | OFC20 | OFC19 | OFC18 | OFC17 | OFC16 |

OFC23:0

These bits make up the offset calibration coefficient register of the ADS1248. The default value is 000h.

ADS1247/ADS1248 DETAILED REGISTER DEFINITIONS (continued)

FSC0—Full-Scale Calibration Coefficient Register 0

| FSC0 - ADDRESS 07h | | | | RESET VALUE = 00h or Trim Value | | | |
|--------------------|-------|-------|-------|---------------------------------|-------|-------|-------|
| BIT 7 | BIT 6 | BIT 5 | BIT 4 | BIT 3 | BIT 2 | BIT 1 | BIT 0 |
| FSC7 | FSC6 | FSC5 | FSC4 | FSC3 | FSC2 | FSC1 | FSC0 |

FSC1—Full-Scale Calibration Coefficient Register 1

| FSC1 - ADDRESS 08h | | | | RESET VALUE = 00h or Trim Value | | | |
|--------------------|-------|-------|-------|---------------------------------|-------|-------|-------|
| BIT 7 | BIT 6 | BIT 5 | BIT 4 | BIT 3 | BIT 2 | BIT 1 | BIT 0 |
| FSC15 | FSC14 | FSC13 | FSC12 | FSC11 | FSC10 | FSC9 | FSC8 |

FSC2—Full-Scale Calibration Coefficient Register 2

| FSC2 - ADDRESS 09h | | | | RESET VALUE = 40h or Trim Value | | | |
|--------------------|-------|-------|-------|---------------------------------|-------|-------|-------|
| BIT 7 | BIT 6 | BIT 5 | BIT 4 | BIT 3 | BIT 2 | BIT 1 | BIT 0 |
| FSC23 | FSC22 | FSC21 | FSC20 | FSC19 | FSC18 | FSC17 | FSC16 |

FSC23:0

These bits make up the full-scale calibration coefficient register. The default for this register is a full-scale calibration at a gain of 32.

IDAC0—IDAC Control Register 0

| IDAC0 - ADDRESS 0Ah | | | | RESET VALUE = x0h | | | |
|---------------------|-------|-------|-------|-------------------|-------|-------|-------|
| BIT 7 | BIT 6 | BIT 5 | BIT 4 | BIT 3 | BIT 2 | BIT 1 | BIT 0 |
| ID3 | ID2 | ID1 | ID0 | DRDY MODE | IMAG2 | IMAG1 | IMAG0 |

Bits 7:4 ID3:0

Read-only, factory-programmed bits; used for revision identification.

Bit 3 DRDY MODE

This bit sets the $\overline{\text{DOUT/DRDY}}$ pin functionality. In either setting of the DRDY MODE bit, the $\overline{\text{DRDY}}$ pin continues to indicate data ready, active low.

0 = $\overline{\text{DOUT/DRDY}}$ pin functions only as Data Out (default)

1 = $\overline{\text{DOUT/DRDY}}$ pin functions both as Data Out and Data Ready, active low

Bits 2:0 IMAG2:0

The ADS1247/48 have two programmable current source DACs that can be used for sensor excitation. The IMAG bits control the magnitude of the excitation current. The IDACs require the internal reference to be on.

000 = off (default)

001 = 50 μ A

010 = 100 μ A

011 = 250 μ A

100 = 500 μ A

101 = 750 μ A

110 = 1000 μ A

111 = 1500 μ A

ADS1247/ADS1248 DETAILED REGISTER DEFINITIONS (continued)
IDAC1—IDAC Control Register 1

| IDAC1 - ADDRESS 0Bh | | | | | | | RESET VALUE = FFh | |
|---------------------|--------|--------|--------|--------|--------|--------|-------------------|--------|
| DEVICE | BIT 7 | BIT 6 | BIT 5 | BIT 4 | BIT 3 | BIT 2 | BIT 1 | BIT 0 |
| ADS1248 | I1DIR3 | I1DIR2 | I1DIR1 | I1DIR0 | I2DIR3 | I2DIR2 | I2DIR1 | I2DIR0 |
| ADS1247 | 0 | 0 | I1DIR1 | I1DIR0 | 0 | 0 | I2DIR1 | I2DIR0 |

The two IDACs on the ADS1247/48 can be routed to either the IEXC1 and IEXC2 output pins or directly to the analog inputs.

Bits 7:4 I1DIR3:0

These bits select the output pin for the first current source DAC.

0000 = AIN0

0001 = AIN1

0010 = AIN2

0011 = AIN3

0100 = AIN4

0101 = AIN5 (ADS1248 only)

0110 = AIN6 (ADS1248 only)

0111 = AIN7 (ADS1248 only)

10x0 = IEXT1 (ADS1248 only)

10x1 = IEXT2 (ADS1248 only)

11xx = Disconnected (default)

Bits 3:0 I2DIR3:0

These bits select the output pin for the second current source DAC.

0000 = AIN0

0001 = AIN1

0010 = AIN2

0011 = AIN3

0100 = AIN4 (ADS1248 only)

0101 = AIN5 (ADS1248 only)

0110 = AIN6 (ADS1248 only)

0111 = AIN7 (ADS1248 only)

10x0 = IEXT1 (ADS1248 only)

10x1 = IEXT2 (ADS1248 only)

11xx = Disconnected (default)

ADS1247/ADS1248 DETAILED REGISTER DEFINITIONS (continued)

GPIOCFG—GPIO Configuration Register. The GPIO and analog pins are shared as follows:

- GPIO0 shared with REFP0
- GPIO1 shared with REFN0
- GPIO2 shared with AIN2
- GPIO3 shared with AIN3
- GPIO4 shared with AIN4 (ADS1248)
- GPIO5 shared with AIN5 (ADS1248)
- GPIO6 shared with AIN6 (ADS1248)
- GPIO7 shared with AIN7 (ADS1248)

| GPIOCFG - ADDRESS 0Ch | | | | | | | | RESET VALUE = 00h |
|-----------------------|--------|--------|--------|--------|--------|--------|--------|-------------------|
| DEVICE | BIT 7 | BIT 6 | BIT 5 | BIT 4 | BIT 3 | BIT 2 | BIT 1 | BIT 0 |
| ADS1248 | IOCFG7 | IOCFG6 | IOCFG5 | IOCFG4 | IOCFG3 | IOCFG2 | IOCFG1 | IOCFG0 |
| ADS1247 | 0 | 0 | 0 | 0 | IOCFG3 | IOCFG2 | IOCFG1 | IOCFG0 |

Bits 7:0 IOCFG7:0

These bits enable the GPIO because the GPIO pins are shared with the analog pins. Note that the ADS1248 uses all the IOCFG bits, whereas the ADS1247 uses only bits 3:0.
 0 = The pin is used as an analog input (default)
 1 = The pin is used as a GPIO pin

GPIODIR—GPIO Direction Register

| GPIODIR - ADDRESS 0Dh | | | | | | | | RESET VALUE = 00h |
|-----------------------|--------|--------|--------|--------|--------|--------|--------|-------------------|
| DEVICE | BIT 7 | BIT 6 | BIT 5 | BIT 4 | BIT 3 | BIT 2 | BIT 1 | BIT 0 |
| ADS1248 | IODIR7 | IODIR6 | IODIR5 | IODIR4 | IODIR3 | IODIR2 | IODIR1 | IODIR0 |
| ADS1247 | 0 | 0 | 0 | 0 | IODIR3 | IODIR2 | IODIR1 | IODIR0 |

Bits 7:0 IODIR7:0

These bits control the direction of the GPIO when enabled by the IOCFG bits. Note that the ADS1248 uses all the IODIR bits, whereas the ADS1247 uses only bits 3:0.
 0 = The GPIO is an output (default)
 1 = The GPIO is an input

GPIODAT—GPIO Data Register

| GPIODAT - ADDRESS 0Eh | | | | | | | | RESET VALUE = 00h |
|-----------------------|--------|--------|--------|--------|--------|--------|--------|-------------------|
| DEVICE | BIT 7 | BIT 6 | BIT 5 | BIT 4 | BIT 3 | BIT 2 | BIT 1 | BIT 0 |
| ADS1248 | IODAT7 | IODAT6 | IODAT5 | IODAT4 | IODAT3 | IODAT2 | IODAT1 | IODAT0 |
| ADS1247 | 0 | 0 | 0 | 0 | IODAT3 | IODAT2 | IODAT1 | IODAT0 |

Bits 7:0 IODAT7:0

If a GPIO pin is enabled in the GPIOCFG register and configured as an output in the GPIO Direction register (GPIODIR), the value written to this register appears on the appropriate GPIO pin. If a GPIO pin is configured as an input in GPIODIR, reading this register returns the value of the digital I/O pins. Note that the ADS1248 uses all eight IODAT bits, while the ADS1247 uses only bits 3:0.

SPI COMMANDS

SPI COMMAND DEFINITIONS

The commands shown in [Table 21](#) control the operation of the ADS1246/47/48. Some of the commands are stand-alone commands (for example, RESET), whereas others require additional bytes (for example, WREG requires command, count, and the data bytes).

Operands:

n = number of registers to be read or written (number of bytes – 1)

r = register (0 to 15)

x = don't care

Table 21. SPI Commands

| COMMAND TYPE | COMMAND | DESCRIPTION | 1st COMMAND BYTE | 2nd COMMAND BYTE |
|----------------|----------|--------------------------------|------------------------|--------------------|
| System Control | WAKEUP | Exit sleep mode | 0000 000x (00h, 01h) | |
| | SLEEP | Enter sleep mode | 0000 001x (02h, 03h) | |
| | SYNC | Synchronize the A/D conversion | 0000 010x (04h, 05h) | 0000-010x (04,05h) |
| | RESET | Reset to power-up values | 0000 011x (06h, 07h) | |
| | PO INIT | Power-on initialization | 0000 111x (0Eh, 0Fh) | |
| | NOP | No operation | 1111 1111 (FFh) | |
| Data Read | RDATA | Read data once | 0001 001x (12h, 13h) | |
| | RDATAc | Read data continuously | 0001 010x (14h, 15h) | |
| | SDATAc | Stop reading data continuously | 0001 011x (16h, 17h) | |
| Read Register | RREG | Read from register <i>rrrr</i> | 0010 <i>rrrr</i> (2xh) | 0000_ <i>nnnn</i> |
| Write Register | WREG | Write to register <i>rrrr</i> | 0100 <i>rrrr</i> (4xh) | 0000_ <i>nnnn</i> |
| Calibration | YSOCAL | System offset calibration | 0110 0000 (60h) | |
| | YSGCAL | System gain calibration | 0110 0001 (61h) | |
| | SELFOCAL | Self offset calibration | 0110 0010 (62h) | |

SYSTEM CONTROL COMMANDS

WAKEUP—Wake up from sleep mode that is set by the SLEEP command.

Use this command to awaken the device from sleep mode. After execution of the WAKEUP command, the device wakes up on the rising edge of the eighth SCLK.

SLEEP—Set the device to sleep mode; can only be awakened by the WAKEUP command.

This command places the part into a sleep (power-saving) mode. When the SLEEP command is issued, the device completes the current conversion and then goes into sleep mode. Note that this command does not automatically power-down the internal voltage reference; see the VREFCON bits in the MUX1 register for each device for further details.

To exit sleep mode, issue the WAKEUP command. Single conversions can be performed by issuing a WAKEUP command followed by a SLEEP command.

Both WAKEUP and SLEEP are the software command equivalents of using the START pin to control the device.

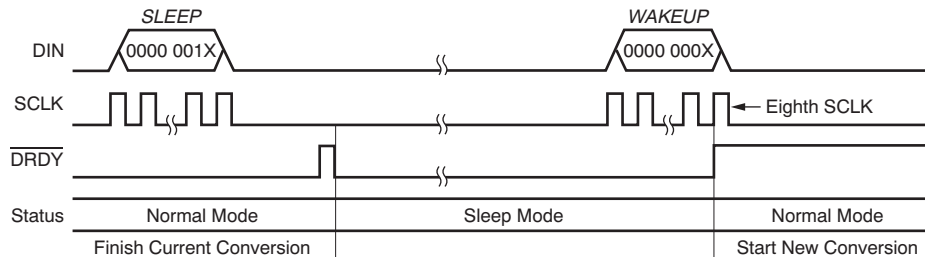

Figure 52. SLEEP and WAKEUP Commands Operation

SYNC—Synchronize $\overline{\text{DRDY}}$.

This command resets the ADC digital filter and starts a new conversion. The $\overline{\text{DRDY}}$ pin from multiple devices connected to the same SPI bus can be synchronized by issuing a SYNC command to all of devices simultaneously.

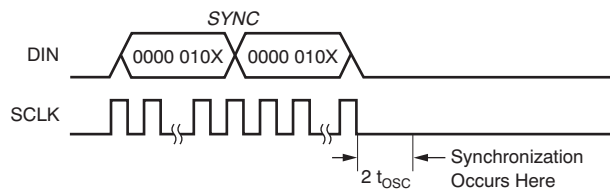

Figure 53. SYNC Command Operation

RESET—Reset the device to power-up state.

This command restores the registers to the respective power-up values. This command also resets the digital filter. RESET is the command equivalent of using the RESET pin to reset the device. However, the RESET command does not reset the SPI interface. If the RESET command is issued when the SPI interface is in the wrong state, the device will not reset. The $\overline{\text{CS}}$ pin can be used to reset SPI interface first, and then a RESET command can be issued to reset the device. The RESET command holds the registers and the decimation filter in a reset state for 0.6ms when the system clock frequency is 4.096MHz, similar to the hardware reset. Therefore, SPI communication can be only be started 0.6ms after the RESET command is issued, as shown in Figure 54.

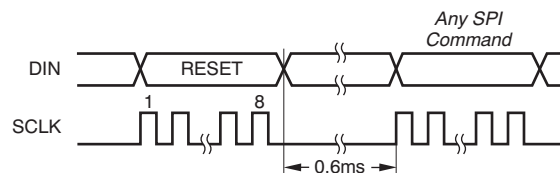

Figure 54. SPI Communication After an SPI Reset

PO INIT—Initialize the device.

This command must be sent after power-up or recovery from a power-supply brownout (dropout) condition.

This command is not required when using the $\overline{\text{RESET}}$ pin.

Figure 55 illustrates the required delays.

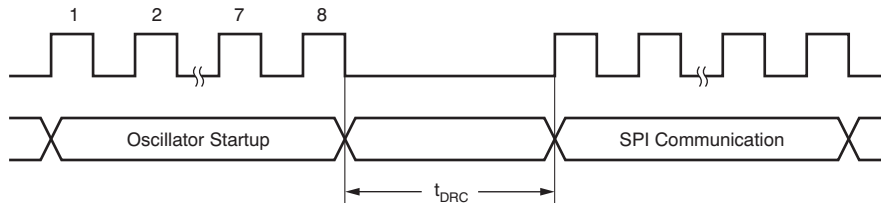

Figure 55. PO INIT Timing

Table 22. Oscillator Startup Time

| SYMBOL | DESCRIPTION | MIN | MAX | UNIT |
|------------------|----------------------------------|-----|-----|------|
| t_{DRC} | Time to resume SPI communication | 10 | | ms |

DATA RETRIEVAL COMMANDS

RDATAAC—Read data continuously.

The RDATAAC command enables the automatic loading of a new conversion result into the output data register. In this mode, the conversion result can be received once from the device after the $\overline{\text{DRDY}}$ signal goes low by sending 24 SCLKs. It is not necessary to read back all the bits, as long as the number of bits read out is a multiple of eight. The RDATAAC command must be issued after $\overline{\text{DRDY}}$ goes low, and the command takes effect on the next $\overline{\text{DRDY}}$.

Be sure to complete data retrieval (conversion result or register read-back) before $\overline{\text{DRDY}}$ goes low, or the resulting data will be corrupt. Successful register read operations in RDATAAC mode require the knowledge of when the next $\overline{\text{DRDY}}$ falling edge will occur.

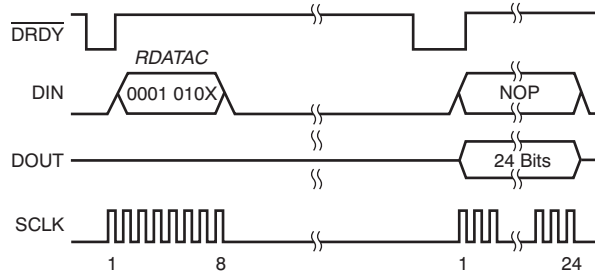

Figure 56. Read Data Continuously

SDATAC—Stop reading data continuously.

The SDATAC command terminates the RDATAAC mode. Afterwards, the conversion result is not automatically loaded into the output shift register when $\overline{\text{DRDY}}$ goes low, and register read operations can be performed without interruption from new conversion results being loaded into the output shift register. Use the RDATA command to retrieve conversion data. The SDATAC command takes effect after the next $\overline{\text{DRDY}}$.

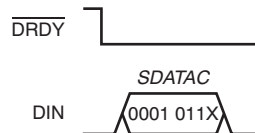

Figure 57. Stop Reading Data Continuously

RDATA—Read data once.

The RDATA command loads the most recent conversion result into the output register. After issuing this command, the conversion result can be read out by sending 24 SCLKs, as shown in Figure 58. This command also works in RDATA mode.

When performing multiple reads of the conversion result, the RDATA command can be sent when the last eight bits of the conversion result are being shifted out during the course of the first read operation by taking advantage of the duplex communication nature of the SPI interface, as shown in Figure 59.

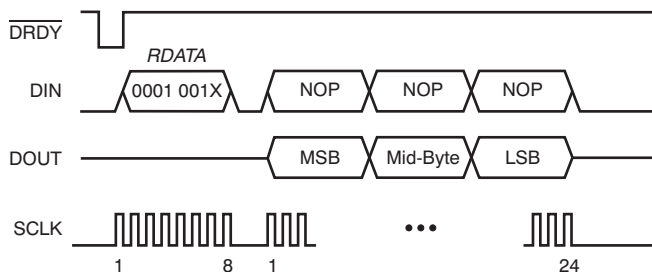

Figure 58. Read Data Once

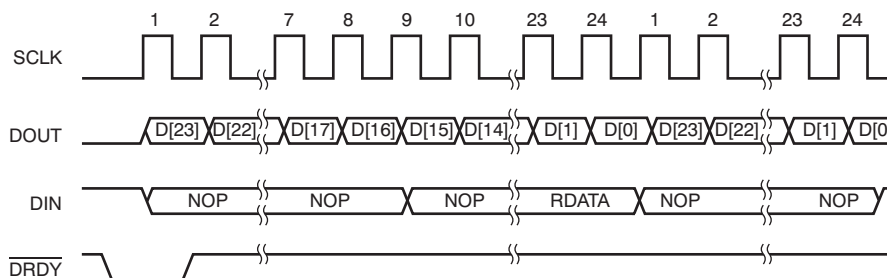

Figure 59. Using RDATA in Full-Duplex Mode

USER REGISTER READ AND WRITE COMMANDS

RREG—Read from registers.

This command outputs the data from up to 16 registers, starting with the register address specified as part of the instruction. The number of registers read is one plus the second byte. If the count exceeds the remaining registers, the addresses wrap back to the beginning.

1st Command Byte: 0010 *rrrr*, where *rrrr* is the address of the first register to read.

2nd Command Byte: 0000 *nnnn*, where *nnnn* is the number of bytes to read – 1.

It is not possible to use the full-duplex nature of the SPI interface when reading out the register data. For example, a SYNC command cannot be issued when reading out the VBIAS and MUX1 data, as shown in [Figure 60](#). Any command sent during the readout of the register data is ignored. Thus, it is advisable to send NOP through the DIN when reading out the register data.

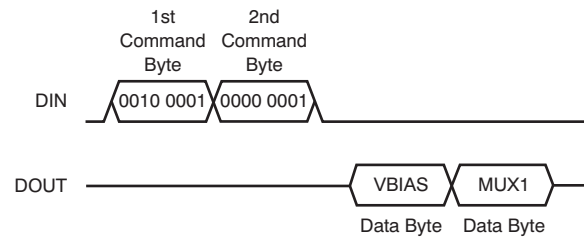

Figure 60. Read from Register

WREG—Write to registers.

This command writes to the registers, starting with the register specified as part of the instruction. The number of registers that are written is one plus the value of the second byte.

1st Command Byte: 0100 *rrrr*, where *rrrr* is the address of the first register to be written.

2nd Command Byte: 0000 *nnnn*, where *nnnn* is the number of bytes to be written – 1.

Data Byte(s): data to be written to the registers.

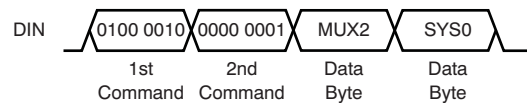

Figure 61. Write to Register

CALIBRATION COMMANDS

The ADS1246/47/48 provide system and offset calibration commands and a system gain calibration command. When calibration is initiated using these commands, the device internally performs 16 consecutive data conversions and calculates the calibration value. The calculated calibration value is stored in the corresponding register. For example, the offset calibration value is stored in the Offset Calibration (OFC) register (default = 000000h) and the gain calibration values is stored in the full-scale calibration (FSC) register (default = 400000h).

SYSOCAL—Offset system calibration.

This command initiates a system offset calibration. For a system offset calibration, the input should be externally set to zero. The OFC register is updated when this operation completes.

SYSGCAL—System gain calibration.

This command initiates the system gain calibration. For a system gain calibration, the input should be set to full-scale. The FSC register is updated after this operation.

SELFOCAL—Self offset calibration.

This command initiates a self-calibration for offset. The device internally shorts the inputs and performs the calibration. The OFC register is updated after this operation.

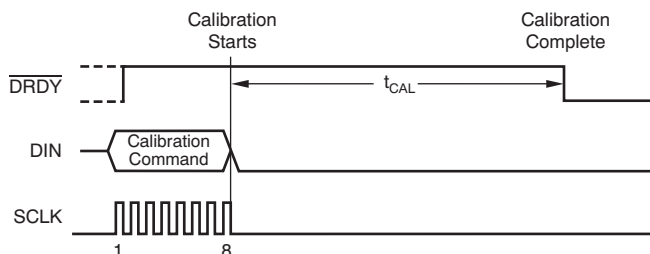

Figure 62. Calibration Command

The calibration time (t_{CAL}) is:

$$t_{CAL} = 32(\text{Modulation Clocks}) + 16(\text{Conversion Time}) + 50(\text{Oscillator Clocks})$$

using the modulation clock frequency is shown in [Table 9](#).

[Table 23](#) shows the calibration time for $f_{OSC} = 4.096\text{MHz}$.

Table 23. Calibration Time for $f_{OSC} = 4.096\text{MHz}$

| DATA RATE (SPS) | TIME TO PERFORM CALIBRATION (ms) |
|-----------------|----------------------------------|
| 5 | 3201.012 |
| 10 | 1601.012 |
| 20 | 801.0122 |
| 40 | 400.2622 |
| 80 | 200.2622 |
| 160 | 100.2622 |
| 320 | 50.13721 |
| 640 | 25.13721 |
| 1000 | 16.13721 |
| 2000 | 8.074707 |

APPLICATION INFORMATION

SPI COMMUNICATION EXAMPLES

This section contains several examples of SPI communication with the ADS1246/7/8, including the power-up sequence.

Channel Multiplexing Example

This first example applies only to the ADS1247 and ADS1248. It explains a method to use the device with two sensors connected to two different analog channels. Figure 63 shows the sequence of SPI operations performed on the device. After power-up, the initial ADC setup cannot be carried out before the power-on reset sequence completes internally after t_{PWOR} . In this example, one of the sensors is connected to channels AIN0 and AIN1 and the other sensor is connected to channels AIN2 and AIN3. The ADC is operated at a data rate of 2kSPS. The PGA gain is set to 32 for both sensors. VBIAS is connected to the negative terminal of both sensors

(that is, channels AIN1 and AIN3). All these settings can be changed by performing a block write operation on the first four registers of the device. After the DRDY pin goes low, the conversion result can be immediately retrieved by sending in 24 SPI clock pulses because the device defaults to RDATA mode. As the conversion result is being retrieved, the active input channels can be switched to AIN2 and AIN3 by writing into the MUX0 register in a full-duplex manner, as shown in Figure 63. The write operation is completed in the same 24 SPI clock pulses. The time from the write operation into the MUX0 register to the next \overline{DRDY} low transition is shown in Figure 63 and is 0.513ms in this case. After \overline{DRDY} goes low, the conversion result can be retrieved and the active channel can be switched as before.

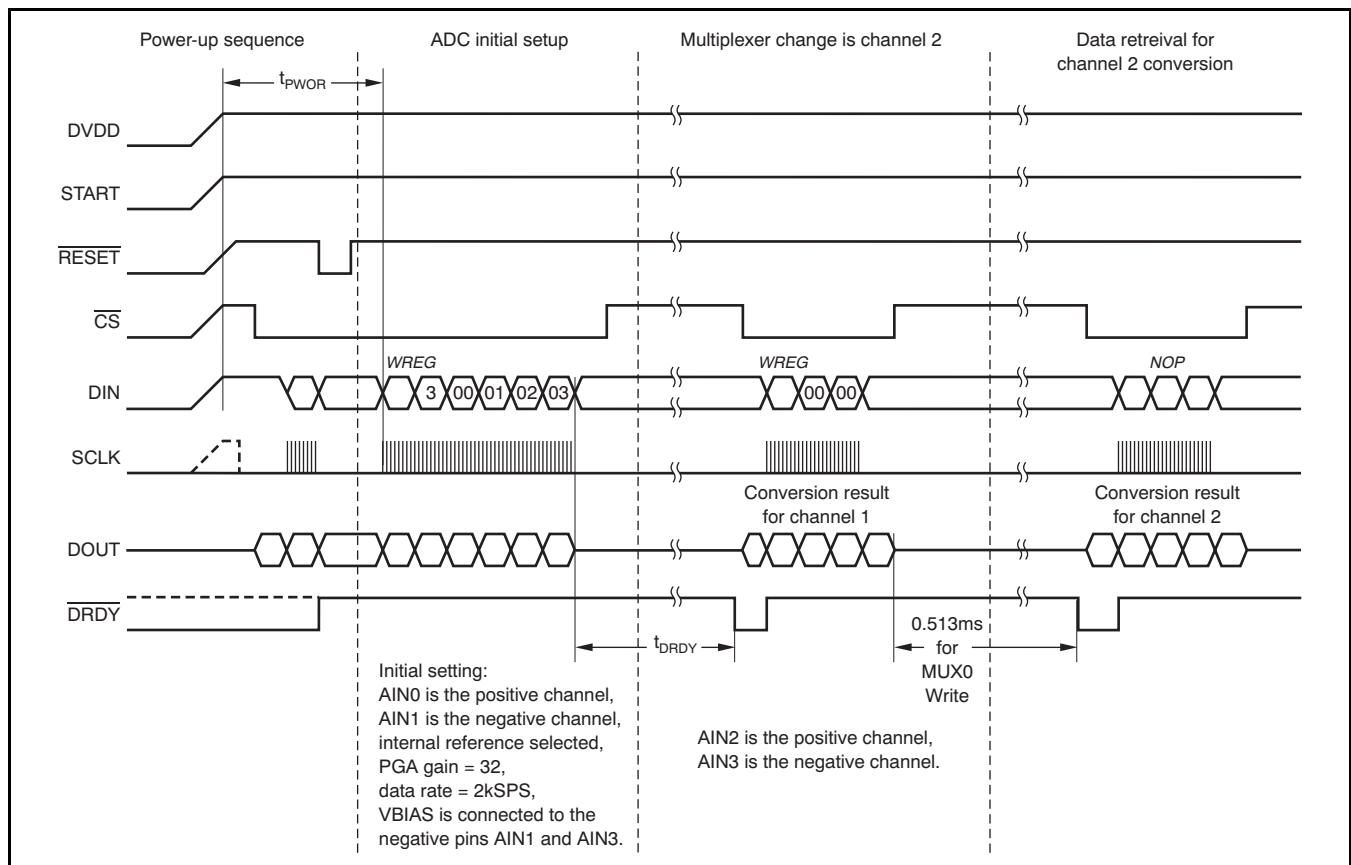

Figure 63. SPI Communication Sequence for Channel Multiplexing

Sleep Mode Example

This second example deals with performing one conversion after power-up and then entering into the power-saving sleep mode. In this example, a sensor is connected to input channels AIN0 and AIN1. After powering up the device with the power-up sequence shown in Figure 64, the commands to setup the ADC are issued after t_{PWOR} . The ADC operates at a data rate of 2kSPS. The PGA gain is set to 32 for both sensors. VBIAS is connected to the negative terminal of both the sensors (that is, channel AIN1). All these

settings can be changed by performing a block write operation on the first four registers of the device. After performing the block write operation, the START pin can be taken low. The device enters the power-saving sleep mode as soon as DRDY goes low 0.575ms after writing into the SYS0 register. The conversion result can be retrieved even after the device enters sleep mode by sending 24 SPI clock pulses.

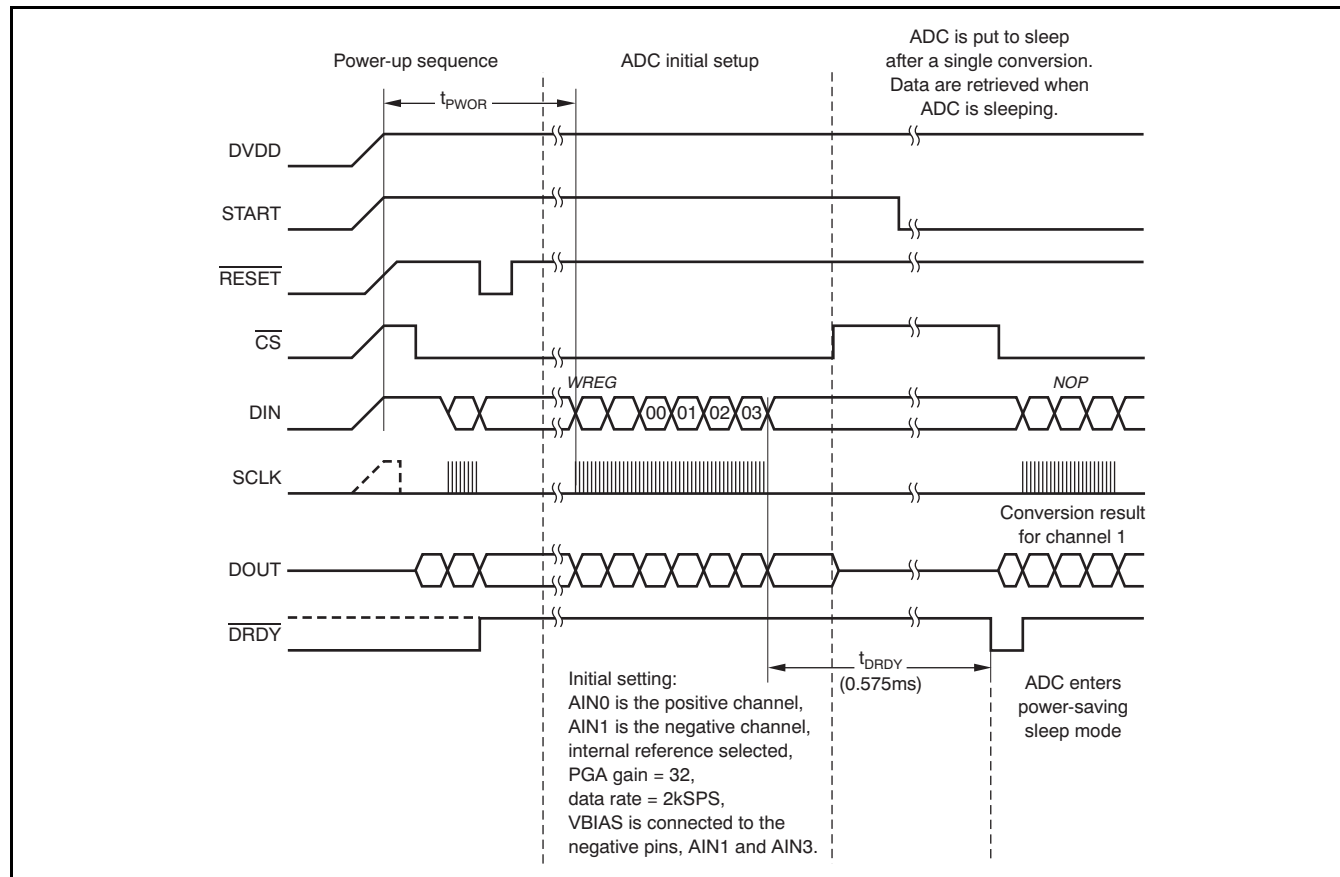

Figure 64. SPI Communication Sequence for Entering Sleep Mode After a Conversion

Hardware-Compensated, Three-Wire RTD Measurement Example

Figure 65 is an application circuit to measure temperatures in the range of 0°C to +50°C using a PT-100 RTD and the ADS1247 or ADS1248 in a three-wire, hardware-compensated topology. The two onboard matched current DACs of the ADS1247/48 are ideally suited for implementing the three-wire RTD topology. This circuit uses a ratiometric approach, where the reference is derived from the IDAC currents in order to achieve excellent noise performance. The resistance of the PT-100 changes from 100Ω at 0°C to 119.6Ω at +50°C. The compensating resistor (R_{COMP}) has been chosen to

be equal to the resistance of the PT-100 sensor at +25°C (approximately 110Ω). The IDAC current is set to 1.5mA. This setting results in a differential input swing of ±14.7mV at the inputs of the ADC. The PGA gain is set to 128. The full-scale input for the ADC is ±19.53mV. Fixing R_{BIAS} at 833Ω fixes the reference at 2.5V and the input common-mode at approximately 2.7V, ensuring that the voltage at AIN0 is far away from the IDAC compliance voltage.

The maximum number of noise-free output codes for this circuit in the 0°C to +50°C temperature range is $(2^{ENOB})(14.7mV)/19.53mV$.

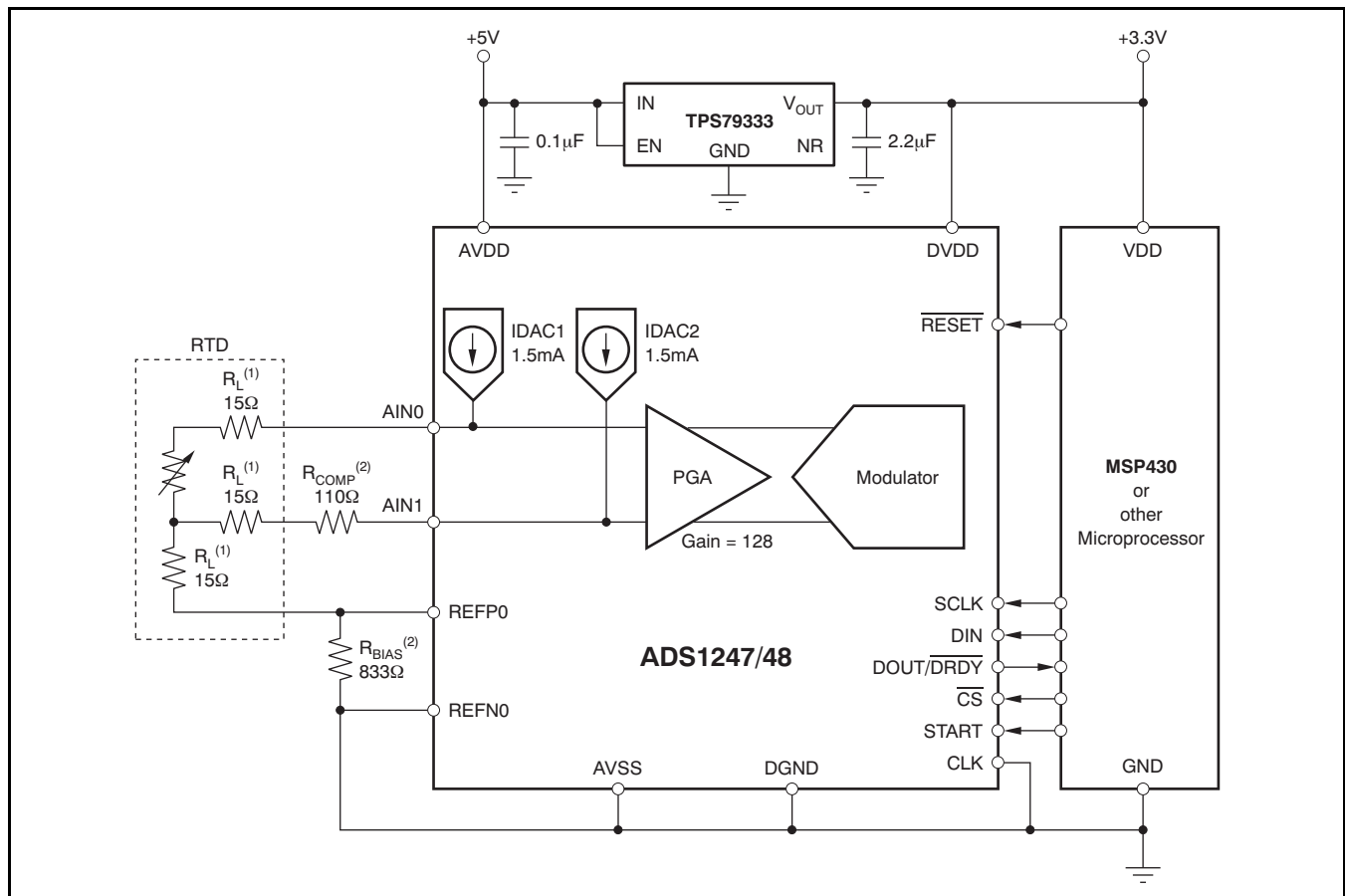

- (1) RTD line resistances.
- (2) R_{BIAS} and R_{COMP} should be as close to the ADC as possible.

Figure 65. Three-Wire RTD Application with Hardware Compensation

PACKAGING INFORMATION

| Orderable Device | Status ⁽¹⁾ | Package Type | Package Drawing | Pins | Package Qty | Eco Plan ⁽²⁾ | Lead/Ball Finish | MSL Peak Temp ⁽³⁾ |
|------------------|-----------------------|--------------|-----------------|------|-------------|-------------------------|------------------|------------------------------|
| ADS1246IPW | ACTIVE | TSSOP | PW | 16 | 90 | Green (RoHS & no Sb/Br) | CU NIPDAU | Level-1-260C-UNLIM |
| ADS1246IPWR | ACTIVE | TSSOP | PW | 16 | 2000 | Green (RoHS & no Sb/Br) | CU NIPDAU | Level-1-260C-UNLIM |
| ADS1247IPW | ACTIVE | TSSOP | PW | 20 | 70 | Green (RoHS & no Sb/Br) | CU NIPDAU | Level-2-260C-1 YEAR |
| ADS1247IPWR | ACTIVE | TSSOP | PW | 20 | 2000 | Green (RoHS & no Sb/Br) | CU NIPDAU | Level-2-260C-1 YEAR |
| ADS1248IPW | ACTIVE | TSSOP | PW | 28 | 50 | Green (RoHS & no Sb/Br) | CU NIPDAU | Level-2-260C-1 YEAR |
| ADS1248IPWR | ACTIVE | TSSOP | PW | 28 | 2000 | Green (RoHS & no Sb/Br) | CU NIPDAU | Level-2-260C-1 YEAR |

⁽¹⁾ The marketing status values are defined as follows:

ACTIVE: Product device recommended for new designs.

LIFEBUY: TI has announced that the device will be discontinued, and a lifetime-buy period is in effect.

NRND: Not recommended for new designs. Device is in production to support existing customers, but TI does not recommend using this part in a new design.

PREVIEW: Device has been announced but is not in production. Samples may or may not be available.

OBSOLETE: TI has discontinued the production of the device.

⁽²⁾ Eco Plan - The planned eco-friendly classification: Pb-Free (RoHS), Pb-Free (RoHS Exempt), or Green (RoHS & no Sb/Br) - please check <http://www.ti.com/productcontent> for the latest availability information and additional product content details.

TBD: The Pb-Free/Green conversion plan has not been defined.

Pb-Free (RoHS): TI's terms "Lead-Free" or "Pb-Free" mean semiconductor products that are compatible with the current RoHS requirements for all 6 substances, including the requirement that lead not exceed 0.1% by weight in homogeneous materials. Where designed to be soldered at high temperatures, TI Pb-Free products are suitable for use in specified lead-free processes.

Pb-Free (RoHS Exempt): This component has a RoHS exemption for either 1) lead-based flip-chip solder bumps used between the die and package, or 2) lead-based die adhesive used between the die and leadframe. The component is otherwise considered Pb-Free (RoHS compatible) as defined above.

Green (RoHS & no Sb/Br): TI defines "Green" to mean Pb-Free (RoHS compatible), and free of Bromine (Br) and Antimony (Sb) based flame retardants (Br or Sb do not exceed 0.1% by weight in homogeneous material)

⁽³⁾ MSL, Peak Temp. -- The Moisture Sensitivity Level rating according to the JEDEC industry standard classifications, and peak solder temperature.

Important Information and Disclaimer:The information provided on this page represents TI's knowledge and belief as of the date that it is provided. TI bases its knowledge and belief on information provided by third parties, and makes no representation or warranty as to the accuracy of such information. Efforts are underway to better integrate information from third parties. TI has taken and continues to take reasonable steps to provide representative and accurate information but may not have conducted destructive testing or chemical analysis on incoming materials and chemicals. TI and TI suppliers consider certain information to be proprietary, and thus CAS numbers and other limited information may not be available for release.

In no event shall TI's liability arising out of such information exceed the total purchase price of the TI part(s) at issue in this document sold by TI to Customer on an annual basis.

TAPE AND REEL INFORMATION

QUADRANT ASSIGNMENTS FOR PIN 1 ORIENTATION IN TAPE

*All dimensions are nominal

| Device | Package Type | Package Drawing | Pins | SPQ | Reel Diameter (mm) | Reel Width W1 (mm) | A0 (mm) | B0 (mm) | K0 (mm) | P1 (mm) | W (mm) | Pin1 Quadrant |
|-------------|--------------|-----------------|------|------|--------------------|--------------------|---------|---------|---------|---------|--------|---------------|
| ADS1246IPWR | TSSOP | PW | 16 | 2000 | 330.0 | 12.4 | 7.0 | 5.6 | 1.6 | 8.0 | 12.0 | Q1 |
| ADS1247IPWR | TSSOP | PW | 20 | 2000 | 330.0 | 16.4 | 6.95 | 7.1 | 1.6 | 8.0 | 16.0 | Q1 |
| ADS1248IPWR | TSSOP | PW | 28 | 2000 | 330.0 | 16.4 | 7.1 | 10.4 | 1.6 | 12.0 | 16.0 | Q1 |

TAPE AND REEL BOX DIMENSIONS

*All dimensions are nominal

| Device | Package Type | Package Drawing | Pins | SPQ | Length (mm) | Width (mm) | Height (mm) |
|-------------|--------------|-----------------|------|------|-------------|------------|-------------|
| ADS1246IPWR | TSSOP | PW | 16 | 2000 | 346.0 | 346.0 | 29.0 |
| ADS1247IPWR | TSSOP | PW | 20 | 2000 | 346.0 | 346.0 | 33.0 |
| ADS1248IPWR | TSSOP | PW | 28 | 2000 | 346.0 | 346.0 | 33.0 |

PW (R-PDSO-G**)

PLASTIC SMALL-OUTLINE PACKAGE

14 PINS SHOWN



4040064/F 01/97

- NOTES: A. All linear dimensions are in millimeters.
 B. This drawing is subject to change without notice.
 C. Body dimensions do not include mold flash or protrusion not to exceed 0,15.
 D. Falls within JEDEC MO-153

IMPORTANT NOTICE

Texas Instruments Incorporated and its subsidiaries (TI) reserve the right to make corrections, modifications, enhancements, improvements, and other changes to its products and services at any time and to discontinue any product or service without notice. Customers should obtain the latest relevant information before placing orders and should verify that such information is current and complete. All products are sold subject to TI's terms and conditions of sale supplied at the time of order acknowledgment.

TI warrants performance of its hardware products to the specifications applicable at the time of sale in accordance with TI's standard warranty. Testing and other quality control techniques are used to the extent TI deems necessary to support this warranty. Except where mandated by government requirements, testing of all parameters of each product is not necessarily performed.

TI assumes no liability for applications assistance or customer product design. Customers are responsible for their products and applications using TI components. To minimize the risks associated with customer products and applications, customers should provide adequate design and operating safeguards.

TI does not warrant or represent that any license, either express or implied, is granted under any TI patent right, copyright, mask work right, or other TI intellectual property right relating to any combination, machine, or process in which TI products or services are used. Information published by TI regarding third-party products or services does not constitute a license from TI to use such products or services or a warranty or endorsement thereof. Use of such information may require a license from a third party under the patents or other intellectual property of the third party, or a license from TI under the patents or other intellectual property of TI.

Reproduction of TI information in TI data books or data sheets is permissible only if reproduction is without alteration and is accompanied by all associated warranties, conditions, limitations, and notices. Reproduction of this information with alteration is an unfair and deceptive business practice. TI is not responsible or liable for such altered documentation. Information of third parties may be subject to additional restrictions.

Resale of TI products or services with statements different from or beyond the parameters stated by TI for that product or service voids all express and any implied warranties for the associated TI product or service and is an unfair and deceptive business practice. TI is not responsible or liable for any such statements.

TI products are not authorized for use in safety-critical applications (such as life support) where a failure of the TI product would reasonably be expected to cause severe personal injury or death, unless officers of the parties have executed an agreement specifically governing such use. Buyers represent that they have all necessary expertise in the safety and regulatory ramifications of their applications, and acknowledge and agree that they are solely responsible for all legal, regulatory and safety-related requirements concerning their products and any use of TI products in such safety-critical applications, notwithstanding any applications-related information or support that may be provided by TI. Further, Buyers must fully indemnify TI and its representatives against any damages arising out of the use of TI products in such safety-critical applications.

TI products are neither designed nor intended for use in military/aerospace applications or environments unless the TI products are specifically designated by TI as military-grade or "enhanced plastic." Only products designated by TI as military-grade meet military specifications. Buyers acknowledge and agree that any such use of TI products which TI has not designated as military-grade is solely at the Buyer's risk, and that they are solely responsible for compliance with all legal and regulatory requirements in connection with such use.

TI products are neither designed nor intended for use in automotive applications or environments unless the specific TI products are designated by TI as compliant with ISO/TS 16949 requirements. Buyers acknowledge and agree that, if they use any non-designated products in automotive applications, TI will not be responsible for any failure to meet such requirements.

Following are URLs where you can obtain information on other Texas Instruments products and application solutions:

Products

| | |
|-----------------------------|--|
| Amplifiers | amplifier.ti.com |
| Data Converters | dataconverter.ti.com |
| DLP® Products | www.dlp.com |
| DSP | dsp.ti.com |
| Clocks and Timers | www.ti.com/clocks |
| Interface | interface.ti.com |
| Logic | logic.ti.com |
| Power Mgmt | power.ti.com |
| Microcontrollers | microcontroller.ti.com |
| RFID | www.ti-rfid.com |
| RF/IF and ZigBee® Solutions | www.ti.com/lprf |

Applications

| | |
|--------------------|--|
| Audio | www.ti.com/audio |
| Automotive | www.ti.com/automotive |
| Broadband | www.ti.com/broadband |
| Digital Control | www.ti.com/digitalcontrol |
| Medical | www.ti.com/medical |
| Military | www.ti.com/military |
| Optical Networking | www.ti.com/opticalnetwork |
| Security | www.ti.com/security |
| Telephony | www.ti.com/telephony |
| Video & Imaging | www.ti.com/video |
| Wireless | www.ti.com/wireless |

Mailing Address: Texas Instruments, Post Office Box 655303, Dallas, Texas 75265
Copyright © 2009, Texas Instruments Incorporated