

16-BIT, 2-MSPS, LVDS SERIAL INTERFACE, SAR ANALOG-TO-DIGITAL CONVERTER

FEATURES

- 2-MHz Sample Rate
- 16-Bit Resolution
- SNR 87.5 dB at 10 kHz I/P
- THD –98 dB at 10 kHz I/P
- ± 1 LSB Typ, ± 2.5 LSB INL Max
- $+0.8/-0.5$ LSB Typ, $+1.5/-1$ LSB DNL Max
- Unipolar Differential Input Range: 0 V to 4 V
- Internal Reference
- Internal Reference Buffer
- 200-Mbps LVDS Serial Interface
- Optional 200-MHz Internal Interface Clock
- 16-/8-Bit Data Frame
- Zero Latency at Full Speed
- Power Dissipation: 290 mW at 2 MSPS
- Nap Mode (125 mW Power Dissipation)
- Power Down (5 μ W)
- 48-Pin QFN Package

APPLICATIONS

- Medical Instrumentation
- High-Speed Data Acquisition Systems
- High-Speed Close-Loop Systems
- Communication

DESCRIPTION

The ADS8410 is a 16-bit, 2-MSPS, analog-to-digital (A/D) converter with 4-V internal reference. The device includes a capacitor based SAR A/D converter with inherent sample and hold.

The ADS8410 also includes a 200-Mbps, LVDS, serial interface. This interface is designed to support daisy chaining or cascading of multiple devices. A selectable 16-/8-bit data frame mode enables the use of a single shift register chip (SN65LVDS152) for converting the data to parallel format.

The ADS8410 unipolar single-ended input range supports a differential input swing of 0 V to $+V_{ref}$.

The nap feature provides substantial power saving when used at lower conversion rates.

The ADS8410 is available in a 48-pin QFN package.

High-Speed SAR Converter Family

Type/Speed	500 kHz	~ 600 kHz	750 kHz	1 MHz	1.25 MHz	2 MHz	3 MHz	4 MHz
18-Bit Pseudo-Diff	ADS8383	ADS8381						
		ADS8380 (S)						
18-Bit Pseudo-Bipolar, Fully Diff		ADS8382 (S)						
16-Bit Pseudo-Diff		ADS8370 (S)	ADS8371		ADS8401/05	ADS8411		
						ADS8410 (S-LVDS)		
16-Bit Pseudo-Bipolar, Fully Diff		ADS8372 (S)			ADS8402/06	ADS8412		
						ADS8413 (S-LVDS)		
14-Bit Pseudo-Diff					ADS7890 (S)		ADS7891	
12-Bit Pseudo-Diff								ADS7881



Please be aware that an important notice concerning availability, standard warranty, and use in critical applications of Texas Instruments semiconductor products and disclaimers thereto appears at the end of this data sheet.

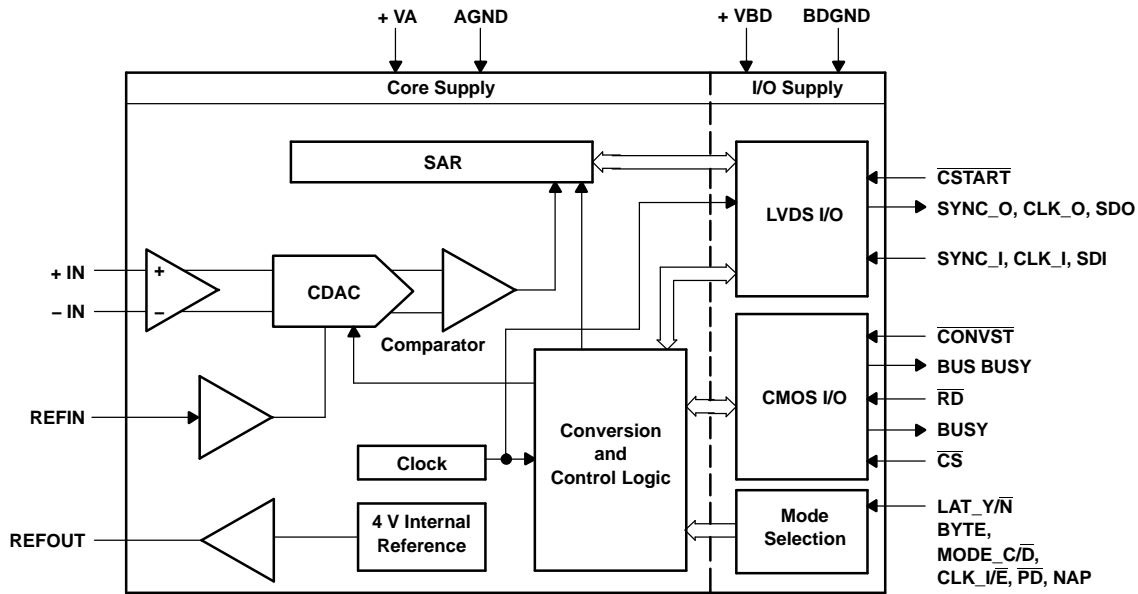

ORDERING INFORMATION⁽¹⁾

MODEL	MAXIMUM INTEGRAL LINEARITY (LSB)	MAXIMUM DIFFERENTIAL LINEARITY (LSB)	NO MISSING CODES AT RESOLUTION (BIT)	PACKAGE TYPE	PACKAGE DESIGNATOR	TEMPERATURE RANGE	ORDERING INFORMATION	TRANSPORT MEDIA QUANTITY
ADS8410IB	±2.5	1.5/-1	16	48 pin QFN	RGZ	-40°C to 85°C	ADS8410IBRGZT	250
							ADS8410IBRGZR	2000
ADS8410I	±4	3/-1	16	48 pin QFN	RGZ	-40°C to 85°C	ADS8410IRGZT	250
							ADS8410IRGZR	2000

(1) For the most current package and ordering information, see the Package Option Addendum at the end of this document, or see the TI website at www.ti.com.

ABSOLUTE MAXIMUM RATINGS

over operating free-air temperature range (unless otherwise noted)⁽¹⁾

		UNIT
+IN to AGND		-0.3 V to +VA + 0.3 V
-IN to AGND		-0.3 V to +0.3 V
+VA to AGND		-0.3 to 7 V
+VBD to BDGND		-0.3 to 7 V
Digital input voltage to GND		-0.3 V to (+VBD + 0.3 V)
Digital output to GND		-0.3 V to (+VBD + 0.3 V)
Operating temperature range		-40°C to 85°C
Storage temperature range		-65°C to 150°C
Junction temperature (T _{Jmax})		150°C
QFN package	Power dissipation	(T _{J Max} - T _A) / θ _{JA}
	θ _{JA} Thermal impedance	86°C/W
Lead temperature, soldering	Vapor phase (60 sec)	215°C
	Infrared (15 sec)	220°C

(1) Stresses beyond those listed under *absolute maximum ratings* may cause permanent damage to the device. These are stress ratings only, and functional operation of the device at these or any other conditions beyond those indicated under *recommended operating conditions* is not implied. Exposure to absolute-maximum-rated conditions for extended periods may affect device reliability.

SPECIFICATIONS

$T_A = -40^{\circ}\text{C}$ to 85°C , $+V_A = 5\text{ V}$, $+V_{BD} = 5\text{ V}$ or 3.3 V , $V_{ref} = 4.096\text{ V}$, $f_{sample} = 2\text{ MHz}$ (unless otherwise noted)

PARAMETER		TEST CONDITIONS	MIN	TYP	MAX	UNIT
ANALOG INPUT						
Full-scale input voltage span ⁽¹⁾		+IN – (–IN)	0		V_{ref}	V
Absolute input voltage range		+IN	–0.2		$V_{ref} + 0.2$	V
		–IN	–0.2		+0.2	
C_i	Input capacitance			25		pF
	Input leakage current			500		pA
SYSTEM PERFORMANCE						
	Resolution			16		Bits
No missing codes		ADS8410IB		16		Bits
		ADS8410I		16		
INL	Integral linearity ⁽²⁾	ADS8410IB	–2.5	± 1	2.5	LSB ⁽³⁾
		ADS8410I	–4.0	± 2.5	4.0	
DNL	Differential linearity	ADS8410IB	–1	0.8/–0.5	1.5	LSB ⁽³⁾
		ADS8410I	–1.0	1.5/–0.8	3	
E_O	Offset error	ADS8410IB	–0.75	± 0.1	0.75	mV
		ADS8410I	–1.5	± 0.75	1.5	
E_G	Gain error ⁽⁴⁾	ADS8410IB	–0.05	± 0.01	0.05	% of FS
		ADS8410I	–0.15	± 0.05	0.15	
CMMR	Common-mode rejection ratio	With common mode input signal = 200 mV _{p-p} at 1 MHz		60		dB
PSRR	Power supply rejection ratio	At FFF0 _H output code		80		dB
SAMPLING DYNAMICS						
Conversion time		+VBD = 5 V		360	391	ns
		+VBD = 3 V			391	
Acquisition time		+VBD = 5 V		100		ns
		+VBD = 3 V		100		
	Maximum throughput rate with or without latency				2.0	MHz
	Aperture delay			20		ns
	Aperture jitter			10		psec
	Step response			50		ns
	Overvoltage recovery			50		ns
DYNAMIC CHARACTERISTICS						
THD	Total harmonic distortion ⁽⁵⁾	V_{IN} 0.5 dB below FS at 10 kHz		–98		dB
		V_{IN} 0.5 dB below FS at 100 kHz		–92.5		
SNR	Signal-to-noise ratio	V_{IN} 0.5 dB below FS at 10 kHz		87.5		dB
		V_{IN} 0.5 dB below FS at 100 kHz		86		
SINAD	Signal-to-noise and distortion	V_{IN} 0.5 dB below FS at 10 kHz		87		dB
		V_{IN} 0.5 dB below FS at 100 kHz		85		
SFDR	Spurious free dynamic range	V_{IN} 0.5 dB below FS at 10 kHz		–101		dB
		V_{IN} 0.5 dB below FS at 100 kHz		–93		
	–3 dB Small signal bandwidth			37.5		MHz
EXTERNAL REFERENCE INPUT						
	Input voltage range, V_{REF}		3.9	4.096	4.2	V
	Resistance ⁽⁶⁾	To internal reference voltage		500		k Ω

- (1) Ideal input span; does not include gain or offset error.
- (2) This is endpoint INL, not best fit.
- (3) Least significant bit
- (4) Measured relative to actual measured reference.
- (5) Calculated on the first nine harmonics of the input frequency.
- (6) Can vary $\pm 20\%$

SPECIFICATIONS (continued)

$T_A = -40^{\circ}\text{C}$ to 85°C , $+VA = 5\text{ V}$, $+VBD = 5\text{ V}$ or 3.3 V , $V_{ref} = 4.096\text{ V}$, $f_{sample} = 2\text{ MHz}$ (unless otherwise noted)

PARAMETER		TEST CONDITIONS	MIN	TYP	MAX	UNIT
INTERNAL REFERENCE OUTPUT						
Start-up time		From 95% (+VA), with 1- μF storage capacitor on REFOUT to AGND			25	ms
Reference voltage range, V_{ref}		At room temperature	4.080	4.096	4.112	V
Source current		Static load			10	μA
Line regulation		+VA = 4.75 V to 5.25 V		0.6		mV
Drift		IOUT = 0 V		36		PPM/ $^{\circ}\text{C}$
POWER SUPPLY REQUIREMENTS						
Power supply voltage	+VBD		2.7	3.3	5.25	V
	+VA		4.75	5	5.25	
Supply current, 2-MHz sample rate		+VA		58	64	mA
Power dissipation, 2-MHz sample rate		+VA = 5 V		290	320	mW
NAP MODE						
Supply current		+VA		25		mA
POWER DOWN						
Supply current		+VA		1	2.5	μA
Powerdown time				10		μs
Powerup time		With 1- μF storage capacitor on REFOUT to AGND		25		ms
Invalid conversions after power up or reset				3		Numbers
TEMPERATURE RANGE						
Operating free air			-40		85	$^{\circ}\text{C}$
LOGIC FAMILY CMOS						
V_{IH}	High-level input voltage	$I_{IH} = 5\ \mu\text{A}$	+VBD -1	+VBD +0.3		V
V_{IL}	Low-level input voltage	$I_{IL} = 5\ \mu\text{A}$	-0.3	0.8		V
V_{OH}	High-level output voltage	$I_{OH} = 2\text{ TTL loads}$	+VBD - 0.6	+VBD		V
V_{OL}	Low-level output voltage	$I_{OL} = 2\text{ TTL loads}$	0	0.4		V
LOGIC FAMILY LVDS(7)						
DRIVER						
$ V_{OD(SS)} $	Steady-state differential output voltage magnitude	$R_L = 100\ \Omega$, See Figure 52 , Figure 53	247	340	454	mV
$\Delta V_{OD(SS)} $	Change in steady-state differential output voltage magnitude between logic states		-50		50	
$V_{OC(SS)}$	Steady-state common-mode output voltage	See Figure 54	1.125	1.2	1.375	V
$\Delta V_{OC(SS)} $	Change in steady-state common-mode output voltage between logic states		-50		50	mV
$V_{OC(pp)}$	Peak to peak change in common-mode output voltage			50	150	
I_{OS}	Short circuit output current	V_{OY} or $V_{OZ} = 0\text{ V}$		3	10	mA
		$V_{OD} = 0\text{ V}$		3	10	
I_{OZ}	High impedance output current	$V_O = 0\text{ V}$ or +VBD	-5		5	μA

(7) All min max values ensured by design.

SPECIFICATIONS (continued)

$T_A = -40^\circ\text{C}$ to 85°C , $+V_A = 5\text{ V}$, $+V_{BD} = 5\text{ V}$ or 3.3 V , $V_{ref} = 4.096\text{ V}$, $f_{sample} = 2\text{ MHz}$ (unless otherwise noted)

PARAMETER		TEST CONDITIONS	MIN	TYP	MAX	UNIT
RECEIVER						
V_{ITH+}	Positive going differential voltage threshold				50	mV
V_{ITH-}	Negative going differential voltage threshold		-50			
V_{IC}	Common mode input voltage		0.2	1.2	2.2	V
C_I	Input capacitance			5		pF

TIMING REQUIREMENTS

$T_A = -40^\circ\text{C}$ to 85°C , $+V_A = 5\text{ V}$, $+V_{BD} = 5\text{ V}$ or 3.3 V (unless otherwise noted)

PARAMETER		MIN	TYP	MAX	UNIT	REF
SAMPLING AND CONVERSION RELATED						
t_{acq}	Acquisition time	100			ns	Figure 1, Figure 2
t_{cnv}	Conversion time			391	ns	Figure 1, Figure 2
t_{w1}	Pulse duration, $\overline{\text{CONVST}}$ high	100			ns	Figure 1
t_{w2}	Pulse duration, $\overline{\text{CONVST}}$ low	40			ns	Figure 1, Figure 2
t_{d1}	Delay time, $\overline{\text{CONVST}}$ rising edge to sample start			5	ns	Figure 1
t_{d2}	Delay time, $\overline{\text{CONVST}}$ falling edge to conversion start			5	ns	Figure 1, Figure 2
t_{d3}	Delay time, $\overline{\text{CONVST}}$ falling edge to busy high	+VBD = 3.3 V		14	ns	Figure 1, Figure 2
		+VBD = 5 V		13		
t_{d4}	Delay time, conversion end to busy low	+VBD = 3.3 V		8	ns	Figure 1, Figure 2
		+VBD = 5 V		7		
t_{w3}	Pulse duration, $\overline{\text{CSTART}}$ high	100			ns	Figure 1, Table 2
t_{w4}	Pulse duration, $\overline{\text{CSTART}}$ low	45			ns	Figure 1, Figure 2, Table 2
t_{d5}	Delay time, $\overline{\text{CSTART}}$ rising edge to sample start			7.5	ns	Figure 1, Table 2
t_{d6}	Delay time, $\overline{\text{CSTART}}$ falling edge to conversion start			7.5	ns	Figure 1, Figure 2, Table 2
t_{d7}	Delay time, $\overline{\text{CSTART}}$ falling edge to busy high	+VBD = 3.3 V		16.5	ns	Figure 1, Figure 2, Table 2
		+VBD = 5 V		15.5		
I/O RELATED						
t_{d8}	Delay time, $\overline{\text{RD}}$ falling edge while $\overline{\text{CS}}$ low to BUS_BUSY high			16	ns	Figure 5
t_{d9}	Delay time, $\overline{\text{RD}}$ falling edge while $\overline{\text{CS}}$ low to SYNC_O and SDO out of 3-state condition (for device with LAT_Y/N pulled low)	+VBD = 3.3 V		29	ns	Figure 5
		+VBD = 5 V		28		
t_{d10}	Delay time, pre_conversion end (point A) to SYNC_O and SDO out of 3-state condition			22	ns	Figure 6
t_{d11}	Delay time, pre_conversion end (point A) to BUS_BUSY high	+VBD = 3.3 V		8	ns	Figure 6
		+VBD = 5 V		7		
t_{d12}	Delay time, conversion phase end to SYNC_O high	6		$9 + t_{CLK}$	ns	Figure 6
t_{d13}	Delay time, $\overline{\text{RD}}$ falling edge while $\overline{\text{CS}}$ low to SYNC_O high	+VBD = 3.3 V	$5.5 + 4 * t_{CLK}$	$8.5 + 5 * t_{CLK}$	ns	Figure 5
		+VBD = 5 V	$5 + 4 * t_{CLK}$	$8 + 5 * t_{CLK}$		
t_{w5}	Pulse duration, $\overline{\text{RD}}$ low for device in no latency mode	5			ns	Figure 11
t_{d14}	Delay time, CLK_O rising edge to data valid	+VBD = 3.3 V		1.4	ns	Figure 5, Figure 6
		+VBD = 5 V		1.3		
t_{d15}	Delay time, BUS_BUSY low to SYNC_O high in daisy chain mode indicating receiving device to output data	+VBD = 3.3 V	$4 * t_{CLK} - 6.5$	$4 * t_{CLK} - 3$	ns	Figure 7, Figure 12
		+VBD = 5 V	$4 * t_{CLK} - 6$	$4 * t_{CLK} - 2.5$		

TIMING REQUIREMENTS (continued)

T_A = –40°C to 85°C, +VA = 5 V, +VBD = 5 V or 3.3 V (unless otherwise noted)

PARAMETER		MIN	TYP	MAX	UNIT	REF
t _{d16}	Delay time, CLK_O to SDO and SYNC_O 3-state			4	ns	Figure 7, Figure 8, Figure 12, Figure 15
t _{pd1}	Propagation delay time, SYNC_I to SYNC_O in daisy chain mode		11 + 0.5*t _{CLK}		ns	Figure 12
t _{d17}	Delay time, SYNC_O and SDO 3-state to BUS_BUSY low in cascade mode	0		2	ns	Figure 8
t _{d18}	Delay time, \overline{RD} rising edge to BUS_BUSY high for device with LAT_Y/ \overline{N} = 1	+VBD = 3.3 V		8	ns	Figure 11, Figure 14
		+VBD = 5 V		7		
t _{d19}	Delay time, point A indicating clear for bus 3-state release to BUSY falling edge	+VBD = 3.3 V		40.5	ns	Figure 6
		+VBD = 5 V		40		
t _r	Rise time, differential LVDS output signal			950	ps	Figure 53
t _f	Fall time, differential LVDS output signal			950	ps	Figure 53
	CLK frequency (serial data rate)	190		210	MHz	
t _{d20}	Delay time, from \overline{PD} falling edge to SDO 3-state			10	ns	Figure 22, Figure 23
t _{d21}	Delay time, from \overline{PD} falling edge to device powerdown			10	μs	Figure 22, Figure 23
t _{d22}	Delay time, from \overline{PD} rising edge to device powerup			25	ms	Figure 22, Figure 23
t _{s1}	Settling time, internal reference after first three conversions			4	ms	Figure 22
t _{d23}	Delay time, \overline{CONVST} falling edge to start of restricted zone for start of data read cycle			335	ns	Figure 9
t _{d24}	Delay time, \overline{CONVST} falling edge to end of restricted zone for start of data read cycle			406	ns	Figure 9

DEVICE INFORMATION

RGZ PACKAGE (TOPVIEW)

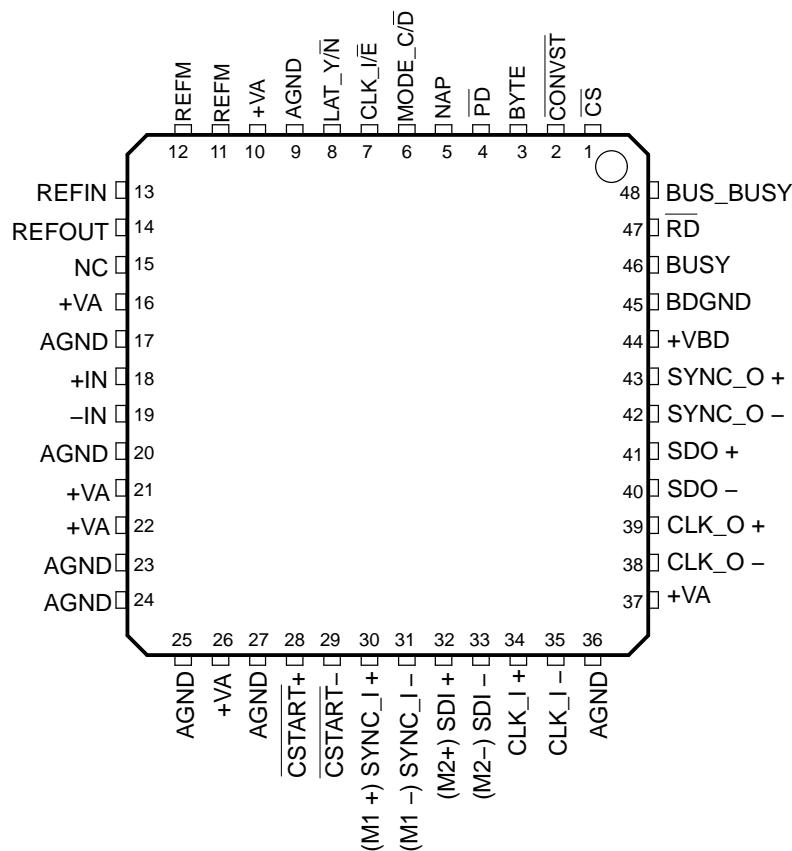

NC – No internal connection

TERMINAL FUNCTIONS

TERMINAL		I/O	DESCRIPTION
NO.	NAME		
ANALOG PINS			
11, 12	REFM	I	Reference ground. Connect to analog ground plane.
13	REFIN	I	Reference (positive) input. Decouple with REFM pin using 0.1- μ F bypass capacitor and 1- μ F storage capacitor.
14	REFOUT	O	Internal reference output. Short to REFIN pin when the internal reference is used. Do not connect to the REFIN pin when an external reference is used. Always decouple with AGND using a 0.1- μ F bypass capacitor.
18	+IN	I	Noninverting analog input channel
19	-IN	I	Inverting analog input channel (supports ± 0.2 V i/p range)
LVDS I/O PINS⁽¹⁾			
28, 29	<u>CSTART+</u> <u>CSTART-</u>	I	Device sample and convert control input. Device enters sample phase with the rising edge of CSTART and the conversion phase starts with the falling edge of CSTART (provided other conditions are satisfied). Set CSTART = 0 when the CONVST input is used.

(1) All LVDS inputs and outputs are differential with signal+ and signal- lines. Whenever only the 'signal' is mentioned it refers to the signal+ line and the signal- line is the compliment. For example CLK_O refers to CLK_O+ and CLK_O- is the compliment.

DEVICE INFORMATION (continued)

TERMINAL FUNCTIONS (continued)

TERMINAL		I/O	DESCRIPTION
NO.	NAME		
30, 31	SYNC_I + SYNC_I-	I Daisy Chain	Connect to previous device SYNC_O with same polarity, while the device is selected to operate in daisy chain mode.
	M1+ M1-	I Cascade	Mode 1 (valid in cascade mode only). CLK_O is available while M1=1 (LVDS) or M1+ is pulled up to +VBD and M1- is grounded (AGND). CLK_O o/p goes to 3-state when M1 = 0 (LVDS) or M1+ is grounded (AGND) and M1- is pulled up to +VBD. Do not allow these pins to float.
32, 33	SDI+ SDI-	I Daisy Chain	Serial data input. Connect to previous device SDO with same polarity, while the device is selected to operate in daisy chain mode.
	M2+ M2-	I Cascade	Mode 2 (valid in cascade mode only). Doubles LVDS o/p current while M2 = 1 (LVDS) or M2+ is pulled up to +VBD and M2- is grounded (AGND). LVDS o/p current is normal (3.4 mA typ) when M2 = 0 (LVDS) or M2+ is grounded (AGND) and M2 - is pulled up to +VBD. Do not allow these pins to float.
34, 35	CLK_I+ CLK_I-	I	Serial external clock input. Set CLK_I/E (pin 7) = 0 to select an external clock source.
38, 39	CLK_O- CLK_O+	O	Serial clock out. Data is latched out on the rising edge of CLK_O and can be captured on the next falling edge.
40, 41	SDO- SDO+	O	Serial data out. Data is latched out on the rising edge of CLK_O with MSB first format.
42, 43	SYNC_O - SYNC_O +	O	Synchronizes the data frame. ⁽²⁾
CMOS I/O PINS			
1	\overline{CS}	I	Chip select, active low signal. All of the LVDS o/p except CLK_O are 3-state if this pin is high.
2	\overline{CONVST}	I	CMOS equivalent of \overline{CSTART} input. So functionality is the same as the \overline{CSTART} input. Set \overline{CONVST} = 0 when the \overline{CSTART} input is used.
3	BYTE	I	Controls the data frame ⁽²⁾ duration. The frame duration is 16 CLKs if BYTE = 0 or 8 CLKs if BYTE = 1.
4	\overline{PD}	I	Active low input, acts as device power down.
5	NAP	I	Selects nap mode while high. Device enters the nap state at conversion end and remains so until the next acquisition phase begins.
6	MODE_C/D	I	Selects cascade (MODE_C/D = 1) or daisy chain mode (MODE_C/D = 0).
7	CLK_I/E	I	Selects the source of the I/O clock. CLK_I/E = 1 selects internally generated clock with 200-MHz typ frequency. CLK_I/E = 0 selects CLK_I as the I/O clock.
8	LAT_Y/N	I	Controls the data read with latency (LAT_Y/N = 1) or without latency ((LAT_Y/N = 0). It is essential to set LAT_Y/N = 0 for the first device in daisy chain or cascade.
46	BUSY	O	Active high signal, indicates a conversion is in progress.
47	\overline{RD}	I	Data read request to the device, also acts as a handshake signal for daisy chain and cascade operation.
48	BUS_BUSY	O	Status output. Indicates that the bus is being used by the device. Connect to \overline{RD} of the next device for daisy chain or cascade operation.
POWER SUPPLY PINS			
10, 16, 21, 22, 26, 37	+VA	-	Analog power supply and LVDS input buffer power supply.
9, 17, 20, 23, 24, 25, 27, 36	AGND	-	Analog ground pins. Short to the analog ground plane below the device.
44	+VBD	-	Digital power supply for all CMOS digital inputs and CMOS LVDS outputs.
45	BDGND	-	Digital ground for all digital inputs and outputs. Short to the analog ground plane below the device.

(2) The duration from the first rising edge of SYNC_O to the second rising edge of SYNC_O is one data frame. The data frame duration is 16 CLKs if BYTE = 0 or 8 CLKs if BYTE = 1.

DEVICE INFORMATION (continued)

TERMINAL FUNCTIONS (continued)

TERMINAL		I/O	DESCRIPTION
NO.	NAME		
NOT CONNECTED PINS			
15	NC	–	No connection pins

Table 1. Device Configuration for Various Modes of Operation

OPERATION MODE	DEVICE PINS AND RECOMMENDED LOGIC LEVELS							COMMENTS	REFERENCE FIGURES	
	MODE_C/D	CLK_I/E	LAT_Y/N	M1+	M1–	M2+	M2–		FOR SAMPLING AND CONVERSION	FOR DATA READ
Single device	1	1 or 0	0	+VBD or M1 = 1 LVDS	AGND	AGND or M2 = 0 LVDS	+VBD	Recommended configuration	1 or 2	See Figures 3,4 and 5,6,8 for more details
	0	1 or 0	0	See comments	See comments	See comments	See comments			
Multiple devices in daisy chain	1st Device	0	1 or 0	0	See comments	See comments	See comments	Set SYNC_I and SDI to logic 0 or + terminal to AGND and –ve terminal to +VBD	1 or 2	See Figures 3,4,11 and 6,12 for more details
	2nd To last device	0	0	1	See comments	See comments	Maximum 4 devices supported at 2 MSPS with 200-MHz CLK			
Multiple devices in cascade	1st Device	1	0	0	+VBD or M1 = 1 LVDS	AGND	AGND or M2 = 0 LVDS ⁽¹⁾	Maximum 3 devices supported at 2 MSPS	1 or 2	See Figures 3,4,14 and 6,15 for more details
	2nd To last device	1	0	1	+VBD or M1 = 0 LVDS	AGND	+VBD or M2 = 0 LVDS ⁽¹⁾			

(1) Specified polarity is suitable for a 100-Ω differential load across the LVDS outputs. However, polarity can be reversed to double the output current in order to support two 100-Ω loads on both ends of the transmission lines, resulting in 50-Ω net load.

DETAILED DESCRIPTION

SAMPLE AND CONVERT

The sampling and conversion process is controlled by the $\overline{\text{CSTART}}$ (LVDS) or $\overline{\text{CONVST}}$ (CMOS) signal. Both signals are functionally identical. The following diagrams show control with $\overline{\text{CONVST}}$. The rising edge of $\overline{\text{CONVST}}$ (or $\overline{\text{CSTART}}$) starts the sample phase, if the conversion has completed and the device is in the wait state. Figure 2 shows the case when the device is in the conversion phase at the rising edge of $\overline{\text{CONVST}}$. In this case, the sample phase starts immediately at the end of the conversion phase and there is no wait state.

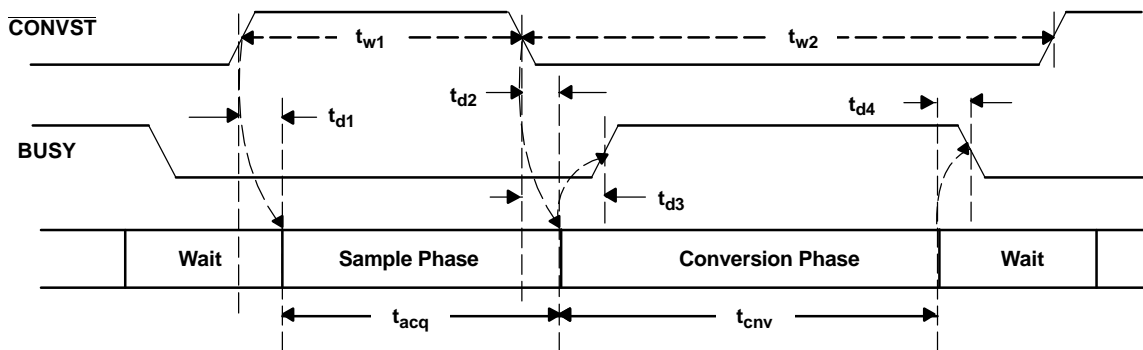

Figure 1. Sample and Convert With Wait (Less Than 2 MSPS Throughput)

DETAILED DESCRIPTION (continued)

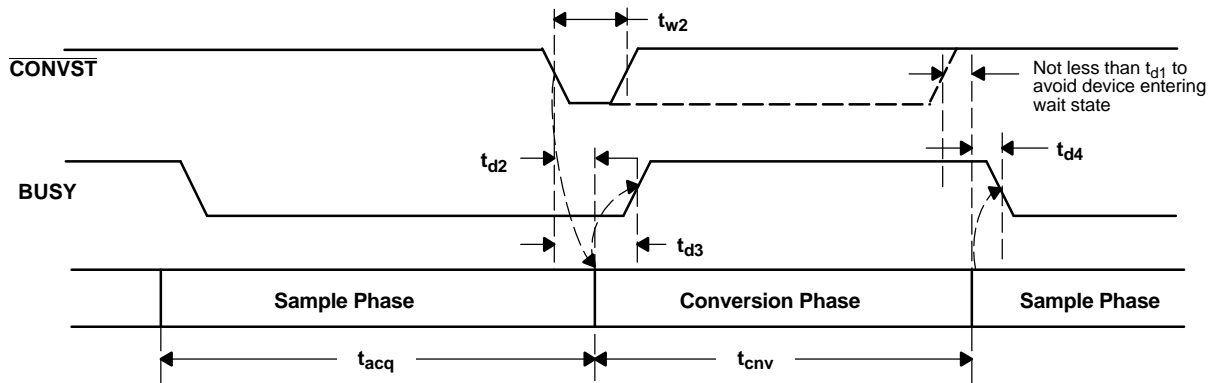

Figure 2. Sample and Convert With No Wait or Back to Back (2 MSPS Throughput)

The device ends the sample phase and enters the conversion phase on the falling edge of $\overline{\text{CONVST}}$ ($\overline{\text{CSTART}}$). A high level on the BUSY output indicates an ongoing conversion. The device conversion time is fixed. The falling edge of $\overline{\text{CONVST}}$ ($\overline{\text{CSTART}}$) during the conversion phase aborts the ongoing conversion. A data read after a conversion abort fetches invalid data. Valid data is only available after a sample phase and a conversion phase has completed. The timing diagram for control with $\overline{\text{CSTART}}$ is similar to Figure 1 and Figure 2. Table 2 shows the equivalent timing for control with $\overline{\text{CONVST}}$ and $\overline{\text{CSTART}}$.

Table 2. $\overline{\text{CONVST}}$ and $\overline{\text{CSTART}}$ Timing Control

TIMING CONTROL WITH $\overline{\text{CONVST}}$	TIMING CONTROL WITH $\overline{\text{CSTART}}$
t_{w1}	t_{w3}
t_{w2}	t_{w4}
t_{d1}	t_{d5}
t_{d2}	t_{d6}
t_{d3}	t_{d7}

DATA READ OPERATION

The ADS8410 supports a 200-MHz serial LVDS interface for data read operation. The three signal LVDS interface (SDO, CLK_O, and SYNC_O) is well suited for high-speed data transfers. An application with a single device or multiple devices can be implemented with a daisy chain or cascade configuration. The following sections discuss data read timing when a single device is used.

DATA READ FOR A SINGLE DEVICE (See Table 1 for Device Configuration)

For a single device, there are two possible read cycle starts: a data read cycle start during a wait or sample phase or a data read cycle start at the end of a conversion phase. Read cycle end conditions can change depending on MODE C/D selection. Figure 3 explains the data read cycle. The details of a read frame start with the two previous listed conditions and a read cycle end with MODE C/D selection are explained in Figure 5 and Figure 6 and Figure 7 and Figure 8, respectively.

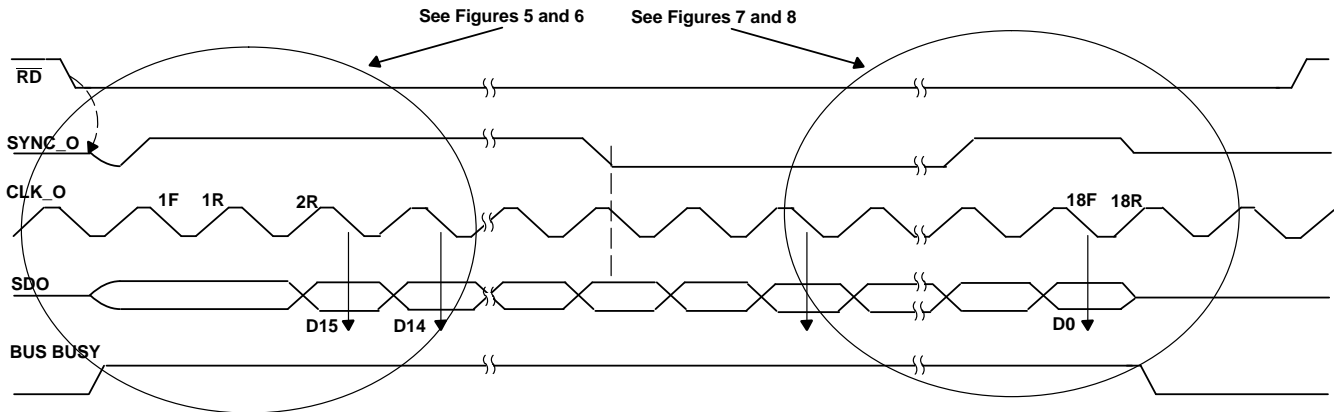

Figure 3. Data Read With \overline{CS} Low and BYTE = 0

As shown in Figure 3, a new data read cycle is initiated with the falling edge of \overline{RD} , if \overline{CS} is low and the device is in a wait or sample phase. The device releases the LVDS o/p (SYNC_O, SDO) from 3-state and sets BUS_BUSY high at the start of the read cycle. The SYNC_O cycle is 16 clocks wide (rising edge to rising edge) if BYTE i/p is held low and can be used to synchronize a data frame. The clock count begins with the first CLK_O falling edge after a SYNC_O rising edge. The MSB is latched out on the second rising edge (2R) and each subsequent data bit is latched out on the rising edge of the clock. The receiver can shift data bits on the falling edges of the clock. The next rising edge of SYNC_O coincides with the 16th rising edge of the clock. D0 is latched out on the 17th rising edge of the clock. The receiver can latch the de-serialized 16-bit word on the 18th rising edge (18R, or the second rising edge after a SYNC_O rising edge).

\overline{CS} high during a data read 3-states SYNC_O and SDO. These signals remain in 3-state until the start of the next data read cycle.

DATA READ IN BYTE MODE

Byte mode is selected by setting BYTE = 1; this mode is allowed for any condition listed in Table 1. Figure 4 shows a data read operation in byte mode.

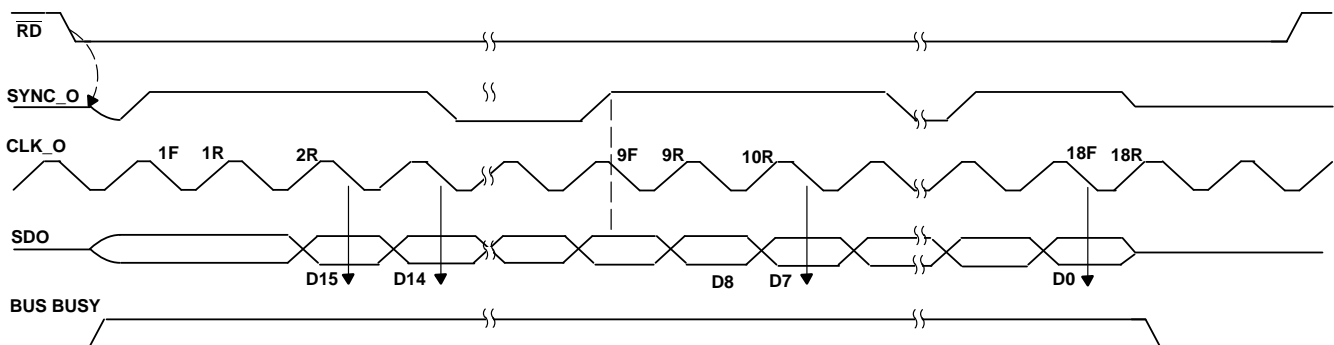

Figure 4. Data Read Timing Diagram with \overline{CS} Low and BYTE = 1

Similar to Figure 3, a new data read cycle is initiated with the falling edge of \overline{RD} , if \overline{CS} is low and the device is in a wait or sample phase. The device releases the LVDS o/p (SYNC_O, SDO) from 3-state and sets BUS_BUSY high at the start of the read cycle. The SYNC_O cycle is 8 clocks wide (rising edge to rising edge) if BYTE i/p is held high and can be used to synchronize a data frame. The clock count begins with the first falling edge of CLK_O after the rising edge of SYNC_O. The MSB is latched out on the second rising edge (2R) and each subsequent data bit is latched out on the rising edge of the clock. The receiver can shift data bits on the falling edges of clock. The next rising edge of SYNC_O coincides with the 8th rising edge of the clock. D8 is latched out on the 9th rising edge of the clock. The receiver can latch the de-serialized higher byte on the 10th rising edge (10R, or second rising edge after a SYNC_O rising edge). The de-serialized lower byte can be latched on the 18th rising edge (18R).

\overline{CS} high during a data read 3-states SYNC_O and SDO. These signals remain in 3-state until the start of the next data read cycle.

DATA READ CYCLE START DURING WAIT OR SAMPLE PHASE

As shown in Figure 5, the falling edge of \overline{RD} , with \overline{CS} low and the device is in a wait or sample phase, triggers the start of a read cycle. The cycle starts when BUS_BUSY goes high and SYNC_O and SDO are released from 3-state. SYNC_O is low at the start and rises to a high level t_{d13} ns after the falling edge of \overline{RD} . As shown in Figure 5, the MSB is shifted on the 2nd rising edge of the clock (2R). Other details about the data read cycle are discussed in the previous section (see Figure 3).

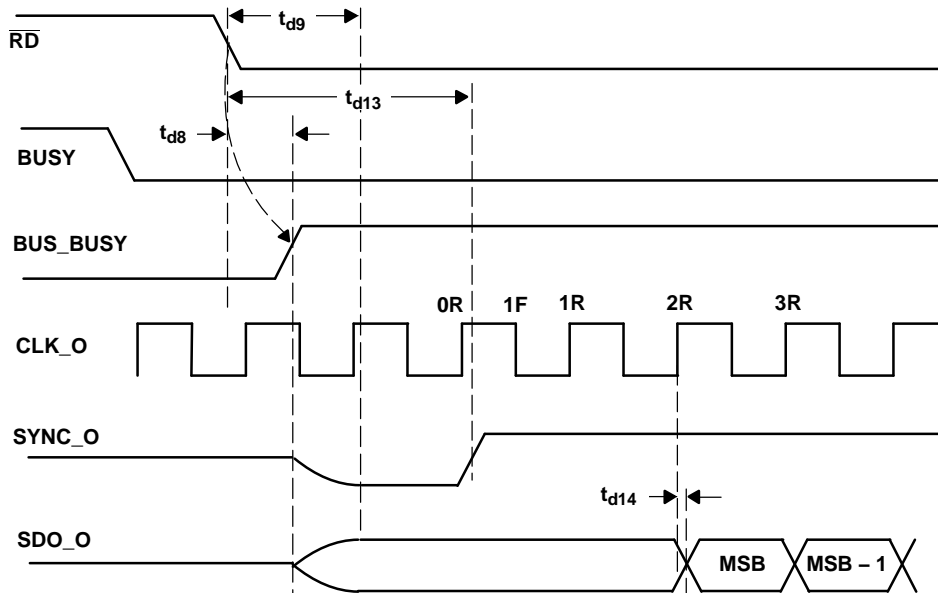

Figure 5. Start of Data Read Cycle with \overline{RD} with \overline{CS} Low and Device in Wait or Sample Phase

DATA READ CYCLE START AT END OF CONVERSION PHASE (Read Without Latency, Back-to-Back)

This mode is optimized for a data read immediately after the end of a conversion phase and ensures the data read is complete before the sample end while running at 2 MSPS. Point A in Figure 6 indicates a 'pre_conversion_end'; it occurs t_{d19} ns before the falling edge of BUSY or $[(t_{d2} + t_{cnv} + t_{d4}) - t_{d19}]$ ns after the falling edge of \overline{CONVST} . A read cycle is initiated at point A if \overline{RD} is issued before point A while \overline{CS} is low. Alternately, \overline{RD} and \overline{CS} can be held low. At the start of the read cycle, BUS_BUSY rises to a high level and the LVDS outputs are released from 3-state. The rising edge of SYNC_O occurs t_{d12} ns after the conversion end. As shown in Figure 6, the MSB is shifted on the 2nd rising edge of the clock (2R). Other details about the data read cycle are discussed in the previous section (see Figure 3).

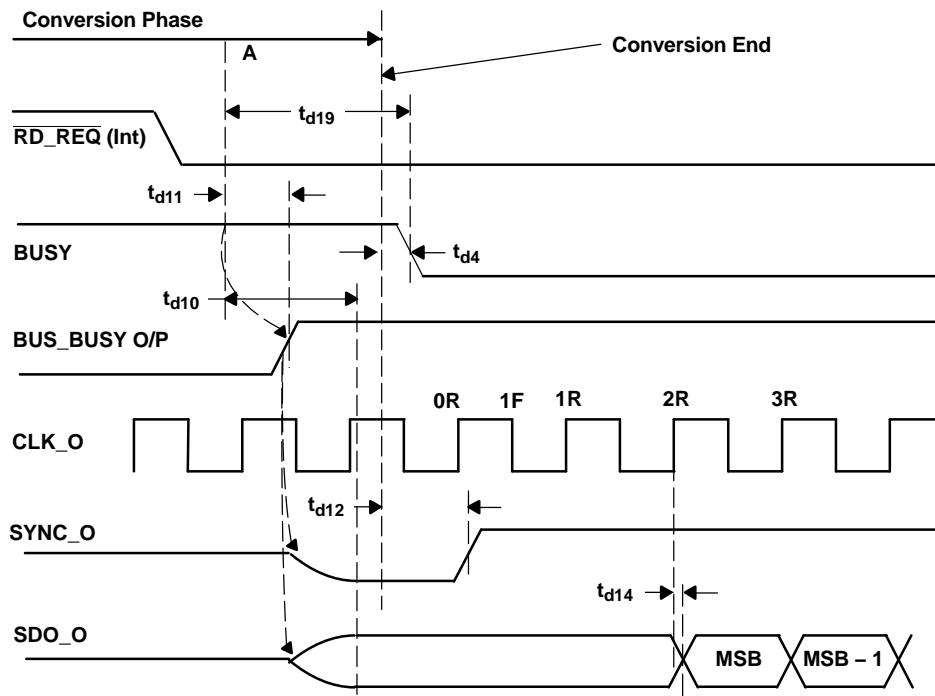

Figure 6. Start of Data Read Cycle with End of Conversion

DATA READ CYCLE END (With $\text{MODE } \overline{\text{C/D}} = 0$)

A data read cycle ends after all 16 bits have been serially latched out. Figure 7 shows the timing of the falling edge of BUS_BUSY and the rising edge of SYNC_O with respect to SDO. SYNC_O rises on the 16th rising edge of CLK_O. As shown in Figure 5 and Figure 6, the MSB is shifted out on the 2nd rising edge of CLK_O. Therefore, the LSB-1 is shifted out on the 16th rising edge of CLK_O.

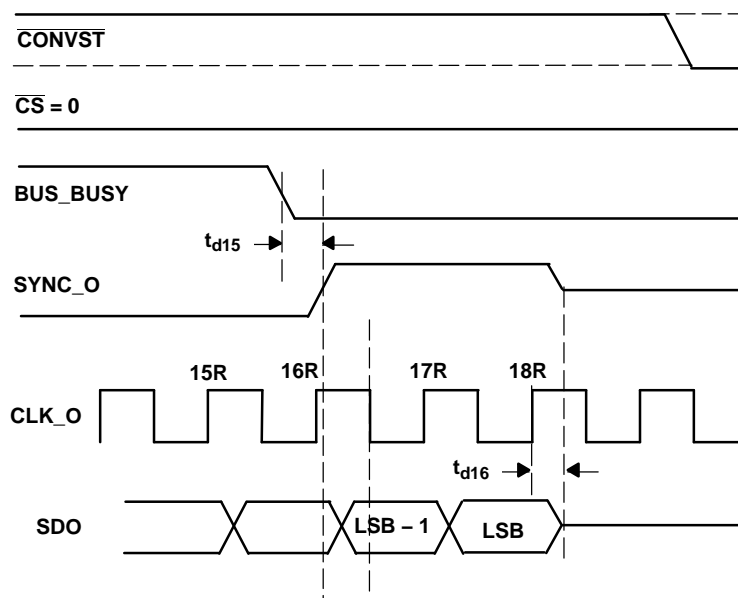

Figure 7. Data Read Cycle End with $\text{MODE } \overline{\text{C/D}} = 0$

The next two rising edges of CLK_O are shown as 17R and 18R in Figure 7. On 17R the LSB is latched out, and on 18R SDO and SYNC_O go to 3-state. Note that BUS_BUSY falls t_{d15} ns before the rising edge of SYNC_O when MODE C/D = 0. Care must be taken not to allow LVDS bus usage by any other device until the end of the read cycle or $(t_{d15} + 2/f_{clk} + t_{d16})$ ns after the falling edge of BUS_BUSY.

DATA READ CYCLE END (With MODE C/D = 1)

A data read cycle ends after all 16 bits have been serially latched out. Figure 8 shows the timing of the falling edge of BUS_BUSY and the rising edge of SYNC_O with respect to SDO. SYNC_O rises on the 16th rising edge of CLK_O. As shown in Figure 5 and Figure 6, the MSB is shifted out on the 2nd rising edge of CLK_O. Therefore, the LSB-1 is shifted out on the 16th rising edge of CLK_O.

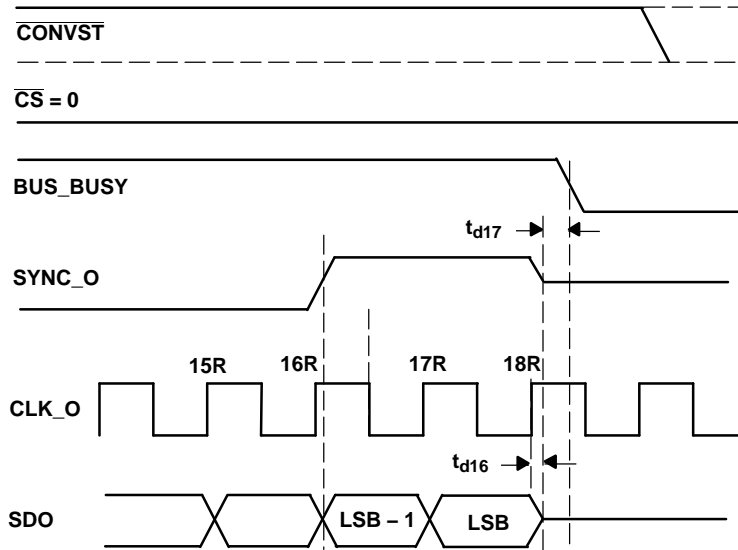

Figure 8. Data Read Cycle End with MODE C/D = 1

The next two rising edges of CLK_O are shown as 17R and 18R in Figure 8. On 17R the LSB is latched out and on 18R SDO and SYNC_O go to 3-state. In cascade mode (with MODE C/D = 1), unlike daisy chain mode, the falling edge of BUS_BUSY occurs after the LVDS outputs are 3-stated. One can use the falling edge of BUS_BUSY to allow LVDS bus usage by any other device.

RESTRICTIONS ON READ CYCLE START

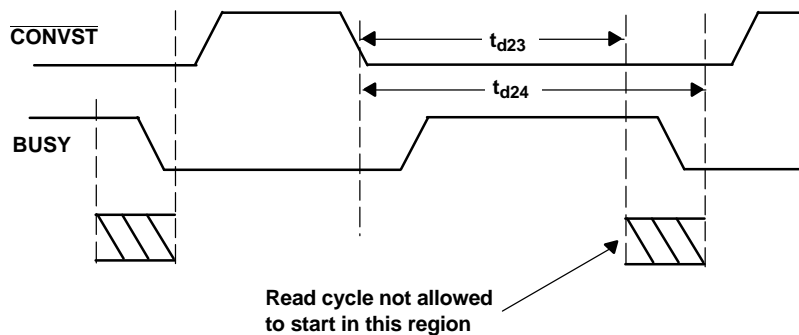

Figure 9. Read Cycle Restriction Region

The start of a data read cycle is not allowed in the region bound by t_{d23} and t_{d24} . Previous conversion results are available for a data read cycle start before this region, and current conversion results are available for a read cycle start after this region.

MULTIPLE DEVICES IN DAISY CHAIN OR CASCADE

Multiple devices can be connected in either a daisy chain or cascade configuration. The following sections describe detailed timing diagrams and electrical connections. The ADS8410 provides all of the handshake signals required for both of these modes. $\overline{\text{CONVST}}$ or $\overline{\text{CSTART}}$ is the only external signal needed for operation.

DAISY CHAIN

Figure 10 shows the first two devices in daisy chain. The signals shown by double lines are LVDS and the others are CMOS. Daisy chain mode is selected by setting $\text{MODE_C}/\overline{\text{D}} = 0$. The first device in the chain is identified by selecting $\text{LAT_Y}/\overline{\text{N}} = 0$.

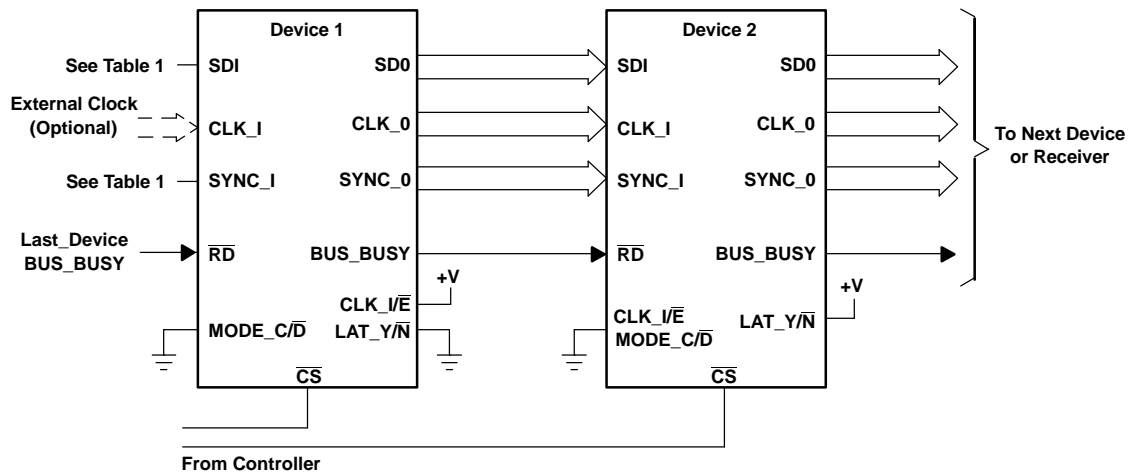

Figure 10. Connecting Multiple Devices in Daisy Chain

For all other devices in the chain $\text{LAT_Y}/\overline{\text{N}} = 1$. See Table 1 for more details on device configurations. SDO , CLK_O , and SYNC_O of device n are connected to SDI , CLK_I , and SYNC_I of device $n+1$. SDO , CLK_O , and SYNC_O of the last device in the chain go to the receiver. BUS_BUSY of device n is connected to $\overline{\text{R_D}}$ of device $n+1$ and so on. Finally, BUS_BUSY of the last device in the chain is connected to $\overline{\text{R_D}}$ of device 1. This ensures the necessary handshake to seamlessly propagate the data of all devices through the chain (it is also allowed to tie $\overline{\text{R_D}} = 0$ for device 1).

TIMING DIAGRAMS FOR DAISY CHAIN OPERATION

The conversion speed for n devices in the chain must be selected such that:

$$1/\text{conversion speed} > \text{read startup delay} + n * (\text{data frame duration}) + t_{d16}$$

$$\text{Read startup delay} = 10 \text{ ns} + (t_{d19} - t_{d4}) + t_{d12} + 2/f_{\text{CLK}}$$

$$\text{Data frame duration} = 16/f_{\text{CLK}}$$

Note that it is not necessary for all devices in the chain to sample the data simultaneously. But all of the devices must operate with the same exact conversion speed.

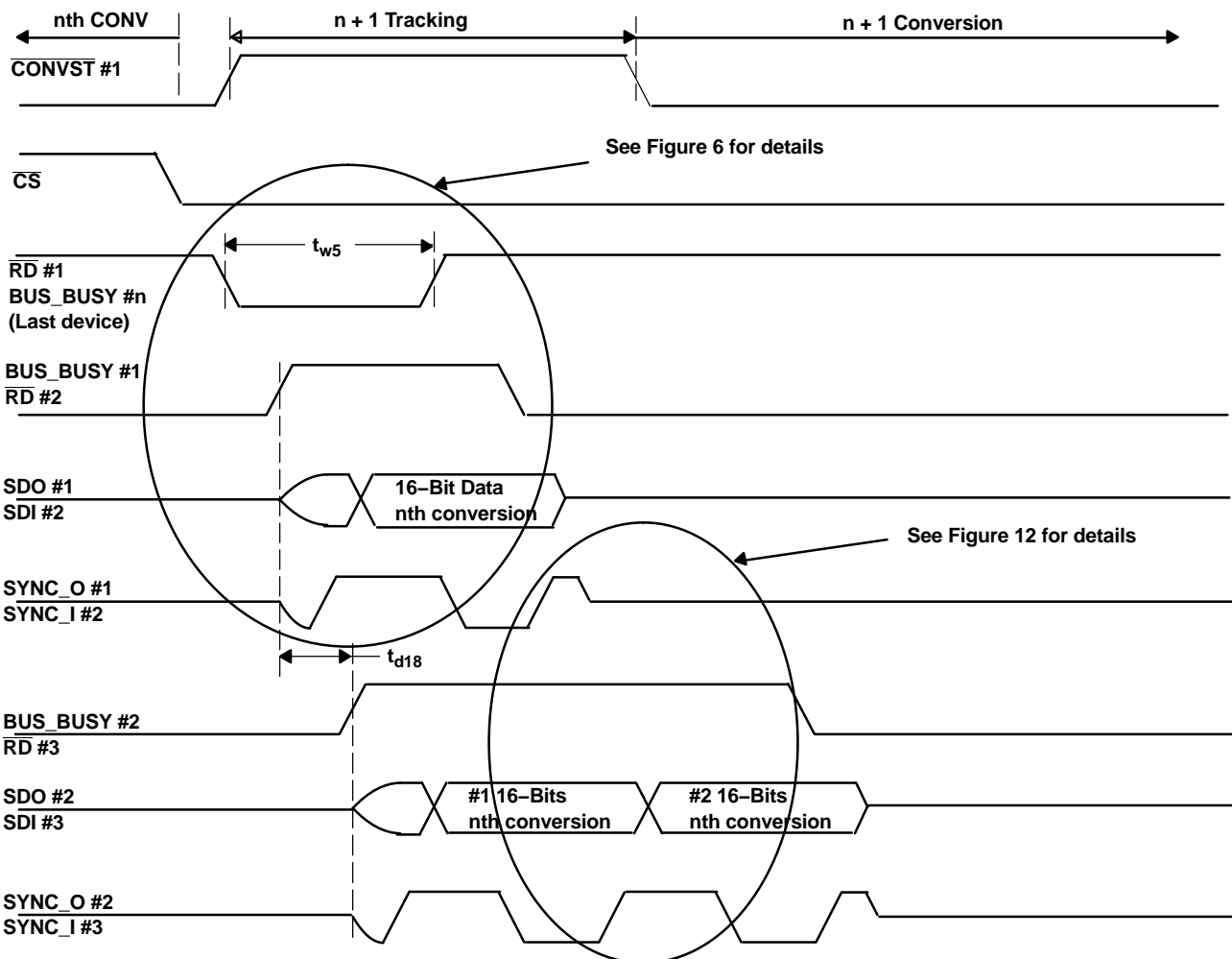

Figure 11. Data Read Operation for Devices in Daisy Chain

DATA READ OPERATION

On power up, BUS_BUSY of all of the devices is low. The devices receive $\overline{\text{CONVST}}$ or $\overline{\text{CSTART}}$ to sample and start the conversion. The first device in the chain starts the data read cycle at the end of its conversion. BUS_BUSY of device 1 (connected to $\overline{\text{RD}}$ of device 2) goes high on the read cycle start. Device 2 BUS_BUSY goes high on the rising edge of $\overline{\text{RD}}$. This propagates until the last device in the chain. Device 2 receives CLK_I, SDI, and SYNC_I from device 1 and it passes all of these signals to the next device. Device 2 (and every subsequent device in the chain) passes the received signals to its output until it sees the falling edge of $\overline{\text{RD}}$ (same as BUS_BUSY of the previous device). In daisy chain mode, BUS_BUSY for any device falls when it has passed all of the previous device data followed by its own data. The falling edge of BUS_BUSY occurs before the rising edge of SYNC_O. This indicates to the receiving device that the previous data chain is over and it is its own turn to output the data. The device outputs the data from the last completed conversion. BUS_BUSY of the last device in the chain is fed back to $\overline{\text{RD}}$ of the first device as shown in Figure 10 (or device 1 $\overline{\text{RD}}$ tied to 0). This makes sure that $\overline{\text{RD}}$ of device 1 is low before its conversion is over. The chain continues with only one external signal ($\overline{\text{CONVST}}$ or $\overline{\text{CSTART}}$) when $\overline{\text{CS}}$ is held low. Every device LVDS output goes to 3-state once all data transfer through the device has been completed.

$\overline{\text{CS}}$ going high during the data read cycle of any device 3-states its SYNC_O and SDO. This halts the propagation of data through the chain. To reset this condition it is necessary to assert $\overline{\text{CS}}$ high for all devices. The new read sequence starts only after $\overline{\text{CS}}$ for all devices is low before point A shown in Figure 6. The high pulse on $\overline{\text{CS}}$ must be at least 20 ns wide. It is better to connect $\overline{\text{CS}}$ of all of the devices together to avoid undesired halting of the daisy chain.

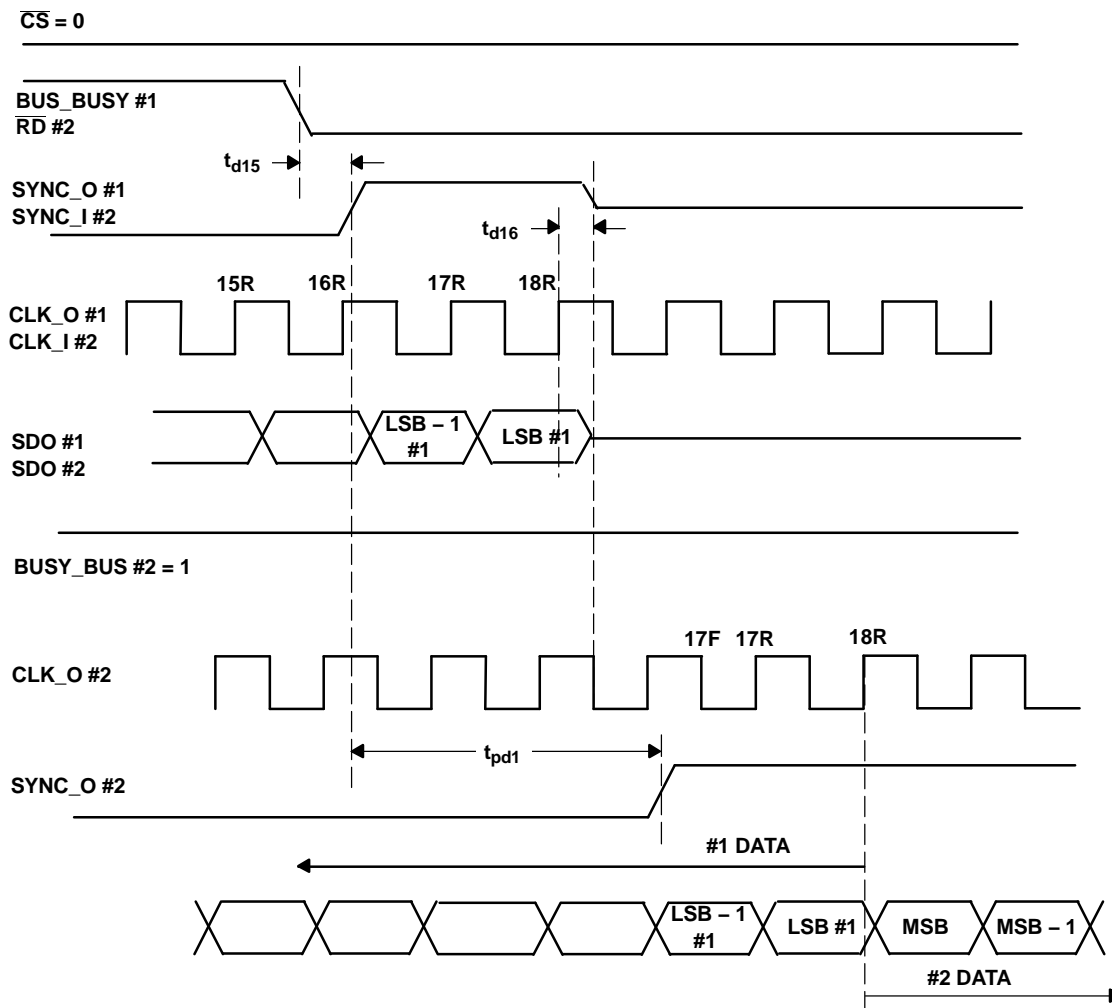

Figure 12. Data Propagation from Device n to Device $n+1$ in Daisy Chain Mode

As shown in [Figure 12](#) there is a propagation delay of t_{pd1} from SYNC_I to SYNC_O or SDI to SDO. Note that the data frames of all devices in the chain appear seamless at the last device output. The rising edge of SYNC occurs at an interval of 16 clocks (or 8 clocks in BYTE mode); this can be used as a data frame sync. The deserializer at the output of the last device can shift the data on every falling edge of the clock and it can latch the parallel 16-bit word on the second rising edge of CLK_O (shown as 18R) after every rising edge of SYNC_O.

CASCADE

[Figure 13](#) shows the cascade connection. The signals shown by double lines are LVDS and the others are CMOS. Cascade mode is selected by setting $MODE_{C/D} = 1$. Similar to daisy chain, the first device in the chain is identified by selecting $LAT_{Y/\bar{N}} = 0$. For all other devices in the chain $LAT_{Y/\bar{N}} = 1$. See [Table 1](#) for more details on device configuration. SDO, CLK_O, and SYNC_O are connected to the common bus. This means only one device occupies the bus at a time while the LVDS drivers for all other devices 3-state. Unlike SDO and SYNC_O, the clock cannot be switched out from device to device as the receiver requires a continuous clock. So only device 1 outputs the clock and CLK_O of all other devices is 3-stated by appropriately setting M1+ and M1- as listed in [Table 1](#).

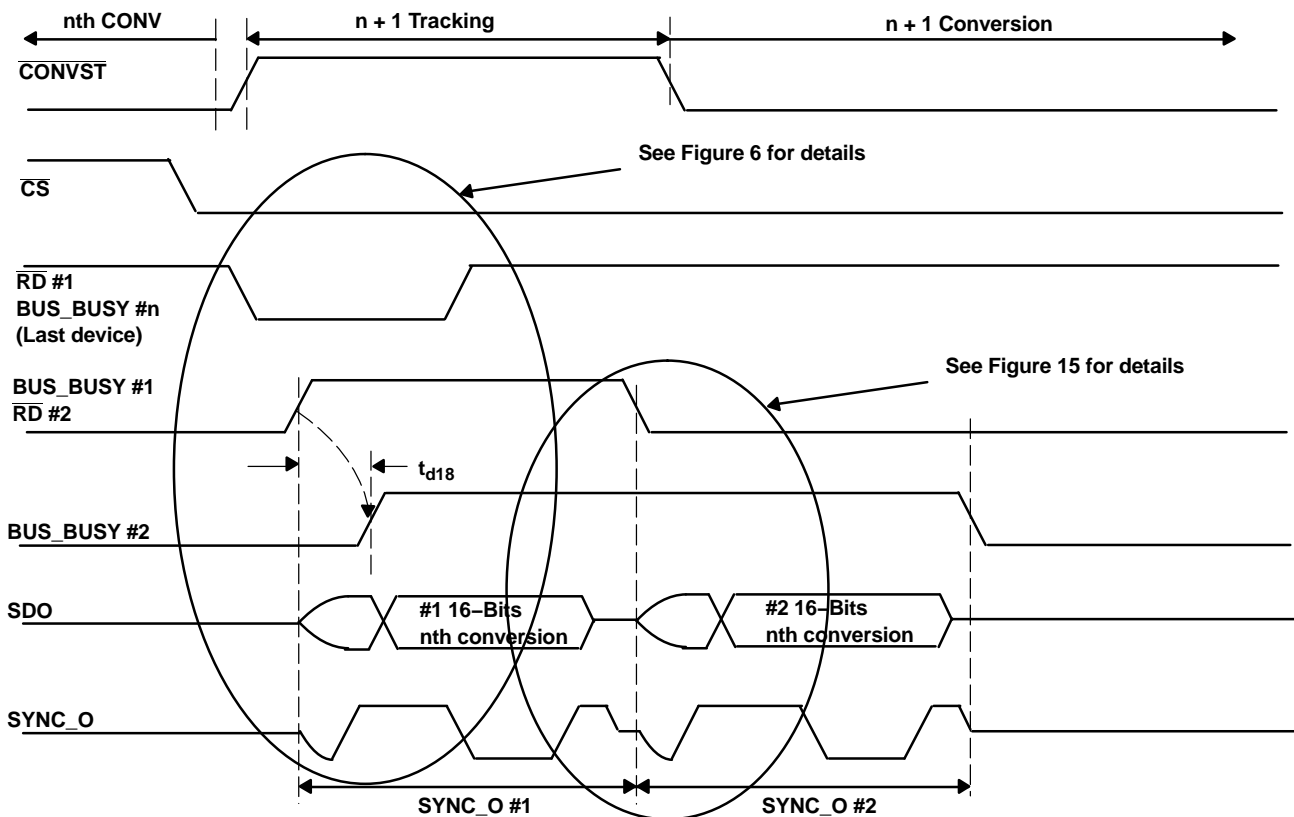

Figure 14. Data Read Operation for Devices in Cascade Mode

DATA READ OPERATION

On power up, BUS_BUSY for all of the devices is low. The devices receive $\overline{\text{CONVST}}$ or $\overline{\text{CSTART}}$ to sample and start the conversion. The first device starts the data read cycle at the end of its conversion. BUS_BUSY of device 1 (connected to $\overline{\text{RD}}$ of device 2) goes high on the read cycle start indicating that it wants to occupy the bus. Device 2 BUS_BUSY goes high on the rising edge of $\overline{\text{RD}}$. This propagates until the last device.

Device 1 BUS_BUSY goes low after it outputs its data; at this time SDO and SYNC_O for device 1 go to 3-state. The falling edge of BUS_BUSY ($\overline{\text{RD}}$ of the next device) indicates to the next device that it is its turn to output the data. The next device outputs the data from the last completed conversion. BUS_BUSY of the last device goes low and its SYNC_O and SDO go to 3-state after it outputs its data. BUS_BUSY of the last device is fed back to $\overline{\text{RD}}$ of the first device as shown in Figure 13 ($\overline{\text{RD}}$ can also be tied to 0 for device 1). This ensures that $\overline{\text{RD}}$ of device 1 is low before its conversion is over. The data read sequence continues with only one external signal, $\overline{\text{CONVST}}$ or $\overline{\text{CSTART}}$, when $\overline{\text{CS}} = 0$. For any device, $\overline{\text{CS}}$ high during the data read cycle 3-states SYNC_O and SDO of the device and halts the data read sequence. To reset this condition it is necessary to assert $\overline{\text{CS}}$ high for all of the devices. The new read sequence starts only after $\overline{\text{CS}}$ for all of the devices is low before point A shown in Figure 6. The high pulse on $\overline{\text{CS}}$ must be at least 20 ns wide. It is better to connect $\overline{\text{CS}}$ for all of the devices together to avoid undesired halting of the data read sequence.

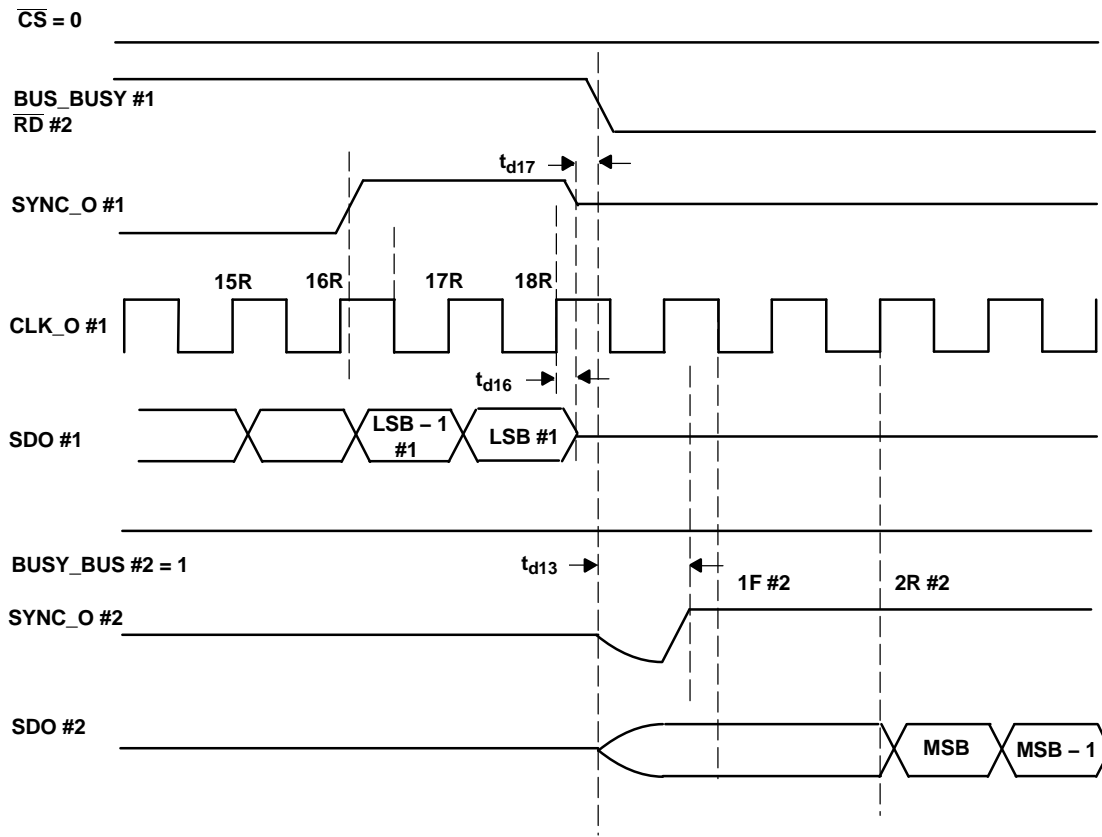

Figure 15. Device *n* Read Cycle End and Device *n+1* Read Cycle Start

Unlike daisy chain, the data frames of all the devices in cascade are not seamless and there is a loss of time between one device 3-state to other device data valid due to wakeup time from 3-state and a two clock phase shift between SYNC and data (see Figure 15 for details). As a result, the number of data frames per second in this mode are less than in daisy chain mode. Also, a maximum of 4 devices can be cascaded on the same bus. But, I/O power per device is considerably lower in cascade as compared to daisy chain as each device LVDS o/p goes to 3-state after its data transfer. The deserializer at the output of the last device can shift the data on every clock falling edge, and it can latch the parallel 16-bit word on the second CLK_O rising edge (shown as 18R) after every SYNC_O rising edge.

THEORY OF OPERATION

The ADS8410 is a member of the high-speed successive approximation register (SAR) analog-to-digital converters family. The architecture is based on charge redistribution, which inherently includes a sample/hold function. The device includes a built-in conversion clock, internal reference, and 200-MHz LVDS serial interface. The device can be operated at maximum throughput of 2 MSPS.

ANALOG INPUT

An analog input is provided to two input pins: +IN and -IN. When a conversion is initiated, the voltage difference between these pins is sampled on the internal capacitor array. While a conversion is in progress, both inputs are disconnected from any internal function.

THEORY OF OPERATION (continued)

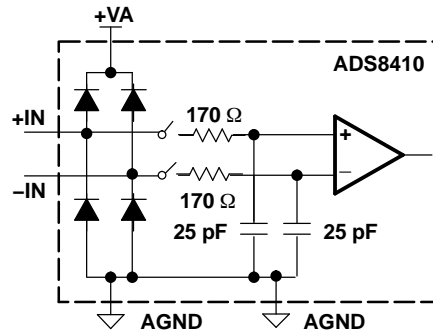

Figure 16. Simplified Input Circuit

When the converter enters hold mode, the voltage difference between the +IN and -IN inputs is captured on the internal capacitor array. The input current on the analog inputs depends upon a number of factors: sample rate, input voltage, signal frequency, and source impedance. Essentially, the current into the ADS8410 charges the internal capacitor array during the sample period. After this capacitance has been fully charged, there is no further input current (this may not happen when the signal is moving continuously). The source of the analog input voltage must be able to charge the input capacitance (25 pF) to better than a 16-bit settling level with a step input within the acquisition time of the device. For calculation, the step size can be selected equal to the maximum voltage difference between two consecutive samples at the maximum signal frequency (see the TYPICAL ANALOG INPUT CIRCUIT section). When the converter goes into hold mode, the input impedance is greater than 1GΩ.

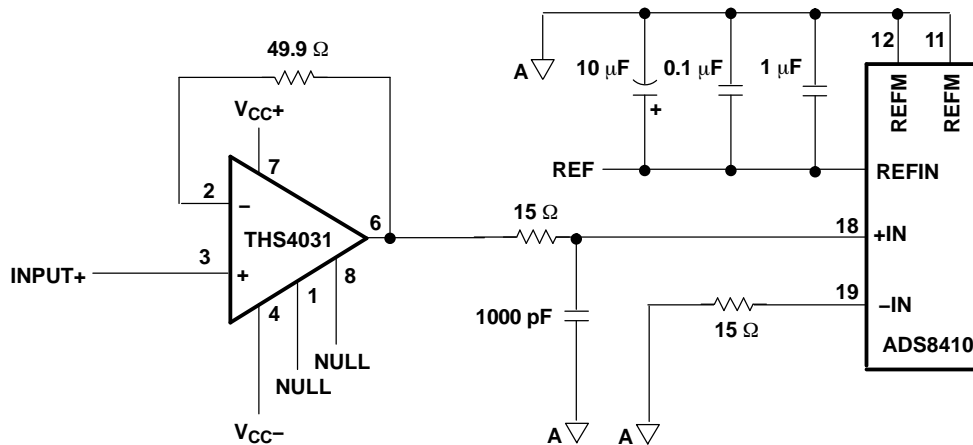

Figure 17. Typical Analog Input Schematic

Care must be taken regarding the absolute analog input voltage. To maintain the linearity of the converter, both -IN and +IN inputs should be within the limits specified. Outside of these ranges, the converter linearity may not meet specifications. Care should be taken to ensure that +IN and -IN see the same impedance to the respective sources. If this is not observed, the two inputs could have different settling times. This may result in offset error, gain error, and linearity error which changes with temperature and input voltage.

REFERENCE

The ADS8410 has a built-in 4.096-V (nominal value) reference. The ADS8410 can also operate with an external reference. When the internal reference is used, pin 14 (REFOUT) should be connected to pin 13 (REFIN), and a 0.1-μF decoupling capacitor and 1-μF storage capacitor must be connected between pin 14 (REFOUT) and pins 11 and 12 (REFM) (see Figure 18). The internal reference of the converter is buffered.

THEORY OF OPERATION (continued)

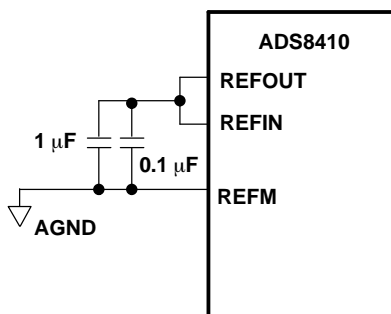

Figure 18. Using Internal Reference

The REFIN pin is also internally buffered. This eliminates the need to put a high bandwidth buffer onboard to drive the ADC reference and saves system area and power. When an external reference is used, the reference must be low noise, which can be achieved by the additional bypass capacitor from the REFIN pin to the REFM pin (see Figure 19). REFM must be connected to the analog ground plane.

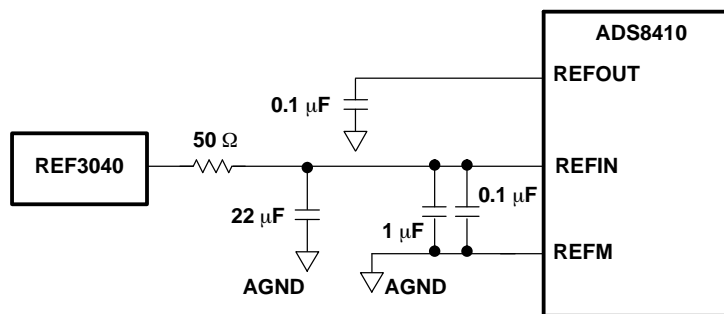

Figure 19. Using External Reference

DIGITAL INTERFACE

TIMING AND CONTROL

Refer to the timing diagrams and TIMING REQUIREMENTS table for detailed information.

SAMPLING AND CONVERSION

Sampling and conversion is controlled by the $\overline{\text{CONVST}}$ pin. For higher noise performance it is essential to have low jitter on the falling edge of $\overline{\text{CONVST}}$. The device uses the internally generated clock for conversion, hence it has a fixed conversion time.

READING DATA

The ADS8410 includes a high-speed LVDS serial interface. As discussed prior, an external clock (CLK_I, less than 200 MHz) or an internal 200-MHz clock can be used for a data read. The device outputs data in two's complement format. Table 3 lists the ideal output codes.

Table 3. Ideal Input Voltages and Output Codes

DESCRIPTION	ANALOG VALUE (+IN – (–IN))	HEX CODE
Full-scale range	$+V_{\text{ref}}$	–
Least significant bit (LSB)	$+V_{\text{ref}}/2^{16}$	–
Full scale	$V_{\text{ref}} - 1 \text{ LSB}$	FFFF
Midscale	$+V_{\text{ref}}/2$	8000

Table 3. Ideal Input Voltages and Output Codes (continued)

DESCRIPTION	ANALOG VALUE (+IN – (–IN))	HEX CODE
Midscale – 1 LSB	$V_{ref}/2 - 1 \text{ LSB}$	7FFF
Zero	0 V	0000

The restrictions on read cycle start are described in the section RESTRICTIONS ON READ CYCLE START (see Figure 9).

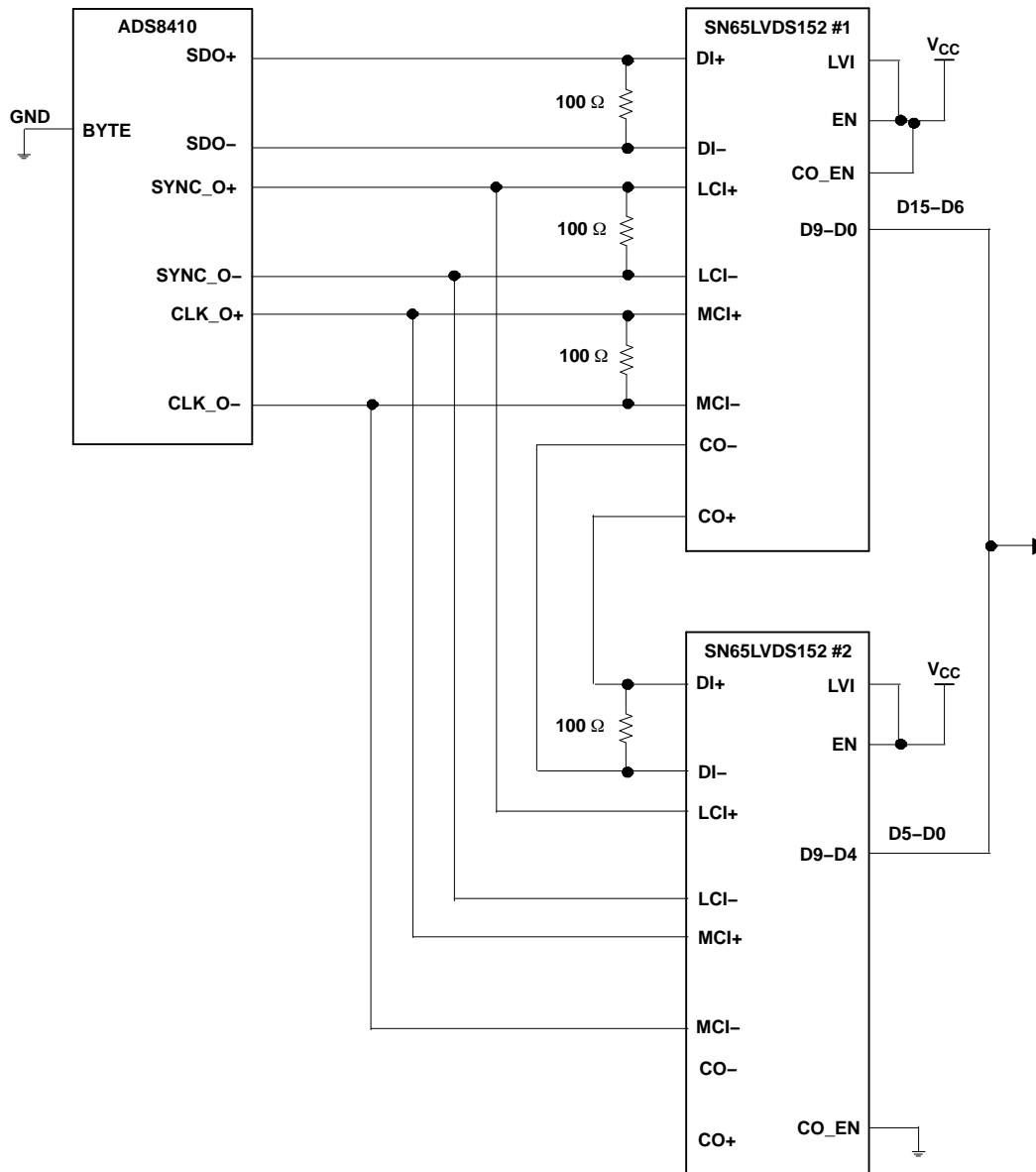

Figure 20. 16-Bit Data De-Serialization While BYTE = 0

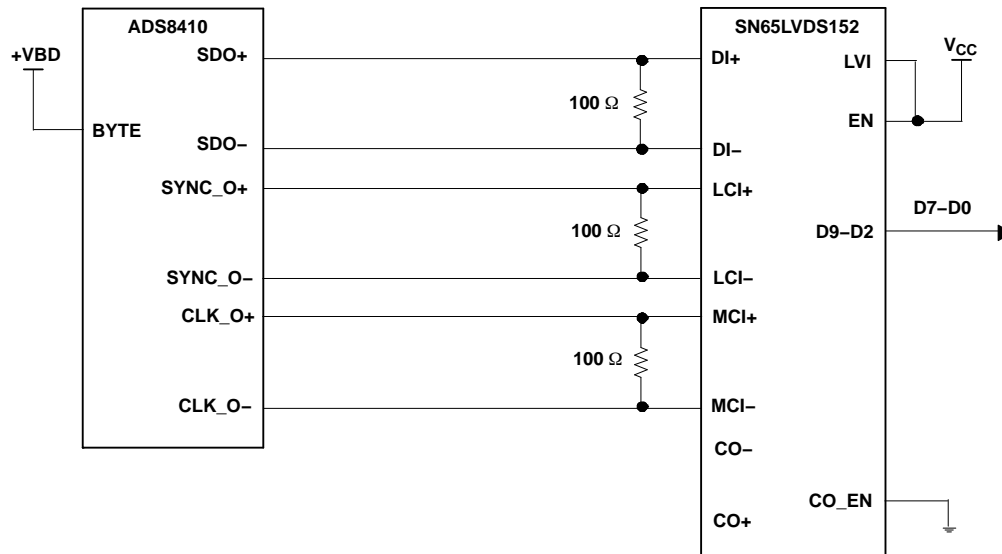

Figure 21. 8-Bit Data De-Serialization While BYTE = 1, Data

POWER SAVING

The converter provides two power saving modes, full powerdown and nap. Table 4 lists information on the activation/deactivation and resumption times for both modes.

Table 4. Powerdown Modes

POWERDOWN MODE	SDO	POWER CONSUMPTION	ACTIVATED BY	ACTIVATION TIME	RESUME POWER BY
Normal operation	Refer to DATA READ OPERATION section	58 mA	NA	NA	NA
Full powerdown (internal reference)	3 Stated	1 μ A	$\overline{PD} = 0$	t_{d21}	$\overline{PD} = 1$
Full powerdown (external reference)	3 Stated	1 μ A	$\overline{PD} = 0$	t_{d21}	$\overline{PD} = 1$
Nap powerdown	Not 3 stated	25 mA	Nap = 1	150 ns	Sample start

FULL POWERDOWN MODE

Full powerdown mode is activated by deasserting $\overline{PD} = 0$; the device takes t_{d21} ns to reach the full powerdown state. The device can return to normal mode from full powerdown by asserting $\overline{PD} = 1$. The powerup sequence is different for device operation with an internal reference or external reference as shown in Figure 22 and Figure 23.

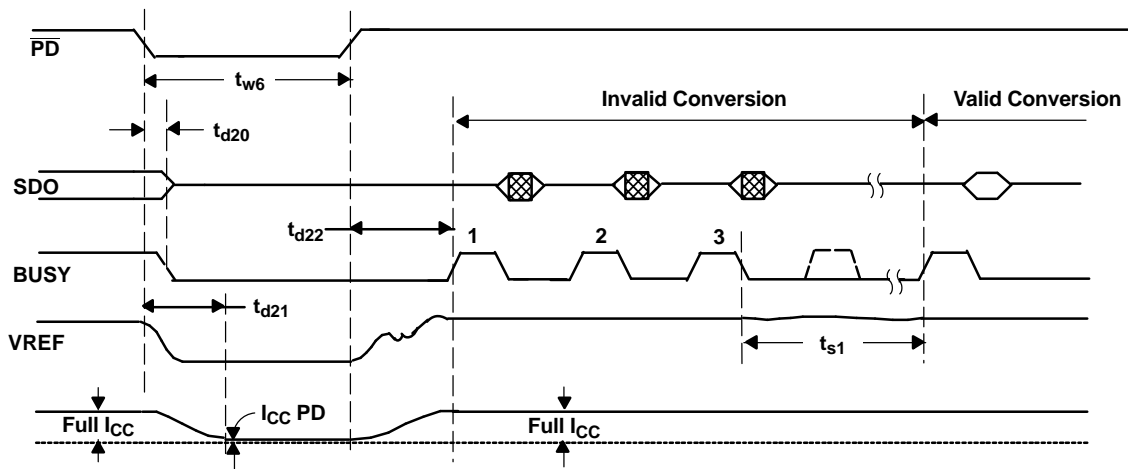

Figure 22. Device Full Powerdown and Powerup Sequence with Device Operation in Internal Reference Mode

When an internal reference is used, a conversion can be started t_{d22} ns after asserting $\overline{PD} = 1$. After the first three conversions, t_{s1} ns are required for reference voltage settling to the trimmed value. Any conversions after this provide data at the specified accuracy.

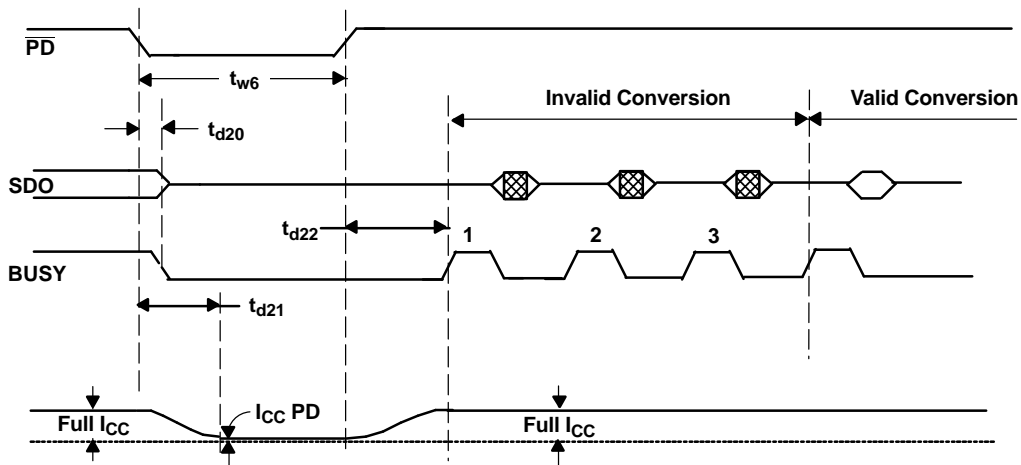

Figure 23. Device Full Powerdown and Powerup Sequence with Device Operation in External Reference Mode

When an external reference is used, a conversion can be started t_{d22} ns after asserting $\overline{PD} = 1$. The first three conversions are required for internal circuit stabilization. Any conversions after this provide data at the specified accuracy.

NAP MODE

The device automatically enters the nap state if $nap = 1$ at end of a conversion, and it remains in the nap state until the start of the sampling phase. A minimum of 150 ns is required after a sample start for the device to come out of the nap state and to perform normal sampling. So the minimum sampling time needed for nap mode is $t_{acq(min)} + 150$ ns, or the maximum conversion speed in nap mode is 1.5 MHz.

LAYOUT

For optimum performance, care should be taken with the physical layout of the ADS8410 circuitry. The device offers single-supply operation, and it is often used in close proximity with digital logic, FPGA, microcontrollers, microprocessors, and digital signal processors. The more digital logic present in the design and the higher the switching speed, the more difficult it is to achieve good performance from the converter.

The basic SAR architecture is sensitive to glitches or sudden changes on the power supply, reference, ground connections, and digital inputs that occur just prior to the end of sampling and just prior to latching the output of the analog comparator during the conversion phase. Such glitches might originate from switching power supplies, nearby digital logic, or high power devices. Noise during the end of sampling and the later half of a conversion must be kept to a minimum (the former half of a conversion is not very sensitive since the device uses a proprietary error correction algorithm to correct for transient errors during this period).

The degree of error in the digital output depends on the reference voltage, layout, and the exact timing of the external event. On average, the device draws very little current from an external reference as the reference voltage is internally buffered. If the reference voltage is external and originates from an op amp, make sure that it can drive the bypass capacitor or capacitors without oscillation. A 0.1- μ F bypass capacitor and 1- μ F storage capacitor are recommended from REFIN directly to REFM.

The AGND and BDGND pins should be connected to a clean ground point. In all cases, this should be the analog ground. Avoid connections that are too close to the grounding point of a microcontroller or digital signal processor. If required, run a ground trace directly from the converter to the power supply entry point. The ideal layout consists of an analog ground plane dedicated to the converter and associated analog circuitry.

As with the AGND connections, +VA should be connected to a +5-V power supply plane that is separate from the connection for +VBD and digital logic until they are connected at the power entry point onto the PCB. Power to the ADC should be clean and well bypassed. A 0.1- μ F ceramic bypass capacitor should be placed as close to the device as possible. See Table 5 for the placement of the capacitor. In addition to the 0.1- μ F capacitor, a 1- μ F capacitor is recommended. In some situations, additional bypassing may be required, such as a 100- μ F electrolytic capacitor or even a Pi filter made up of inductors and capacitors; all designed to essentially low-pass filter the +5-V supply, thus removing the high frequency noise.

Table 5. Power Supply Decoupling Capacitor Placement

POWER SUPPLY PLANE	CONVERTER ANALOG SIDE	CONVERTER DIGITAL SIDE
SUPPLY PINS		
Pair of pins require a shortest path to decoupling capacitors	(9,10) (16,17) (20,21) (22,23) (26,27 or 25,26) (36,37)	(44,45)

TYPICAL CHARACTERISTICS

HISTOGRAM (DC CODE SPREAD AT THE CENTER OF CODE)

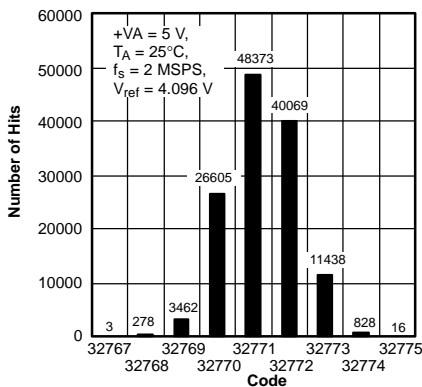

Figure 24.

HISTOGRAM (DC CODE SPREAD WITH I/P CLOSE TO FS)

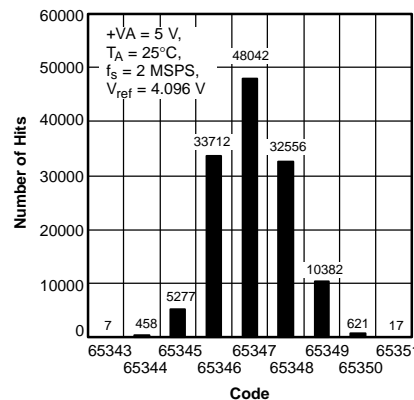

Figure 25.

EFFECTIVE NUMBER OF BITS VS FREE-AIR TEMPERATURE

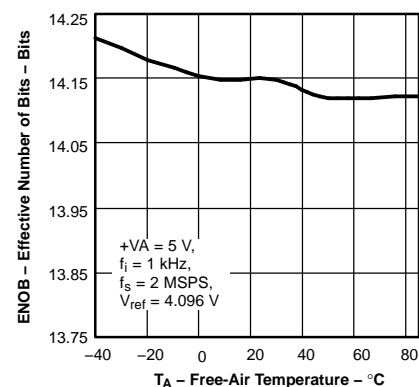

Figure 26.

TYPICAL CHARACTERISTICS (continued)

**SIGNAL-TO-NOISE AND DISTORTION
VS
FREE-AIR TEMPERATURE**

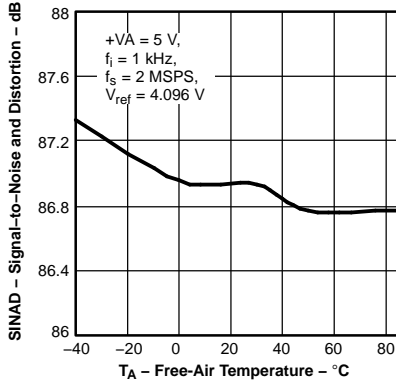

Figure 27.

**SIGNAL-TO-NOISE RATIO
VS
FREE-AIR TEMPERATURE**

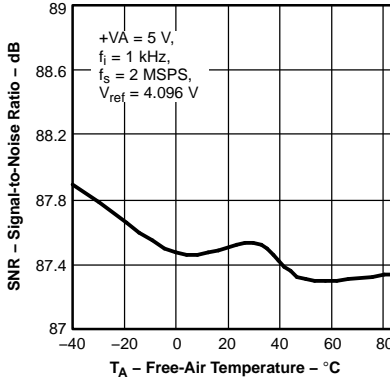

Figure 28.

**SPURIOUS FREE DYNAMIC RANGE
VS
FREE-AIR TEMPERATURE**

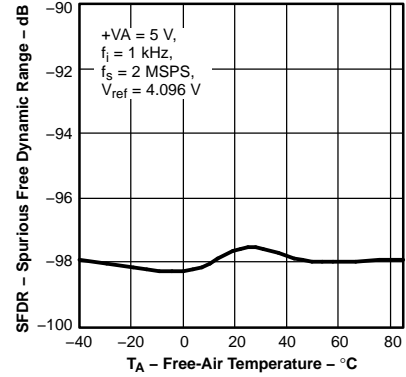

Figure 29.

**TOTAL HARMONIC DISTORTION
VS
FREE-AIR TEMPERATURE**

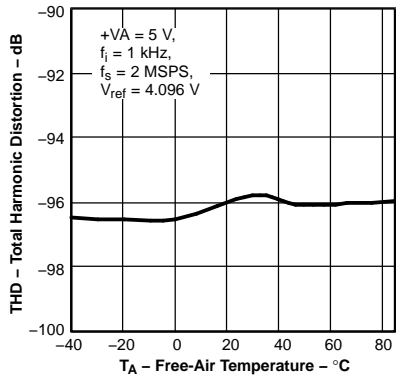

Figure 30.

**EFFECTIVE NUMBER OF BITS
VS
INPUT FREQUENCY**

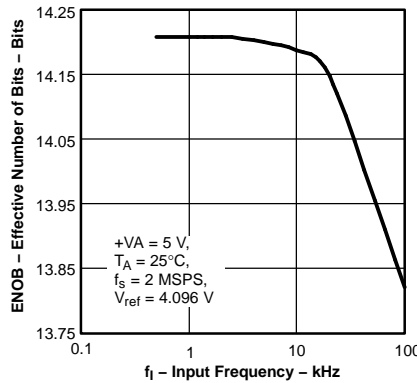

Figure 31.

**SIGNAL-TO-NOISE AND DISTORTION
VS
INPUT FREQUENCY**

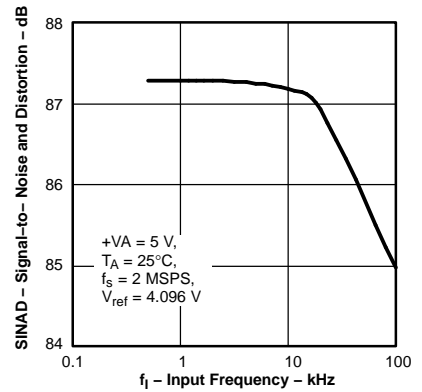

Figure 32.

**SIGNAL-TO-NOISE RATIO
VS
INPUT FREQUENCY**

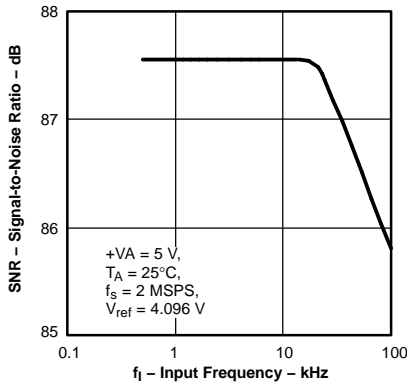

Figure 33.

**SPURIOUS FREE DYNAMIC RANGE
VS
INPUT FREQUENCY**

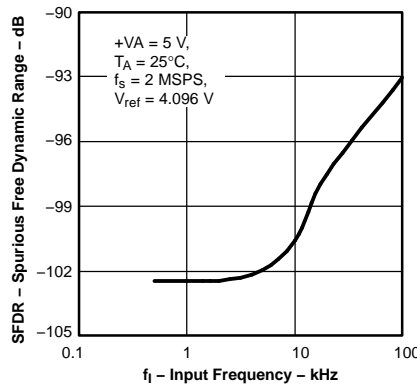

Figure 34.

**TOTAL HARMONIC DISTORTION
VS
INPUT FREQUENCY**

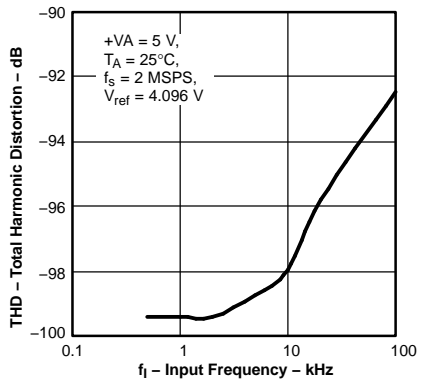

Figure 35.

TYPICAL CHARACTERISTICS (continued)

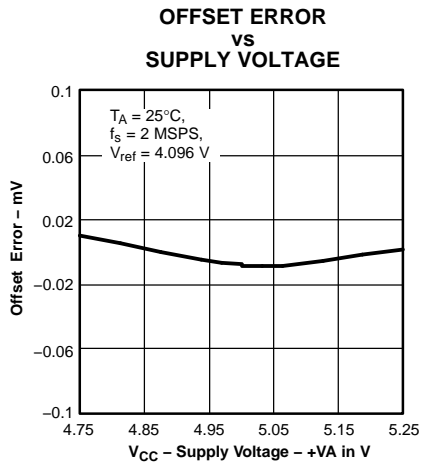

Figure 36.

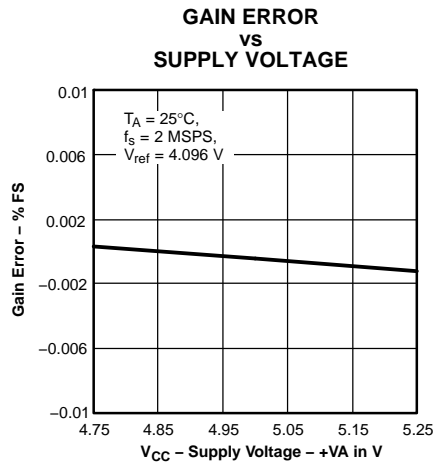

Figure 37.

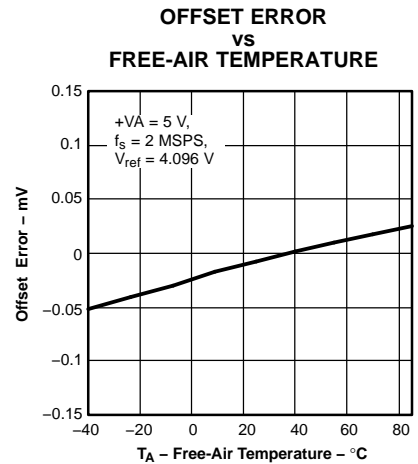

Figure 38.

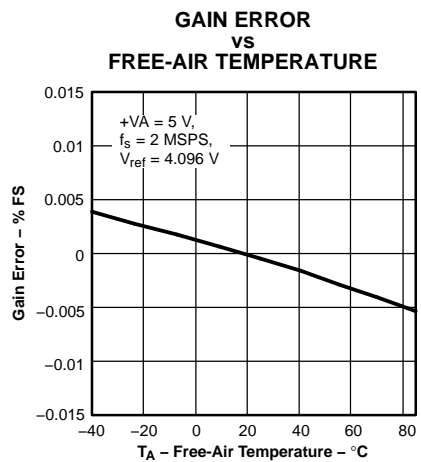

Figure 39.

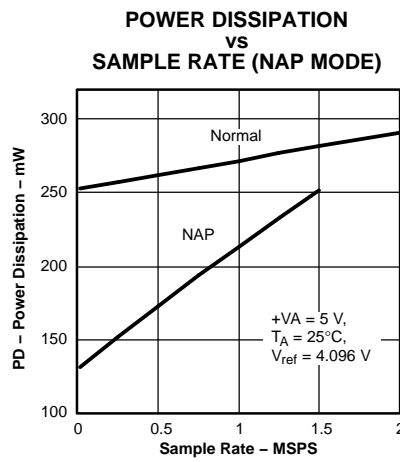

Figure 40.

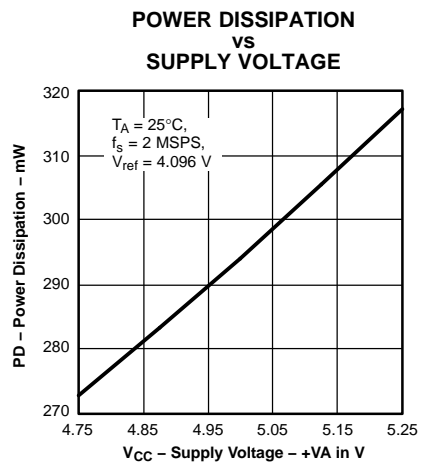

Figure 41.

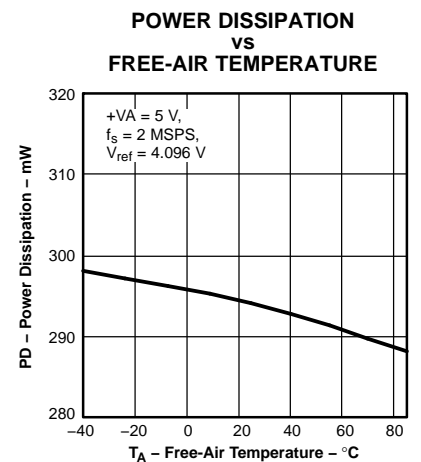

Figure 42.

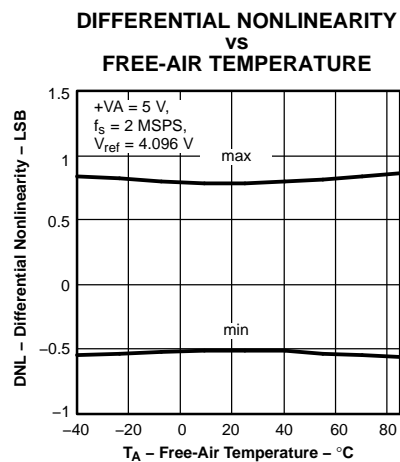

Figure 43.

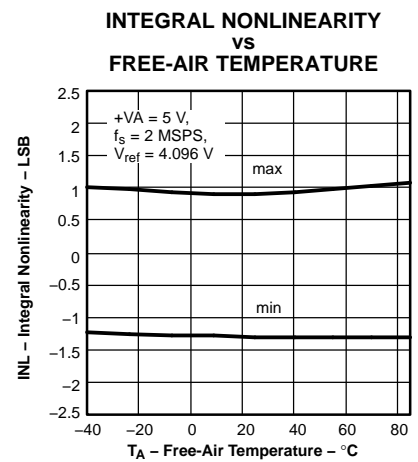

Figure 44.

TYPICAL CHARACTERISTICS (continued)

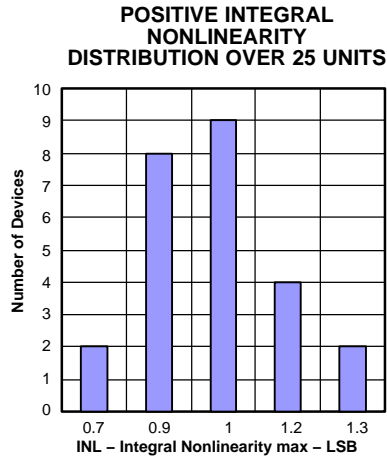

Figure 45.

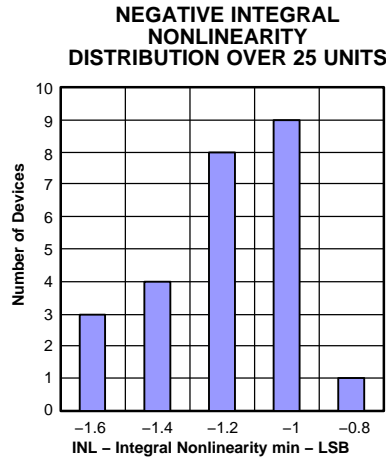

Figure 46.

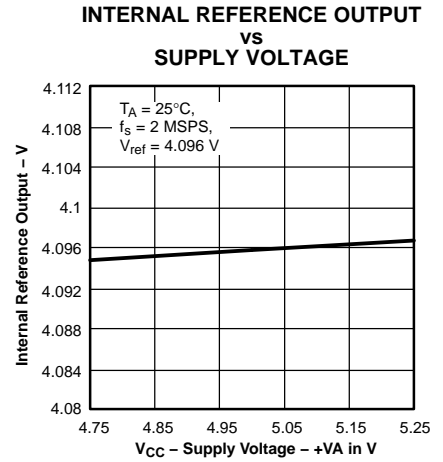

Figure 47.

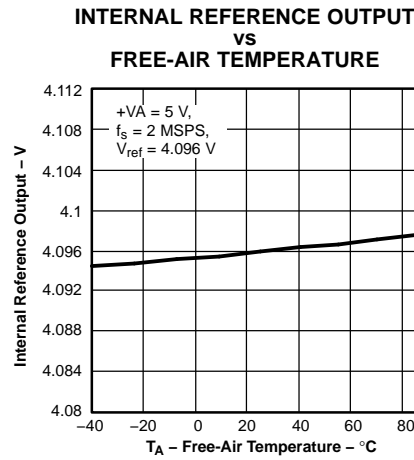

Figure 48.

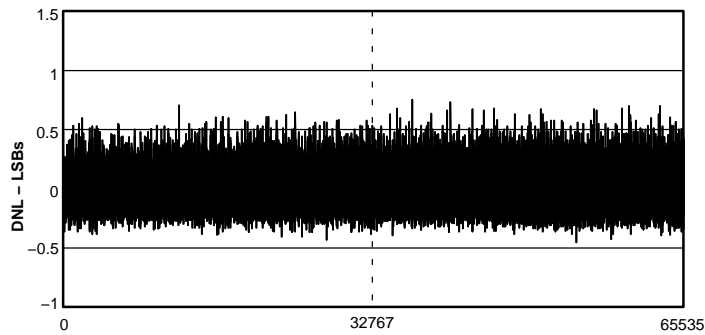

Figure 49. Typical DNL

TYPICAL CHARACTERISTICS (continued)

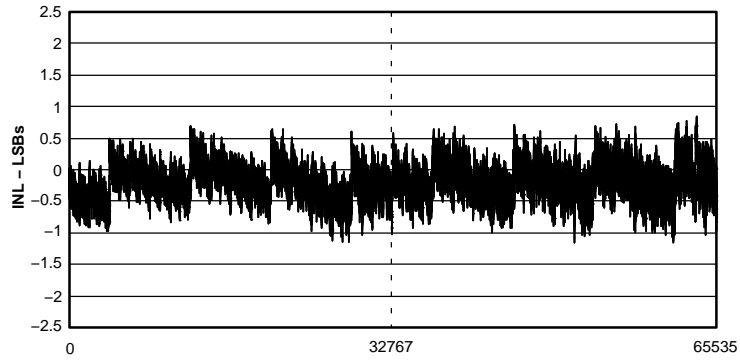

Figure 50. Typical INL

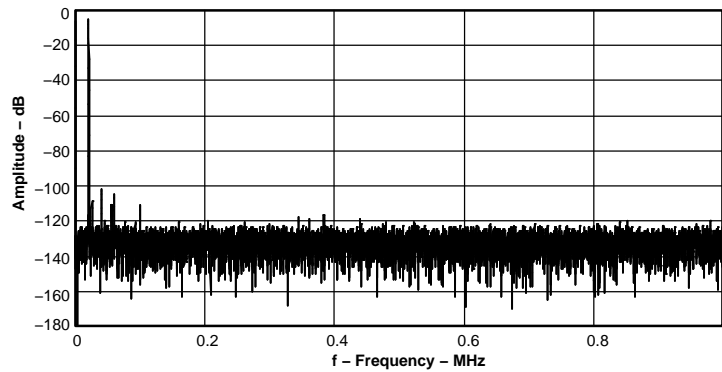

Figure 51. Typical FFT

PARAMETER MEASUREMENT INFORMATION

DRIVER

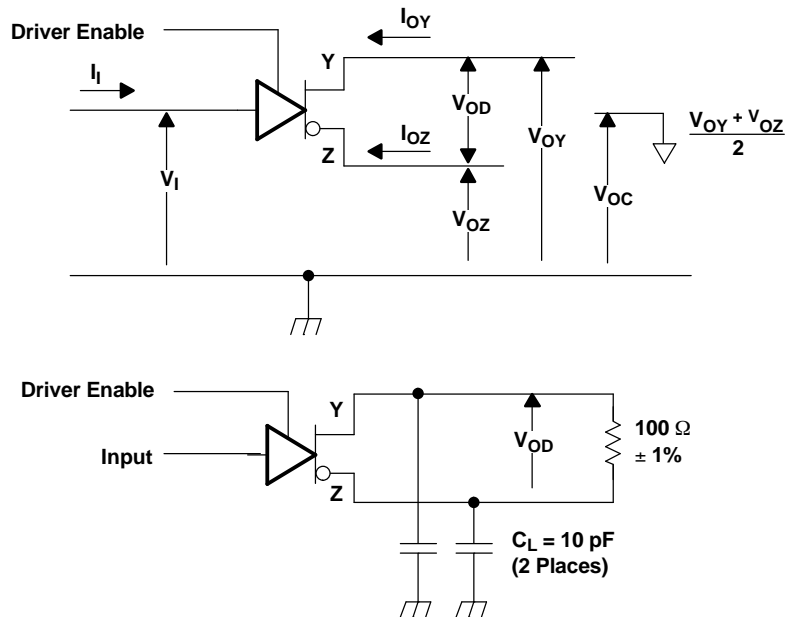

Figure 52. Driver Voltage and Current Definitions

PARAMETER MEASUREMENT INFORMATION (continued)

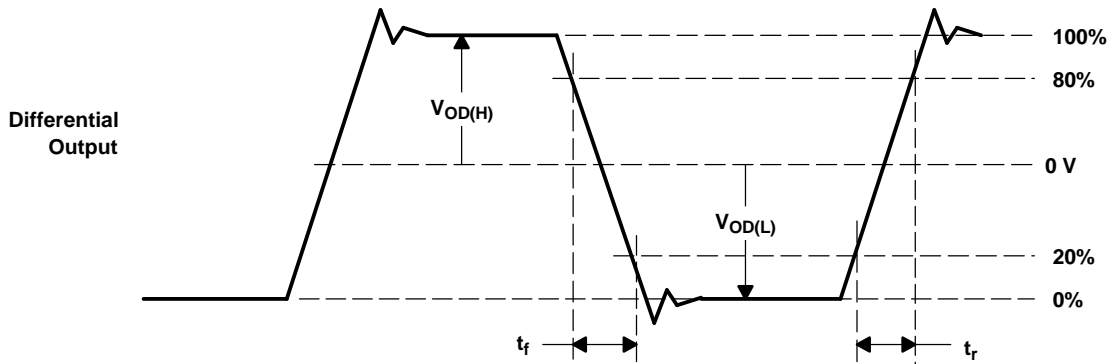

Figure 53. Timing and Voltage Definitions of the Differential Output Signal

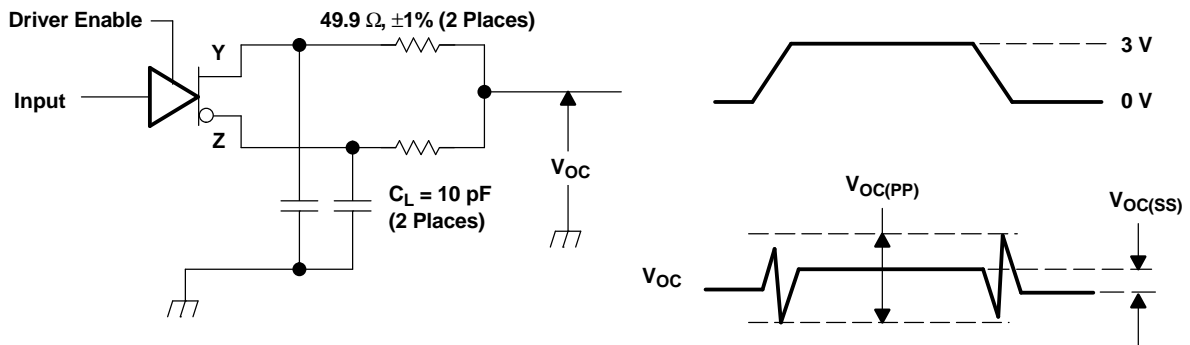

Figure 54. Test Circuit and Definitions for the Driver Common-Mode Output Voltage

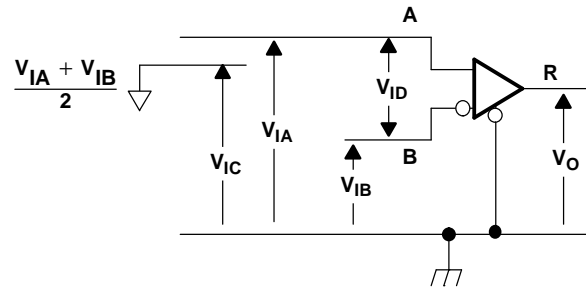

Figure 55. Receiver Voltage Definitions

PACKAGING INFORMATION

Orderable Device	Status ⁽¹⁾	Package Type	Package Drawing	Pins	Package Qty	Eco Plan ⁽²⁾	Lead/Ball Finish	MSL Peak Temp ⁽³⁾
ADS8410IBRGZR	ACTIVE	VQFN	RGZ	48	2500	Green (RoHS & no Sb/Br)	CU NIPDAU	Level-2-260C-1 YEAR
ADS8410IBRGZRG4	ACTIVE	VQFN	RGZ	48	2500	Green (RoHS & no Sb/Br)	CU NIPDAU	Level-2-260C-1 YEAR
ADS8410IBRGZT	ACTIVE	VQFN	RGZ	48	250	Green (RoHS & no Sb/Br)	CU NIPDAU	Level-2-260C-1 YEAR
ADS8410IBRGZTG4	ACTIVE	VQFN	RGZ	48	250	Green (RoHS & no Sb/Br)	CU NIPDAU	Level-2-260C-1 YEAR
ADS8410IRGZR	ACTIVE	VQFN	RGZ	48	2500	Green (RoHS & no Sb/Br)	CU NIPDAU	Level-2-260C-1 YEAR
ADS8410IRGZRG4	ACTIVE	VQFN	RGZ	48	2500	Green (RoHS & no Sb/Br)	CU NIPDAU	Level-2-260C-1 YEAR
ADS8410IRGZT	ACTIVE	VQFN	RGZ	48	250	Green (RoHS & no Sb/Br)	CU NIPDAU	Level-2-260C-1 YEAR
ADS8410IRGZTG4	ACTIVE	VQFN	RGZ	48	250	Green (RoHS & no Sb/Br)	CU NIPDAU	Level-2-260C-1 YEAR

⁽¹⁾ The marketing status values are defined as follows:

ACTIVE: Product device recommended for new designs.

LIFEBUY: TI has announced that the device will be discontinued, and a lifetime-buy period is in effect.

NRND: Not recommended for new designs. Device is in production to support existing customers, but TI does not recommend using this part in a new design.

PREVIEW: Device has been announced but is not in production. Samples may or may not be available.

OBSOLETE: TI has discontinued the production of the device.

⁽²⁾ Eco Plan - The planned eco-friendly classification: Pb-Free (RoHS), Pb-Free (RoHS Exempt), or Green (RoHS & no Sb/Br) - please check <http://www.ti.com/productcontent> for the latest availability information and additional product content details.

TBD: The Pb-Free/Green conversion plan has not been defined.

Pb-Free (RoHS): TI's terms "Lead-Free" or "Pb-Free" mean semiconductor products that are compatible with the current RoHS requirements for all 6 substances, including the requirement that lead not exceed 0.1% by weight in homogeneous materials. Where designed to be soldered at high temperatures, TI Pb-Free products are suitable for use in specified lead-free processes.

Pb-Free (RoHS Exempt): This component has a RoHS exemption for either 1) lead-based flip-chip solder bumps used between the die and package, or 2) lead-based die adhesive used between the die and leadframe. The component is otherwise considered Pb-Free (RoHS compatible) as defined above.

Green (RoHS & no Sb/Br): TI defines "Green" to mean Pb-Free (RoHS compatible), and free of Bromine (Br) and Antimony (Sb) based flame retardants (Br or Sb do not exceed 0.1% by weight in homogeneous material)

⁽³⁾ MSL, Peak Temp. -- The Moisture Sensitivity Level rating according to the JEDEC industry standard classifications, and peak solder temperature.

Important Information and Disclaimer: The information provided on this page represents TI's knowledge and belief as of the date that it is provided. TI bases its knowledge and belief on information provided by third parties, and makes no representation or warranty as to the accuracy of such information. Efforts are underway to better integrate information from third parties. TI has taken and continues to take reasonable steps to provide representative and accurate information but may not have conducted destructive testing or chemical analysis on incoming materials and chemicals. TI and TI suppliers consider certain information to be proprietary, and thus CAS numbers and other limited information may not be available for release.

In no event shall TI's liability arising out of such information exceed the total purchase price of the TI part(s) at issue in this document sold by TI to Customer on an annual basis.

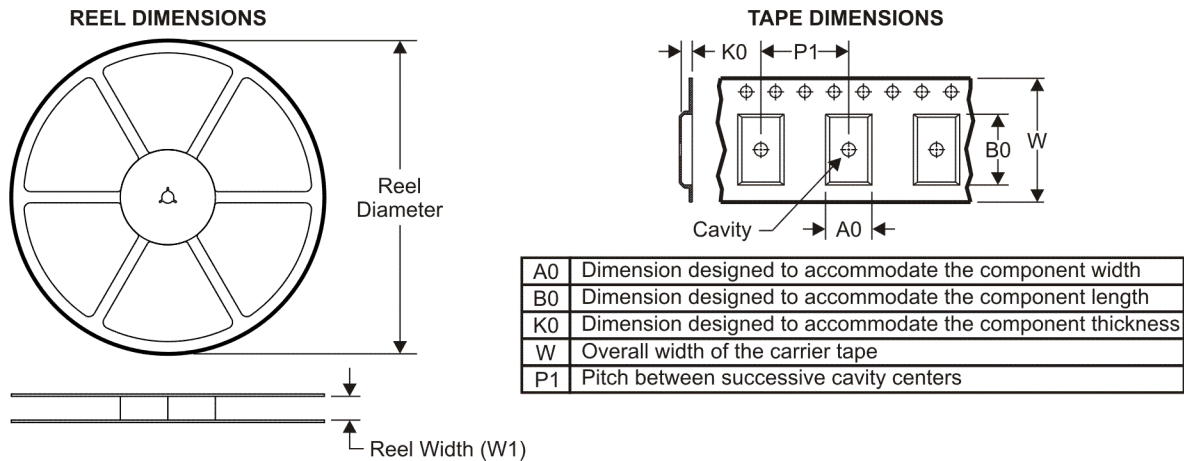
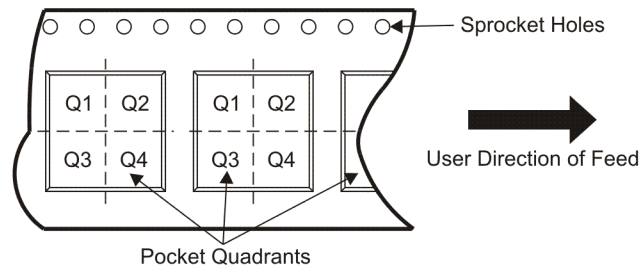
TAPE AND REEL INFORMATION

QUADRANT ASSIGNMENTS FOR PIN 1 ORIENTATION IN TAPE

*All dimensions are nominal

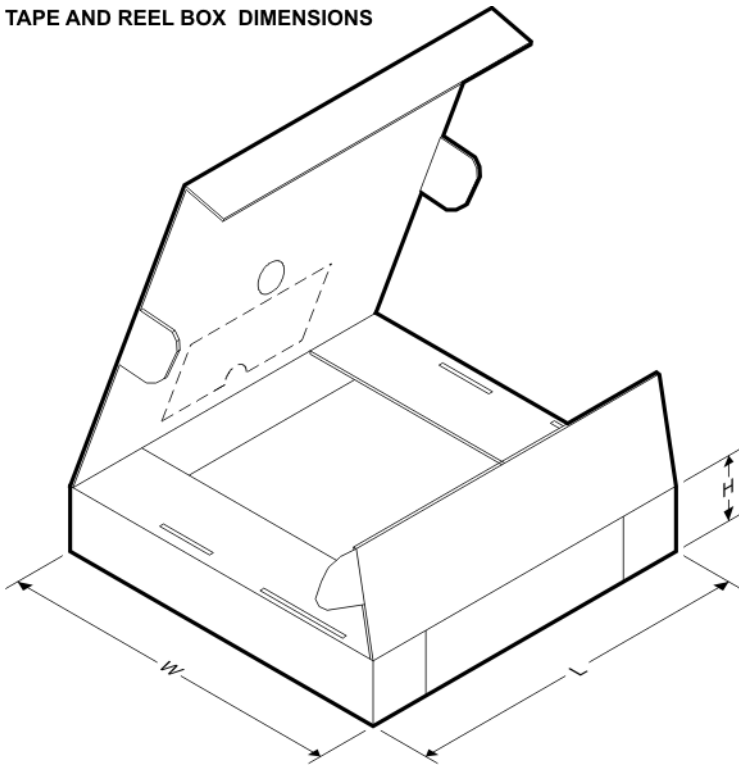
Device	Package Type	Package Drawing	Pins	SPQ	Reel Diameter (mm)	Reel Width W1 (mm)	A0 (mm)	B0 (mm)	K0 (mm)	P1 (mm)	W (mm)	Pin1 Quadrant
ADS8410IBRGZR	VQFN	RGZ	48	2500	330.0	16.4	7.3	7.3	1.5	12.0	16.0	Q2
ADS8410IBRGZT	VQFN	RGZ	48	250	330.0	16.4	7.3	7.3	1.5	12.0	16.0	Q2
ADS8410IRGZR	VQFN	RGZ	48	2500	330.0	16.4	7.3	7.3	1.5	12.0	16.0	Q2
ADS8410IRGZT	VQFN	RGZ	48	250	330.0	16.4	7.3	7.3	1.5	12.0	16.0	Q2

TAPE AND REEL BOX DIMENSIONS

*All dimensions are nominal

Device	Package Type	Package Drawing	Pins	SPQ	Length (mm)	Width (mm)	Height (mm)
ADS8410IBRGZR	VQFN	RGZ	48	2500	333.2	345.9	28.6
ADS8410IBRGZT	VQFN	RGZ	48	250	333.2	345.9	28.6
ADS8410IRGZR	VQFN	RGZ	48	2500	333.2	345.9	28.6
ADS8410IRGZT	VQFN	RGZ	48	250	333.2	345.9	28.6

RGZ (S-PQFP-N48)

PLASTIC QUAD FLATPACK

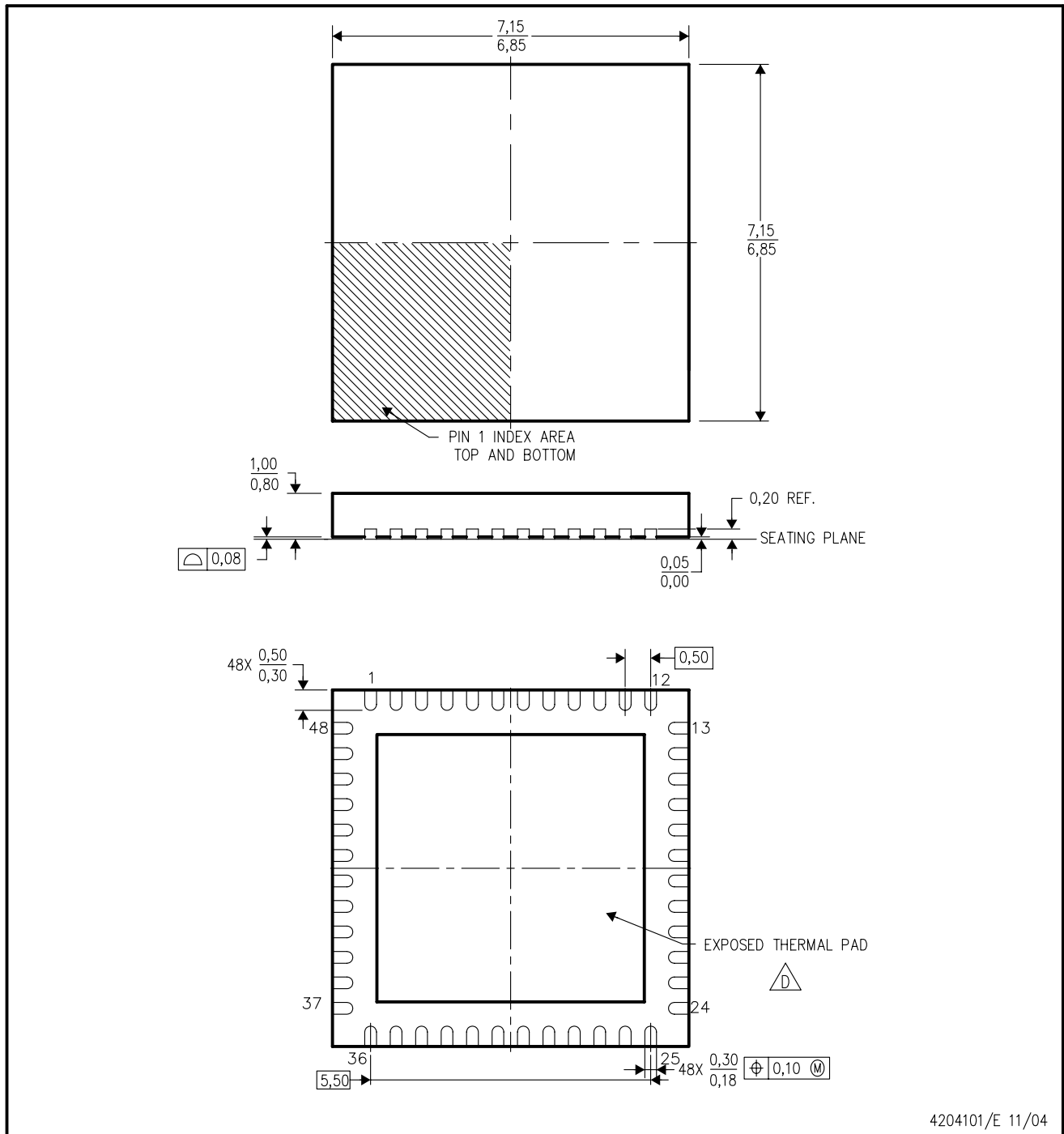

4204101/E 11/04

- NOTES:
- A. All linear dimensions are in millimeters. Dimensioning and tolerancing per ASME Y14.5M-1994.
 - B. This drawing is subject to change without notice.
 - C. Quad Flatpack, No-leads (QFN) package configuration.
 - D. The package thermal pad must be soldered to the board for thermal and mechanical performance. See the Product Data Sheet for details regarding the exposed thermal pad dimensions.
 - E. Falls within JEDEC MO-220.

THERMAL INFORMATION

This package incorporates an exposed thermal pad that is designed to be attached directly to an external heatsink. The thermal pad must be soldered directly to the printed circuit board (PCB). After soldering, the PCB can be used as a heatsink. In addition, through the use of thermal vias, the thermal pad can be attached directly to the appropriate copper plane shown in the electrical schematic for the device, or alternatively, can be attached to a special heatsink structure designed into the PCB. This design optimizes the heat transfer from the integrated circuit (IC).

For information on the Quad Flatpack No-Lead (QFN) package and its advantages, refer to Application Report, QFN/SON PCB Attachment, Texas Instruments Literature No. SLUA271. This document is available at www.ti.com.

The exposed thermal pad dimensions for this package are shown in the following illustration.

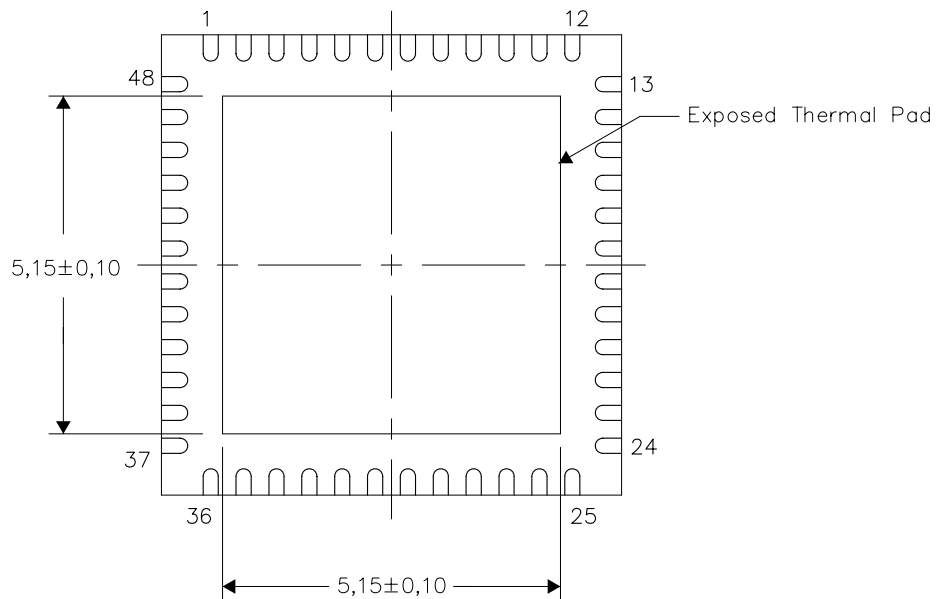

Bottom View

NOTE: All linear dimensions are in millimeters

Exposed Thermal Pad Dimensions

RGZ (S-PVQFN-N48)

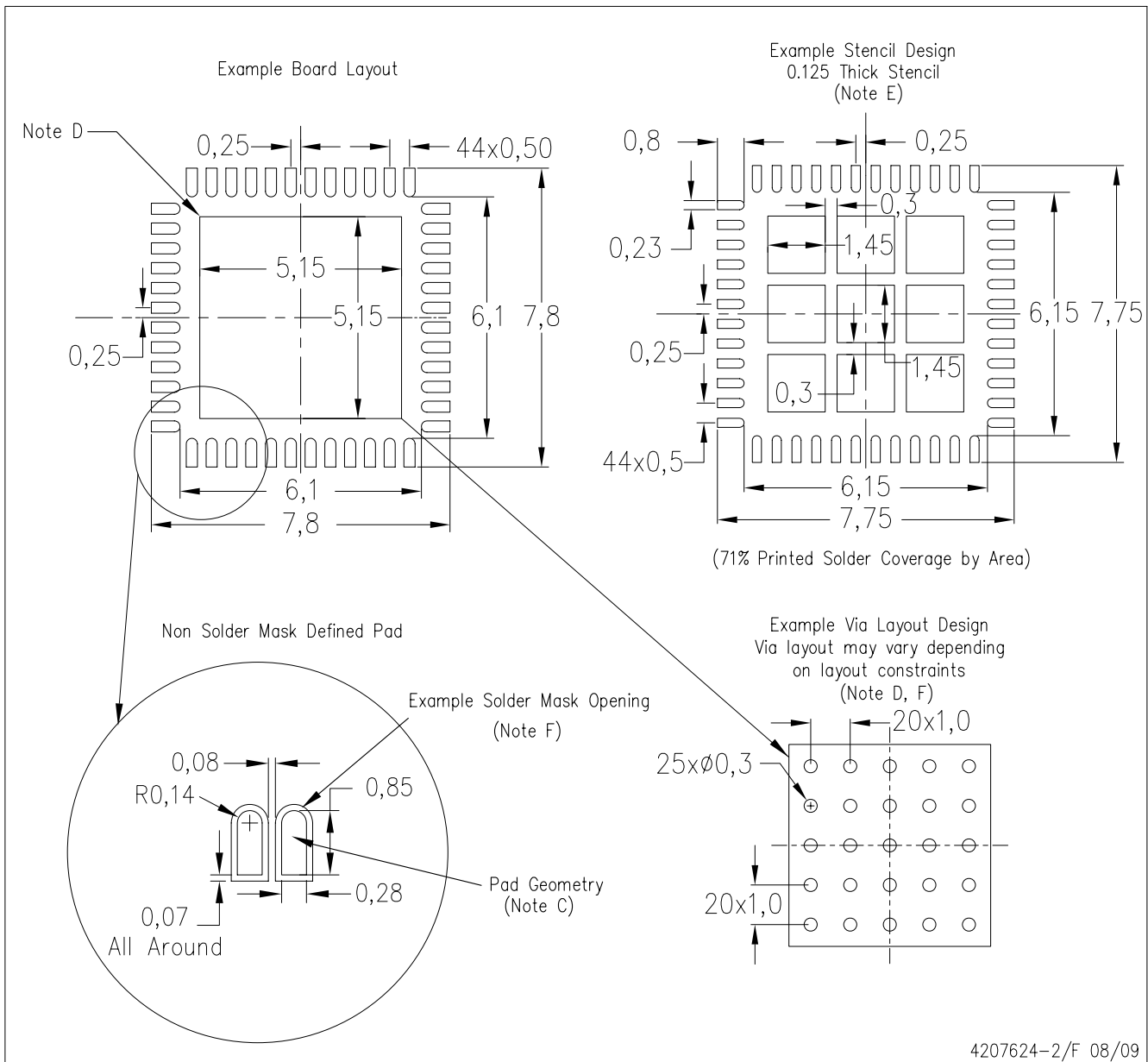

- NOTES:
- All linear dimensions are in millimeters.
 - This drawing is subject to change without notice.
 - Publication IPC-7351 is recommended for alternate designs.
 - This package is designed to be soldered to a thermal pad on the board. Refer to Application Note, Quad Flat-Pack Packages, Texas Instruments Literature No. SLUA271, and also the Product Data Sheets for specific thermal information, via requirements, and recommended board layout. These documents are available at www.ti.com <<http://www.ti.com>>.
 - Laser cutting apertures with trapezoidal walls and also rounding corners will offer better paste release. Customers should contact their board assembly site for stencil design recommendations. Refer to IPC 7525 for stencil design considerations.
 - Customers should contact their board fabrication site for recommended solder mask tolerances and via tenting recommendations for vias placed in the thermal pad.

IMPORTANT NOTICE

Texas Instruments Incorporated and its subsidiaries (TI) reserve the right to make corrections, modifications, enhancements, improvements, and other changes to its products and services at any time and to discontinue any product or service without notice. Customers should obtain the latest relevant information before placing orders and should verify that such information is current and complete. All products are sold subject to TI's terms and conditions of sale supplied at the time of order acknowledgment.

TI warrants performance of its hardware products to the specifications applicable at the time of sale in accordance with TI's standard warranty. Testing and other quality control techniques are used to the extent TI deems necessary to support this warranty. Except where mandated by government requirements, testing of all parameters of each product is not necessarily performed.

TI assumes no liability for applications assistance or customer product design. Customers are responsible for their products and applications using TI components. To minimize the risks associated with customer products and applications, customers should provide adequate design and operating safeguards.

TI does not warrant or represent that any license, either express or implied, is granted under any TI patent right, copyright, mask work right, or other TI intellectual property right relating to any combination, machine, or process in which TI products or services are used. Information published by TI regarding third-party products or services does not constitute a license from TI to use such products or services or a warranty or endorsement thereof. Use of such information may require a license from a third party under the patents or other intellectual property of the third party, or a license from TI under the patents or other intellectual property of TI.

Reproduction of TI information in TI data books or data sheets is permissible only if reproduction is without alteration and is accompanied by all associated warranties, conditions, limitations, and notices. Reproduction of this information with alteration is an unfair and deceptive business practice. TI is not responsible or liable for such altered documentation. Information of third parties may be subject to additional restrictions.

Resale of TI products or services with statements different from or beyond the parameters stated by TI for that product or service voids all express and any implied warranties for the associated TI product or service and is an unfair and deceptive business practice. TI is not responsible or liable for any such statements.

TI products are not authorized for use in safety-critical applications (such as life support) where a failure of the TI product would reasonably be expected to cause severe personal injury or death, unless officers of the parties have executed an agreement specifically governing such use. Buyers represent that they have all necessary expertise in the safety and regulatory ramifications of their applications, and acknowledge and agree that they are solely responsible for all legal, regulatory and safety-related requirements concerning their products and any use of TI products in such safety-critical applications, notwithstanding any applications-related information or support that may be provided by TI. Further, Buyers must fully indemnify TI and its representatives against any damages arising out of the use of TI products in such safety-critical applications.

TI products are neither designed nor intended for use in military/aerospace applications or environments unless the TI products are specifically designated by TI as military-grade or "enhanced plastic." Only products designated by TI as military-grade meet military specifications. Buyers acknowledge and agree that any such use of TI products which TI has not designated as military-grade is solely at the Buyer's risk, and that they are solely responsible for compliance with all legal and regulatory requirements in connection with such use.

TI products are neither designed nor intended for use in automotive applications or environments unless the specific TI products are designated by TI as compliant with ISO/TS 16949 requirements. Buyers acknowledge and agree that, if they use any non-designated products in automotive applications, TI will not be responsible for any failure to meet such requirements.

Following are URLs where you can obtain information on other Texas Instruments products and application solutions:

Products

Amplifiers	amplifier.ti.com
Data Converters	dataconverter.ti.com
DLP® Products	www.dlp.com
DSP	dsp.ti.com
Clocks and Timers	www.ti.com/clocks
Interface	interface.ti.com
Logic	logic.ti.com
Power Mgmt	power.ti.com
Microcontrollers	microcontroller.ti.com
RFID	www.ti-rfid.com
RF/IF and ZigBee® Solutions	www.ti.com/lprf

Applications

Audio	www.ti.com/audio
Automotive	www.ti.com/automotive
Broadband	www.ti.com/broadband
Digital Control	www.ti.com/digitalcontrol
Medical	www.ti.com/medical
Military	www.ti.com/military
Optical Networking	www.ti.com/opticalnetwork
Security	www.ti.com/security
Telephony	www.ti.com/telephony
Video & Imaging	www.ti.com/video
Wireless	www.ti.com/wireless

Mailing Address: Texas Instruments, Post Office Box 655303, Dallas, Texas 75265
Copyright © 2009, Texas Instruments Incorporated