

# SBD Type :11DQ10

## FEATURES

- \* Miniature Size
- \* Low Forward Voltage drop
- \* Low Power Loss, High Efficiency
- \* High Surge Capability
- \* 30 Volts thru 100 Volts Types Available
- \* 52mm Inside Tape Spacing Package Available

## OUTLINE DRAWING

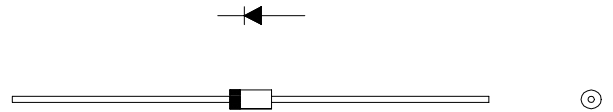

## Maximum Ratings

Approx Net Weight:0.32g

Rating		Symbol	11DQ10			Unit
Repetitive Peak Reverse Voltage		$V_{RRM}$	100			V
Average Rectified Output Current	Without Fin or P.C.Board	$I_O$	1.0	$T_a=35^{\circ}C^*$	50Hz Half Sine Wave Resistive Load	A
	P.C.Board mounted		1.0	$T_a=78^{\circ}C^*$		
RMS Forward Current		$I_{F(RMS)}$	1.57			A
Surge Forward Current		$I_{FSM}$	40	50Hz Half Sine Wave, 1cycle, Non-repetitive		A
Operating Junction Temperature Range		$T_{jw}$	- 40 to + 150			$^{\circ}C$
Storage Temperature Range		$T_{stg}$	- 40 to + 150			$^{\circ}C$

## Electrical • Thermal Characteristics

Characteristics	Symbol	Conditions	Min.	Typ.	Max.	Unit
Peak Reverse Current	$I_{RM}$	$T_j= 25^{\circ}C, V_{RM}= V_{RRM}$	-	-	0.5	mA
Peak Forward Voltage	$V_{FM}$	$T_j= 25^{\circ}C, I_{FM}= 1.0A$	-	-	0.85	V
Thermal Resistance (Junction to Ambient)	$R_{th(j-a)}$	Without Fin or P.C.Board	-	-	130	$^{\circ}C/W$
		P.C.Board mounted	-	-	81	

\*:Print Lands=5x5mm,Both Sides

11DQ10 OUTLINE DRAWING (Dimensions in mm)

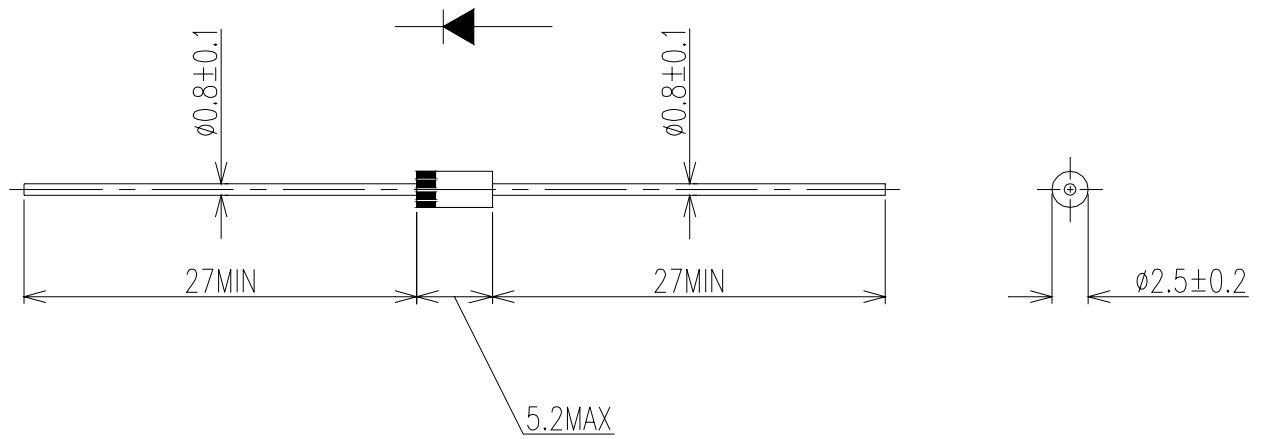

FORWARD CURRENT VS. VOLTAGE

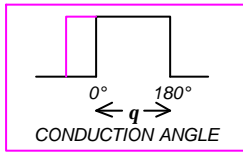
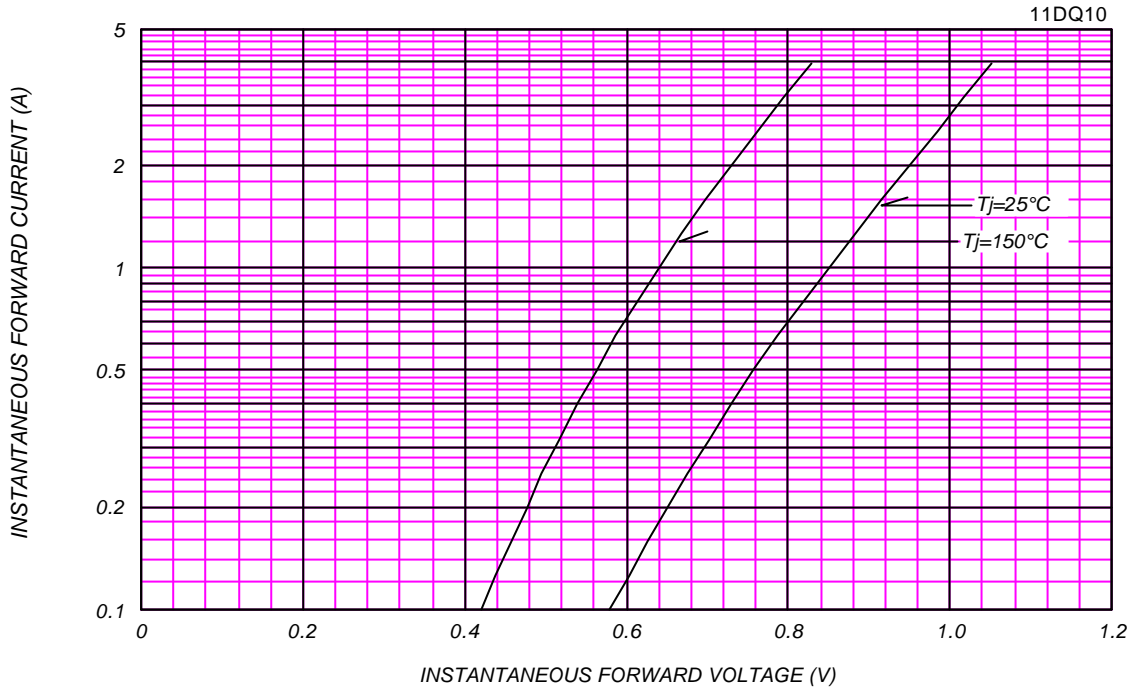

AVERAGE FORWARD POWER DISSIPATION

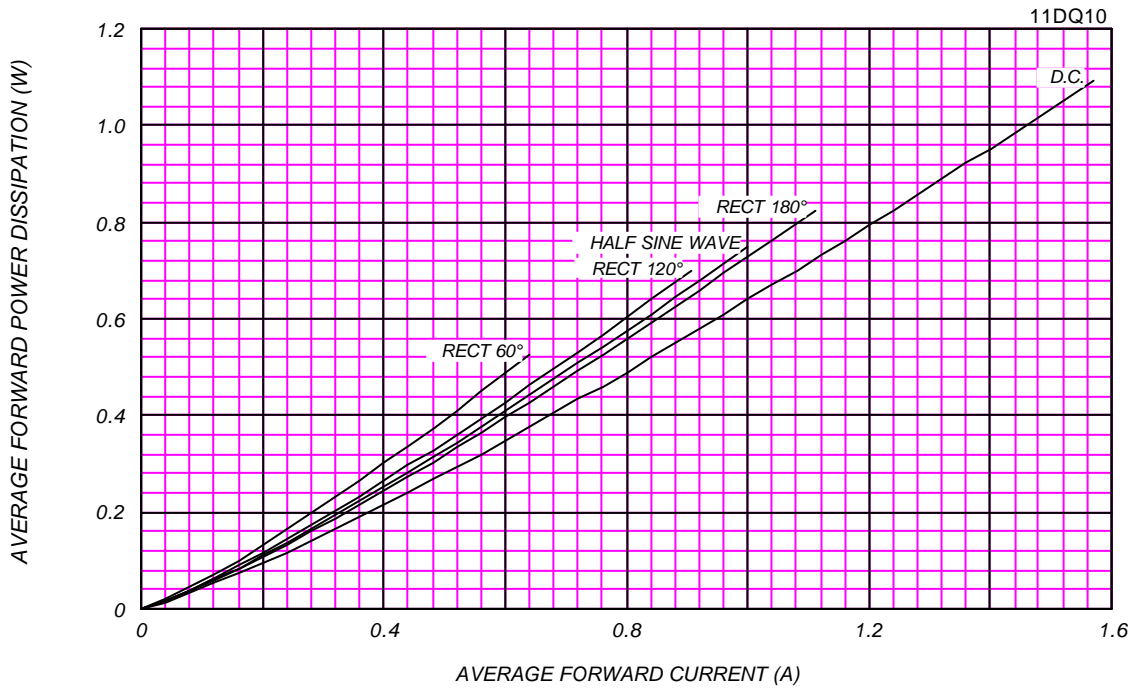

PEAK REVERSE CURRENT VS. PEAK REVERSE VOLTAGE

T<sub>j</sub> = 150 °C

11DQ10

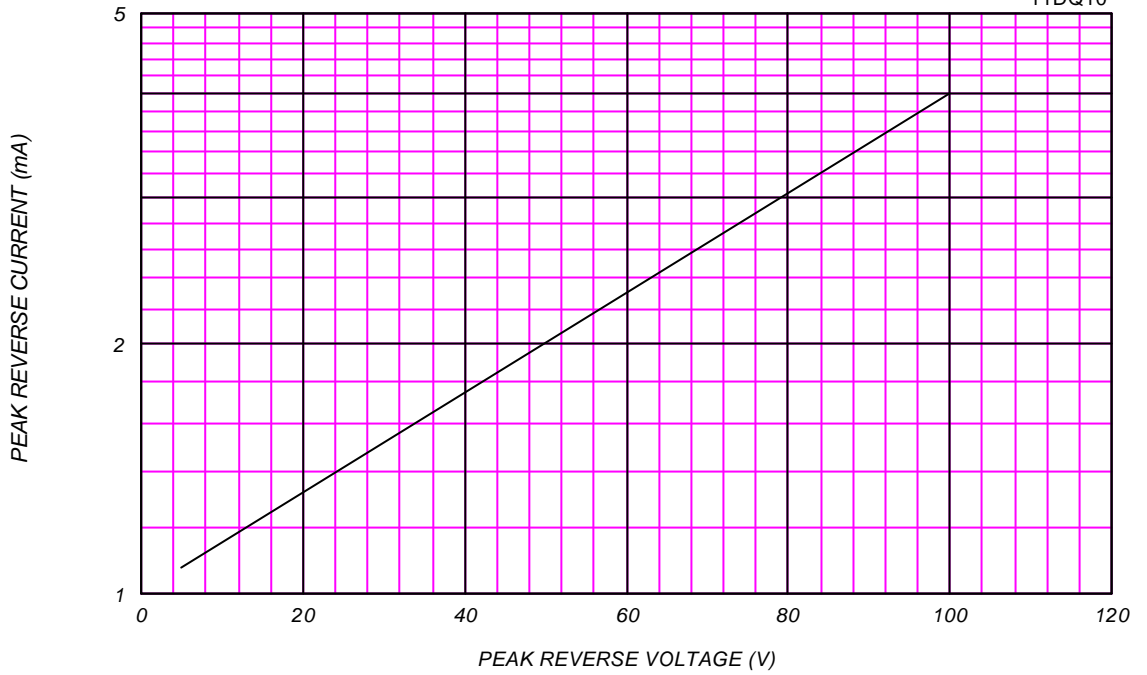

AVERAGE REVERSE POWER DISSIPATION

11DQ10

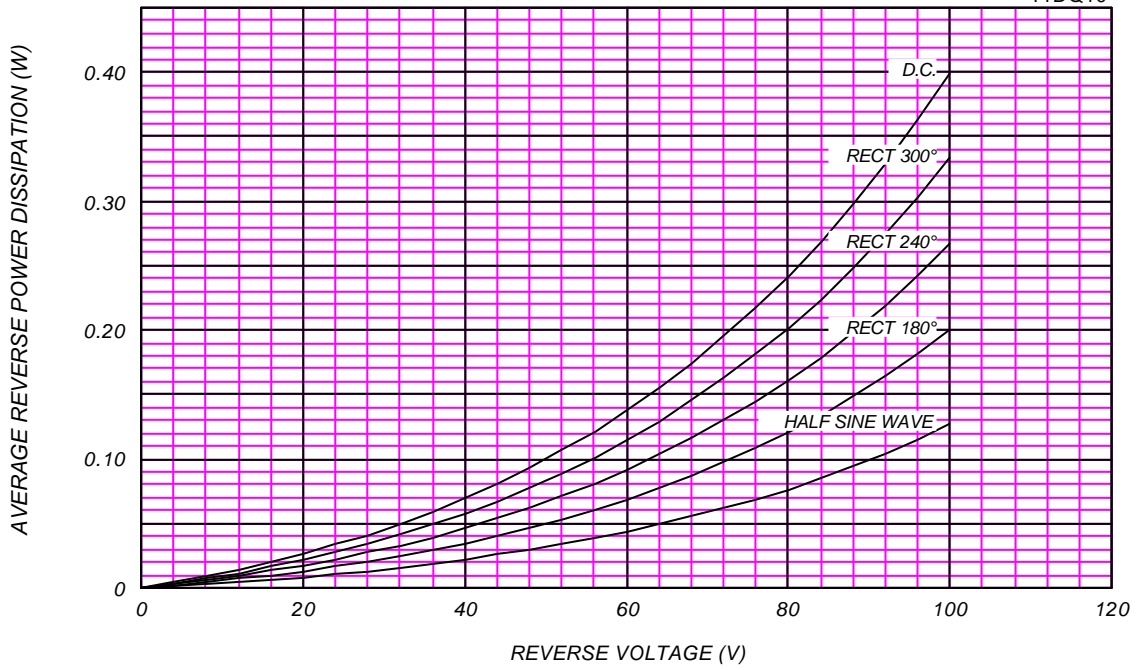

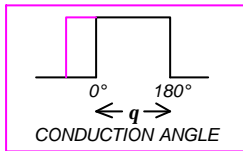

### AVERAGE FORWARD CURRENT VS. AMBIENT TEMPERATURE

Without Fin or P.C. Board,  $V_{RM}=100V$

11DQ10

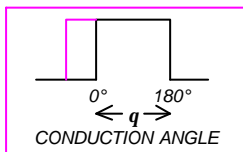
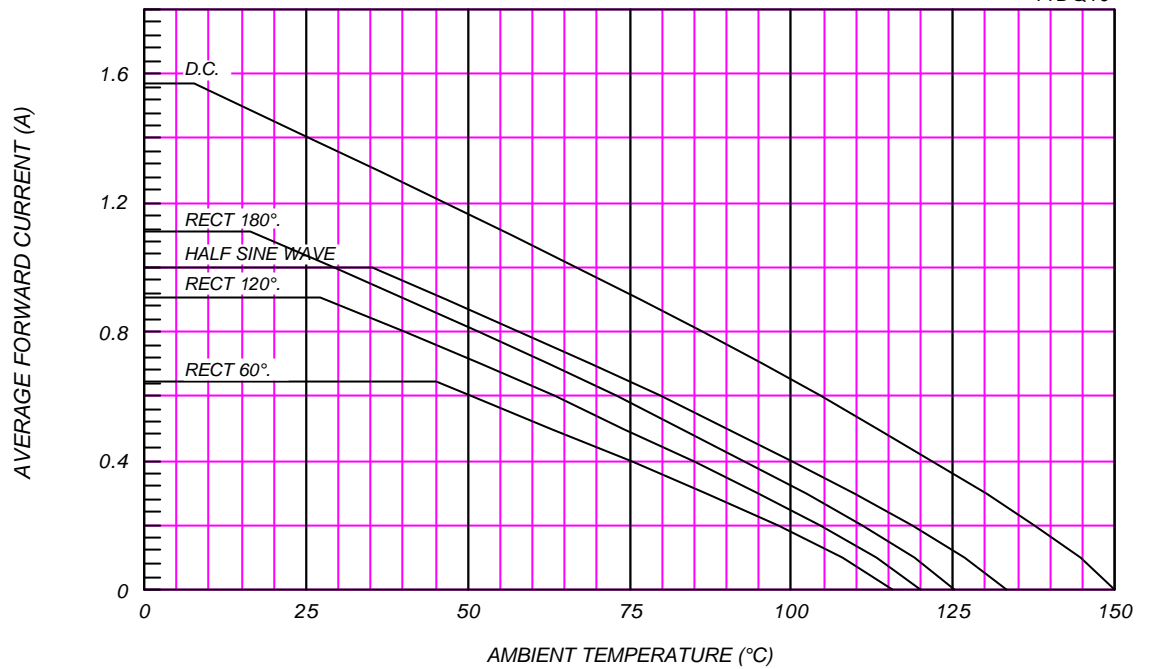

### AVERAGE FORWARD CURRENT VS. AMBIENT TEMPERATURE

P.C. Board mounted ( $L=8mm$ , Print Land= $10 \times 10mm$ ),  $V_{RM}=100V$

11DQ10

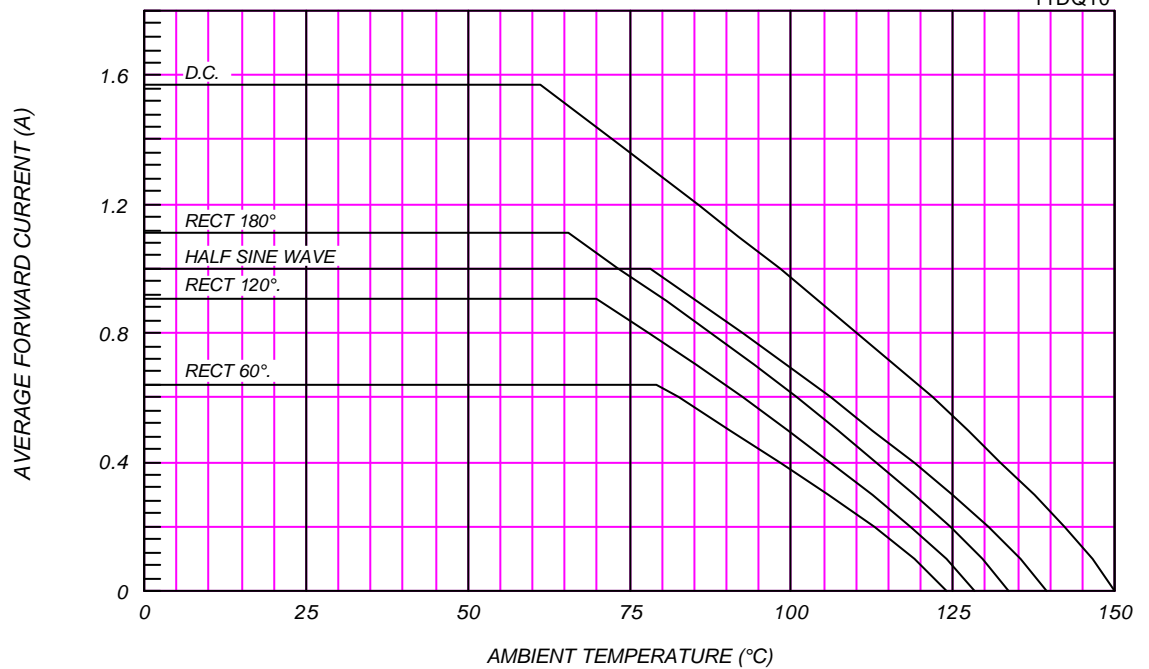

### SURGE CURRENT RATINGS

f=50Hz,Half Sine Wave,Non-Repetitive,No Load

11DQ10

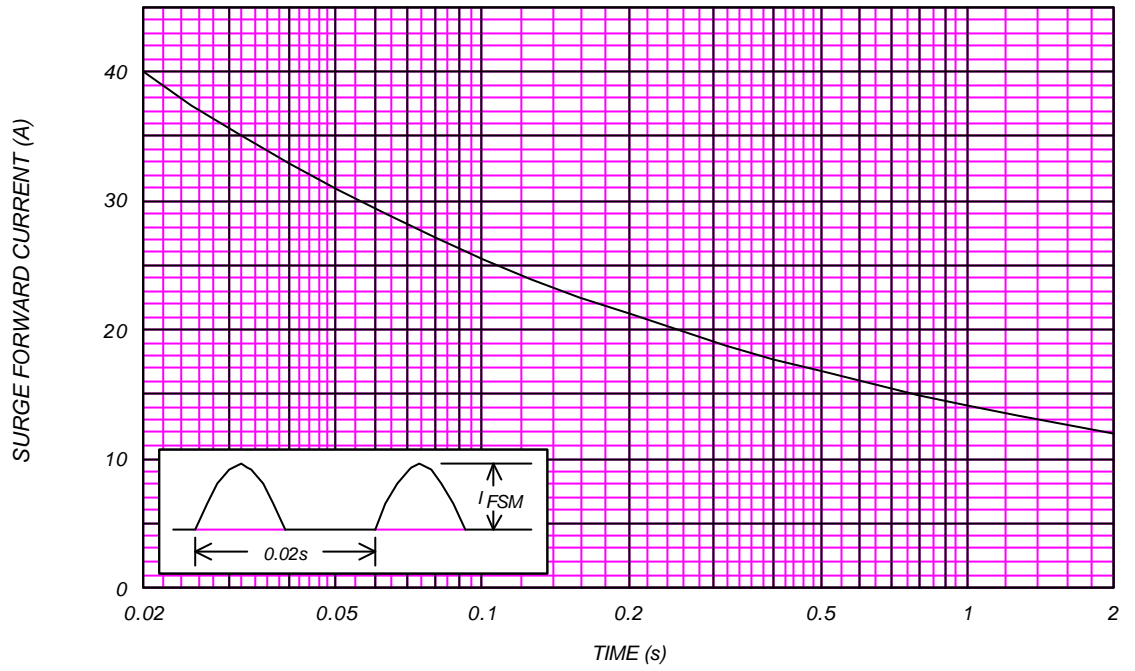

### JUNCTION CAPACITANCE VS. REVERSE VOLTAGE

$T_j = 25^\circ\text{C}$ ,  $V_m = 20\text{mV}_{\text{RMS}}$ ,  $f = 100\text{kHz}$ , Typical Value

11DQ10

