

16-BIT, 800 MSPS 2x–8x INTERPOLATING DUAL-CHANNEL DIGITAL-TO-ANALOG CONVERTER (DAC)

FEATURES

- Dual, 16-Bit, 800 MSPS DACs
- Dual, 16-Bit, 250 MSPS CMOS Input Data
 - 16 Sample Input FIFO
 - Flexible Input Data Bus Options
- High Performance
 - 81 dBc ACLR WCDMA TM1 at 70 MHz
- Selectable 2x–8x Interpolation Filters
 - Stop-band Attenuation > 80 dB
- Complex Mixer with 32-Bit NCO
- Digital Quadrature Modulator Correction
 - Gain, Phase and Offset Correction
- Digital Inverse SINC Filter
- 3- or 4-Wire Serial Control Interface
- On Chip 1.2-V Reference
- Differential Scalable Output: 2 to 20 mA
- Package: 64-pin 9x9mm QFN

APPLICATIONS

- Cellular Base Stations
- Broadband Wireless Access (BWA)
- WiMAX 802.16
- Fixed Wireless Backhaul
- Cable Modem Termination System (CMTS)

DESCRIPTION

The DAC5689 is a dual-channel 16-bit 800 MSPS digital-to-analog converter (DAC) with dual CMOS digital data bus, integrated 2x-8x interpolation filters, a fine frequency mixer with 32-bit complex numerically controlled oscillator (NCO), IQ compensation, and internal voltage reference. Different modes of operation enable or bypass various signal processing blocks. The DAC5689 offers superior linearity, noise and crosstalk performance.

The DAC5689 dual CMOS data bus provides 250 MSPS input data transfer per DAC channel. Several input data options are available: dual-bus data, single-bus interleaved data, even and odd multiplexing at half-rate, and an input FIFO with either external or internal clock to ease interface timing. Input data can be interpolated 2x, 4x or 8x by on-board digital interpolating FIR filters with over 80 dB of stop-band attenuation.

The DAC5689 allows both complex or real output. An optional 32-bit NCO/mixer in complex mode provides frequency upconversion and the dual DAC output produces a complex Hilbert Transform pair. A digital Inverse SINC filter compensates for the natural DAC $\sin(x)/x$ frequency roll-off. The digital Quadrature Modulator Correction (QMC) feature allows IQ compensation of phase, gain and offset to maximize sideband rejection and minimize LO feed-through of an external quadrature modulator performing the final single sideband RF up-conversion.

The DAC5689 is pin upgradeable to the DAC5688 which includes a clock multiplying PLL. The DAC5689 is characterized for operation over the industrial temperature range of -40°C to 85°C and is available in a 64-pin 9x9mm QFN package.

ORDERING INFORMATION⁽¹⁾⁽²⁾

ORDER CODE $T_A = -40^\circ\text{C to } 85^\circ\text{C}$	PACKAGE QTY TAPE AND REEL FORMAT	PACKAGE DRAWING/TYPE ^{(3) (4)}
DAC5689IRGCT	250	RGC / 64QFN Quad FlatpackNo-Lead
DAC5689IRGCR	2000	

(1) For correct DAC5689 operation, bits [1:0] in register CONFIG26 need to be set to "10" at device startup (see Recommended Startup Sequence).

(2) For the most current package and ordering information, see the Package Option Addendum at the end of this document, or see the TI website at www.ti.com.

(3) Thermal Pad Size: 7,4 mm × 7,4 mm

(4) MSL Peak Temperature: Level-3-260C-168 HR



Please be aware that an important notice concerning availability, standard warranty, and use in critical applications of Texas Instruments semiconductor products and disclaimers thereto appears at the end of this data sheet.



These devices have limited built-in ESD protection. The leads should be shorted together or the device placed in conductive foam during storage or handling to prevent electrostatic damage to the MOS gates.

FUNCTIONAL BLOCK DIAGRAM

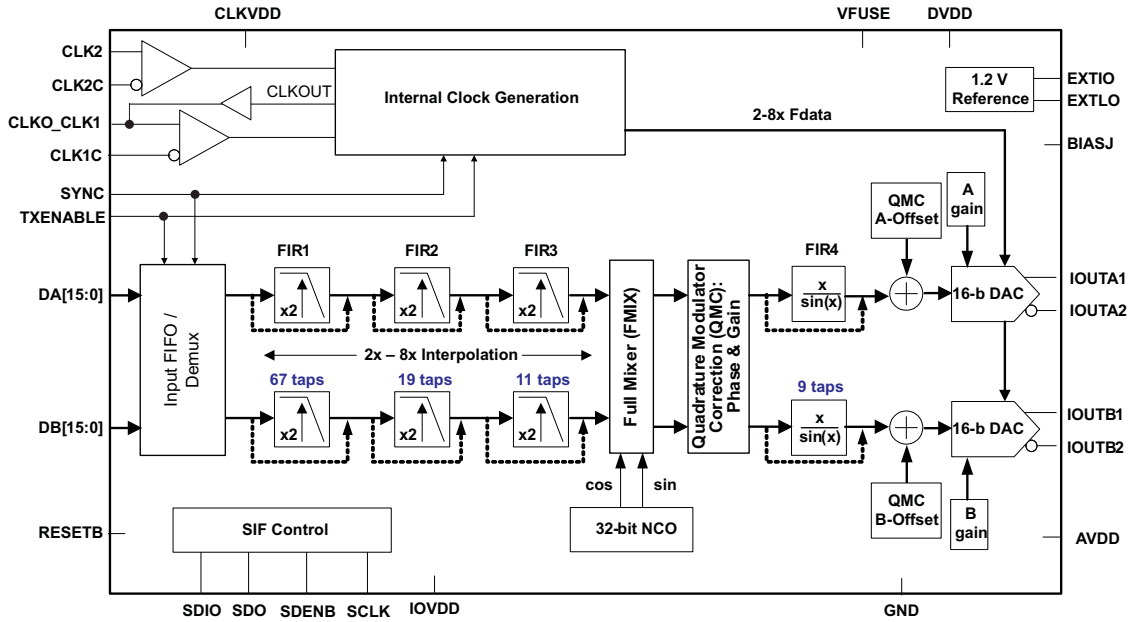

PINOUT

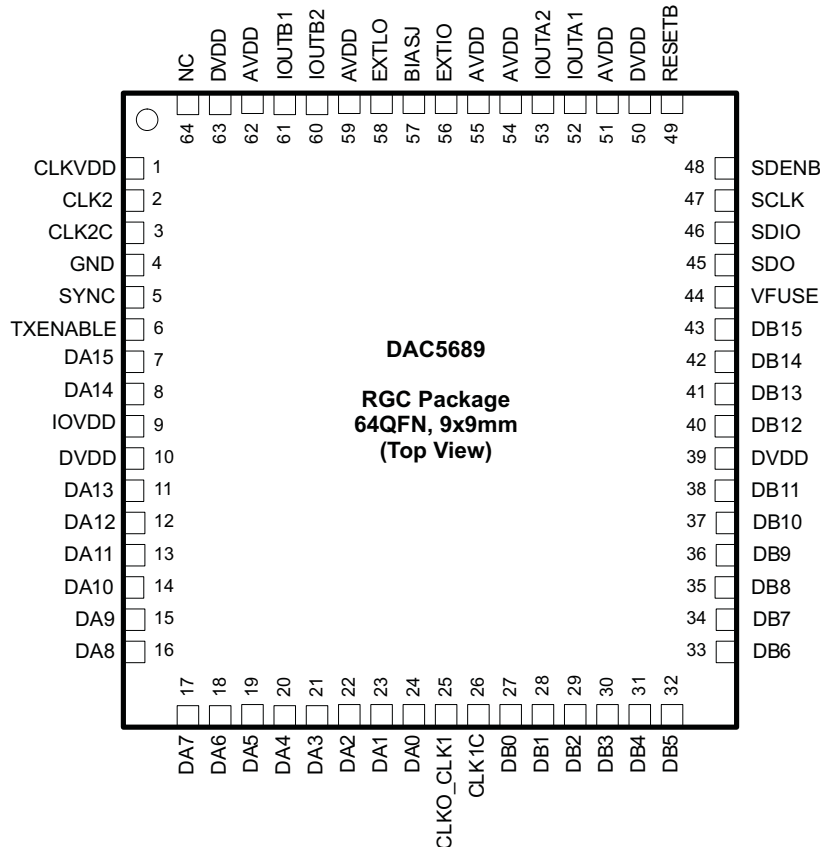

TERMINAL FUNCTIONS

TERMINAL		I/O	DESCRIPTION
NAME	NO.		
AVDD	51, 54, 55, 59, 62	I	Analog supply voltage. (3.3V)
BIASJ	57	O	Full-scale output current bias. For 20mA full-scale output current, connect a 960 Ω resistor to GND.
CLK2	2	I	Positive DAC clock input. Accepts frequencies up to 800MHz.
CLK2C	3	I	Complementary CLK2 input.
CLKO_CLK1	25	I/O	In Dual Clock Mode can be used to provide the lower frequency input clock. The lower frequency clock can be differential or single-ended. If single-ended CLK1 can be used as the clock input. CLK1C must be AC coupled to GND in this case. Optionally provides (CLKO) output for data bus source. Internal pull-down.
CLK1C	26	I/O	In Dual Clock Mode can be used to provide the lower frequency input clock. The lower frequency clock can be differential or single-ended. If differential, CLK1C is the complementary clock input. If single-ended it can be used as the clock input. CLKO_CLK1 must be AC coupled to GND in this case. Internal pull-down.
CLKVDD	1	I	Internal clock buffer supply voltage. (1.8V) It is recommended to isolate this supply from DVDD.
DA[15..0]	7, 8, 11–24	I	A-Channel Data Bits 0 through 15. DA15 is most significant data bit (MSB) – pin 7 DA0 is least significant data bit (LSB) – pin 24 Internal pull-down. The order of bus can be reversed via CONFIG4 reva bit.
DB[15..0]	40–43, 27–38	I	B-Channel Data Bits 0 through 15. DB15 is most significant data bit (MSB) – pin 43 DB0 is least significant data bit (LSB) – pin 27 Internal pull-down. The order of bus can be reversed via CONFIG4 revb bit.
DVDD	10, 39, 50, 63	I	Digital supply voltage. (1.8V) For best performance it is recommended to isolate pins 10 and 39 from all other 1.8V supplies.
EXTIO	56	I/O	Used as external reference input when internal reference is disabled (i.e., EXTLO connected to AVDD). Used as internal reference output when EXTLO = GND, requires a 0.1μF decoupling capacitor to GND when used as reference output
EXTLO	58	O	Connect to GND for internal reference, or AVDD for external reference.
GND	4, Thermal Pad	I	Pin 4 and the Thermal Pad located on the bottom of the QFN package is ground for AVDD, DVDD and IOVDD supplies.
IOUTA1	52	O	A-Channel DAC current output. An offset binary data pattern of 0x0000 at the DAC input results in a full scale current sink and the least positive voltage on the IOUTA1 pin. Similarly, a 0xFFFF data input results in a 0 mA current sink and the most positive voltage on the IOUTA1 pin. In single DAC mode, outputs appear on the IOUTA1/A2 pair only.
IOUTA2	53	O	A-Channel DAC complementary current output. The IOUTA2 has the opposite behavior of the IOUTA1 described above. An input data value of 0x0000 results in a 0mA sink and the most positive voltage on the IOUTA2 pin.
IOUTB1	61	O	B-Channel DAC current output. Refer to IOUTA1 description above.
IOUTB2	60	O	B-Channel DAC complementary current output. Refer to IOUTA2 description above.
IOVDD	9	I	3.3V supply voltage for all digital I/O. Note: This supply input should remain at 3.3V regardless of the 1.8V or 3.3V selectable digital input switching thresholds via CONFIG26 io_1p8_3p3 .
NC	64	I	No connect. Leave open for proper operation.
SYNC	5	I	Optional SYNC input for internal clock dividers, FIFO, NCO and QMC blocks. Internal pull-down.
RESETB	49	I	Resets the chip when low. Internal pull-up.
SCLK	47	I	Serial interface clock. Internal pull-down.
SDENB	48	I	Active low serial data enable, always an input to the DAC5689. Internal pull-up.
SDIO	46	I/O	Bi-directional serial data in 3-pin mode (default). In 4-pin interface mode (CONFIG5 sif4), the SDIO pin is an input only. Internal pull-down.
SDO	45	O	Uni-directional serial interface data in 4-pin mode (CONFIG5 sif4). The SDO pin is 3-stated in 3-pin interface mode (default). Internal pull-down.

TERMINAL FUNCTIONS (continued)

TERMINAL		I/O	DESCRIPTION
NAME	NO.		
TXENABLE	6	I	Transmit enable input. Internal pull-down. TXENABLE must be high for the DATA to the DAC to be enabled. When TXENABLE is low, the digital logic section is forced to all 0, and any input data is ignored.
VFUSE	44	I	Digital supply voltage. (1.8V) This supply pin is also used for factory fuse programming. Connect to DVDD pins for normal operation.

ABSOLUTE MAXIMUM RATINGSover operating free-air temperature range (unless otherwise noted)⁽¹⁾

		VALUE	UNIT
Supply voltage range	DVDD ⁽²⁾	–0.5 to 2.3	V
	VFUSE ⁽²⁾	–0.5 to 2.3	V
	CLKVDD ⁽²⁾	–0.5 to 2.3	V
	AVDD ⁽²⁾	–0.5 to 4	V
	IOVDD ⁽²⁾	–0.5 to 4	V
Supply voltage range	AVDD to DVDD	–2 to 2.6	V
	CLKVDD to DVDD	–0.5 to 0.5	V
	IOVDD to AVDD	–0.5 to 0.5	V
	CLK2, CLK2C ⁽²⁾	–0.5 to CLKVDD + 0.5	V
	CLKO_CLK1, CLK1C, SLEEP, TXENABLE ⁽²⁾	–0.5 to IOVDD + 0.5	V
	DA[15..0], DB[15..0] ⁽²⁾	–0.5 to IOVDD + 0.5	V
	SDO, SDIO, SCLK, SDENB, RESETB ⁽²⁾	–0.5 to IOVDD + 0.5	V
	IOUTA1/B1, IOUTA2/B2 ⁽²⁾	–0.5 to AVDD + 0.5	V
EXTIO, EXTLO, BIASJ ⁽²⁾	–0.5 to AVDD + 0.5	V	
Peak input current (any input)		20 mA	mA
Peak total input current (all inputs)		–30 mA	mA
Operating free-air temperature range, T _A : DAC5689I		–40 to 85	°C
Storage temperature range		–65 to 150	°C

(1) Stresses beyond those listed under *absolute maximum ratings* may cause permanent damage to the device. These are stress ratings only, and functional operation of these or any other conditions beyond those indicated under *recommended operating conditions* is not implied. Exposure to absolute-maximum-rated conditions for extended periods may affect device reliability.

(2) Measured with respect to GND.

THERMAL CHARACTERISTICS

over operating free-air temperature range (unless otherwise noted)

THERMAL CONDUCTIVITY		64ld QFN	UNIT
T _J	Maximum junction temperature ⁽¹⁾⁽²⁾	125	°C
θ _{JA}	Theta junction-to-ambient (still air)	22	°C/W
	Theta junction-to-ambient (150 lfm)	15	
ψ _{JT}	Psi junction-to-top of package	0.2	°C/W
θ _{JB}	Theta junction-to-board	3.5	°C/W

(1) Air flow or heat sinking reduces θ_{JA} and may be required for sustained operation at 85°C under maximum operating conditions.

(2) It is strongly recommended to solder the device thermal pad to the board ground plane.

ELECTRICAL CHARACTERISTICS (DC Specifications)

over recommended operating free-air temperature range, AVDD, IOVDD = 3.3 V, DVDD, CLKVDD = 1.8 V, Iout_{FS} = 20 mA

PARAMETER		TEST CONDITIONS	MIN	TYP	MAX	UNIT		
RESOLUTION			16			Bits		
DC ACCURACY								
INL	Integral nonlinearity	1 LSB = IOUT _{FS} /2 ¹⁶		±4		LSB		
DNL	Differential nonlinearity			±2		LSB		
ANALOG OUTPUT								
Coarse gain linearity				± 0.04		LSB		
Offset error mid code offset				0.01		%FSR		
Gain error		With external reference		1		%FSR		
		With internal reference		0.7		%FSR		
Gain mismatch		With internal reference, dual DAC mode	-2		2	%FSR		
Minimum full scale output current		Nominal full-scale current, IOUT _{FS} = 16 × IBIAS current.		2		mA		
Maximum full scale output current				20				
Output compliance range ⁽¹⁾		IOUT _{FS} = 20 mA	AVDD - 0.5V		AVDD + 0.5V	V		
Output resistance				300		kΩ		
Output capacitance				5		pF		
REFERENCE OUTPUT								
V _{REF}	Reference output voltage	Internal Reference Mode	1.14	1.2	1.26	V		
	Reference output current ⁽²⁾			100			nA	
REFERENCE INPUT								
V _{EXTIO}	Input voltage range	External Reference Mode	0.1		1.25	V		
	Input resistance				1		MΩ	
Small signal bandwidth		CONFIG26: isbiaslpf_a and isbiaslpf_b = 0		95		kHz		
		CONFIG26: isbiaslpf_a and isbiaslpf_b = 1		472				
Input capacitance				100		pF		
TEMPERATURE COEFFICIENTS								
Offset drift				±1		ppm of FSR/°C		
Gain drift		With external reference		±15				
		With internal reference		±30				
Reference voltage drift				±8		ppm/°C		
POWER SUPPLY								
AVDD, IOVDD			3.0	3.3	3.6	V		
DVDD, CLKVDD			1.7	1.8	1.9	V		
PSRR	Power supply rejection ratio	DC tested	-0.2		0.2	%FSR/V		
P	AVDD + IOVDD current, 3.3V	Mode 1: x8 Interp, QMC = off, ISINC = off, DAC A+B on, F _{IN} = 5 MHz Tone, NCO = 145 MHz, F _{OUT} = 150 MHz, F _{DAC} = 500 MHz		140		mA		
	DVDD + CLKVDD current, 1.8V			430		mA		
	Power Dissipation			1240		mW		
	AVDD + IOVDD current, 3.3V		Mode 2: x8 Interp, QMC = on, ISINC = on, DAC A+B on, F _{IN} = 5 MHz Tone, NCO = 91 MHz, F _{OUT} = 96 MHz, F _{DAC} = 614.4 MHz		140		mA	
	DVDD + CLKVDD current, 1.8V				520		mA	
	Power dissipation				1400		mW	
	AVDD + IOVDD current, 3.3V			Mode 3 (Max): x4 Interp, QMC = on, ISINC = on, DAC A+B on, F _{IN} = 5 MHz Tone, NCO = 135 MHz, F _{OUT} = 140 MHz, F _{DAC} = 800 MHz		140		mA
	DVDD + CLKVDD current, 1.8V					680		mA
	Power dissipation					1690	1950	mW
	AVDD + IOVDD current, 3.3V				Mode 4 (Sleep): x8 Interp, QMC = off, ISINC = off, DAC A+B off, F _{IN} = 5 MHz Tone, NCO = off, F _{OUT} = off, F _{DAC} = 800 MHz,		12	
DVDD + CLKVDD current, 1.8V		15					mA	
Power dissipation		65				100	mW	

(1) The upper limit of the output compliance is determined by the CMOS process. Exceeding this limit may result in transistor breakdown, resulting in reduced reliability of the DAC5689 device. The lower limit of the output compliance is determined by the load resistors and full-scale output current. Exceeding the upper limit adversely affects distortion performance and integral nonlinearity.

(2) Use an external buffer amplifier with high impedance input to drive any external load.

ELECTRICAL CHARACTERISTICS (AC Specifications)

Over recommended operating free-air temperature range, AVDD, IOVDD = 3.3 V, DVDD, CLKVDD = 1.8 V, IOUT_{FS} = 20 mA

PARAMETER		TEST CONDITIONS	MIN	TYP	MAX	UNIT
ANALOG OUTPUT⁽¹⁾						
f _{DAC}	Maximum output update rate		800			MSPS
t _{s(DAC)}	Output settling time to 0.1%	Transition: Code 0x0000 to 0xFFFF		10.4		ns
t _{pd}	Output propagation delay	DAC outputs are updated on falling edge of DAC clock. Does not include Digital Latency (see below).		2		ns
t _{r(IOUT)}	Output rise time	10% to 90%		220		ps
t _{f(IOUT)}	Output fall time	90% to 10%		220		ps
Digital latency		No Interp, NCO off, QMC off, ISINC = off		109		DAC clock cycles
		x2 Interpolation, NCO off, QMC off, ISINC = off		172		
		x4 Interpolation, NCO off, QMC off, ISINC = off		276		
		x8 Interpolation, NCO off, QMC off, ISINC = off		488		
		x8 Interpolation, NCO on, QMC off, ISINC = off		512		
		x8 Interpolation, NCO on, QMC on, ISINC = off		528		
		x8 Interpolation, NCO on, QMC on, ISINC = on		548		
AC PERFORMANCE⁽²⁾						
SFDR	Spurious free dynamic range	x4 Interp, CLK2 = 800 MHz, DAC A+B on, 0 dBFS Single tone, F _{OUT} = F _{IN} First Nyquist Zone < f _{DATA} /2	F _{OUT} = 10.1 MHz	83		dBc
			F _{OUT} = 20.1 MHz	79		
SNR	Signal-to-noise ratio	x4 Interp, CLK2 = 800 MHz, DAC A+B on, 0 dBFS Single tone, F _{IN} = 10.1 MHz, F _{OUT} = F _{IN} + NCO	NCO= 10 MHz, F _{OUT} = 20.1 MHz	72		dBc
			NCO= 60 MHz, F _{OUT} = 70.1 MHz	68		
			NCO= 140 MHz, F _{OUT} = 150.1 MHz	64		
			NCO= 290 MHz, F _{OUT} = 300.1 MHz	57		
IMD3	Third-order Two-Tone intermodulation (Each tone at -6 dBFS)	x4 Interp, CLK2 = 800 MHz, DAC A+B on, F _{IN} = 10.5 and 11.5 MHz, F _{OUT} = F _{IN} + NCO	NCO= 40 MHz, F _{OUT} = 51±0.5 MHz	85		dBc
			NCO= 60 MHz, F _{OUT} = 71±0.5 MHz	83		
			NCO= 130 MHz, F _{OUT} = 141±0.5 MHz	74		
IMD	Four-tone Intermodulation to Nyquist (Each tone at -12 dBFS)	x4 Interp, CLK2 = 800 MHz, DAC A+B on, F _{IN} = 9.8, 10.4, 11.6 and 12.2 MHz (600kHz spacing), NCO = 129 MHz, F _{OUT} = F _{IN} + NCO = 140±1.2 MHz		73		dBc
ACLR ⁽³⁾	Adjacent channel leakage ratio	x8 Interp, CLK2 = 737.28 MHz, DAC A+B on, F _{IN} = 23.04 MHz, NCO = off	Single Carrier, F _{OUT} = 23.04 MHz	81		dBc
			Single Carrier, F _{OUT} = 70MHz	81		
			Single Carrier, F _{OUT} = 140MHz	78		
			Four Carrier, F _{OUT} = 140MHz	70		
Noise floor, noise spectral density (NSD) ⁽³⁾		x8 Interp, CLK2 = 737.28 MHz, DAC A+B on, F _{IN} = F _{OUT} = Baseband I/Q, 50 MHz offset, 1 MHz BW	Single Carrier Noise Floor	101		dBm
			Single Carrier NSD in 1 MHz BW	161		dBm/Hz
			Four Carrier Noise Floor	101		dBm
			Four Carrier NSD in 1 MHz BW	161		dBm/Hz

- (1) Measured differential across IOUTA1 and IOUTA2 or IOUTB1 and IOUTB2 with 25 Ω each to AVDD.
- (2) 4:1 transformer output termination, 50Ω doubly terminated load
- (3) W-CDMA with 3.84 MHz BW, 5-MHz spacing, centered at IF. TESTMODEL 1, 10 ms

ELECTRICAL CHARACTERISTICS (Digital Specifications)

Over recommended operating free-air temperature range, AVDD, IOVDD = 3.3V, DVDD, CLKVDD = 1.8V, Iout_{FS} = 20 mA

PARAMETER		TEST CONDITIONS	MIN	TYP	MAX	UNIT
CMOS INTERFACE: SDO, SDIO, SCLK, SDENB, RESETB, DA[15:0], DB[15:0], SYNC, TXENABLE, CLKO_CLK1						
V _{IH}	High-level input voltage	CONFIG26 io_1p8_3p3 = 0 (3.3V levels)	2.30			V
		CONFIG26 io_1p8_3p3 = 1 (1.8V levels)	1.25			
V _{IL}	Low-level input voltage	CONFIG26 io_1p8_3p3 = 0 (3.3V levels)			1.00	V
		CONFIG26 io_1p8_3p3 = 1 (1.8V levels)			0.54	
I _{IH}	High-level input current			±20		μA
I _{IL}	Low-level input current			±20		μA
C _I	CMOS Input capacitance			2		pF
V _{OH}	SDO, SDIO, CLKO	I _{LOAD} = -100 μA	IOVDD - 0.2			V
	SDO, SDIO, CLKO	I _{LOAD} = -2 mA	0.8 × IOVDD			
V _{OL}	SDO, SDIO, CLKO	I _{LOAD} = 100 μA			0.2	V
	SDO, SDIO, CLKO	I _{LOAD} = 2 mA			0.5	
	Input data rate		0		250	MSPS
t _{s(SDENB)}	Setup time, SDENB to rising edge of SCLK		20			ns
t _{s(SDIO)}	Setup time, SDIO valid to rising edge of SCLK		10			ns
t _{h(SDIO)}	Hold time, SDIO valid to rising edge of SCLK		5			ns
t _{SCLK}	Period of SCLK		100			ns
t _{SCLKH}	High time of SCLK		40			ns
t _{SCLKL}	Low time of SCLK		40			ns
t _{d(Data)}	Data output delay after falling edge of SCLK			10		ns
t _{RESET}	Minimum RESETB pulse width			25		ns
TIMING PARALLEL DATA INPUT TO CLK1/C (DUAL CLOCK and DUAL SYNCHRONOUS CLOCK MODES: Figure 28)						
t _s	Setup time	CLK1/C = input	1			ns
t _h	Hold time		1			ns
t _{align}	Max timing offset between CLK1 and CLK2 rising edges	DUAL SYNCHRONOUS BUS MODE only (Typical characteristic)	$\frac{1}{2f_{CLK2}} - 0.55$			ns
TIMING PARALLEL DATA INPUT TO CLKO (EXTERNAL CLOCK MODE: Figure 29)						
t _s	Setup time	CLKO_CLK1 = output. Note: Delay time increases with higher capacitive loads.	1			ns
t _h	Hold time		1			ns
t _{d(CLKO)}	Delay time			4.5		ns
CLOCK INPUT (CLK2/CLK2C)						
	CLK2/C Duty cycle		40%		60%	
	CLK2/C Differential voltage ⁽¹⁾		0.4	1		V
	CLK2/C Input common mode		2/3 × CLKVDD			V
	CLK2C Input Frequency				800	MHz
CLOCK INPUT (CLK1/CLK1C)						
	CLK1/C Duty cycle		40%		60%	
	CLK1/C Differential voltage		0.4	1.0		V
	CLK1/C Input common mode		IOVDD / 2			V
	CLK1/C Input Frequency				250	MHz
CLOCK OUTPUT (CLKO)						
	CLKO Output frequency ⁽²⁾	with 10pF load			185	MHz

(1) Driving the clock input with a differential voltage lower than 1V will result in degraded performance.

(2) Specified by design and simulation. Not production tested. It is recommended to buffer CLKO.

TYPICAL CHARACTERISTICS

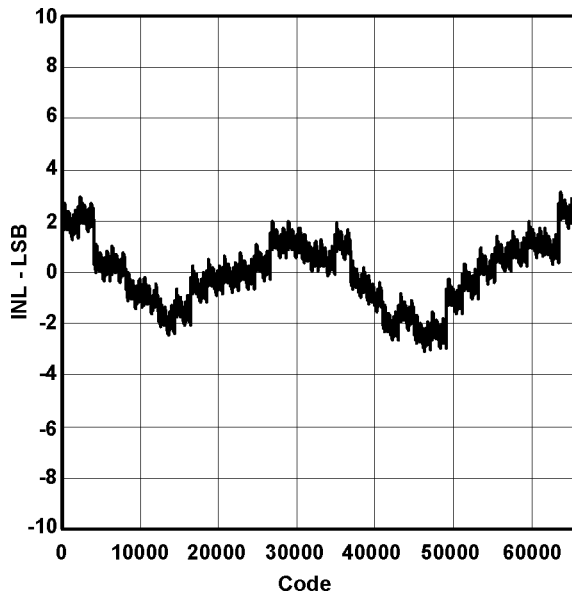

Figure 1. Integral Nonlinearity

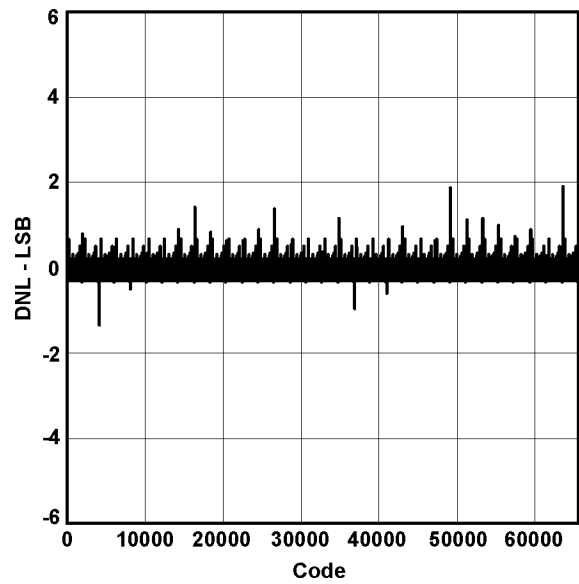

Figure 2. Differential Nonlinearity

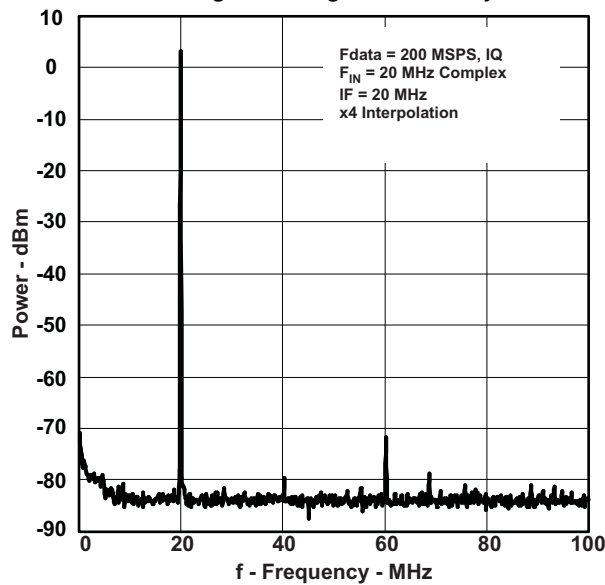

Figure 3. Single Tone Spectral Plot

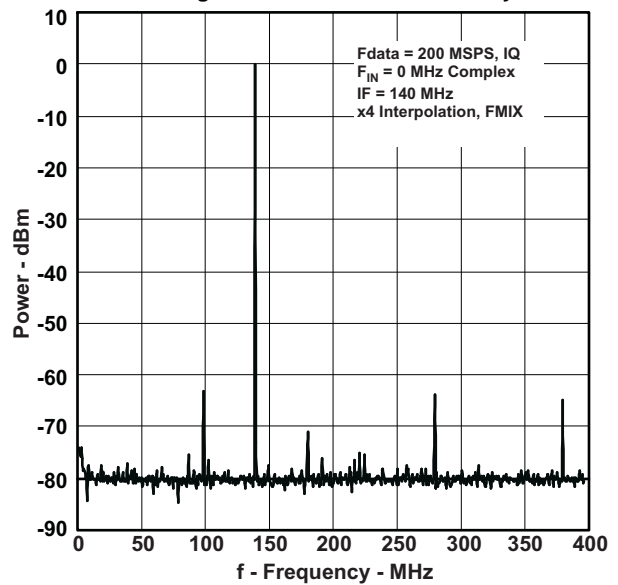

Figure 4. Single Tone Spectral Plot

TYPICAL CHARACTERISTICS (continued)

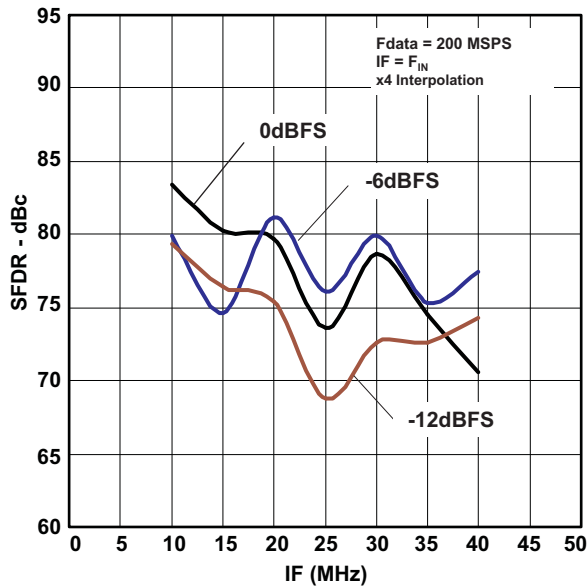

Figure 5. In-Band SFDR vs. Intermediate Frequency

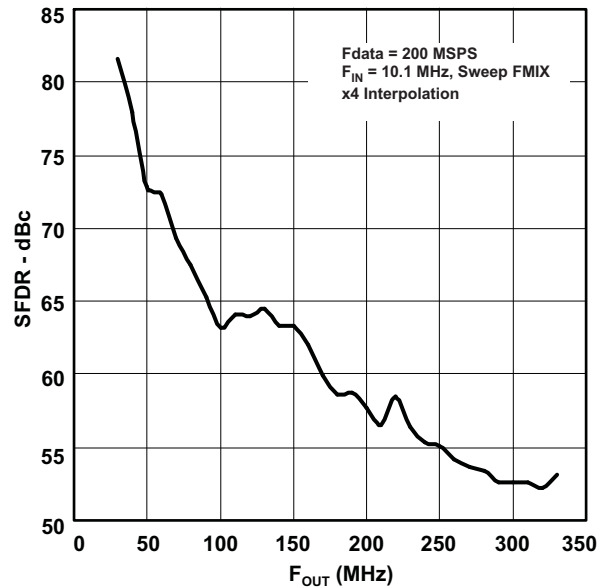

Figure 6. Out-Of-Band SFDR vs Intermediate Frequency

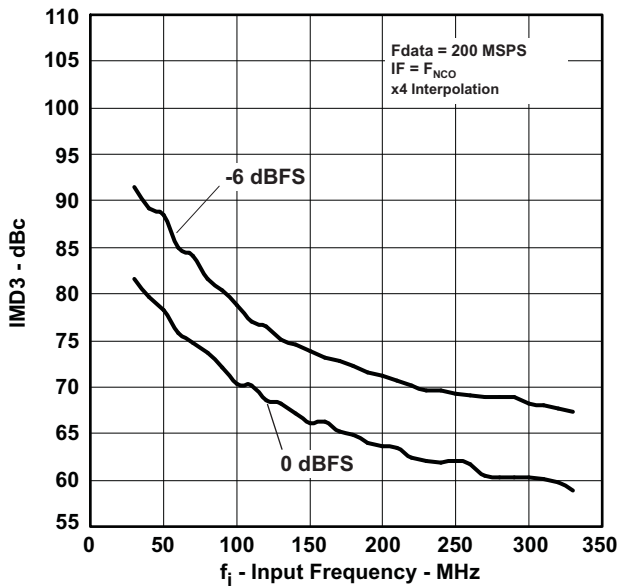

Figure 7. Two Tone IMD vs Intermediate Frequency

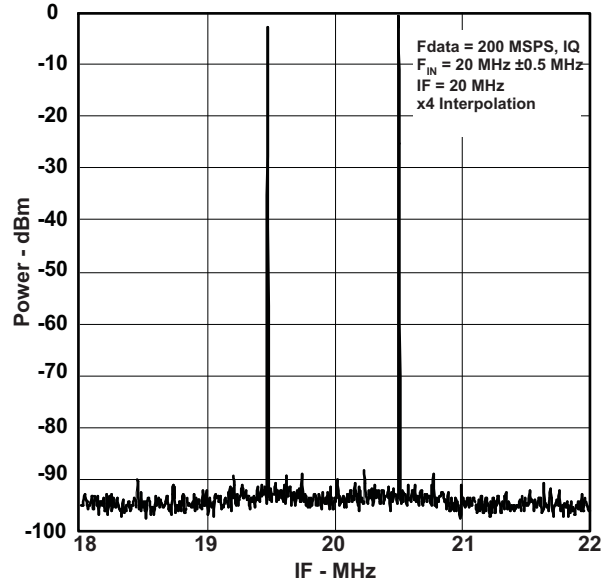

Figure 8. Two Tone IMD Spectral Plot

TYPICAL CHARACTERISTICS (continued)

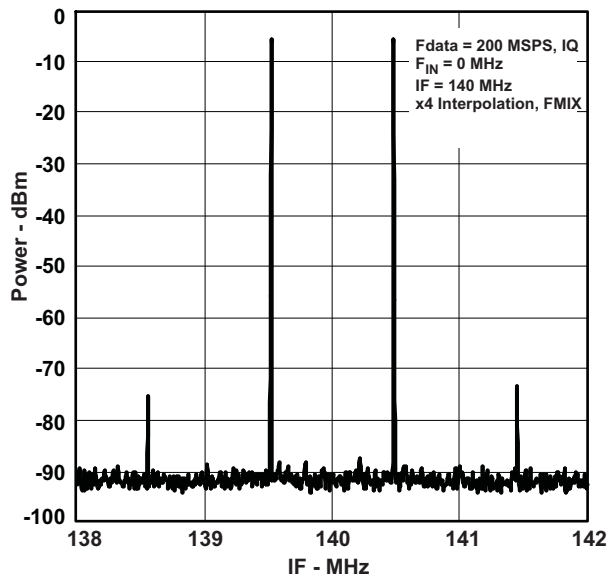

Figure 9. Two Tone IMD Spectral Plot

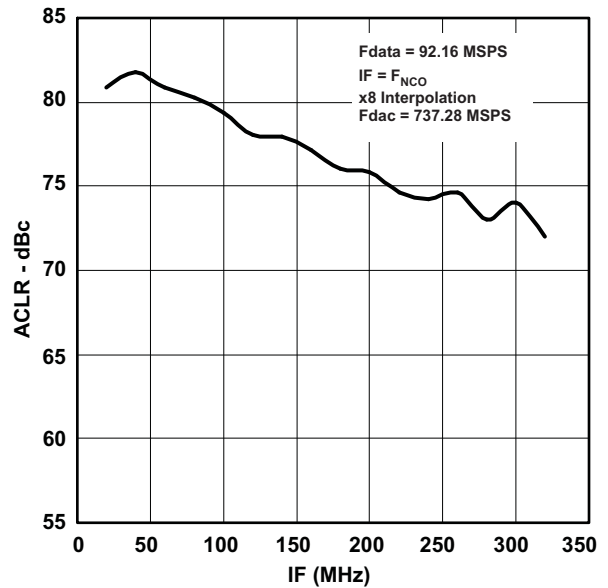

Figure 10. WCDMA ACLR vs Intermediate Frequency

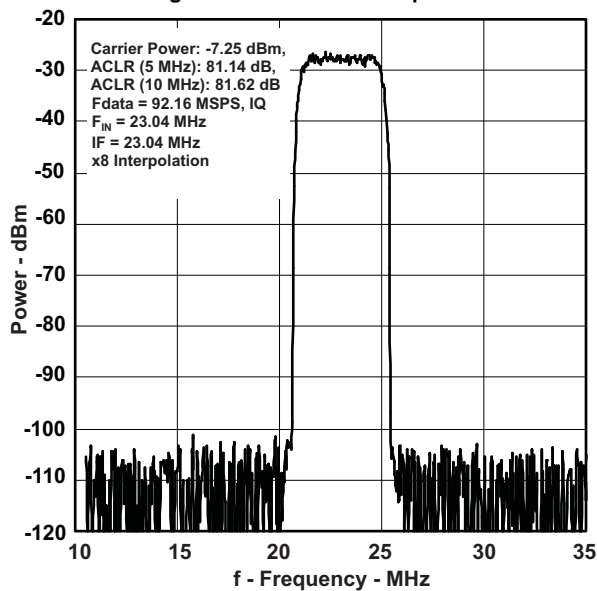

Figure 11. WCDMA TM1: Single Carrier

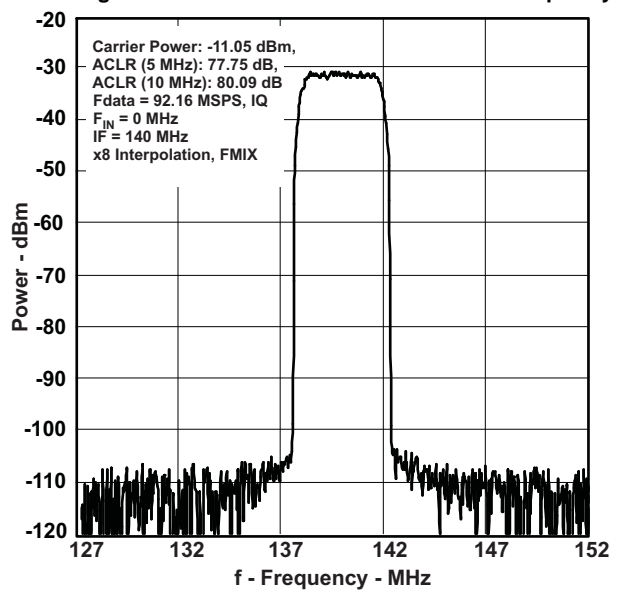

Figure 12. WCDMA TM1: Single Carrier

TYPICAL CHARACTERISTICS (continued)

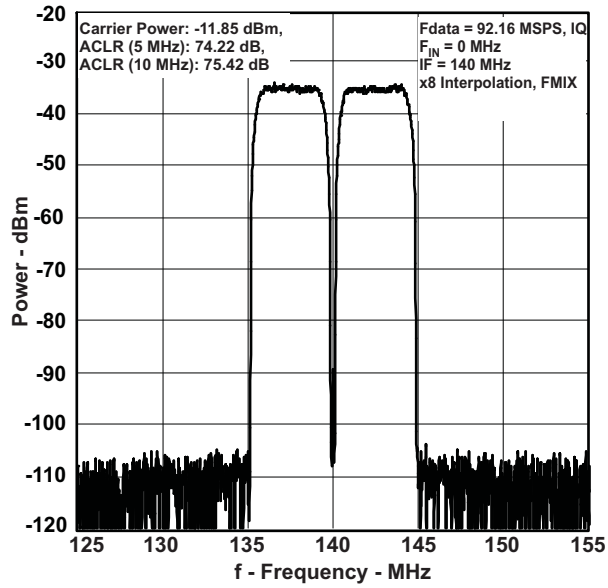

Figure 13. WCDMA TM1:Two Carriers

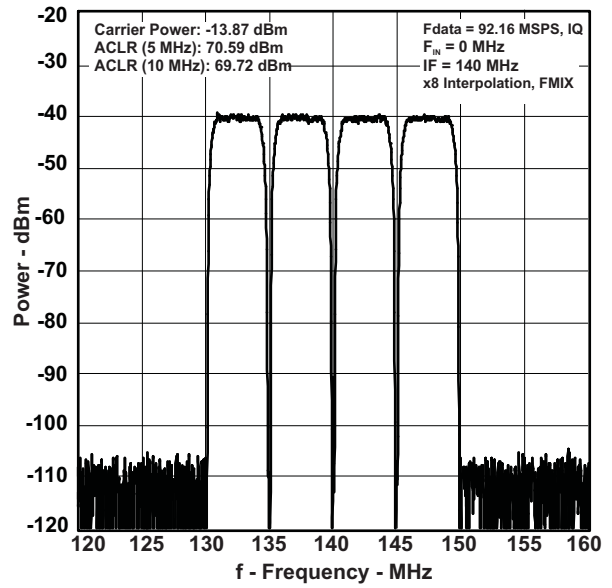

Figure 14. WCDMA TM1:Four Carriers

TEST METHODOLOGY

Typical AC specifications were characterized with the DAC5689EVM. A sinusoidal master clock frequency is generated by an HP8665B signal generator which drives an Agilent 8133A pulse generator to generate a square wave output clock for the TSW3100 Pattern Generator and EVM input clock. On the EVM, the input clock is driven by an CDCM7005 clock distribution chip that is configured to simply buffer the external clock or divide it down for necessary test configurations.

The DAC5689 output is characterized with a Rohde and Schwarz FSU spectrum analyzer. For WCDMA signal characterization, it is important to use a spectrum analyzer with high IP3 and noise subtraction capability so that the spectrum analyzer does not limit the ACPR measurement.

DEFINITION OF SPECIFICATIONS

Adjacent Carrier Leakage Ratio (ACLR): Defined for a 3.84Mcps 3GPP W-CDMA input signal measured in a 3.84MHz bandwidth at a 5MHz offset from the carrier with a 12dB peak-to-average ratio.

Analog and Digital Power Supply Rejection Ratio (APSR, DPSRR): Defined as the percentage error in the ratio of the delta IOUT and delta supply voltage normalized with respect to the ideal IOUT current.

Differential Nonlinearity (DNL): Defined as the variation in analog output associated with an ideal 1 LSB change in the digital input code.

Gain Drift: Defined as the maximum change in gain, in terms of ppm of full-scale range (FSR) per °C, from the value at ambient (25°C) to values over the full operating temperature range.

Gain Error: Defined as the percentage error (in FSR%) for the ratio between the measured full-scale output current and the ideal full-scale output current.

Integral Nonlinearity (INL): Defined as the maximum deviation of the actual analog output from the ideal output, determined by a straight line drawn from zero scale to full scale.

Intermodulation Distortion (IMD3, IMD): The two-tone IMD3 or four-tone IMD is defined as the ratio (in dBc) of the worst 3rd-order (or higher) intermodulation distortion product to either fundamental output tone.

Offset Drift: Defined as the maximum change in DC offset, in terms of ppm of full-scale range (FSR) per °C, from the value at ambient (25°C) to values over the full operating temperature range.

Offset Error: Defined as the percentage error (in FSR%) for the ratio of the differential output current (IOUT1–IOUT2) and the mid-scale output current.

Output Compliance Range: Defined as the minimum and maximum allowable voltage at the output of the current-output DAC. Exceeding this limit may result reduced reliability of the device or adversely affecting distortion performance.

Reference Voltage Drift: Defined as the maximum change of the reference voltage in ppm per degree Celsius from value at ambient (25°C) to values over the full operating temperature range.

Spurious Free Dynamic Range (SFDR): Defined as the difference (in dBc) between the peak amplitude of the output signal and the peak spurious signal.

Signal to Noise Ratio (SNR): Defined as the ratio of the RMS value of the fundamental output signal to the RMS sum of all other spectral components below the Nyquist frequency, including noise, but excluding the first six harmonics and dc.

REGISTER DESCRIPTIONS

REGISTER MAP

Table 1. Register Map

Name	Address	Default	Bit 7 (MSB)	Bit 6	Bit 5	Bit 4	Bit 3	Bit 2	Bit 1	Bit 0 (LSB)	
STATUS0	0x00	0x03	Reserved	Unused	Unused	device_ID(2:0)			version(1:0)		
CONFIG1	0x01	0x0B	inset_mode(1:0)		Unused	synchr_clkin	twos	inv_inclk	interp_value(1:0)		
CONFIG2	0x02	0xE1	dualclk_ena	clko_off	Reserved	clko_SE_hold	fir4_ena	qmc_offset_ena	qmc_corr_ena	mixer_ena	
CONFIG3	0x03	0x00	diffclk_dly(1:0)		clko_dly(1:0)		Reserved				
CONFIG4	0x04	0x00	ser_dac_data_ena	output_delay(1:0)		B_equals_A	A_equals_B	Unused	reva	revb	
CONFIG5	0x05	0x22	sif4	sif_sync_sig	clkdiv_sync_ena	clkdiv_sync_sel	Reserved	clkdiv_shift	mixer_gain	Unused	
CONFIG6	0x06	0x00	phaseoffset(7:0)								
CONFIG7	0x07	0x00	phaseoffset(15:8)								
CONFIG8	0x08	0x00	phaseadd(7:0)								
CONFIG9	0x09	0x00	phaseadd(15:8)								
CONFIG10	0x0A	0x00	phaseadd(23:16)								
CONFIG11	0x0B	0x00	phaseadd(31:24)								
CONFIG12	0x0C	0x00	qmc_gaina(7:0)								
CONFIG13	0x0D	0x00	qmc_gainb(7:0)								
CONFIG14	0x0E	0x00	qmc_phase(7:0)								
CONFIG15	0x0F	0x24	qmc_phase(9:8)		qmc_gaina(10:8)			qmc_gainb(10:8)			
CONFIG16	0x10	0x00	qmc_offseta(7:0)								
CONFIG17	0x11	0x00	qmc_offsetb(7:0)								
CONFIG18	0x12	0x00	qmc_offseta(12:8)						Unused	Unused	Unused
CONFIG19	0x13	0x00	qmc_offsetb(12:8)						Unused	Unused	Unused
CONFIG20	0x14	0x00	ser_dac_data(7:0)								
CONFIG21	0x15	0x00	ser_dac_data(15:8)								
CONFIG22	0x16	0x15	nco_sel(1:0)		nco_reg_sel(1:0)		qmcrr_reg_sel(1:0)		qmoffset_reg_sel(1:0)		
CONFIG23	0x17	0x15	Unused	Unused	fifo_sel(2:0)			aflag_sel	Unused	Unused	
CONFIG24	0x18	0x80	fifo_sync_strt(3:0)				Unused	Unused	Unused	Unused	
CONFIG25	0x19	0x00	Unused	Unused	Unused	Unused	Unused	Unused	Unused	Unused	
CONFIG26	0x1A	0x0E	io_1p8_3p3	Unused	sleepb	sleepa	isbiaslpf_a	isbiaslpf_b	Reserved	Reserved	
CONFIG27	0x1B	0xFF	coarse_daca(3:0)				coarse_dacb(3:0)				
CONFIG28	0x1C	0x00	Reserved								
CONFIG29	0x1D	0x00	Reserved								
CONFIG30	0x1E	0x00	Reserved								

Register name: STATUS0 - Address: 0x00, Default 0x03

Bit 7	Bit 6	Bit 5	Bit 4	Bit 3	Bit 2	Bit 1	Bit 0
Reserved	Unused	Unused	device_ID (2:0)			version(1:0)	
0	0	0	0	0	0	1	1

- device_ID(2:0) : Returns '000' for DAC5689. (Read Only)
- version(1:0) : A hardwired register that contains the version of the chip. (Read Only)

Register name: CONFIG1 Address: 0x01, Default 0x0B

Bit 7	Bit 6	Bit 5	Bit 4	Bit 3	Bit 2	Bit 1	Bit 0
inset_mode (1:0)		Unused	synchr_clkln	twos	inv_inclk	interp_valule(1:0)	
0	0	0	0	1	0	1	1

- inset_mode(1:0)** : Controls the expected format of the input data. For the interleaved modes, TXENABLE or the MSB of the port that does not have data can be used to tell the chip which sample is the A sample. For TXENABLE the sample aligned with the rising edge is A. For the MSB, it is presumed that this signal will toggle with A and B. The MSB should be '1' for A and '0' for B. (** See CONFIG23 **)

inset_mode	Function
00	Normal input on A and B.
01	Interleaved input on A, which is de-interleaved and placed on both A and B data paths. (** See CONFIG23 **)
10	Interleaved input on B, which is de-interleaved and placed on both A and B data paths. (** See CONFIG23 **)
11	Half rate data on A and B inputs. This data is merge together to form a single stream of data on the A data path.

- synchr_clkln** : This turns on the synchronous mode of the dual-clock in mode. In this mode, the CLK2/C and CLK1/C must be synchronous in phase since the slower clock is used to synchronize dividers in the clock distribution circuit.
- twos** : When set (default), the input data format is expected to be 2's complement. When cleared, the input is expected to be offset-binary.
- inv_inclk** : This allows the input clock, the clock driving the input side of the FIFO to be inverted. This allows easier registering of the data (more setup/hold time) in the single-clock mode of the device
- interp_valule(1:0)** : These bits define the interpolation factor:

interp_value	Interpolation Factor
00	1X
01	2X
10	4X
11	8X

Register name: CONFIG2 Address: 0x02, Default 0xE1

Bit 7	Bit 6	Bit 5	Bit 4	Bit 3	Bit 2	Bit 1	Bit 0
dualclk_ena	clkoff_off	Reserved	clkoff_SE_hold	fir4_ena	qmc_offset_ena	qmc_corr_ena	mixer_ena
1	1	1	0	0	0	0	1

- dualclk_ena** : When set (default), the device is in dual clock mode. A single-ended or differential clock at the data rate frequency must be input to CLK1/CLK1C. Otherwise, the device is in external clock mode.
- clkoff_off** : When cleared, the pin is configured to output an internally generated CLKO as a clock signal for the input data. Must be set (default) in dual clock mode.
- clkoff_SE_hold** : When set, the single ended (SE) clock is held to a value of '1' so that the signal doesn't toggle when using the differential clock input.
- fir4_ena** : When set, the FIR4 Inverse SINC filter is enabled. Otherwise it is bypassed
- qmc_offset_ena** : When set, the digital Quadrature Modulator Correction (QMC) offset correction circuitry is enabled.
- qmc_corr_ena** : When set, the QMC phase and gain correction circuitry is enabled.
- mixer_ena** : When set, the Full Mixer (FMIX) is enabled. Otherwise it is bypassed.

Register name: CONFIG3 Address: 0x03, Default 0x00

Bit 7	Bit 6	Bit 5	Bit 4	Bit 3	Bit 2	Bit 1	Bit 0
diffclk_dly(1:0)		clkoff_dly(1:0)		Reserved			
0	0	0	0	0	0	0	0

- diffclk_dly(1:0)** : To allow for a wider range of interfacing, the differential input clock has programmable delay added to its tree.

diffclk_dly	Approximate additional delay
00	0
01	1.0 ns
10	2.0 ns
11	3.0 ns

- clkoff_dly(1:0)** : Same as above except these bits effect the single ended or internally generated clock

Register name: CONFIG4 Address: 0x04, Default 0x00

Bit 7	Bit 6	Bit 5	Bit 4	Bit 3	Bit 2	Bit 1	Bit 0
ser_dac_data_ena	output_delay(1:0)		B_equals_A	A_equals_B	Unused	reva	revb
0	0	0	0	0	0	0	0

- ser_dac_data_ena** : Muxes the ser_dac_data(15:0) to both DACs when asserted.
- output_delay(1:0)** : Delays the output to both DACs from 0 to 3 DAC clock cycles
- B_equals_A** : When set, the DACA data is driving the DACB output.
- A_equals_B** : When set, the DACB data is driving the DACA output.

Bit 4 B_equals_A	Bit 3 A_equals_B	DACB Output	DACA Output	Description
0	0	B data	A data	Normal Output
0	1	B data	B data	Both DACs driven by B data
1	0	A data	A data	Both DACs driven by A data
1	1	A data	B data	Swapped Output

- reva** : Reverse the input bits of the A input port. MSB becomes LSB.
- revb** : Reverse the input bits of the B input port. MSB becomes LSB

Register name: CONFIG5 Address: 0x05, Default 0x22

Bit 7	Bit 6	Bit 5	Bit 4	Bit 3	Bit 2	Bit 1	Bit 0
sif4	sif_sync_sig	clkdiv_sync_ena	clkdiv_sync_sel	Reserved	clkdiv_shift	mixer_gain	Unused
0	0	1	0	0	0	1	0

- sif4** : When set, the serial interface (SIF) is a 4 bit interface, otherwise it is a 3 bit interface.
- sif_sync_sig** : SIF created sync signal. Set to '1' to cause a sync and then clear to '0' to remove it.
- clkdiv_sync_ena** : Enables syncing of the clock divider using the sync or TXENABLE pins when the bit is asserted.
- clkdiv_sync_sel** : Selects the input pin to sync the clock dividers. (0 = SYNC, 1 = TXENABLE)
- clkdiv_shift** : When set, a rising edge on the selected sync (see clkdiv_sync_sel) for the clock dividers will cause a slip in the synchronous counter by 1T and is useful for multi-DAC time alignment.
- mixer_gain** : When set, adds 6dB to the mixer gain output.

Register name: CONFIG6 Address: 0x06, Default 0x00 (Synced)

Bit 7	Bit 6	Bit 5	Bit 4	Bit 3	Bit 2	Bit 1	Bit 0
phaseoffset(7:0)							
0	0	0	0	0	0	0	0

phaseoffset(7:0) : See CONFIG7 below.

Register name: CONFIG7 Address: 0x07, Default 0x00 (Synced)

Bit 7	Bit 6	Bit 5	Bit 4	Bit 3	Bit 2	Bit 1	Bit 0
phaseoffset(15:8)							
0	0	0	0	0	0	0	0

phaseoffset(15:8) : This is the phase offset added to the NCO accumulator just before generation of the SIN and COS values. The phase offset is added to the upper 16bits of the NCO accumulator results and these 16 bits are used in the sin/cosine lookup tables.

Register name: CONFIG8 Address: 0x08, Default 0x00 (Synced)

Bit 7	Bit 6	Bit 5	Bit 4	Bit 3	Bit 2	Bit 1	Bit 0
phaseadd(7:0)							
0	0	0	0	0	0	0	0

phaseadd(7:0) : See CONFIG11 below.

Register name: CONFIG9 Address: 0x09, Default 0x00 (Synced)

Bit 7	Bit 6	Bit 5	Bit 4	Bit 3	Bit 2	Bit 1	Bit 0
phaseadd(15:8)							
0	0	0	0	0	0	0	0

phaseadd(15:8) : See CONFIG11 below.

Register name: CONFIG10 Address: 0x0A, Default 0x00 (Synced)

Bit 7	Bit 6	Bit 5	Bit 4	Bit 3	Bit 2	Bit 1	Bit 0
phaseadd(23:16)							
0	0	0	0	0	0	0	0

phaseadd(23:16) : See CONFIG11 below.

Register name: CONFIG11 Address: 0x0B, Default 0x00 (Synced)

Bit 7	Bit 6	Bit 5	Bit 4	Bit 3	Bit 2	Bit 1	Bit 0
phaseadd(31:24)							
0	0	0	0	0	0	0	0

phaseadd(31:24) : The Phaseadd(31:0) value is used to determine the frequency of the NCO. The two's complement formatted value can be positive or negative and the LSB is equal to $F_s/(2^{32})$.

Register name: CONFIG12 Address: 0x0C, Default 0x00 (Synced)

Bit 7	Bit 6	Bit 5	Bit 4	Bit 3	Bit 2	Bit 1	Bit 0
qmc_gaina(7:0)							
0	0	0	0	0	0	0	0

qmc_gaina(7:0) : Lower 8 bits of the 11-bit Quadrature Modulator Correction (QMC) gain word for DACA. The upper 3 bits are in the CONFIG15 register. The full 11-bit `qmc_gaina(10:0)` word is formatted as UNSIGNED with a range of 0 to 1.9990 and the default gain is 1.0000. The implied decimal point for the multiplication is between bit 9 and bit 10. Refer to formatting reference below.

qmc_gaina(10:0) [Binary]	qmc_gaina(10:0) [Decimal]	Format	Gain Value
0000000000	0	$0 + 0/1024 =$	0.0000000
0000000001	1	$0 + 1/1024 =$	0.0009766
.....
0111111111	1023	$0 + 1023/1024 =$	0.9990234
1000000000	[Default] 1024	$1 + 0/1024 =$	1.0000000
1000000001	1025	$1 + 1/1024 =$	1.0009766
.....
1111111111	2047	$1 + 1023/1024 =$	1.9990234

Register name: CONFIG13 Address: 0x0D, Default 0x00 (Synced)

Bit 7	Bit 6	Bit 5	Bit 4	Bit 3	Bit 2	Bit 1	Bit 0
qmc_gainb(7:0)							
0	0	0	0	0	0	0	0

qmc_gainb(7:0) : Lower 8 bits of the 11-bit QMC gain word for DACB. The upper 3 bits are in CONFIG15 register. Refer to CONFIG12 above for formatting.

Register name: CONFIG14 Address: 0x0E, Default 0x00 (Synced)

Bit 7	Bit 6	Bit 5	Bit 4	Bit 3	Bit 2	Bit 1	Bit 0
qmc_phase(7:0)							
0	0	0	0	0	0	0	0

qmc_phase(7:0) : Lower 8 bits of the 10-bit Quadrature Modulator Correction (QMC) phase word. The upper 2 bits are in the CONFIG15 register. The full 11-bit **qmc_phase(9:0)** correction word is formatted as two's complement and scaled to occupy a range of -0.125 to 0.12475 and a default phase correction 0.00. To accomplish QMC phase correction, this value is multiplied by the current 'Q' sample, then summed into the 'I' sample. Refer to formatting reference below.

qmc_phase(9:0) [Binary]	qmc_phase(9:0) [Decimal]	Format	Phase Correction
1000000000	-512	$(-1 + 0/512) / 8 =$	-0.1250000
1000000001	-511	$(-1 + 1/512) / 8 =$	-0.1234559
.....
1111111111	-1	$(-1 + 511/512) / 8 =$	-0.0002441
0000000000	[Default] 0	$(+0 + 0/512) / 8 =$	+0.0000000
0000000001	1	$(+0 + 1/512) / 8 =$	+0.0002441
.....
0111111111	511	$(+0 + 511/512) / 8 =$	+0.1247559

Register name: CONFIG15 Address: 0x0F, Default 0x24 (Synced)

Bit 7	Bit 6	Bit 5	Bit 4	Bit 3	Bit 2	Bit 1	Bit 0
qmc_phase(9:8)		qmc_gaina(10:8)			qmc_gainb(10:8)		
0	0	1	0	0	1	0	0

qmc_phase(9:8) : Upper 2 bits of **qmc_phase** term. Defaults to zero.
qmc_gaina(10:8) : Upper 3 bits of **qmc_gaina** term. Defaults to unity gain.
qmc_gainb(10:8) : Upper 3 bits of the **qmc_gainb** term. Defaults to unity gain.

Register name: CONFIG16 Address: 0x10, Default 0x00 (Synced)

Bit 7	Bit 6	Bit 5	Bit 4	Bit 3	Bit 2	Bit 1	Bit 0
qmc_offseta(7:0)							
0	0	0	0	0	0	0	0

qmc_offseta(7:0) : Lower 8 bits of the DACA offset correction. The upper 5 bits are in CONFIG18 register. The offset is measured in DAC LSBs.

Register name: CONFIG17 Address: 0x11, Default 0x00 (Synced)

Bit 7	Bit 6	Bit 5	Bit 4	Bit 3	Bit 2	Bit 1	Bit 0
qmc_offsetb(7:0)							
0	0	0	0	0	0	0	0

qmc_offsetb(7:0) : Lower 8 bits of the DACB offset correction. The upper 5 bits are in CONFIG19 register. The offset is measured in DAC LSBs.

Register name: CONFIG18 Address: 0x12, Default 0x00 (Synced)

Bit 7	Bit 6	Bit 5	Bit 4	Bit 3	Bit 2	Bit 1	Bit 0
qmc_offseta(12:8)					Unused	Unused	Unused
0	0	0	0	0	0	0	0

qmc_offseta(12:8) : Upper 5 bits of the DACA offset correction.

Register name: CONFIG19 Address: 0x13, Default 0x00 (Synced)

Bit 7	Bit 6	Bit 5	Bit 4	Bit 3	Bit 2	Bit 1	Bit 0
qmc_offsetb(12:8)					Unused	Unused	Unused
0	0	0	0	0	0	0	0

qmc_offsetb(12:8) : Upper 5 bits of the DACB offset correction.

Register name: CONFIG20 Address: 0x14, Default 0x00

Bit 7	Bit 6	Bit 5	Bit 4	Bit 3	Bit 2	Bit 1	Bit 0
ser_dac_data(7:0)							
0	0	0	0	0	0	0	0

ser_dac_data(7:0) : Lower 8 bits of the serial interface controlled DAC value. This data is routed to both DACs when enabled via **ser_dac_data_ena** in CONFIG4. Value is expected in 2's complement format.

Register name: CONFIG21 Address: 0x15, Default 0x00

Bit 7	Bit 6	Bit 5	Bit 4	Bit 3	Bit 2	Bit 1	Bit 0
ser_dac_data(15:8)							
0	0	0	0	0	0	0	0

ser_dac_data(15:8) : Upper 8 bits of the serial interface controlled DAC value. This data is routed to both DACs when enabled via **ser_dac_data_ena** in CONFIG4. Value is expected in 2's complement format.

Register name: CONFIG22 Address: 0x16, Default 0x15

Bit 7	Bit 6	Bit 5	Bit 4	Bit 3	Bit 2	Bit 1	Bit 0
nco_sel(1:0)		nco_reg_sel(1:0)		qmcorr_reg_sel(1:0)		qmoffset_reg_sel(1:0)	
0	0	0	1	0	1	0	1

nco_sel(1:0) : Selects the signal to use as the sync for the NCO accumulator.

nco_reg_sel(1:0) : Selects the signal to use as the sync for loading the NCO registers.

qmcorr_reg_sel(1:0) : Selects the signal to use as the sync for loading the QM correction registers.

qmoffset_reg_sel(1:0) : Selects the signal to use as the sync for loading the QM offset correction registers.

*_sel (1:0)	Sync selected
00	TXENABLE from FIFO output
01	SYNC from FIFO output
10	sync_SIF_sig (via CONFIG5)
11	Always zero

Register name: CONFIG23 Address: 0x17, Default 0x15

Bit 7	Bit 6	Bit 5	Bit 4	Bit 3	Bit 2	Bit 1	Bit 0
Unused	Unused	fifo_sel(2:0)			aflag_sel	Unused	Unused
0	0	0	1	0	1	0	1

fifo_sel(2:0) : Selects the sync source for the FIFO from the table below. For the case where the sync is dependent on the first transition of the input data MSB: Once the transition occurs, the only way to get another sync it to reset the device or to program **fifo_sel** to another value

fifo_sel (2:0)	Sync selected
000	TXENABLE from pin
001	SYNC from pin
010	sync_SIF_sig (via CONFIG5)
011	Always zero
100	1 st transition on DA MSB
101	1 st transition on DB MSB
110	Always zero
111	Always one

aflag_sel : When set, the MSB of the input opposite of incoming data is used to determine the A sample. When cleared, rising edge of TXENABLE is used. Refer to [Figure 31](#).

Register name: CONFIG24 Address: 0x18, Default 0x80

Bit 7	Bit 6	Bit 5	Bit 4	Bit 3	Bit 2	Bit 1	Bit 0
fifo_sync_strt(3:0)				Unused	Unused	Unused	Unused
1	0	0	0	0	0	0	0

fifo_sync_strt(3:0) : When the sync to the FIFO occurs, this is the value loaded into the FIFO output position counter. With this value the initial difference between input and output pointers can be controlled. This may be helpful in syncing multiple chips or controlling the delay through the device.

Register name: CONFIG25 Address: 0x19, Default 0x00

Bit 7	Bit 6	Bit 5	Bit 4	Bit 3	Bit 2	Bit 1	Bit 0
Unused	Unused	Unused	Unused	Unused	Unused	Unused	Unused
0	0	0	0	0	0	0	0

Register name: CONFIG26 Address: 0x1A, Default 0x0E

Bit 7	Bit 6	Bit 5	Bit 4	Bit 3	Bit 2	Bit 1	Bit 0
io_1p8_3p3	Unused	sleepb	sleepa	isbiaslpfb_a	isbiaslpfb_b	Reserved ⁽¹⁾	Reserved ⁽²⁾
0	0	0	0	1	1	1	0

- io_1p8_3p3** : Used to program the digital input voltage threshold levels. '0'=3.3V tolerate pads and '1'=1.8V tolerate pads. Applies to following digital pins: DA[15:0], DB[15:0], SYNC, RESETB, SCLK, SDENB, SDIO (input only) and TXENABLE.
- sleepb** : When set, DACB is put into sleep mode. Putting the DAC into single DAC mode does not automatically assert this signal, so for minimum power in single DAC mode, also program this register bit.
- sleepa** : When set, DACA is put into sleep mode. Note: If DACA channel is in sleep mode (**sleepa** = '1') the DACB channel is also forced in to sleep mode.
- isbiaslpfb_a** : Turns on the low pass filter for the current source bias in the DACA when cleared. The low pass filter will set a corner at ~472 kHz when low and ~95 kHz when high.
- isbiaslpfb_b** : Turns on the low pass filter for the current source bias in the DACB when cleared. The low pass filter will set a corner at ~472 kHz when low and ~95 kHz when high.

(1) Default value is 0. Must be set to 1 for proper operation.

(2) Default value is 1. Must be set to 0 for proper operation.

Register name: CONFIG27 Address: 0x1B, Default 0xFF

Bit 7	Bit 6	Bit 5	Bit 4	Bit 3	Bit 2	Bit 1	Bit 0
coarse_daca(3:0)				coarse_dacb(3:0)			
1	1	1	1	1	1	1	1

coarse_daca(3:0) : Scales the output current is 16 equal steps.

$$\frac{V_{EXTIO}}{R_{bias}} \times (DACA_gain + 1)$$

coarse_dacb(3:0) : Same as above except for DACB.

Register name: CONFIG28 Address: 0x1C, Default 0x00

Bit 7	Bit 6	Bit 5	Bit 4	Bit 3	Bit 2	Bit 1	Bit 0
Reserved							
0	0	0	0	0	0	0	0

Register name: CONFIG29 Address: 0x1D, Default 0x00

Bit 7	Bit 6	Bit 5	Bit 4	Bit 3	Bit 2	Bit 1	Bit 0
Reserved							
0	0	0	0	0	0	0	0

Register name: CONFIG30 Address: 0x1E, Default 0x00

Bit 7	Bit 6	Bit 5	Bit 4	Bit 3	Bit 2	Bit 1	Bit 0
Reserved							
0	0	0	0	0	0	0	0

DETAILED DESCRIPTION

EXAMPLE SYSTEM DIAGRAM

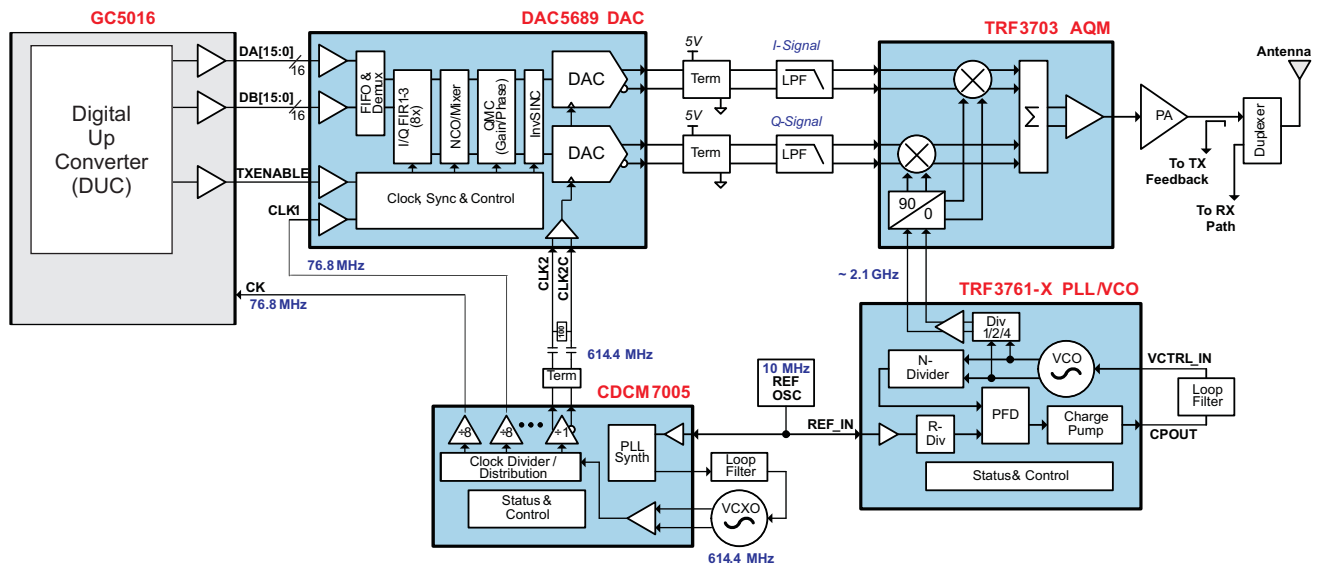

Figure 15. Example System Diagram: Direct Conversion with 8x Interpolation

SERIAL INTERFACE

The serial port of the DAC5689 is a flexible serial interface which communicates with industry standard microprocessors and microcontrollers. The interface provides read/write access to all registers used to define the operating modes of DAC5689. It is compatible with most synchronous transfer formats and can be configured as a 3 or 4 pin interface by **SIF4** in register **CONFIG5**. In both configurations, **SCLK** is the serial interface input clock and **SDENB** is serial interface enable. For 3 pin configuration, **SDIO** is a bidirectional pin for both data in and data out. For 4 pin configuration, **SDIO** is data in only and **SDO** is data out only. Data is input into the device with the rising edge of **SCLK**. Data is output from the device on the falling edge of **SCLK**.

Each read/write operation is framed by signal **SDENB** (Serial Data Enable Bar) asserted low for 2 to 5 bytes, depending on the data length to be transferred (1–4 bytes). The first frame byte is the instruction cycle which identifies the following data transfer cycle as read or write, how many bytes to transfer, and what address to transfer the data. [Table 2](#) indicates the function of each bit in the instruction cycle and is followed by a detailed description of each bit. Frame bytes 2 to 5 comprise the data transfer cycle.

Table 2. Instruction Byte of the Serial Interface

Bit	7	6	5	4	3	2	1	0
Description	R/W	N1	N0	A4	A3	A2	A1	A0

R/W Identifies the following data transfer cycle as a read or write operation. A high indicates a read operation from DAC5689 and a low indicates a write operation to DAC5689.

[N1 : N0] Identifies the number of data bytes to be transferred per Table 3. Data is transferred MSB first.

Table 3. Number of Transferred Bytes Within One Communication Frame

N1	N0	DESCRIPTION
0	0	Transfer 1 Byte
0	1	Transfer 2 Bytes
1	0	Transfer 3 Bytes
1	1	Transfer 4 Bytes

[A4 : A0] Identifies the address of the register to be accessed during the read or write operation. For multi-byte transfers, this address is the starting address. Note that the address is written to the DAC5689 MSB first and counts down for each byte

Figure 16 shows the serial interface timing diagram for a DAC5689 write operation. **SCLK** is the serial interface clock input to DAC5689. Serial data enable **SDENB** is an active low input to DAC5689. **SDIO** is serial data in. Input data to DAC5689 is clocked on the rising edges of **SCLK**.

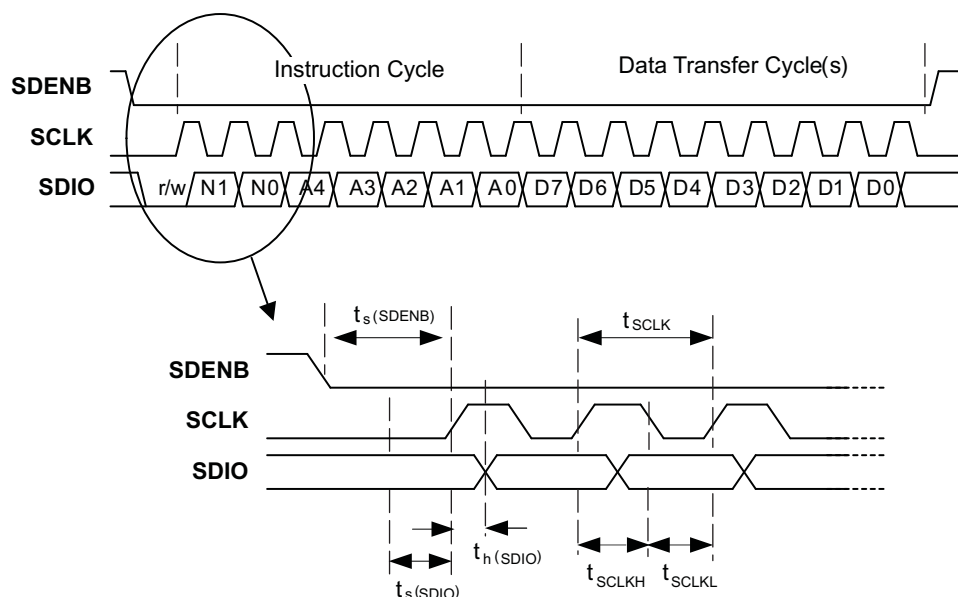

Figure 16. Serial Interface Write Timing Diagram

Figure 17 shows the serial interface timing diagram for a DAC5689 read operation. **SCLK** is the serial interface clock input to DAC5689. Serial data enable **SDENB** is an active low input to DAC5689. **SDIO** is serial data in during the instruction cycle. In 3 pin configuration, **SDIO** is data out from DAC5689 during the data transfer cycle(s), while **SDO** is in a high-impedance state. In 4 pin configuration, **SDO** is data out from DAC5689 during the data transfer cycle(s). The **SDIO/SDO** data is output on the falling edge of **SCLK**. At the end of the data transfer, **SDO** will output low on the final falling edge of **SCLK** until the rising edge of **SDENB** when it will 3-state.

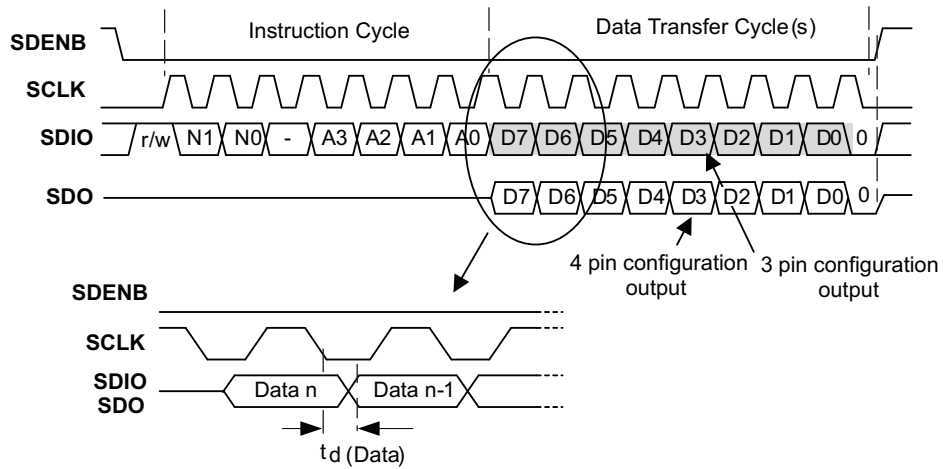

Figure 17. Serial Interface Read Timing Diagram

FIR FILTERS

Figure 18 shows the magnitude spectrum response for FIR1, a 67-tap interpolating half-band filter. The transition band is from 0.4 to $0.6 \times f_{IN}$ (the input data rate for the FIR filter) with <0.002 -dB of pass-band ripple and > 80 -dB stop-band attenuation. Figure 19 shows the transition band region from 0.37 to $0.47 \times f_{IN}$. Up to $0.458 \times f_{IN}$ there is less than 0.5 dB of attenuation.

Figure 20 shows the magnitude spectrum response for the 19-tap FIR2 filter. The transition band is from 0.25 to $0.75 \times f_{IN}$ (the input data rate for the FIR filter). For 4x interpolation modes, the composite filter response is shown in Figure 21.

Figure 22 shows the magnitude spectrum response for the 11-tap FIR3 filter. For 8x interpolation modes, the composite filter response is shown in Figure 23.

The DAC5689 also has a 9-tap non-interpolating inverse sinc filter (FIR4) running at the DAC update rate (f_{DAC}) that can be used to flatten the frequency response of the sample and hold output. The DAC sample and hold output set the output current and holds it constant for one DAC clock cycle until the next sample, resulting in the well known $\sin(x)/x$ or $\text{sinc}(x)$ frequency response shown in Figure 24 (red dash-dotted line). The inverse sinc filter response (Figure 24, blue dashed line) has the opposite frequency response between 0 to $0.4 \times f_{DAC}$, resulting in the combined response (Figure 24, green solid line). Between 0 to $0.4 \times f_{DAC}$, the inverse sinc filter compensates the sample and hold rolloff with less than 0.03 -dB error.

The inverse sinc filter has a gain > 1 at all frequencies. Therefore, the signal input to FIR4 must be reduced from full scale to prevent saturation in the filter. The amount of backoff required depends on the signal frequency, and is set such that at the signal frequencies the combination of the input signal and filter response is less than 1 (0 dB). For example, if the signal input to FIR4 is at $0.25 \times f_{DAC}$, the response of FIR4 is 0.9 dB, and the signal must be backed off from full scale by 0.9 dB. The gain function in the QMC block can be used to set reduce amplitude of the input signal. The advantage of FIR4 having a positive gain at all frequencies is that the user is then able to optimized backoff of the signal based on the signal frequency.

The filter taps for all digital filters are listed in Table 4. Note that the loss of signal amplitude may result in lower SNR due to decrease in signal amplitude.

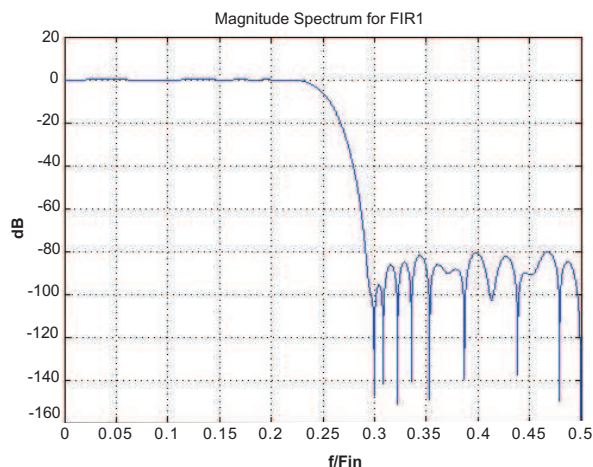

Figure 18. Magnitude Spectrum for FIR1

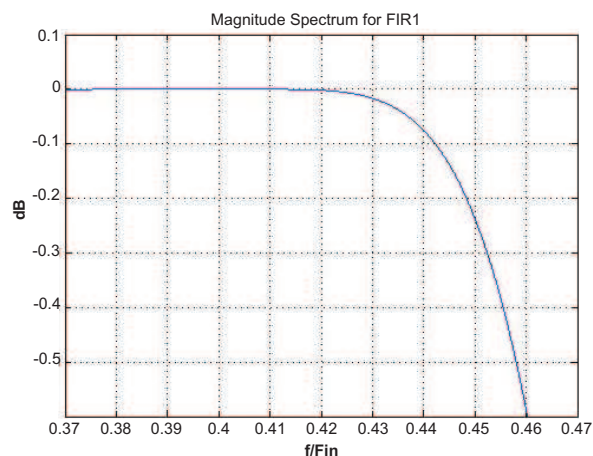

Figure 19. FIR1 Transition Band

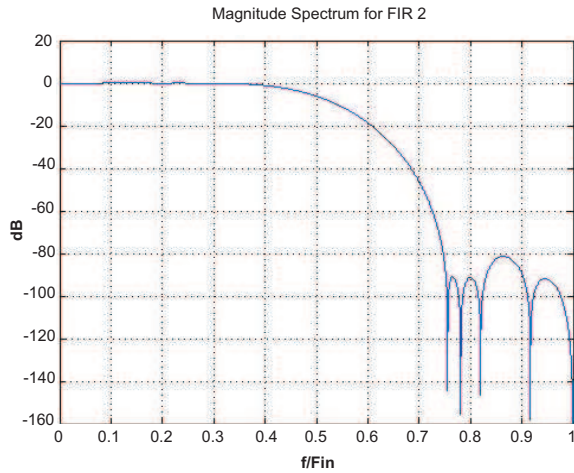

Figure 20. Magnitude Spectrum for FIR2

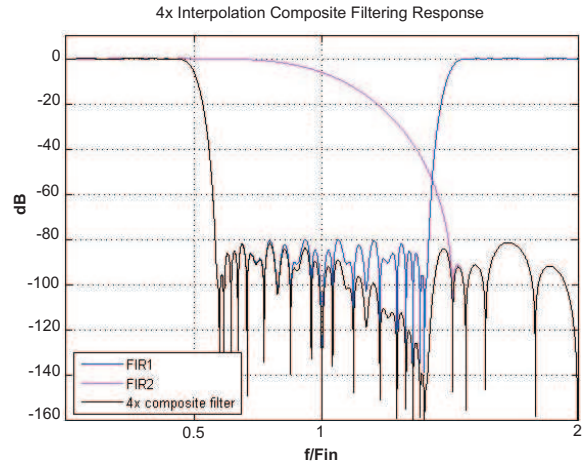

Figure 21. 4x Interpolation Composite Response

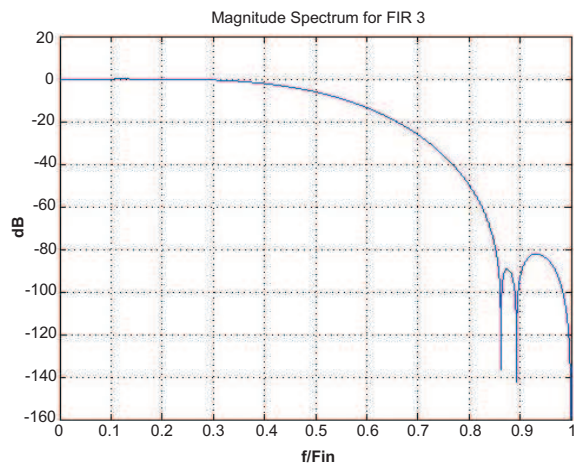

Figure 22. Magnitude Spectrum for FIR3

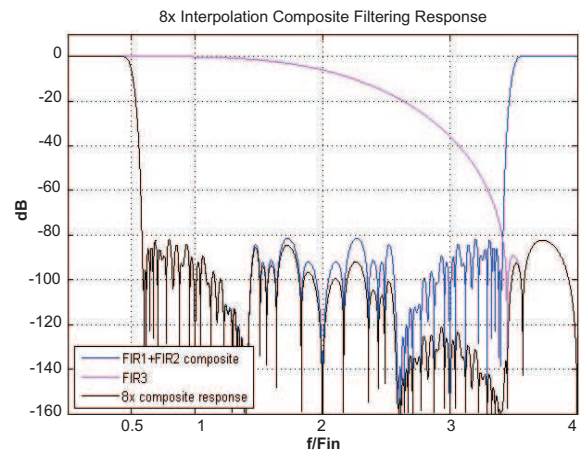

Figure 23. 8x Interpolation Composite Response

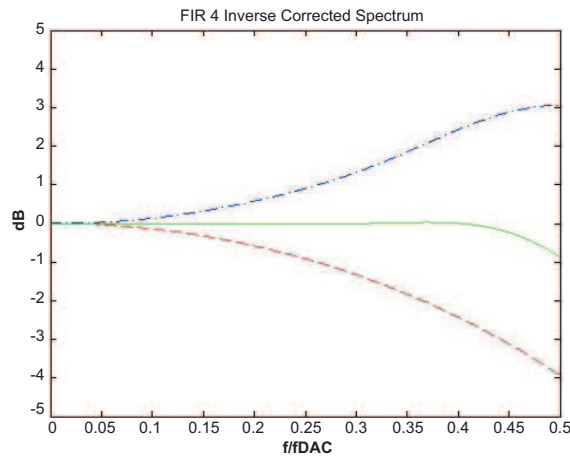

Figure 24. Magnitude Spectrum for FIR4

Table 4. FIR Filter Coefficients

2X INTERPOLATING HALF-BAND FILTERS						NON-INTERPOLATING INVERSE-SINC FILTER	
FIR1		FIR2		FIR3		FIR4	
67 Taps		19 Taps		11 Taps		9 Taps	
2	2	9	9	31	31	1	1
0	0	0	0	0	0	-4	-4
-5	-5	-58	-58	-219	-219	13	13
0	0	0	0	0	0	-50	-50
11	11	214	214	1212	1212	592⁽¹⁾	
0	0	0	0	2048⁽¹⁾			
-21	-21	-638	-638				
0	0	0	0				
37	37	2521	2521				
0	0	4096⁽¹⁾					
-61	-61						
0	0						
97	97						
0	0						
-148	-148						
0	0						
218	218						
0	0						
-314	-314						
0	0						
444	444						
0	0						
-624	-624						
0	0						
877	877						
0	0						
-1260	-1260						
0	0						
1916	1916						
0	0						
-3372	-3372						
0	0						
10395	10395						
16384⁽¹⁾							

 (1) Center taps are highlighted in **BOLD**.

Full Complex Mixer (FMIX)

The full complex Mixer (FMIX) block uses a Numerically Controlled Oscillator (NCO) with a 32-bit frequency register **freq(31:0)** and a 16-bit phase register **phase(15:0)** to provide sin and cos for mixing. The NCO tuning frequency is programmed in CONFIG8 through CONFIG11 registers. Phase offset is programmed in CONFIG6 and CONFIG7 registers. A block-diagram of the NCO is shown below in [Figure 25](#).

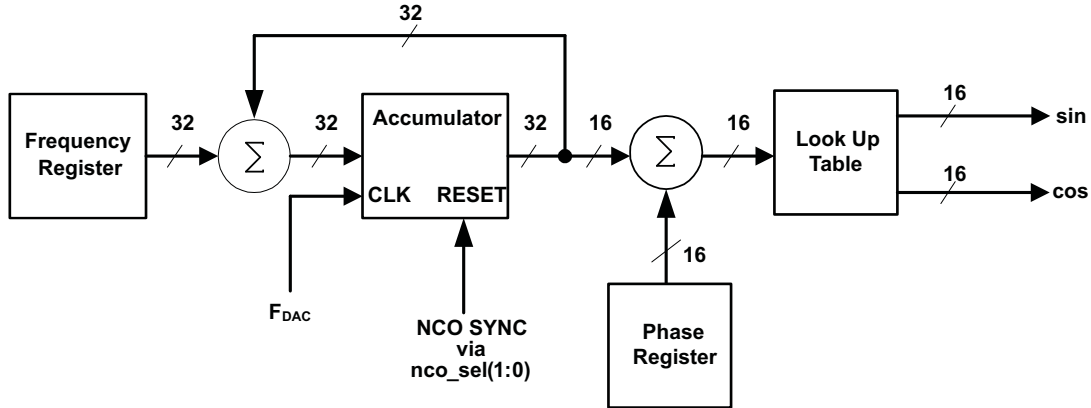

Figure 25. Block-Diagram of the NCO

Synchronization of the NCO occurs by resetting the NCO accumulator to zero. The synchronization source is selected by CONFIG22 **nco_sel(1:0)**. Frequency word **freq** in the frequency register is added to the accumulator every clock cycle, f_{DAC} . The output frequency of the NCO is

$$f_{NCO} = \frac{f_{ref} \times f_{NCO_CLK}}{2^{32}} \tag{1}$$

Treating channels A and B as a complex vector $I + IxQ$ where $I(t) = A(t)$ and $Q(t) = B(t)$, the output of FMIX $I_{OUT}(t)$ and $Q_{OUT}(t)$ is

$$I_{OUT}(t) = (I_{IN}(t) \cos(2\pi f_{NCO}t + \delta) - Q_{IN}(t) \sin(2\pi f_{NCO}t + \delta)) \times 2^{(mixer_gain - 1)} \tag{2}$$

$$Q_{OUT}(t) = (I_{IN}(t) \sin(2\pi f_{NCO}t + \delta) + Q_{IN}(t) \cos(2\pi f_{NCO}t + \delta)) \times 2^{(mixer_gain-1)} \tag{3}$$

Where t is the time since the last resetting of the NCO accumulator, δ is the phase offset value and **mixer_gain** is either 0 or 1. δ is given by:

$$\delta = 2\pi \times \text{phase}(15 : 0) / 2^{16} \tag{4}$$

The maximum output amplitude of FMIX occurs if $I_{IN}(t)$ and $Q_{IN}(t)$ are simultaneously full scale amplitude and the sine and cosine arguments $2\pi f_{NCO}t + \delta (2N-1)\times\pi/4$ ($N = 1, 2, \dots$).

With CONFIG5 **mixer_gain** = 0, the gain through FMIX is $\text{sqrt}(2)/2$ or -3 dB. This loss in signal power is in most cases undesirable, and it is recommended that the gain function of the QMC block be used to increase the signal by 3 dB to compensate. With **mixer_gain** = 1, the gain through FMIX is $\text{sqrt}(2)$ or + 3 dB, which can cause clipping of the signal if $I_{IN}(t)$ and $Q_{IN}(t)$ are simultaneously near full scale amplitude and should therefore be used with caution.

Quadrature Modulator Correction (QMC)

The Quadrature Modulator Correction (QMC) block provides a means for changing the phase balance of the complex signal to compensate for I and Q imbalance present in an analog quadrature modulator. The block diagram for the QMC block is shown in Figure 26. The QMC block contains 3 programmable parameters. Registers **qmc_gaina(10:0)** and **qmc_gainb(10:0)** control the I and Q path gains and are 11 bit values with a range of 0 to approximately 2.0. Note that the I and Q gain can also be controlled by setting the DAC full scale output current (see below). Register **qmc_phase(9:0)** controls the phase imbalance between I and Q and is a 10-bit value with a range of $-1/8$ to approximately $+1/8$. LO feedthrough can be minimized by adjusting the DAC offset feature described below.

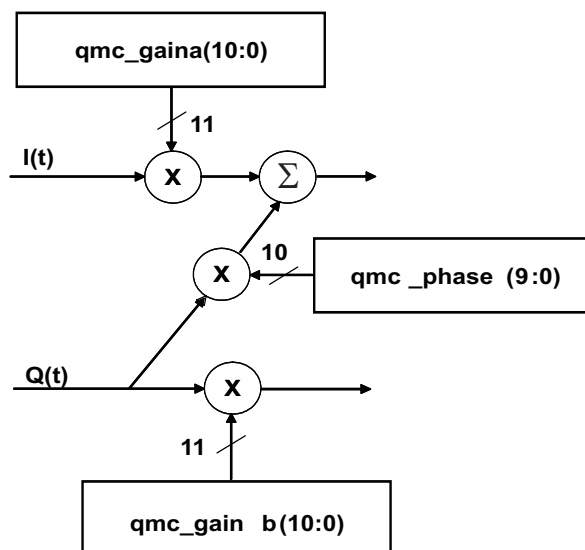

Figure 26. QMC Block Diagram

DAC Offset Control

Registers **qmc_offseta(12:0)** and **qmc_offsetb(12:0)** control the I and Q path offsets and are 13-bit values with a range of -4096 to 4095 . The DAC offset value adds a digital offset to the digital data before digital-to-analog conversion. The **qmc_gaina** and **qmc_gainb** registers can be used to backoff the signal before the offset to prevent saturation when the offset value is added to the digital signal.

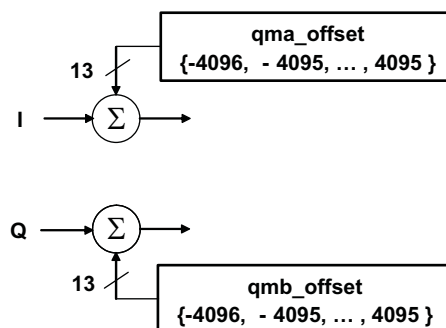

Figure 27. DAC Offset Block

CLOCK MODES

The DAC5689 supports several different clocking modes for generating the internal clocks for the logic and DAC. The clocking modes are selected by programming the register bits below and summarized in [Table 5](#).

Register	Control Bits
CONFIG1	synchr_clkin
CONFIG2	clko_off, dualclk_ena

Table 5. Summary of Clock Modes and Options

CLOCKING MODE	CLKO_ CLK1 I/O	PROGRAMMING BITS		
		synchr_clkin	clko_off	dualclk_ena
Dual Synchronous Clock Mode	Input	1	1	1
Dual Clock Mode	Input	0	1	1
External Clock Mode	Output	0	0	0

DAC5688 and DAC5689 CLOCK MODES

The DAC5689 is pin upgradeable to the DAC5688 which includes a 2x-32x clock multiplying PLL/VCO. This feature is useful when a high-rate clock is not available at the system level. The limitation of using the PLL is that the internal VCO phase noise degrades the quality of the DAC output signal when compared to the results obtained with an external low jitter clock source.

In addition to the PLL mode in the DAC5688 there are other differences in the available clock configurations for both devices as listed in [Table 6](#). Aside for the clock mode differences, the functionality and performance of both devices is identical.

Table 6. DAC5688 and DAC5689 Clock Modes Comparison

CLOCKING MODE	OPTION	DAC5688		DAC5689		COMMENT
		CLKO_CLK1 I/O	CLK1C I/O	CLKO_CLK1 I/O	CLK1C I/O	
Dual Synchronous Clock Mode	Diff. CLK1/C	Input	Input	Input	Input	This mode is identical in both devices.
	S/E CLK1	Input	Open	Input or AC coupled to GND	Input or AC coupled to GND	This mode is not recommended.
Dual Clock Mode	Diff. CLK1/C	Input	Input	Input	Input	This mode is identical in both devices.
	S/E CLK1	Input	Open	Input or AC coupled to GND	Input or AC coupled to GND	The unused input on the DAC5689 must be AC coupled to GND.
External Clock Mode	CLKO	Output Max. 160MHz with 3pF load	Open	Output Max. 185MHz with 6pF load	Open	The CLKO drive strenght is improved in the DAC5689.
PLL Clock Mode	Diff. CLK1/C	Input	Input	Not available		The DAC5689 does not support the PLL clock mode.
	S/E CLK1	Input	Open or PLL Lock Output			
	CLKO	Output Max. 160MHz with 3pF load	Open or PLL Lock Output			

DUAL SYNCHRONOUS CLOCK MODE

In DUAL SYNCHRONOUS CLOCK MODE, the user provides the CLK2/C clock signal at the DAC sample rate and also provides a divided down CLK1 at the input data rate. Refer to Figure 28 for the timing diagram. In this mode the relationship between CLK2 and CLK1 (t_{align}) is critical and used as a synchronizing mechanism for the internal logic. This facilitates multi-DAC synchronization by using dual external clock inputs CLK1 and CLK2 while FIFO data is always written and read from location zero. It is highly recommended that a clock synchronizer device such as the CDCM7005 provide both CLK2/C and CLK1/C inputs. Although CLK1 could be single-ended it is recommended to use a differential clock to ensure proper skews between the two clock inputs.

DUAL CLOCK MODE

In DUAL CLOCK MODE, the user provides the CLK2/C clock signal at the DAC sample rate and also provides a divided down CLK1 at the input data rate. The CLK1 signal can be differential or single-ended. If single-ended either CLK1 or CLK1C can be used as input as long as the unused input is AC coupled to GND. Refer to Figure 28 for the timing diagram. Unlike the DUAL SYNCHRONOUS CLOCK MODE, the t_{align} parameter is not critical because these clocks are not used as a synchronizing mechanism for the internal logic and the FIFO is used as an elastic buffer for the data. Synchronizing in this mode is provided by separate control inputs.

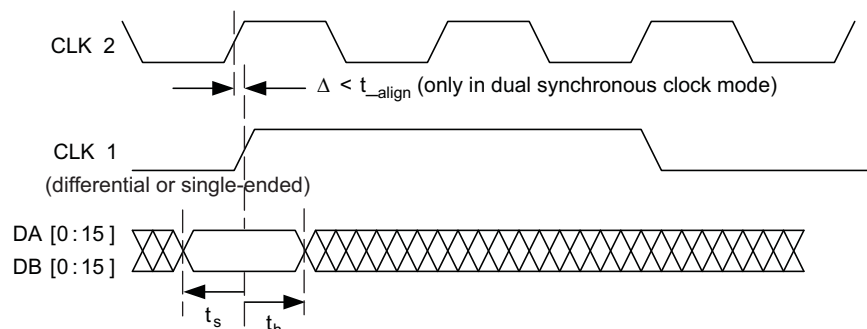

Figure 28. DUAL (SYNCHRONOUS) CLOCK MODE Timing Diagram

EXTERNAL CLOCK MODE

In EXTERNAL CLOCK MODE, the user provides a clock signal at the DAC output sample rate through CLK2/C. The CLKO_CLK1 pin is configured as an output in this mode and will toggle at a required frequency for the configured interpolation rate and data mode. The CLKO_CLK1 clock can be used to drive the input data source (such as digital upconverter) that sends the data to the DAC. Note that the CKO_CLK1 delay relative to the input CLK2 rising edge ($t_{d(CLKO)}$) in Figure 29 will increase with increasing loads.

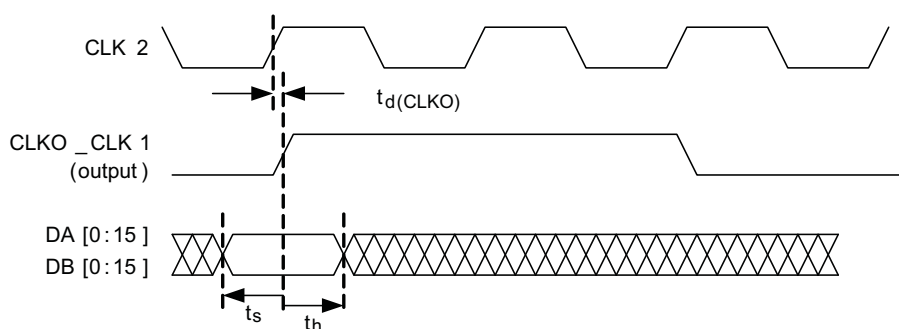

Figure 29. EXTERNAL CLOCK MODE Timing Diagram

DATA BUS MODES

The DAC5689 supports three DATA BUS MODES:

1. DUAL BUS MODE
2. INTERLEAVED BUS MODE
3. HALF RATE BUS MODE

DUAL BUS MODE

In DUAL BUS MODE, the user inputs data on both DA[15:0] and DB[15:0] ports. This mode is selected by setting CONFIG1 **insel_mode(1:0)** = '00'. Refer to [Figure 30](#).

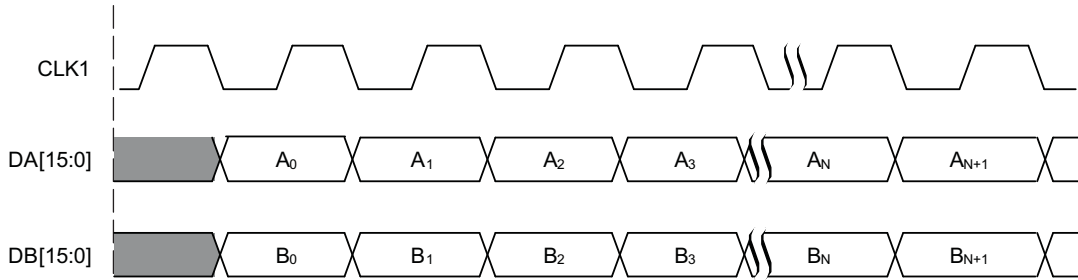

Figure 30. DUAL BUS MODE (Dual Clock Mode)

INTERLEAVED BUS MODE

In INTERLEAVED BUS MODE, the user inputs dual-channel data as an interleaved single data stream to either DA[15:] or DB[15:0] ports. The DAC5689 de-interleaves the input data stream and routes to both A and B data paths. For input data on DA[15:0], set CONFIG1 **insel_mode[15:0]** = '01'. For input data on DB[15:0], set CONFIG1 **insel_mode[15:0]** = '10'. In this bus mode, a separate input flag is required to distinguish an A sample from a B sample in the interleaved data stream. This flag can either be the single event rising edge of TXENABLE or the continuous toggling MSB of the port inactive data port. For the TXENABLE flag option, set the CONFIG23 **aflag_sel** bit and the A sample will be expected to be aligned with the rising edge of TXENABLE. For the toggling MSB option, clear the CONFIG23 **aflag_sel** bit and the A sample will be expected for each '1' of the MSB with the B sample is flagged for each '0' of the MSB. Refer to [Figure 31](#).

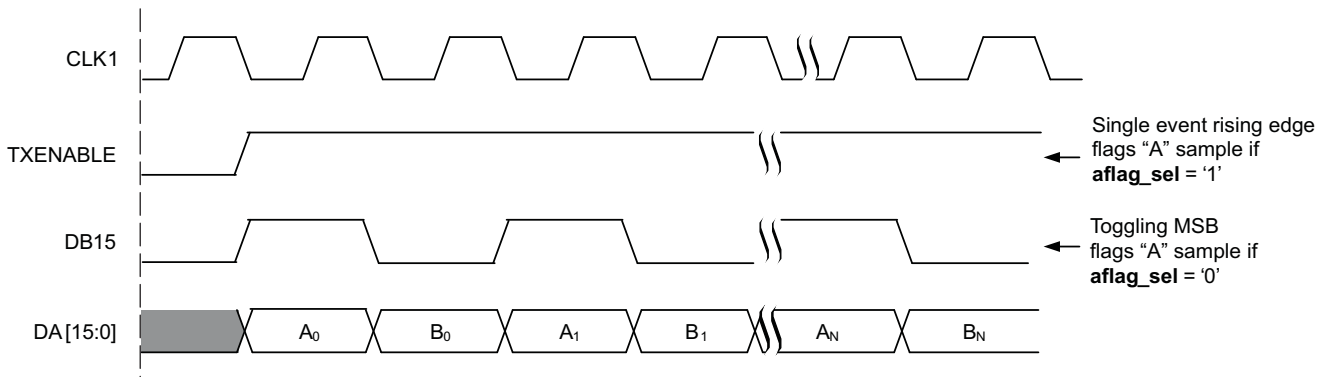

Figure 31. INTERLEAVED BUS MODE on DA[15:0] Port (Dual Clock Mode)

HALF RATE BUS MODE

In HALF RATE BUS MODE, the user inputs data on both DA[15:0] and DB[15:0] ports at half rate and input logic merges both data streams into one DAC channel (A). This mode is selected by setting CONFIG1 `inssel_mode[15:0] = '11'`. Refer to [Figure 32](#).

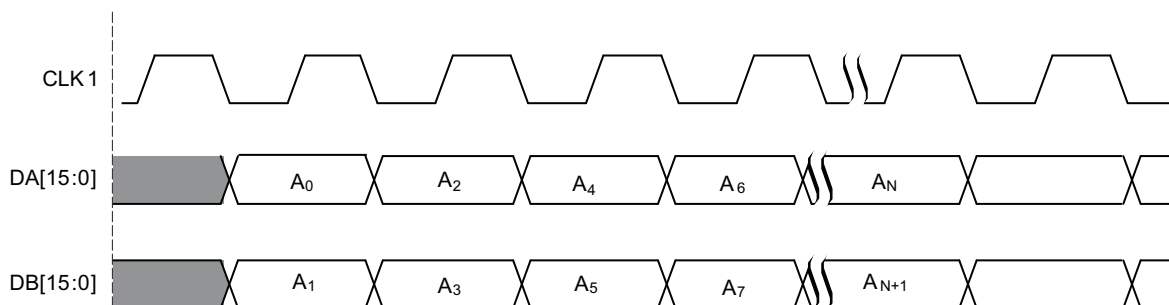

Figure 32. HALF RATE BUS MODE (Dual Clock Mode)

CLK2 and CLK2C Inputs

Figure 33 shows an equivalent circuit for the DAC input clock (CLK2/C).

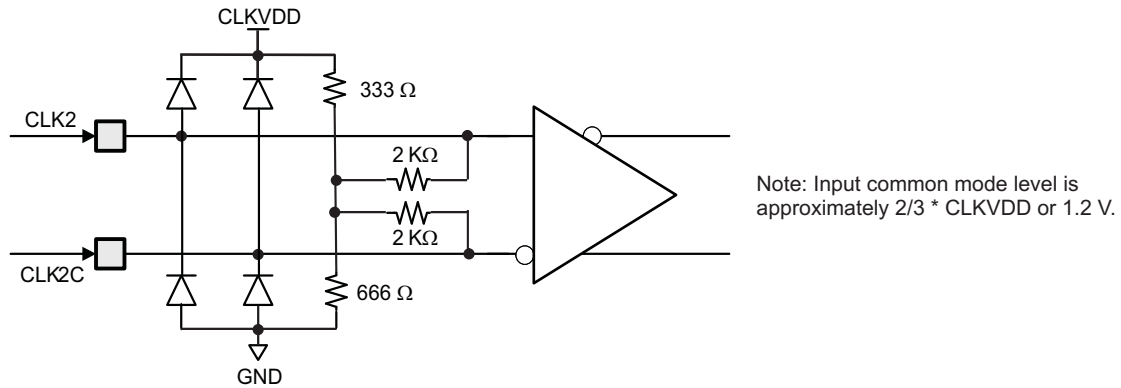

Figure 33. CLK2/C Equivalent Input Circuit

Figure 34 shows the preferred configuration for driving the CLK2/CLK2C input clock with a differential ECL/PECL source.

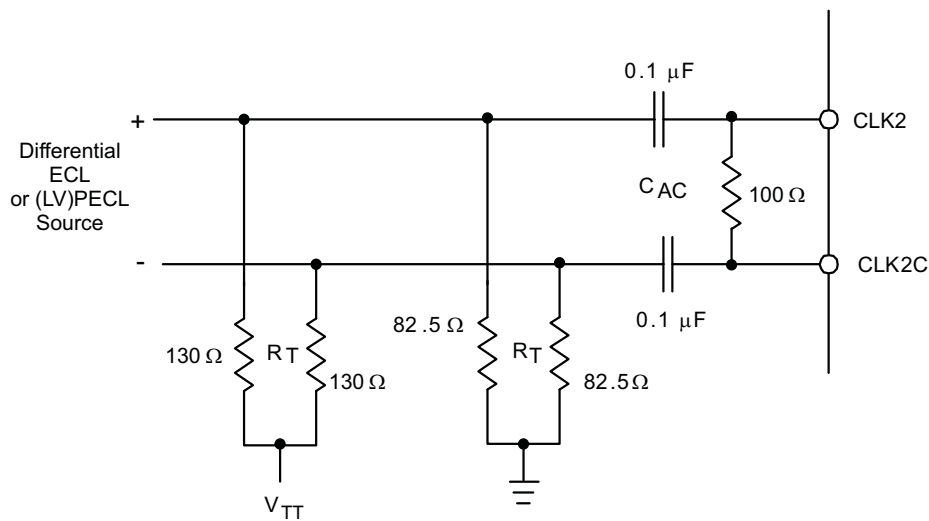

Figure 34. Preferred Clock Input Configuration With a Differential ECL/PECL Clock Source

CLKO_CLK1 and CLK1C Pins

Figure 35 shows the functionality of the CLKO_CLK1 and CLK1C pins. Refer to Table 5. The function of these pins is determined by the CONFIG2 register which is used to select the device clocking mode. In external clock mode (CONFIG2 **dualclk_ena** = '0') both CLKO_CLK1 and CLK1C pins have an internal pull-down resistor approximately equivalent to 100kΩ. CLKO_CLK1 can be set up as an output to drive the data source to the DAC (CONFIG2 **clko_off** = 0).

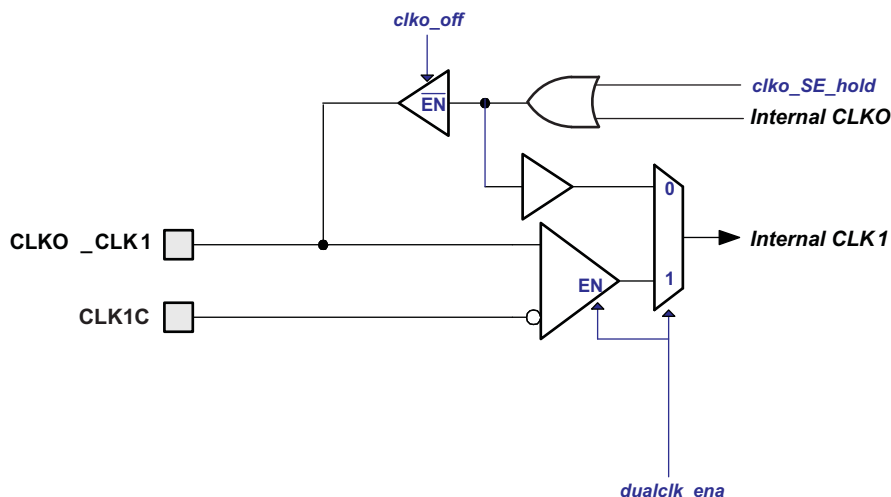

Figure 35. CLKO_CLK1 and CLK1C Pins Control

In dual clock mode (CONFIG2 **dualclk_ena** = '1') the CLKO_CLK1 and CLK1C input pins are configured as a differential CLK1/C clock input. Refer to Figure 36 for the equivalent circuit.

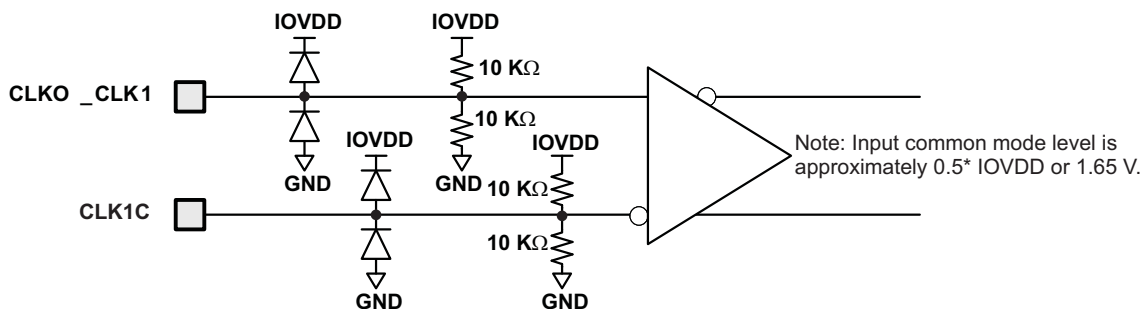

Figure 36. CLKO_CLK1 and CLK1C Dual Clock Mode Equivalent Circuit

Figure 37 shows the preferred configuration for driving CLK1/CLK1C differentially with an ECL/PECL source. Alternatively, CLK1 or CLK1C can be driven single-ended by AC coupling to GND the unused input as shown in Figure 38.

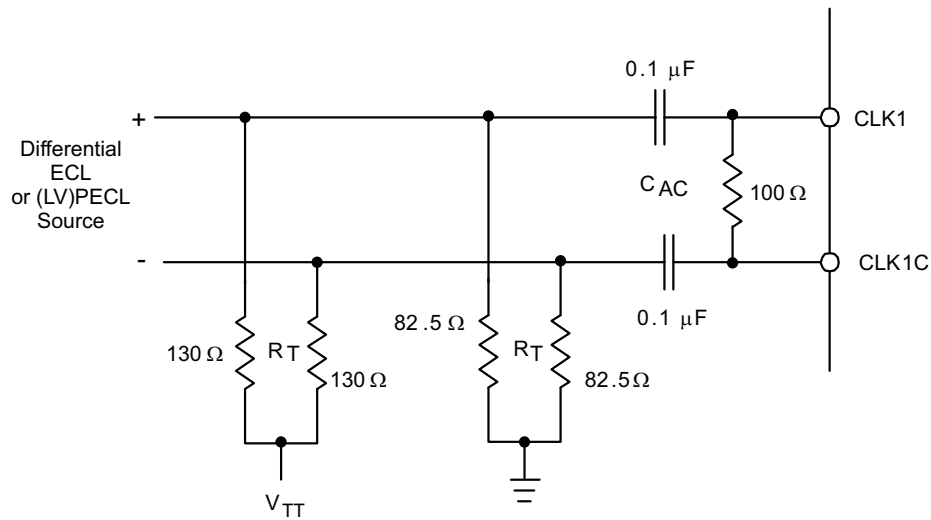

Figure 37. CLK1/CLK1C Input Configuration With a Differential ECL/PECL Clock Source

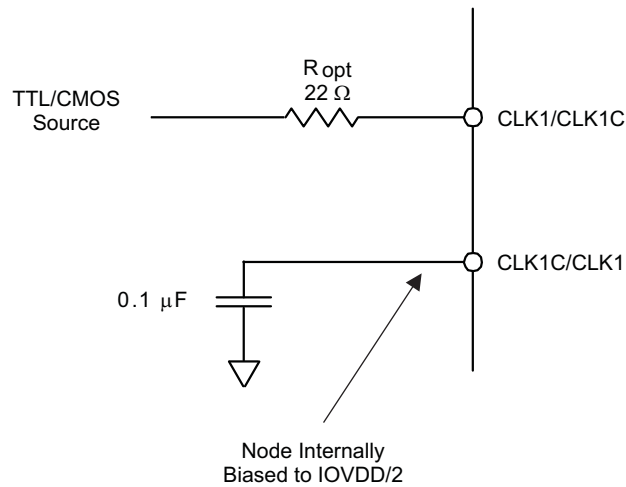

Figure 38. CLK1 or CLK1C Input Configuration with a Single-Ended TTL/CMOS Clock Source

CMOS DIGITAL INPUTS

Figure 39 shows a schematic of the equivalent CMOS digital inputs of the DAC5689. SDIO, SCLK, SYNC, TXENABLE, DA[15:0] and DB[15:0] have pull-down resistors while RESETB and SDENB have pull-up resistors internal the DAC5689. See specification table for logic thresholds. The pull-up and pull-down circuitry is approximately equivalent to 100kΩ.

The input switches levels for all CMOS digital inputs can be changed from 3.3V input levels to 1.8V input levels by programming the CONFIG26 **io_1p8_3p3** register bit. If **io_1p8_3p3** is cleared, the input thresholds are set for 3.3V CMOS levels. If **io_1p8_3p3** is set, the input thresholds are set for 1.8V levels.

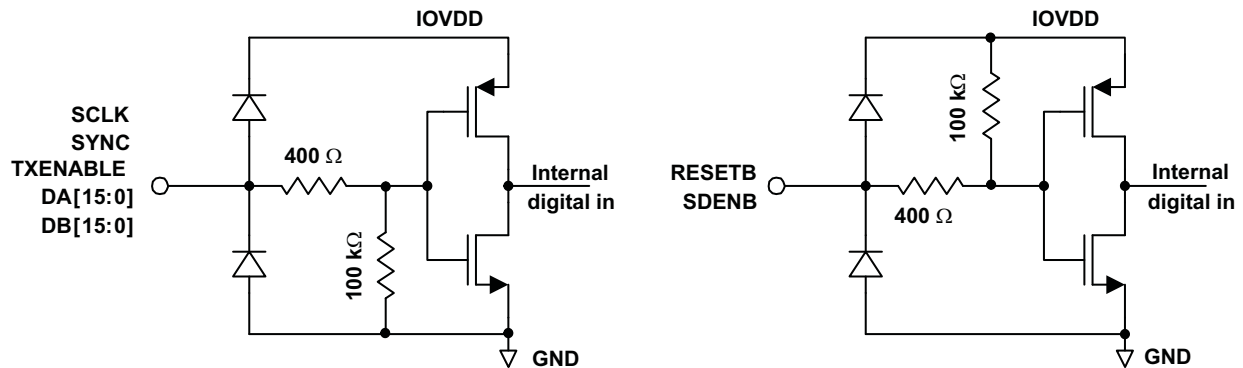

Figure 39. CMOS/TTL Digital Equivalent Input

REFERENCE OPERATION

The DAC5689 uses a bandgap reference and control amplifier for biasing the full-scale output current. The full-scale output current is set by applying an external resistor R_{BIAS} to pin BIASJ. The bias current I_{BIAS} through resistor R_{BIAS} is defined by the on-chip bandgap reference voltage and control amplifier. The default full-scale output current equals 16 times this bias current and can thus be expressed as:

$$I_{OUT_{FS}} = 16 \times I_{BIAS} = 16 \times V_{EXTIO} / R_{BIAS}$$

Each DAC has a 4-bit independent coarse gain control via **coarse_daca(3:0)** and **coarse_dacb (3:0)** in the CONFIG27 register. Using gain control, the $I_{OUT_{FS}}$ can be expressed as:

$$I_{OUTA_{FS}} = (DACA_gain + 1) \times I_{BIAS} = (DACA_gain + 1) \times V_{EXTIO} / R_{BIAS}$$

$$I_{OUTB_{FS}} = (DACB_gain + 1) \times I_{BIAS} = (DACB_gain + 1) \times V_{EXTIO} / R_{BIAS}$$

where V_{EXTIO} is the voltage at terminal EXTIO. The bandgap reference voltage delivers an accurate voltage of 1.2 V. This reference is active when terminal EXTLO is connected to AGND. An external decoupling capacitor C_{EXT} of 0.1 μF should be connected externally to terminal EXTIO for compensation. The bandgap reference can additionally be used for external reference operation. In that case, an external buffer with high impedance input should be applied in order to limit the bandgap load current to a maximum of 100 nA. The internal reference can be disabled and overridden by an external reference by connecting EXTLO to AVDD. Capacitor C_{EXT} may hence be omitted. Terminal EXTIO thus serves as either input or output node.

The full-scale output current can be adjusted from 20 mA down to 2 mA by varying resistor R_{BIAS} or changing the externally applied reference voltage. The internal control amplifier has a wide input range, supporting the full-scale output current range of 20 dB.

DAC TRANSFER FUNCTION

The CMOS DAC's consist of a segmented array of NMOS current sinks, capable of sinking a full-scale output current up to 20 mA. Differential current switches direct the current to either one of the complementary output nodes IOUT1 or IOUT2. ($DACA = IOUTA1$ or $IOUTA2$ and $DACB = IOUTB1$ or $IOUTB2$.) Complementary output currents enable differential operation, thus canceling out common mode noise sources (digital feed-through, on-chip and PCB noise), dc offsets, even order distortion components, and increasing signal output power by a factor of two.

The full-scale output current is set using external resistor R_{BIAS} in combination with an on-chip bandgap voltage reference source (+1.2 V) and control amplifier. Current I_{BIAS} through resistor R_{BIAS} is mirrored internally to provide a maximum full-scale output current equal to 16 times I_{BIAS} .

The relation between I_{OUT1} and I_{OUT2} can be expressed as:

$$I_{OUT1} = -I_{OUT_{FS}} - I_{OUT2}$$

We will denote current flowing into a node as $-$ current and current flowing out of a node as $+$ current. Since the output stage is a current sink the current can only flow from $AVDD$ into the I_{OUT1} and I_{OUT2} pins. The output current flow in each pin driving a resistive load can be expressed as:

$$I_{OUT1} = I_{OUT_{FS}} \times (65536 - \text{CODE}) / 65536$$

$$I_{OUT2} = I_{OUT_{FS}} \times \text{CODE} / 65536$$

where CODE is the decimal representation of the DAC data input word.

For the case where I_{OUT1} and I_{OUT2} drive resistor loads R_L directly, this translates into single ended voltages at I_{OUT1} and I_{OUT2} :

$$V_{OUT1} = AVDD - |I_{OUT1}| \times R_L$$

$$V_{OUT2} = AVDD - |I_{OUT2}| \times R_L$$

Assuming that the data is full scale (65536 in offset binary notation) and the R_L is 25Ω , the differential voltage between pins I_{OUT1} and I_{OUT2} can be expressed as:

$$V_{OUT1} = AVDD - |-0\text{mA}| \times 25 \Omega = 3.3 \text{ V}$$

$$V_{OUT2} = AVDD - |-20\text{mA}| \times 25 \Omega = 2.8 \text{ V}$$

$$V_{DIFF} = V_{OUT1} - V_{OUT2} = 0.5\text{V}$$

Note that care should be taken not to exceed the compliance voltages at node I_{OUT1} and I_{OUT2} , which would lead to increased signal distortion.

DAC OUTPUT SINC RESPONSE

Due to sampled nature of a high-speed DAC's, the well known $\sin(x)/x$ (or SINC) response can significantly attenuate higher frequency output signals. Refer to [Figure 40](#) which shows the unitized SINC attenuation roll-off with respect to the final DAC sample rate in 4 Nyquist zones. For example, if the final DAC sample rate $F_S = 1.0$ GSPS, then a tone at 440MHz will be attenuated by 3.0dB. Although the SINC response can create challenges in frequency planning, one side benefit is the natural attenuation of Nyquist images. The increased over-sampling ratio of the input data provided by the DAC5689's 2x, 4x and 8x digital interpolation modes improve the SINC roll-off (droop) within the original signal's band of interest.

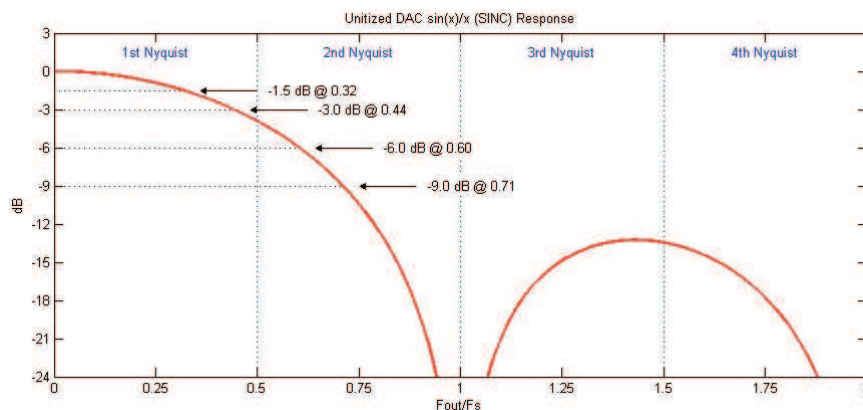

Figure 40. Unitized DAC $\sin(x)/x$ (SINC) Response

ANALOG CURRENT OUTPUTS

Figure 41 shows a simplified schematic of the current source array output with corresponding switches. Differential switches direct the current of each individual NMOS current source to either the positive output node IOU1 or its complementary negative output node IOU2. The output impedance is determined by the stack of the current sources and differential switches, and is typically $>300\text{ k}\Omega$ in parallel with an output capacitance of 5 pF.

The external output resistors are referred to an external ground. The minimum output compliance at nodes IOU1 and IOU2 is limited to $AVDD - 0.5\text{ V}$, determined by the CMOS process. Beyond this value, transistor breakdown may occur resulting in reduced reliability of the DAC5689 device. The maximum output compliance voltage at nodes IOU1 and IOU2 equals $AVDD + 0.5\text{ V}$. Exceeding the minimum output compliance voltage adversely affects distortion performance and integral non-linearity. The optimum distortion performance for a single-ended or differential output is achieved when the maximum full-scale signal at IOU1 and IOU2 does not exceed 0.5 V.

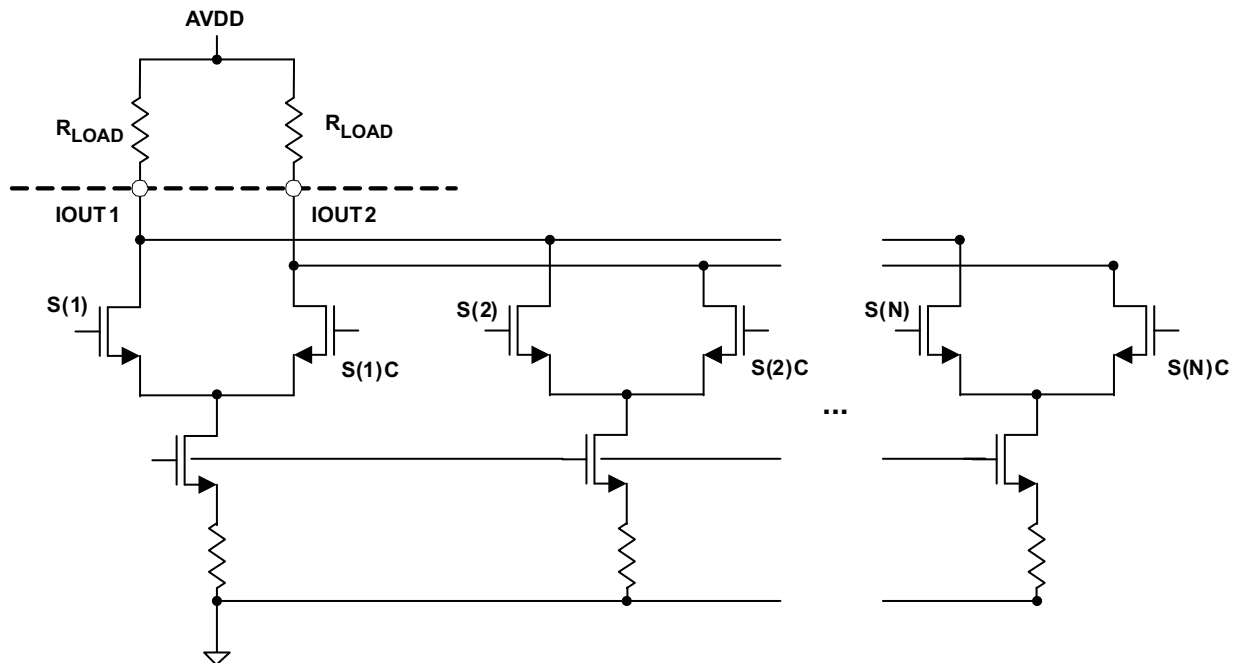

Figure 41. Equivalent Analog Current Output

The DAC5689 can be easily configured to drive a doubly terminated 50Ω cable using a properly selected RF transformer. Figure 42 and Figure 43 show the 50Ω doubly terminated transformer configuration with 1:1 and 4:1 impedance ratio, respectively. Note that the center tap of the primary input of the transformer has to be connected to AVDD to enable a dc current flow. Applying a 20mA full-scale output current would lead to a 0.5 V_{PP} for a 1:1 transformer and a 1 V_{PP} output for a 4:1 transformer. The low dc-impedance between IOU1 or IOU2 and the transformer center tap sets the center of the ac-signal at AVDD, so the 1 V_{PP} output for the 4:1 transformer results in an output between $AVDD + 0.5\text{ V}$ and $AVDD - 0.5\text{ V}$.

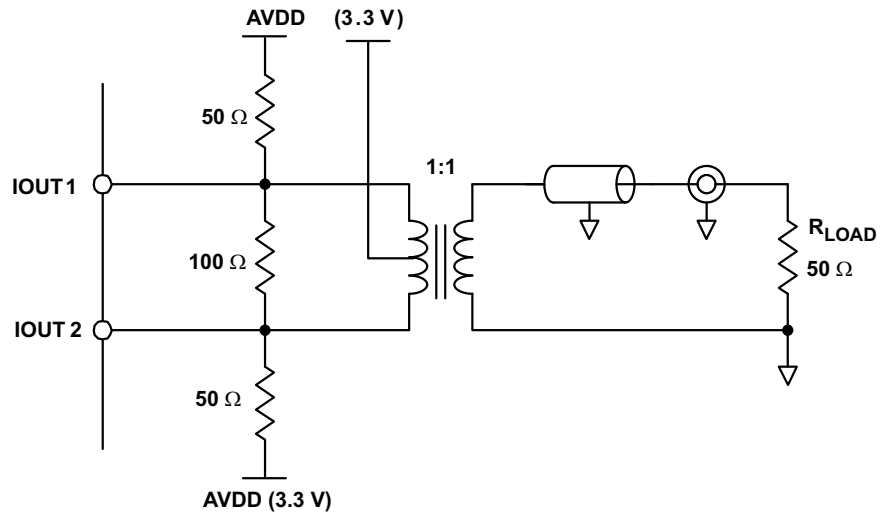

Figure 42. Driving a Doubly Terminated 50Ω Cable Using a 1:1 Impedance Ratio Transformer

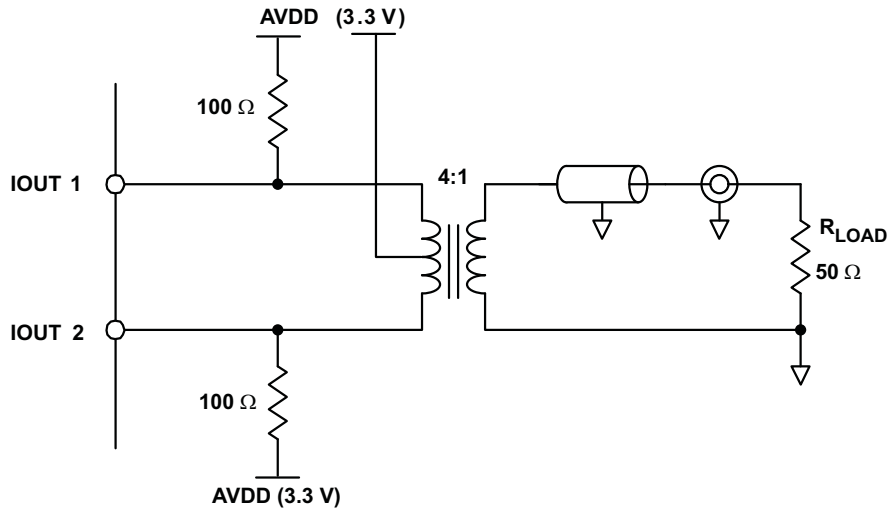

Figure 43. Driving a Doubly Terminated 50Ω Cable Using a 4:1 Impedance Ratio Transformer

RECOMMENDED STARTUP SEQUENCE

The following startup sequence is recommend to initialization the DAC5689:

1. Supply all 1.8V (CLKVDD, DVDD, VFUSE) and 3.3V (AVDD and IOVDD) voltages.
2. Toggle RESETB pin for a minimum 25 nSec active low pulse width.
3. Provide a stable CLK2/C input clock.
4. Program all desired SIF registers. **Bits [1:0] in register CONFIG26 must be set to "10" for proper operation.** Please note these are not the default values after resetting the device.
5. Provide a sync signal to all digital blocks. The sync input source may be either TXENABLE pin, SYNC pin or a software sync via CONFIG5 **sif_sync_sig** bit; however, only the TXENABLE or SYNC pins are recommended for multi-DAC synchronization. Refer to CONFIG5, CONFIG22 and CONFIG23 registers for sync source selection. Note: Registers CONFIG6 through CONFIG13 all require a sync input to transfer the contents of the control register inputs to the active digital blocks.
6. Provide data flow.

MULTI-DAC SYNCHRONIZATION

If the system has two or more DACs requiring synchronization, the sync signal in Step 5 of the RECOMMENDED STARTUP SEQUENCE must be provided to all the DACs simultaneously. The sync input source must be either the TXENABLE pin or the SYNC pin (the software sync is not recommended).

In some applications such as beamforming it is required that the multiple DACs in the system have constant latency thus resulting in phase aligned outputs. As a result of the clock domain transfer on the DAC5689 FIFO, the outputs of all DACs can only be synchronized to within ± 1 DAC clock cycle in the External and Dual Clock modes. In order to ensure exact phase alignment between all devices it is required to set up the device in Dual Synchronous Clock mode.

PACKAGING INFORMATION

Orderable Device	Status ⁽¹⁾	Package Type	Package Drawing	Pins	Package Qty	Eco Plan ⁽²⁾	Lead/Ball Finish	MSL Peak Temp ⁽³⁾
DAC5689IRGCR	ACTIVE	VQFN	RGC	64	2000	Green (RoHS & no Sb/Br)	CU NIPDAU	Level-3-260C-168 HR
DAC5689IRGCT	ACTIVE	VQFN	RGC	64	250	Green (RoHS & no Sb/Br)	CU NIPDAU	Level-3-260C-168 HR

⁽¹⁾ The marketing status values are defined as follows:

ACTIVE: Product device recommended for new designs.

LIFEBUY: TI has announced that the device will be discontinued, and a lifetime-buy period is in effect.

NRND: Not recommended for new designs. Device is in production to support existing customers, but TI does not recommend using this part in a new design.

PREVIEW: Device has been announced but is not in production. Samples may or may not be available.

OBsolete: TI has discontinued the production of the device.

⁽²⁾ Eco Plan - The planned eco-friendly classification: Pb-Free (RoHS), Pb-Free (RoHS Exempt), or Green (RoHS & no Sb/Br) - please check <http://www.ti.com/productcontent> for the latest availability information and additional product content details.

TBD: The Pb-Free/Green conversion plan has not been defined.

Pb-Free (RoHS): TI's terms "Lead-Free" or "Pb-Free" mean semiconductor products that are compatible with the current RoHS requirements for all 6 substances, including the requirement that lead not exceed 0.1% by weight in homogeneous materials. Where designed to be soldered at high temperatures, TI Pb-Free products are suitable for use in specified lead-free processes.

Pb-Free (RoHS Exempt): This component has a RoHS exemption for either 1) lead-based flip-chip solder bumps used between the die and package, or 2) lead-based die adhesive used between the die and leadframe. The component is otherwise considered Pb-Free (RoHS compatible) as defined above.

Green (RoHS & no Sb/Br): TI defines "Green" to mean Pb-Free (RoHS compatible), and free of Bromine (Br) and Antimony (Sb) based flame retardants (Br or Sb do not exceed 0.1% by weight in homogeneous material)

⁽³⁾ MSL, Peak Temp. -- The Moisture Sensitivity Level rating according to the JEDEC industry standard classifications, and peak solder temperature.

Important Information and Disclaimer:The information provided on this page represents TI's knowledge and belief as of the date that it is provided. TI bases its knowledge and belief on information provided by third parties, and makes no representation or warranty as to the accuracy of such information. Efforts are underway to better integrate information from third parties. TI has taken and continues to take reasonable steps to provide representative and accurate information but may not have conducted destructive testing or chemical analysis on incoming materials and chemicals. TI and TI suppliers consider certain information to be proprietary, and thus CAS numbers and other limited information may not be available for release.

In no event shall TI's liability arising out of such information exceed the total purchase price of the TI part(s) at issue in this document sold by TI to Customer on an annual basis.

TAPE AND REEL INFORMATION

QUADRANT ASSIGNMENTS FOR PIN 1 ORIENTATION IN TAPE

*All dimensions are nominal

Device	Package Type	Package Drawing	Pins	SPQ	Reel Diameter (mm)	Reel Width W1 (mm)	A0 (mm)	B0 (mm)	K0 (mm)	P1 (mm)	W (mm)	Pin1 Quadrant
DAC5689IRGCR	VQFN	RGC	64	2000	330.0	16.4	9.3	9.3	1.5	12.0	16.0	Q2
DAC5689IRGCT	VQFN	RGC	64	250	330.0	16.4	9.3	9.3	1.5	12.0	16.0	Q2

TAPE AND REEL BOX DIMENSIONS

*All dimensions are nominal

Device	Package Type	Package Drawing	Pins	SPQ	Length (mm)	Width (mm)	Height (mm)
DAC5689IRGCR	VQFN	RGC	64	2000	333.2	345.9	28.6
DAC5689IRGCT	VQFN	RGC	64	250	333.2	345.9	28.6

RGC (S-PQFP-N64) CUSTOM DEVICE PLASTIC QUAD FLATPACK

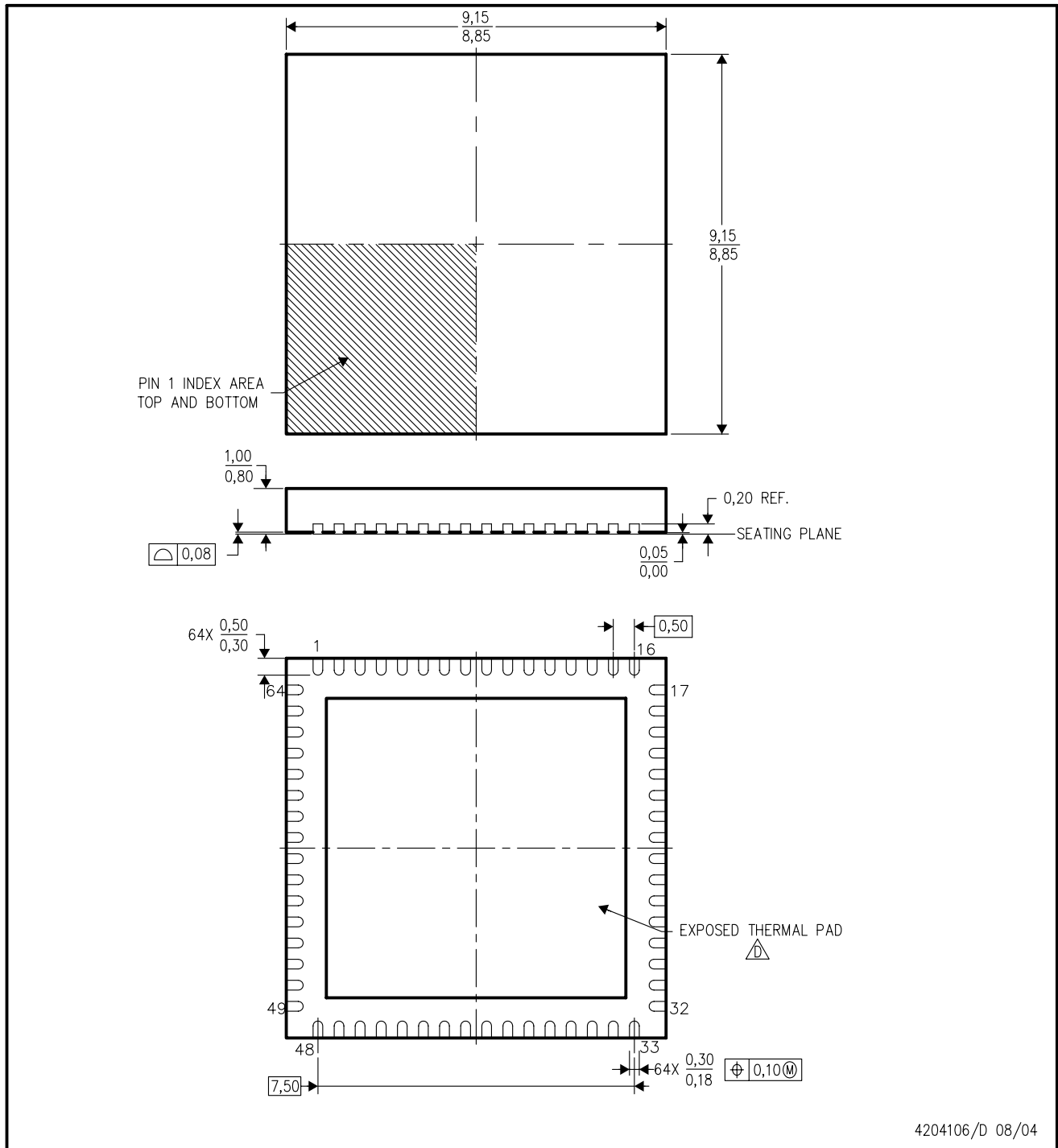

- NOTES:
- A. All linear dimensions are in millimeters. Dimensioning and tolerancing per ASME Y14.5-1994.
 - B. This drawing is subject to change without notice.
 - C. Quad Flatpack, No-leads (QFN) package configuration .
-  The package thermal pad must be soldered to the board for thermal and mechanical performance. See the Product Data Sheet for details regarding the exposed thermal pad dimensions.

THERMAL INFORMATION

This package incorporates an exposed thermal pad that is designed to be attached directly to an external heatsink. The thermal pad must be soldered directly to the printed circuit board (PCB). After soldering, the PCB can be used as a heatsink. In addition, through the use of thermal vias, the thermal pad can be attached directly to the appropriate copper plane shown in the electrical schematic for the device, or alternatively, can be attached to a special heatsink structure designed into the PCB. This design optimizes the heat transfer from the integrated circuit (IC).

For information on the Quad Flatpack No-Lead (QFN) package and its advantages, refer to Application Report, QFN/SON PCB Attachment, Texas Instruments Literature No. SLUA271. This document is available at www.ti.com.

The exposed thermal pad dimensions for this package are shown in the following illustration.

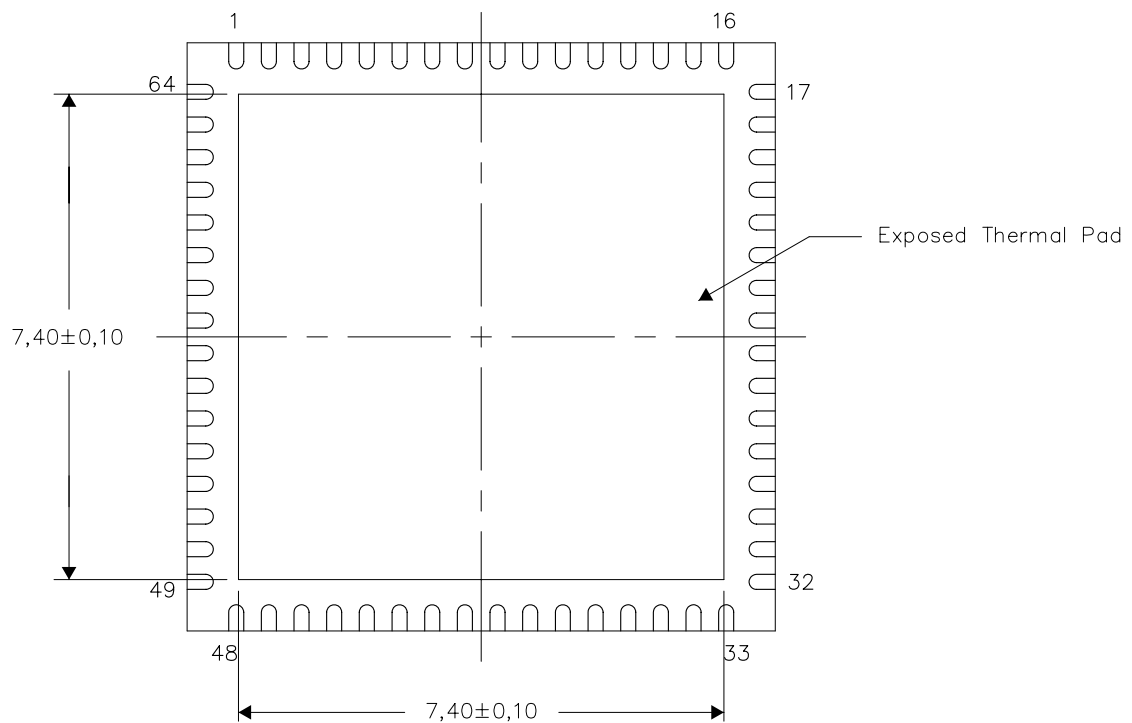

Bottom View

NOTE: All linear dimensions are in millimeters

Exposed Thermal Pad Dimensions

RGC (S-PVQFN-N64)

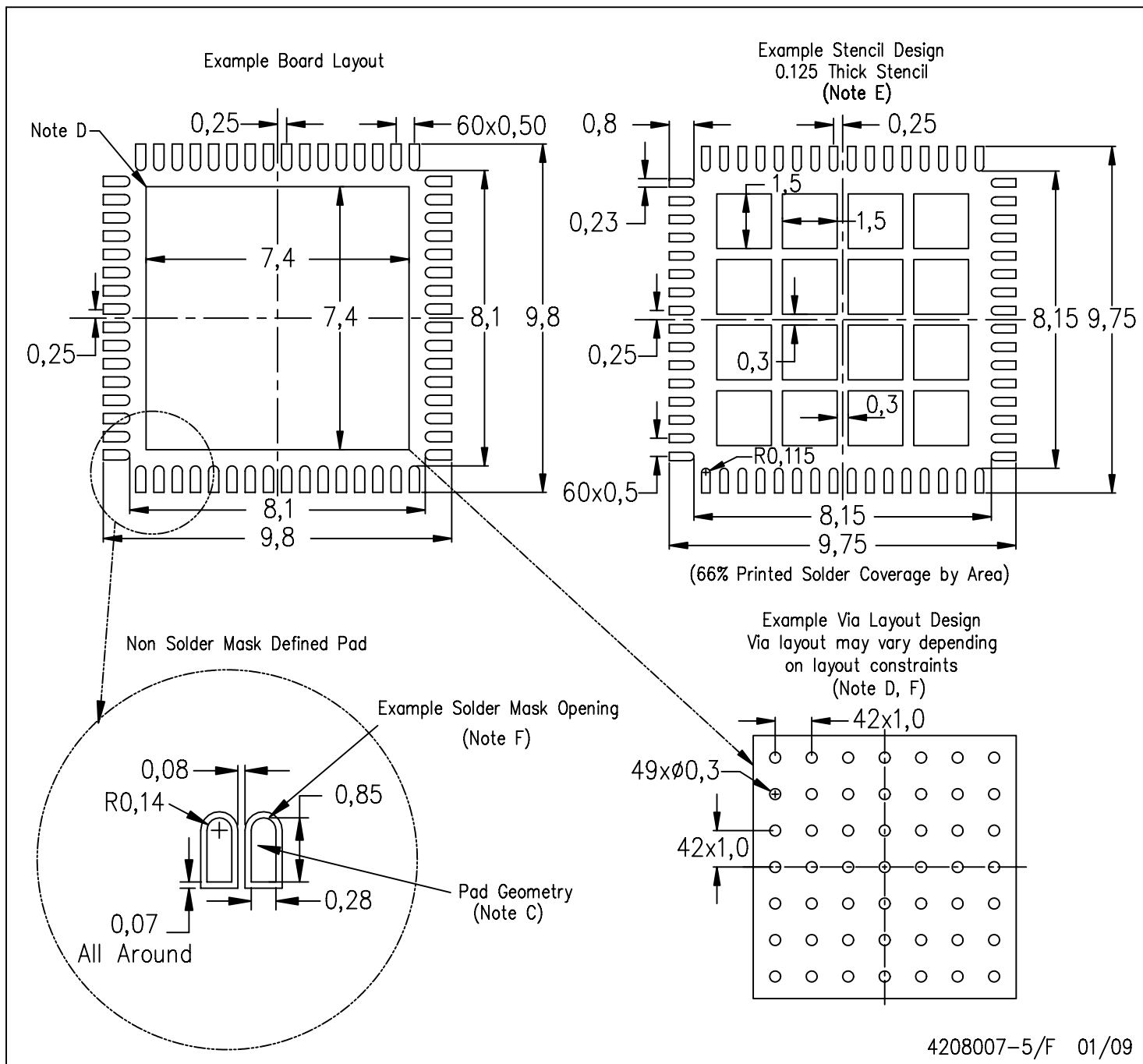

- NOTES:
- All linear dimensions are in millimeters.
 - This drawing is subject to change without notice.
 - Publication IPC-7351 is recommended for alternate designs.
 - This package is designed to be soldered to a thermal pad on the board. Refer to Application Note, Quad Flat-Pack Packages, Texas Instruments Literature No. SLUA271, and also the Product Data Sheets for specific thermal information, via requirements, and recommended board layout. These documents are available at www.ti.com <<http://www.ti.com>>.
 - Laser cutting apertures with trapezoidal walls and also rounding corners will offer better paste release. Customers should contact their board assembly site for stencil design recommendations. Refer to IPC 7525 for stencil design considerations.
 - Customers should contact their board fabrication site for recommended solder mask tolerances and via tenting recommendations for vias placed in thermal pad.

IMPORTANT NOTICE

Texas Instruments Incorporated and its subsidiaries (TI) reserve the right to make corrections, modifications, enhancements, improvements, and other changes to its products and services at any time and to discontinue any product or service without notice. Customers should obtain the latest relevant information before placing orders and should verify that such information is current and complete. All products are sold subject to TI's terms and conditions of sale supplied at the time of order acknowledgment.

TI warrants performance of its hardware products to the specifications applicable at the time of sale in accordance with TI's standard warranty. Testing and other quality control techniques are used to the extent TI deems necessary to support this warranty. Except where mandated by government requirements, testing of all parameters of each product is not necessarily performed.

TI assumes no liability for applications assistance or customer product design. Customers are responsible for their products and applications using TI components. To minimize the risks associated with customer products and applications, customers should provide adequate design and operating safeguards.

TI does not warrant or represent that any license, either express or implied, is granted under any TI patent right, copyright, mask work right, or other TI intellectual property right relating to any combination, machine, or process in which TI products or services are used. Information published by TI regarding third-party products or services does not constitute a license from TI to use such products or services or a warranty or endorsement thereof. Use of such information may require a license from a third party under the patents or other intellectual property of the third party, or a license from TI under the patents or other intellectual property of TI.

Reproduction of TI information in TI data books or data sheets is permissible only if reproduction is without alteration and is accompanied by all associated warranties, conditions, limitations, and notices. Reproduction of this information with alteration is an unfair and deceptive business practice. TI is not responsible or liable for such altered documentation. Information of third parties may be subject to additional restrictions.

Resale of TI products or services with statements different from or beyond the parameters stated by TI for that product or service voids all express and any implied warranties for the associated TI product or service and is an unfair and deceptive business practice. TI is not responsible or liable for any such statements.

TI products are not authorized for use in safety-critical applications (such as life support) where a failure of the TI product would reasonably be expected to cause severe personal injury or death, unless officers of the parties have executed an agreement specifically governing such use. Buyers represent that they have all necessary expertise in the safety and regulatory ramifications of their applications, and acknowledge and agree that they are solely responsible for all legal, regulatory and safety-related requirements concerning their products and any use of TI products in such safety-critical applications, notwithstanding any applications-related information or support that may be provided by TI. Further, Buyers must fully indemnify TI and its representatives against any damages arising out of the use of TI products in such safety-critical applications.

TI products are neither designed nor intended for use in military/aerospace applications or environments unless the TI products are specifically designated by TI as military-grade or "enhanced plastic." Only products designated by TI as military-grade meet military specifications. Buyers acknowledge and agree that any such use of TI products which TI has not designated as military-grade is solely at the Buyer's risk, and that they are solely responsible for compliance with all legal and regulatory requirements in connection with such use.

TI products are neither designed nor intended for use in automotive applications or environments unless the specific TI products are designated by TI as compliant with ISO/TS 16949 requirements. Buyers acknowledge and agree that, if they use any non-designated products in automotive applications, TI will not be responsible for any failure to meet such requirements.

Following are URLs where you can obtain information on other Texas Instruments products and application solutions:

Products

Amplifiers	amplifier.ti.com
Data Converters	dataconverter.ti.com
DLP® Products	www.dlp.com
DSP	dsp.ti.com
Clocks and Timers	www.ti.com/clocks
Interface	interface.ti.com
Logic	logic.ti.com
Power Mgmt	power.ti.com
Microcontrollers	microcontroller.ti.com
RFID	www.ti-rfid.com
RF/IF and ZigBee® Solutions	www.ti.com/lprf

Applications

Audio	www.ti.com/audio
Automotive	www.ti.com/automotive
Broadband	www.ti.com/broadband
Digital Control	www.ti.com/digitalcontrol
Medical	www.ti.com/medical
Military	www.ti.com/military
Optical Networking	www.ti.com/opticalnetwork
Security	www.ti.com/security
Telephony	www.ti.com/telephony
Video & Imaging	www.ti.com/video
Wireless	www.ti.com/wireless

Mailing Address: Texas Instruments, Post Office Box 655303, Dallas, Texas 75265
Copyright © 2009, Texas Instruments Incorporated