

# HCPL-T251

## 0.4 Amp Output Current IGBT Gate Drive Optocoupler



### Data Sheet



#### Description

The HCPL-T251 contains GaAsP LED. The LED is optically coupled to an integrated circuit with a power output stage. This optocoupler is ideally suited for driving power IGBTs and MOSFETs used in motor control inverter applications. The high operating voltage range of the output stage provides the drive voltages required by gate controlled devices. The voltage and current supplied by this optocoupler makes it ideally suited for directly driving small or medium power IGBTs.

#### Functional Diagram

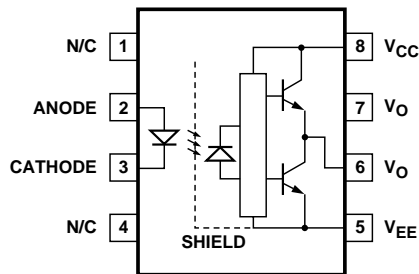

A 0.1 μF bypass capacitor must be connected between pins 5 and 8.

#### Truth Table

LED	V <sub>out</sub>
OFF	LOW
ON	HIGH

#### Features

- Supply current (I<sub>CC</sub>): 11 mA (max.)
- Supply voltage (V<sub>CC</sub>): 10-30 V
- Output current (I<sub>O</sub>): ±0.4 A (min.)
- Switching time (t<sub>PLH</sub>/t<sub>PHL</sub>): 1 μs (max.)
- Isolation voltage (V<sub>ISO</sub>): 3750 Vrms (min.)
- UL 577 Recognized: File No. E55361
- CSA Approved
- 10 kV/μs Minimum Common Mode Rejection (CMR) at V<sub>cm</sub> = 600 V
- Creepage distance: 7.4 mm  
Clearance: 7.1 mm

#### Applications

- IGBT/MOSFET gate drive
- AC/brushless DC motor drives
- Industrial inverters
- Switch mode power supplies

**CAUTION:** It is advised that normal static precautions be taken in handling and assembly of this component to prevent damage and/or degradation which may be induced by ESD.

## HCPL-T251

HCPL-T251 is UL Recognized with 3750 Vrms for 1 minute per UL1577.

Part Number	Option		Package	Surface Mount	Gull Wing	Tape & Reel	Quantity
	RoHS Compliant	Non RoHS Compliant					
HCPL-T251	-000E	No option	300mil DIP-8				50 per tube
	-300E	#300		X	X		50 per tube
	-500E	#500		X	X	X	1000 per reel

To order, choose a part number from the part number column and combine with the desired option from the option column to form an order entry.

### Example 1:

HCPL-T251-500E to order product of 300 mil DIP Gull Wing Surface Mount package in Tape and Reel and RoHS compliant.

### Example 2:

HCPL-T251 to order product of 300 mil DIP package in tube packaging and non RoHS compliant.

Option datasheets are available. Contact your Avago sales representative or authorized distributor for information.

Remarks: The notation '#XXX' is used for existing products, while (new) products launched since 15<sup>th</sup> July 2001 and RoHS compliant option will use '-XXxE'.

Package Outline Drawings  
Standard DIP Package

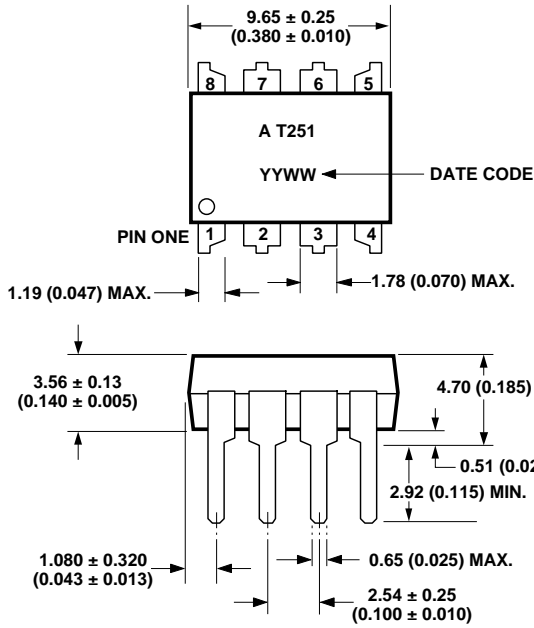

DIMENSIONS IN MILLIMETERS AND (INCHES).

NOTE: FLOATING LEAD PROTRUSION IS 0.25 mm (10 mils) MAX.

Gull Wing Surface Mount Option 300

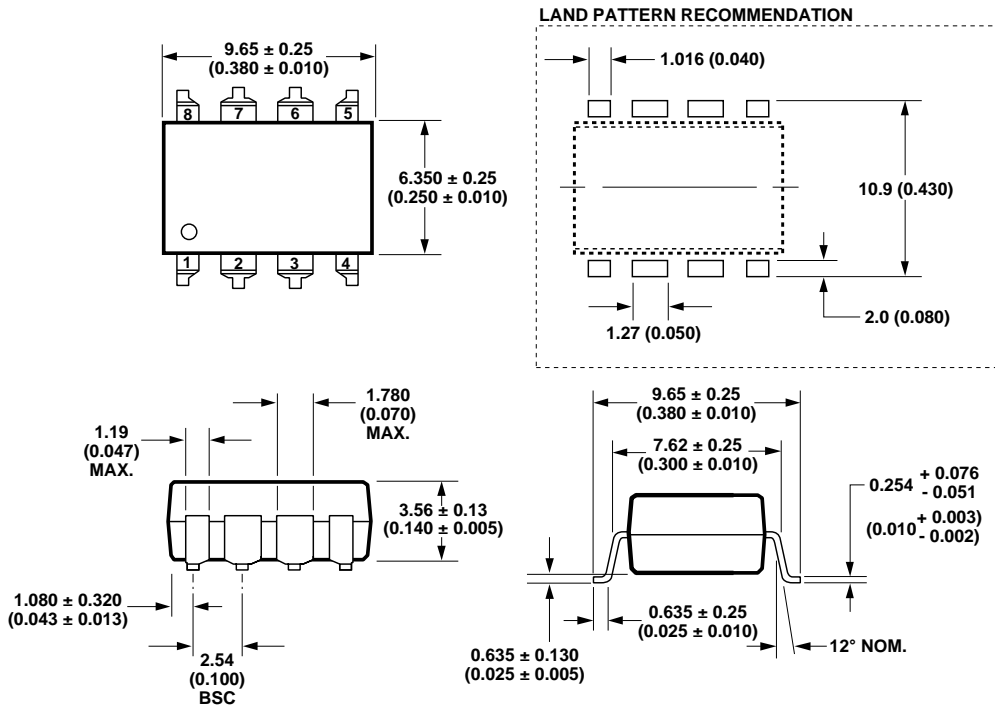

DIMENSIONS IN MILLIMETERS (INCHES).  
LEAD COPLANARITY = 0.10 mm (0.004 INCHES).

NOTE: FLOATING LEAD PROTRUSION IS 0.25 mm (10 mils) MAX.

**Regulatory Information**

The HCPL-T251 is under approval by the following organizations:

**UL**

Approval under UL 1577, Component Recognition Program, File E55361.

**CSA**

Approval under CSA Component Acceptance Notice #5, File CA 88324.

**Insulation and Safety Related**

Parameter	Symbol	Value	Units	Conditions
Minimum External Air Gap (Clearance)	L(101)	7.1	mm	Measured from input terminals to output terminals, shortest distance through air.
Minimum External Tracking (Creepage)	L(102)	7.4	mm	Measured from input terminals to output terminals, shortest distance path along body.
Minimum Internal Plastic Gap (Internal Clearance)		0.08	mm	Insulation thickness between emitter and detector; also known as distance through insulation
Tracking Resistance (Comparative Tracking Index)	CTI	≥175	Volts	DIN IEC 112/VDE 0303 Part 1
Isolation Group		IIIa		Material Group (DIN VDE 0110, 1/89, Table 1)

**Absolute Maximum Ratings** (Compared with HCPL-3140)

Parameter	Symbol	Units	HCPL-3140		HCPL-T251		Note
			Min.	Max.	Min.	Max.	
Operating Temperature	$T_A$	°C	-40	100	-20	85	
"High" Peak Output Current	$I_{OH(PEAK)}$	A		0.6		0.4	1
"High" Peak Output Current	$I_{OL(PEAK)}$	A		0.6		0.4	
Storage Temperature	$T_S$	°C	-55	125	-55	125	
Average Input Current	$I_{F(AVG)}$	mA		25		20	2
Peak Transient Input Current (<1 μs Pulse Width, 300 pps)	$I_{F(TRAN)}$	A		1.0		1.0	
Reverse Input Voltage	$V_R$	V		5		5	
Supply Voltage	$(V_{CC} - V_{EE})$	V	-0.5	35	-0.5	35	
Output Voltage	$V_O$	V	0	$V_{CC}$	0	$V_{CC}$	
Output Power Dissipation	$P_O$	mW		250		250	3
Lead Solder Temperature	260°C for 10 sec., 1.6 mm below seating plane						
Solder Reflow Temperature Profile	See <b>Package Outline Drawings</b> section						

**Notes:**

1. Maximum pulse width = 10 μs, maximum duty cycle = 0.2%.
2. Derate linearly above 70°C free-air temperature at a rate of 0.3 mA/°C.
3. Derate linearly above 70°C free-air temperature at a rate of 4.8 mW/°C.

## Recommended Operating Conditions

Parameter	Symbol	Min.	Max.	Units
Power Supply Voltage	$V_{CC} - V_{EE}$	15	30	V
Input Current (ON)	$I_{F(ON)}$	8	12	mA
Input Voltage (OFF)	$V_{F(OFF)}$	0	0.8	V

## DC Electrical Specifications (Compared with HCPL-3140)

Over recommended operating conditions ( $I_{F(ON)} = 8$  to  $12$  mA,  $V_{F(OFF)} = 0$  to  $0.8$  V,  $V_{CC} = 15$  to  $30$  V,  $V_{EE} = \text{Ground}$ ) unless otherwise specified.

Parameter	Symbol	Units	HCPL-3140			HCPL-T251			Test Conditions	Note
			Min.	Typ.*	Max.	Min.	Typ.*	Max.		
Input Forward Voltage	$V_F$	V	1.2	1.5	1.8		1.6	1.8	$I_F = 10$ mA	
Temperature Coefficient of Forward Voltage	$\Delta V_F / \Delta T_A$	mV/°C		-1.6			-2.0		$I_F = 10$ mA	
Input Reverse Current	$I_R$	$\mu\text{A}$			10			10	$V_R = 5$ V	
Input Capacitance	$C_{IN}$	pF		60			45	250	$V_F = 0$ V, $F = 1$ MHz	
High Level Output Current	$I_{OH}$	A	0.2				0.25		$V_O = V_{CC} - 4$ V	
			0.4	0.5		N.A.		$V_O = V_{CC} - 15$ V		
Low Level Output Current	$I_{OL}$	A	0.2	0.4		0.1	0.2		$V_O = V_{CC} - 4$ V	
			0.4	0.5		N.A.		$V_O = V_{CC} - 15$ V		
High Level Output Voltage	$V_{OH}$	V	$V_{CC} - 4$	$V_{CC} - 1.8$		$V_{CC} - 4$	$V_{CC} - 1.8$		$I_O = -100$ mA	
Low Level Output Voltage	$V_{OL}$	V		0.4	1		0.5		$I_O = 100$ mA	
High Level Supply Current	$I_{CCH}$	mA		0.7	3		7.5	11	Output Open $I_F = 7$ to $16$ mA	
Low Level Supply Current	$I_{CCL}$	mA		1 - 2	3		8	11	Output Open $V_F = -3.0$ to $+0.8$ V	
Threshold Input Current Low to High	$I_{FLH}$	mA			6			7	$I_O = 0$ mA, $V_O > 5$ V	
Threshold Input Voltage High to Low	$V_{FHL}$	V	0.8			0.8				
Supply Voltage	$V_{CC}$	V	10		30	10		30		
Capacitance (Input-Output)	$C_{I-O}$	pF		60			60			
Resistance (Input-Output)	$R_{I-O}$	$\Omega$		$10^{12}$			$10^{12}$			

\*All typical values at  $T_A = 25^\circ\text{C}$  and  $V_{CC} - V_{EE} = 3^\circ\text{V}$ , unless otherwise noted.

**Switching Specifications (AC)** (Compared with HCPL-3140)

Over recommended operating conditions ( $T_A = -40$  to  $100^\circ\text{C}$ ,  $I_{F(\text{ON})} = 8$  to  $12$  mA,  $V_{F(\text{OFF})} = -3.0$  to  $0.8$  V,  $V_{CC} = 15$  to  $30$  V,  $V_{EE} = \text{Ground}$ ) unless otherwise specified.

Parameter	Symbol	Units	HCPL-3140 ( $-40^\circ\text{C} \sim 100^\circ\text{C}$ )			HCPL-T251 ( $-20^\circ\text{C} \sim 70^\circ\text{C}$ )			Test Conditions	Note	
			Min.	Typ.*	Max.	Min.	Typ.*	Max.			
Propagation Delay Time to High Output Level	$t_{\text{PHL}}$	$\mu\text{s}$	0.1	0.2	0.7		0.25	1	$R_g = 47 \Omega$ $C_g = 3 \text{ nF}$ , $f = 10 \text{ kHz}$ , Duty Cycle = 50%		
Propagation Delay Time to Low Output Level	$T_{\text{PLH}}$	$\mu\text{s}$	0.1	0.3	0.7		0.25	1			
Output Rise Time	$t_R$	ns		50		N.A.					
Output Fall Time	$t_F$	ns		50		N.A.					
Propagation Delay Difference Between Any Two Parts	$(t_{\text{PHL}} - t_{\text{PLH}})$ PDD	$\mu\text{s}$	-0.5		0.5	N.A.		N.A.		4	
Output High Level Common Mode Transient Immunity	$ CM_H $	kV/ $\mu\text{s}$	10			10			$T_A = 25^\circ\text{C}$ $V_{CC} = 30 \text{ V}$	5	
									HCPL-3140		$I_F = 10 \text{ mA}$ $V_{CM} = 1000 \text{ V}$
									HCPL-T251		$I_F = 8 \text{ mA}$ $V_{CM} = 600 \text{ V}$
Output Low Level Common Mode Transient Immunity	$ CM_L $	kV/ $\mu\text{s}$	10			10			$T_A = 25^\circ\text{C}$ $V_F = 0 \text{ V}$	5	
									HCPL-3140		$V_{CM} = 1000 \text{ V}$
									HCPL-T251		$V_{CM} = 600 \text{ V}$

\*All typical values at  $T_A = 25^\circ\text{C}$  and  $V_{CC} - V_{EE} = 30 \text{ V}$ , unless otherwise noted.

**Notes:**

- The difference between  $t_{\text{PHL}}$  and  $t_{\text{PLH}}$  between any two HCPL-3140 parts under the same test condition.
- Common mode transient immunity in the high state is the maximum tolerable  $dV_{CM}/dt$  of the common mode pulse,  $V_{CM}$ , to assure that the output will remain in the high state (i.e.,  $V_O > 15.0 \text{ V}$ ).
- Common mode transient immunity in a low state is the maximum tolerable  $dV_{CM}/dt$  of the common mode pulse,  $V_{CM}$ , to assure that the output will remain in a low state (i.e.,  $V_O < 1.0 \text{ V}$ ).

For product information and a complete list of distributors, please go to our website: [www.avagotech.com](http://www.avagotech.com)

Avago, Avago Technologies, and the A logo are trademarks of Avago Technologies Limited in the United States and other countries.  
Data subject to change. Copyright © 2007 Avago Technologies Limited. All rights reserved. Obsoletes 5989-0285EN  
AV01-0533EN June 19, 2007

