

**±15kV ESD Protected, 10nA Supply-Current, +3V to +5.5V, 250k/1Mbps, RS-232 Transmitters/Receivers**

The Intersil ICL3237E contains 3.0V to 5.5V powered RS-232 transmitters/receivers which meet EIA/TIA-232 and V.28/V.24 specifications, even at  $V_{CC} = 3.0V$ . Additionally, it provides ±15kV ESD protection (IEC61000-4-2 Air Gap and Human Body Model) on transmitter outputs and receiver inputs (RS-232 pins). Targeted applications are cell phones, PDAs, Palmtops, and notebook and laptop computers where the low operational, and even lower standby, power consumption is critical. Efficient on-chip charge pumps, coupled with the manual powerdown function, reduce the standby supply current to a 10nA trickle. Small footprint packaging, and the use of small, low value capacitors ensure board space savings as well. Data rates greater than 1Mbps ( $MBAUD = V_{CC}$ ) are guaranteed at worst case load conditions. The ICL3237E is fully compatible with 3.3V only systems, mixed 3.3V and 5.0V systems, and 5.0V only systems.

The ICL3237E is a 5 driver, 3 receiver device that also includes a noninverting always-active receiver for “wake-up” capability.

Table 1 summarizes the features of the device represented by this data sheet, while Application Note AN9863 summarizes the features of each device comprising the ICL32XX 3V family.

**Features**

- ESD Protection For RS-232 I/O Pins to ±15kV (IEC61000)
- Pin Compatible Replacement for MAX3237E
- Pin Selectable, Guaranteed Data Rate . . . 250kpbs/1Mbps
- Meets EIA/TIA-232 and V.28/V.24 Specifications at 3V
- RS-232 Compatible with  $V_{CC} = 2.7V$
- Latch-Up Free
- On-Chip Voltage Converters Require Only Four External Capacitors
- Manual Powerdown Feature
- Flow Through Pinout
- Rx and Tx Hysteresis For Improved Noise Immunity
- Rx Active in Powerdown; Separate Rx Enable Pin
- Guaranteed Minimum Slew Rate . . . . . 6V/μs or 24V/μs
- Wide Power Supply Range. . . . . Single +3V to +5.5V
- Low Supply Current in Powerdown State. . . . . 10nA
- Pb-free available

**Applications**

- Any System Requiring RS-232 Communication Ports
  - Battery Powered, Hand-Held, and Portable Equipment
  - Laptop Computers, Notebooks, Palmtops
  - Modems, Printers and other Peripherals
  - Data Cradles and Cables
  - Cellular/Mobile Phone

**TABLE 1. SUMMARY OF FEATURES**

PART NUMBER	NO. OF Tx.	NO. OF Rx.	NO. OF MONITOR Rx. (ROUTB)	(NOTE 1) DATA RATE (kbps)	Rx. ENABLE FUNCTION?	READY OUTPUT?	MANUAL POWER-DOWN?	AUTOMATIC POWERDOWN FUNCTION?
ICL3237E	5	3	1	250/1000	YES	NO	YES	NO

NOTE:

1. Data rate is selectable via the MBAUD pin.

Pinout

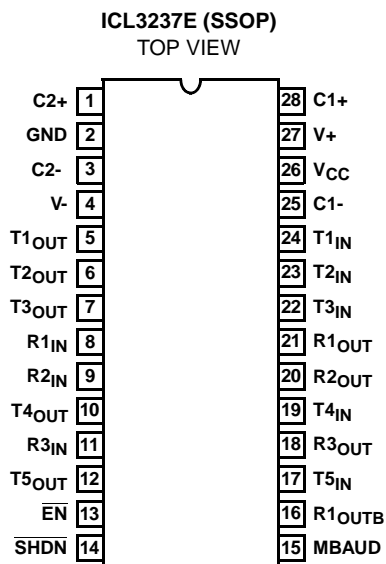

Ordering Information

PART NUMBER	TEMP. RANGE (°C)	PACKAGE	PKG. DWG. #
ICL3237ECA	0 to 70	28 Ld SSOP	M28.209
ICL3237ECAZ (See Note)	0 to 70	28 Ld SSOP (Pb-free)	M28.209
ICL3237EIA	-40 to 85	28 Ld SSOP	M28.209
ICL3237EIAZ (See Note)	-40 to 85	28 Ld SSOP (Pb-free)	M28.209

\*Add "-T" suffix to part number for tape and reel packaging.

NOTE: Intersil Pb-free products employ special Pb-free material sets; molding compounds/die attach materials and 100% matte tin plate termination finish, which is compatible with both SnPb and Pb-free soldering operations. Intersil Pb-free products are MSL classified at Pb-free peak reflow temperatures that meet or exceed the Pb-free requirements of IPC/JEDEC J Std-020B.

Pin Descriptions

PIN	FUNCTION
V <sub>CC</sub>	System power supply input (3.0V to 5.5V).
V+	Internally generated positive transmitter supply (+5.5V).
V-	Internally generated negative transmitter supply (-5.5V).
GND	Ground connection.
C1+	External capacitor (voltage doubler) is connected to this lead.
C1-	External capacitor (voltage doubler) is connected to this lead.
C2+	External capacitor (voltage inverter) is connected to this lead.
C2-	External capacitor (voltage inverter) is connected to this lead.
T <sub>IN</sub>	TTL/CMOS compatible transmitter Inputs (Note 2).
T <sub>OUT</sub>	±15kV ESD Protected, RS-232 level (nominally ±5.5V) transmitter outputs.
R <sub>IN</sub>	±15kV ESD Protected, RS-232 compatible receiver inputs.
R <sub>OUT</sub>	TTL/CMOS level receiver outputs.
R <sub>OUTB</sub>	TTL/CMOS level, noninverting, always enabled receiver output.
$\overline{\text{EN}}$	Active low receiver enable control; doesn't disable R <sub>OUTB</sub> output (Note 2).
$\overline{\text{SHDN}}$	Active low input to shut down transmitters and on-board power supply, to place device in low power mode (Note 2).
MBAUD	Input low selects 250kbps data rate, and input high selects 1Mbps data rate (Note 2).

NOTE:

- These input pins incorporate positive feedback resistors. Once the input is driven to a valid logic level, the feedback resistor maintains that logic level until V<sub>CC</sub> is removed.

Typical Operating Circuit

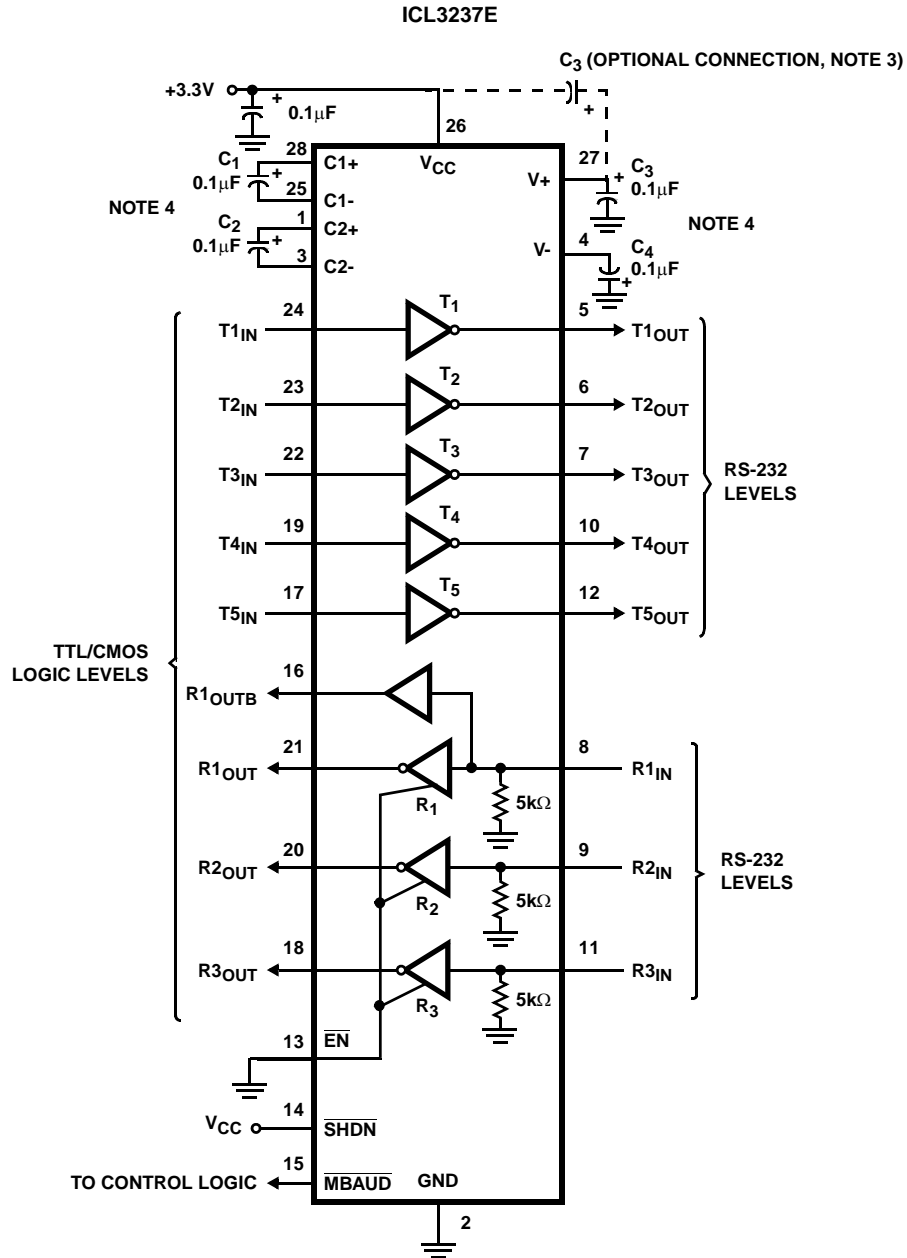

NOTES:

3. THE NEGATIVE TERMINAL OF C<sub>3</sub> CAN BE CONNECTED TO EITHER V<sub>CC</sub> OR GND.
4. FOR V<sub>CC</sub> = 3.15V (3.3V -5%), USE C<sub>1</sub> - C<sub>4</sub> = 0.1µF OR GREATER. FOR V<sub>CC</sub> = 3.0V (3.3V -10%), USE C<sub>1</sub> - C<sub>4</sub> = 0.22µF.

# ICL3237E

## Absolute Maximum Ratings

V <sub>CC</sub> to Ground	-0.3V to 6V
V <sub>+</sub> to Ground	-0.3V to 7V
V <sub>-</sub> to Ground	+0.3V to -7V
V <sub>+</sub> to V <sub>-</sub>	14V
Input Voltages	
T <sub>IN</sub> , EN, SHDN, MBAUD	-0.3V to 6V
R <sub>IN</sub>	±25V
Output Voltages	
T <sub>OUT</sub>	±13.2V
R <sub>OUT</sub>	-0.3V to V <sub>CC</sub> +0.3V
Short Circuit Duration	
T <sub>OUT</sub>	Continuous
ESD Rating	See Specification Table

## Thermal Information

Thermal Resistance (Typical, Note 5)	θ <sub>JA</sub> (°C/W)
28 Ld SSOP Package	100
Moisture Sensitivity (see Technical Brief TB363)	
SSOP Package	Level 1
Maximum Junction Temperature (Plastic Package)	150°C
Maximum Storage Temperature Range	-65°C to 150°C
Maximum Lead Temperature (Soldering 10s)	300°C (Lead Tips Only)

## Operating Conditions

Temperature Range	
ICL3237EC	0°C to 70°C
ICL3237EI	-40°C to 85°C

**CAUTION:** Stresses above those listed in "Absolute Maximum Ratings" may cause permanent damage to the device. This is a stress only rating and operation of the device at these or any other conditions above those indicated in the operational sections of this specification is not implied.

### NOTE:

- θ<sub>JA</sub> is measured with the component mounted on a low effective thermal conductivity test board in free air. See Tech Brief TB379 for details.

**Electrical Specifications** Test Conditions: V<sub>CC</sub> = 3.15V to 5.5V, C<sub>1</sub> - C<sub>4</sub> = 0.1μF; V<sub>CC</sub> = 3V, C<sub>1</sub> - C<sub>4</sub> = 0.22μF, Unless Otherwise Specified. Typicals are at T<sub>A</sub> = 25°C

PARAMETER	TEST CONDITIONS	TEMP (°C)	MIN	TYP	MAX	UNITS
<b>DC CHARACTERISTICS</b>						
Supply Current, Powerdown Disabled	All Outputs Unloaded, V <sub>CC</sub> = 3.15V, SHDN = V <sub>CC</sub>	25	-	0.3	1.0	mA
Supply Current, Powerdown	SHDN = GND	25	-	10	300	nA
<b>LOGIC AND TRANSMITTER INPUTS AND RECEIVER OUTPUTS</b>						
Input Logic Threshold Low	T <sub>IN</sub> , EN, SHDN, MBAUD	Full	-	-	0.8	V
Input Logic Threshold High	T <sub>IN</sub> , EN, SHDN, MBAUD	V <sub>CC</sub> = 3.3V	Full	2.0	-	V
		V <sub>CC</sub> = 5.0V	Full	2.4	-	V
Transmitter Input Hysteresis		25	-	0.5	-	V
Input Leakage Current	T <sub>IN</sub> , EN, SHDN, MBAUD (Note 7)	Full	-	±0.01	±1.0	μA
Output Leakage Current	EN = V <sub>CC</sub> (Receivers Disabled)	Full	-	±0.05	±10	μA
Output Voltage Low	I <sub>OUT</sub> = 1.6mA	Full	-	-	0.4	V
Output Voltage High	I <sub>OUT</sub> = -1.0mA	Full	V <sub>CC</sub> -0.6	V <sub>CC</sub> -0.1	-	V
<b>RECEIVER INPUTS</b>						
Input Voltage Range		Full	-25	-	25	V
Input Threshold Low	V <sub>CC</sub> = 3.3V	25	0.6	1.2	-	V
	V <sub>CC</sub> = 5.0V	25	0.8	1.5	-	V
Input Threshold High	V <sub>CC</sub> = 3.3V to 5.0V	25	-	1.6	2.4	V
Input Hysteresis		25	-	0.5	-	V
Input Resistance		25	3	5	7	kΩ
<b>TRANSMITTER OUTPUTS</b>						
Output Voltage Swing	All Transmitter Outputs Loaded with 3kΩ to Ground	Full	±5.0	±5.4	-	V
Output Resistance	V <sub>CC</sub> = V <sub>+</sub> = V <sub>-</sub> = 0V, Transmitter Output = ±2V	Full	300	10M	-	Ω
Output Short-Circuit Current		Full	-	±35	±60	mA
Output Leakage Current	V <sub>OUT</sub> = ±12V, V <sub>CC</sub> = 0V or 3V to 5.5V, SHDN = GND	Full	-	-	±25	μA

## ICL3237E

**Electrical Specifications** Test Conditions:  $V_{CC} = 3.15V$  to  $5.5V$ ,  $C_1 - C_4 = 0.1\mu F$ ;  $V_{CC} = 3V$ ,  $C_1 - C_4 = 0.22\mu F$ , Unless Otherwise Specified. Typicals are at  $T_A = 25^\circ C$  (Continued)

PARAMETER	TEST CONDITIONS			TEMP (°C)	MIN	TYP	MAX	UNITS
<b>TIMING CHARACTERISTICS</b>								
Maximum Data Rate	$R_L = 3k\Omega$ , One Transmitter Switching	$C_L = 1000pF$	MBAUD = GND	Full	250	700	-	kbps
		$V_{CC} = 3V$ to $4.5V$ , $C_L = 250pF$	MBAUD = $V_{CC}$	Full	1000	1700	-	kbps
		$V_{CC} = 4.5V$ to $5.5V$ , $C_L = 1000pF$	MBAUD = $V_{CC}$	Full	1000	1100	-	kbps
Receiver Propagation Delay	Receiver Input to Receiver Output, $C_L = 150pF$	$t_{PHL}$		25	-	0.15	-	$\mu s$
		$t_{PLH}$		25	-	0.15	-	$\mu s$
Receiver Output Enable Time	Normal Operation			25	-	200	-	ns
Receiver Output Disable Time	Normal Operation			25	-	200	-	ns
Transmitter Skew	$t_{PHL} - t_{PLH}$ , Note 6	MBAUD = GND		25	-	100		ns
		MBAUD = $V_{CC}$ , $V_{CC} = 3.0V$		25	-	25		ns
Receiver Skew	$t_{PHL} - t_{PLH}$ , $C_L = 150pF$			25	-	50	-	ns
Transition Region Slew Rate	$V_{CC} = 3.3V$ , $R_L = 3k\Omega$ to $7k\Omega$ , Measured From $3V$ to $-3V$ or $-3V$ to $3V$	$C_L = 150pF$ to $1000pF$	MBAUD = GND	25	6	17	30	$V/\mu s$
			MBAUD = $V_{CC}$	25	24	40	150	$V/\mu s$
		$C_L = 150pF$ to $2500pF$	MBAUD = GND	25	4	12	30	$V/\mu s$
<b>ESD PERFORMANCE</b>								
RS-232 Pins ( $T_{OUT}$ , $R_{IN}$ )	Human Body Model			25	-	$\pm 15$	-	kV
	IEC61000-4-2 Air Gap Discharge			25	-	$\pm 15$	-	kV
	IEC61000-4-2 Contact Discharge			25	-	$\pm 8$	-	kV
All Other Pins	Human Body Model			25	-	$\pm 2.5$	-	kV

**NOTES:**

6. Skew is measured at the input switching points (1.4V).
7. These inputs utilize a positive feedback resistor. The input current is negligible when the input is at either supply rail.

## Detailed Description

The ICL3237E operates from a single +3V to +5.5V supply, guarantees a 1Mbps minimum data rate ( $MBAUD = V_{CC}$ ), requires only four small external 0.1 $\mu$ F (0.22 $\mu$ F for  $V_{CC} = 3.0V$ ) capacitors, features low power consumption, and meets all EIA/TIA-232 and V.28 specifications. The circuit is divided into three sections: The charge pump, the transmitters, and the receivers.

### Charge-Pump

Intersil's new ICL32XX family utilizes regulated on-chip dual charge pumps as voltage doublers, and voltage inverters to generate  $\pm 5.5V$  transmitter supplies from a  $V_{CC}$  supply as low as 3.0V. This allows these devices to maintain RS-232 compliant output levels over the  $\pm 10\%$  tolerance range of 3.3V powered systems. The efficient on-chip power supplies require only four small, external 0.1 $\mu$ F capacitors for the voltage doubler and inverter functions at  $V_{CC} = 3.3V$ . See the "Capacitor Selection" section, and Table 3 for capacitor recommendations for other operating conditions. The charge pumps operate discontinuously (i.e., they turn off as soon as the V+ and V- supplies are pumped up to the nominal values), resulting in significant power savings.

### Transmitters

The transmitters are proprietary, low dropout, inverting drivers that translate TTL/CMOS inputs to EIA/TIA-232 output levels. Coupled with the on-chip  $\pm 5.5V$  supplies, these transmitters deliver true RS-232 levels over a wide range of single supply system voltages.

All transmitter outputs disable and assume a high impedance state when the device enters the powerdown mode (see Table 2). These outputs may be driven to  $\pm 12V$  when disabled.

The ICL3237E guarantees a 1Mbps data rate ( $MBAUD = V_{CC}$ ) for full load conditions (3k $\Omega$  and 250pF),  $V_{CC} \geq 3.0V$ , with one transmitter operating at full speed. Under more typical conditions of  $V_{CC} \geq 3.3V$ ,  $C_{1-4} = 0.1\mu F$ ,  $R_L = 3k\Omega$ , and  $C_L = 250pF$ , one transmitter easily operates at 1.7Mbps.

Transmitter inputs incorporate an active positive feedback resistor that maintains the last driven input state in the absence of a forcing signal. Unused transmitter inputs may be left unconnected.

### Receivers

The ICL3237E contains standard inverting receivers that tristate only when the  $\overline{EN}$  control line is driven high. Additionally, it includes a noninverting (monitor) receiver (denoted by the  $R_{OUTB}$  label) that is always active, regardless of the state of any control lines. All the receivers convert RS-232 signals to CMOS output levels and accept inputs up to  $\pm 25V$  while presenting the required 3k $\Omega$  to 7k $\Omega$  input impedance (see Figure 1) even if the power is off ( $V_{CC} = 0V$ ). The receivers' Schmitt trigger input stage uses

hysteresis to increase noise immunity and decrease errors due to slow input signal transitions.

Monitor receivers remain active even during manual powerdown and forced receiver disable, making them extremely useful for Ring Indicator monitoring. Standard receivers driving powered down peripherals must be disabled to prevent current flow through the peripheral's protection diodes (see Figures 2 and 3). This renders them useless for wake up functions, but the corresponding monitor receiver can be dedicated to this task as shown in Figure 3.

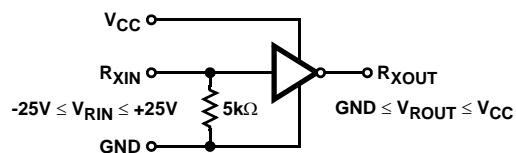

FIGURE 1. INVERTING RECEIVER CONNECTIONS

### Powerdown Functionality

This 3V device requires a nominal supply current of 0.3mA during normal operation (not in powerdown mode). This is considerably less than the 5mA to 11mA current required of 5V RS-232 devices. The already low current requirement drops significantly when the device enters powerdown mode. In powerdown, supply current drops to 10nA, because the on-chip charge pump turns off ( $V+$  collapses to  $V_{CC}$ ,  $V-$  collapses to GND), and the transmitter outputs tristate. This micro-power mode makes the ICL3237E ideal for battery powered and portable applications.

### Software Controlled (Manual) Powerdown

On the ICL3237E, the powerdown control is via a simple shutdown ( $\overline{SHDN}$ ) pin. Driving this pin high enables normal operation, while driving it low forces the IC into its powerdown state. Connect  $\overline{SHDN}$  to  $V_{CC}$  if the powerdown function isn't needed. Note that all the receiver outputs remain enabled during shutdown (see Table 2). For the lowest power consumption during powerdown, the receivers should also be disabled by driving the  $\overline{EN}$  input high (see next section, and Figures 2 and 3). The time required to exit powerdown, and resume transmission is only 100 $\mu$ s.

TABLE 2. POWERDOWN AND ENABLE LOGIC TRUTH TABLE

SHDN INPUT	EN INPUT	TRANSMITTER OUTPUTS	RECEIVER OUTPUTS	R <sub>OUTB</sub> OUTPUT	MODE OF OPERATION
L	L	High-Z	Active	Active	Manual Powerdown
L	H	High-Z	High-Z	Active	Manual Powerdown w/Rcvr. Disabled
H	L	Active	Active	Active	Normal Operation
H	H	Active	High-Z	Active	Normal Operation w/Rcvr. Disabled

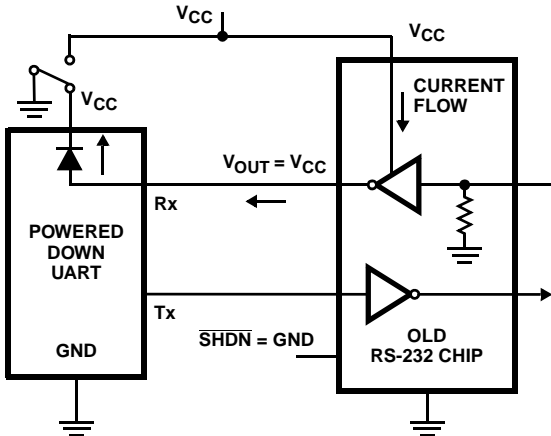

FIGURE 2. POWER DRAIN THROUGH POWERED DOWN PERIPHERAL

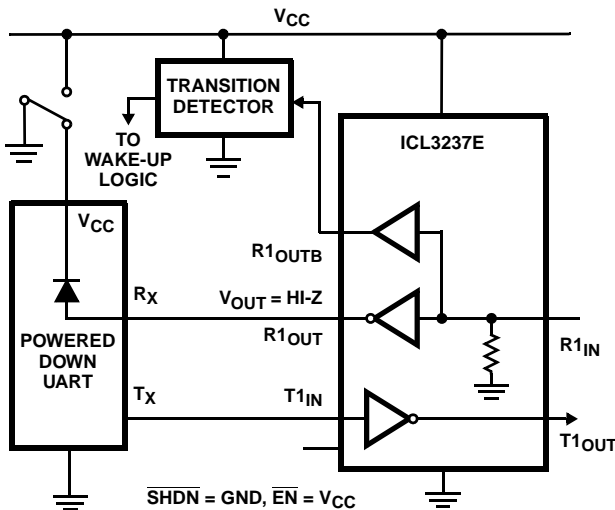

FIGURE 3. DISABLED RECEIVERS PREVENT POWER DRAIN

**Receiver ENABLE Control**

This device also features an EN input to control the receiver outputs. Driving EN high disables all the inverting (standard) receiver outputs placing them in a high impedance state. This is useful to eliminate supply current, due to a receiver output forward biasing the protection diode, when driving the input of a powered down (V<sub>CC</sub> = GND) peripheral (see Figure 2). The enable input has no effect on transmitter nor monitor (R<sub>OUTB</sub>) outputs.

**MegaBaud Selection**

In normal operating mode (MBAUD = GND), the ICL3237E transmitters guarantee a 250kbps data rate with worst-case loads of 3kΩ in parallel with 1000pF. This provides compatibility with PC-to-PC communication software, such as Laplink™.

For higher speed serial communications, the ICL3237E features MegaBaud operation. In MegaBaud operating mode (MBAUD = V<sub>CC</sub>), the ICL3237E transmitters guarantee a 1Mbps data rate with worst-case loads of 3kΩ in parallel with 250pF for 3.0V < V<sub>CC</sub> < 4.5V. For 5V ±10% operation, the ICL3237E transmitters guarantee a 1Mbps data rate with worst-case loads of 3kΩ in parallel with 1000pF.

**Capacitor Selection**

The charge pumps require 0.1μF capacitors for 3.3V (5% tolerance) operation. For other supply voltages refer to Table 3 for capacitor values. Do not use values smaller than those listed in Table 3. Increasing the capacitor values (by a factor of 2) reduces ripple on the transmitter outputs and slightly reduces power consumption. C<sub>2</sub>, C<sub>3</sub>, and C<sub>4</sub> can be increased without increasing C<sub>1</sub>'s value, however, do not increase C<sub>1</sub> without also increasing C<sub>2</sub>, C<sub>3</sub>, and C<sub>4</sub> to maintain the proper ratios (C<sub>1</sub> to the other capacitors).

When using minimum required capacitor values, make sure that capacitor values do not degrade excessively with temperature. If in doubt, use capacitors with a larger nominal value. The capacitor's equivalent series resistance (ESR) usually rises at low temperatures and it influences the amount of ripple on V<sub>+</sub> and V<sub>-</sub>.

TABLE 3. REQUIRED CAPACITOR VALUES

V <sub>CC</sub> (V)	C <sub>1</sub> (μF)	C <sub>2</sub> , C <sub>3</sub> , C <sub>4</sub> (μF)
3.0 to 3.6 (3.3V ±10%)	0.22	0.22
3.15 to 3.6 (3.3V ±5%)	0.1	0.1
4.5 to 5.5	0.047	0.33
3.0 to 5.5	0.22	1.0

**Power Supply Decoupling**

In most circumstances a 0.1μF bypass capacitor is adequate. In applications that are particularly sensitive to power supply noise, decouple V<sub>CC</sub> to ground with a capacitor of the same value as the charge-pump capacitor C<sub>1</sub>. Connect the bypass capacitor as close as possible to the IC.

**Operation Down to 2.7V**

ICL3237E transmitter outputs meet RS-562 levels ( $\pm 3.7V$ ), at the full data rate, with  $V_{CC}$  as low as 2.7V. RS-562 levels typically ensure inter operability with RS-232 devices.

**Transmitter Outputs when Exiting Powerdown**

Figure 4 shows the response of two transmitter outputs when exiting powerdown mode. As they activate, the two transmitter outputs properly go to opposite RS-232 levels, with no glitching, ringing, nor undesirable transients. Each transmitter is loaded with  $3k\Omega$  in parallel with  $2500pF$ . Note that the transmitters enable only when the magnitude of the supplies exceed approximately 3V.

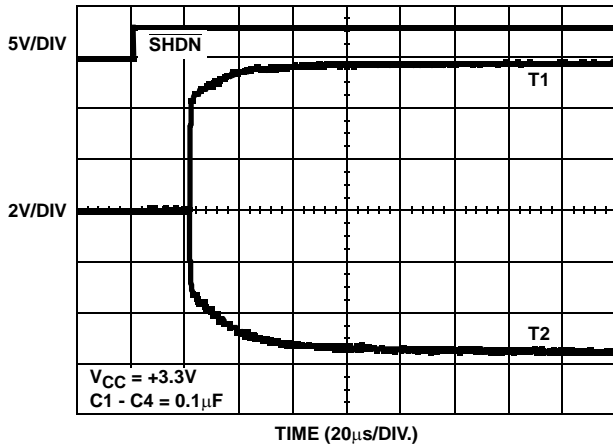

FIGURE 4. TRANSMITTER OUTPUTS WHEN EXITING POWERDOWN

**High Data Rates**

The ICL3237E maintains the RS-232  $\pm 5V$  minimum transmitter output voltages even at high data rates. Figure 5 details a transmitter loopback test circuit, and Figure 6 illustrates the standard speed loopback test result for a single transmitter driving  $1000pF$  and an RS-232 load at 250kbps. Figure 7 shows the MegaBaud loopback results for a single transmitter driving  $250pF$  and an RS-232 load at 1Mbps. The static transmitters were also loaded with an RS-232 receiver.

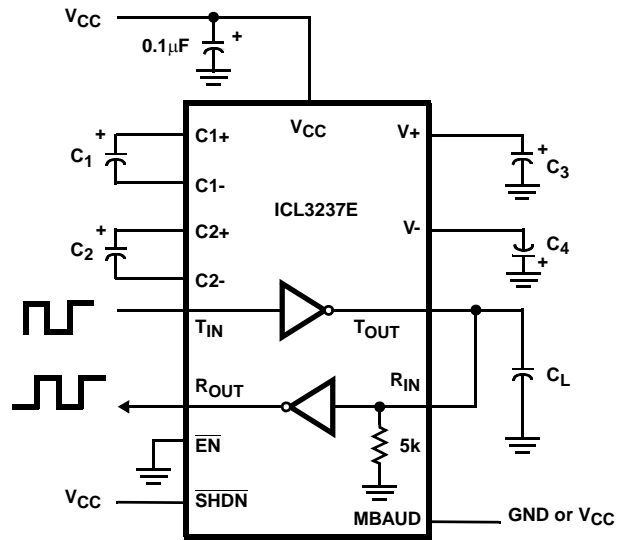

FIGURE 5. TRANSMITTER LOOPBACK TEST CIRCUIT

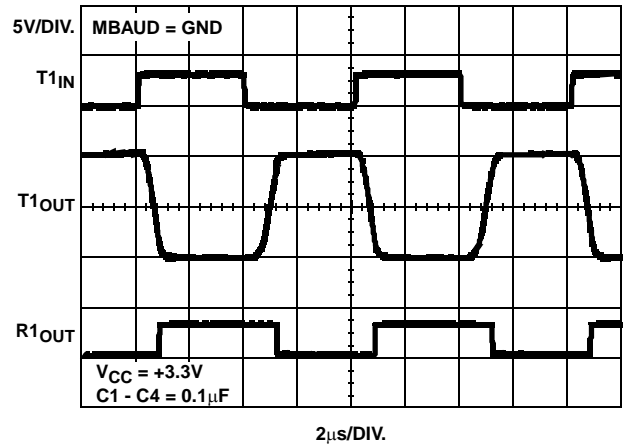

FIGURE 6. LOOPBACK TEST AT 250kbps ( $C_L = 1000pF$ )

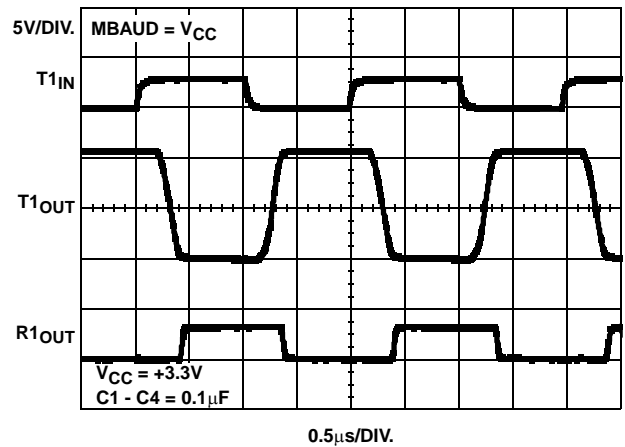

FIGURE 7. LOOPBACK TEST AT 1Mbps ( $C_L = 250pF$ )



### Interconnection with 3V and 5V Logic

The ICL3237E directly interfaces with 5V CMOS and TTL logic families. Nevertheless, with the ICL32XX at 3.3V, and the logic supply at 5V, AC, HC, and CD4000 outputs can drive ICL32XX inputs, but ICL32XX outputs do not reach the minimum  $V_{IH}$  for these logic families. See Table 4 for more information.

**TABLE 4. LOGIC FAMILY COMPATIBILITY WITH VARIOUS SUPPLY VOLTAGES**

SYSTEM POWER-SUPPLY VOLTAGE (V)	V <sub>CC</sub> SUPPLY VOLTAGE (V)	COMPATIBILITY
3.3	3.3	Compatible with all CMOS families.
5	5	Compatible with all TTL and CMOS logic families.
5	3.3	Compatible with ACT and HCT CMOS, and with TTL. ICL32XX outputs are incompatible with AC, HC, and CD4000 CMOS inputs.

### ±15kV ESD Protection

All pins on ICL32XX devices include ESD protection structures, but the ICL32XXE family incorporates advanced structures which allow the RS-232 pins (transmitter outputs and receiver inputs) to survive ESD events up to ±15kV. The RS-232 pins are particularly vulnerable to ESD damage because they typically connect to an exposed port on the exterior of the finished product. Simply touching the port pins, or connecting a cable, can cause an ESD event that might destroy unprotected ICs. These new ESD structures protect the device whether or not it is powered up, protect without allowing any latchup mechanism to activate, and don't interfere with RS-232 signals as large as ±25V.

### Human Body Model (HBM) Testing

As the name implies, this test method emulates the ESD event delivered to an IC during human handling. The tester delivers the charge through a 1.5kΩ current limiting resistor, making the test less severe than the IEC61000 test which utilizes a 330Ω limiting resistor. The HBM method determines an IC's ability to withstand the ESD transients typically present during handling and manufacturing. Due to the random nature of these events, each pin is tested with respect to all other pins. The RS-232 pins on "E" family devices can withstand HBM ESD events to ±15kV.

### IEC61000-4-2 Testing

The IEC61000 test method applies to finished equipment, rather than to an individual IC. Therefore, the pins most likely to suffer an ESD event are those that are exposed to the outside world (the RS-232 pins in this case), and the IC is tested in its typical application configuration (power applied) rather than testing each pin-to-pin combination. The lower current limiting resistor coupled with the larger charge storage capacitor yields a test that is much more severe than the HBM test. The extra ESD protection built into this device's RS-232 pins allows the design of equipment meeting level 4 criteria without the need for additional board level protection on the RS-232 port.

### AIR-GAP DISCHARGE TEST METHOD

For this test method, a charged probe tip moves toward the IC pin until the voltage arcs to it. The current waveform delivered to the IC pin depends on approach speed, humidity, temperature, etc., so it is difficult to obtain repeatable results. The "E" device RS-232 pins withstand ±15kV air-gap discharges.

### CONTACT DISCHARGE TEST METHOD

During the contact discharge test, the probe contacts the tested pin before the probe tip is energized, thereby eliminating the variables associated with the air-gap discharge. The result is a more repeatable and predictable test, but equipment limits prevent testing devices at voltages higher than ±8kV. All "E" family devices survive ±8kV contact discharges on the RS-232 pins.

Typical Performance Curves  $V_{CC} = 3.3V, T_A = 25^\circ C$

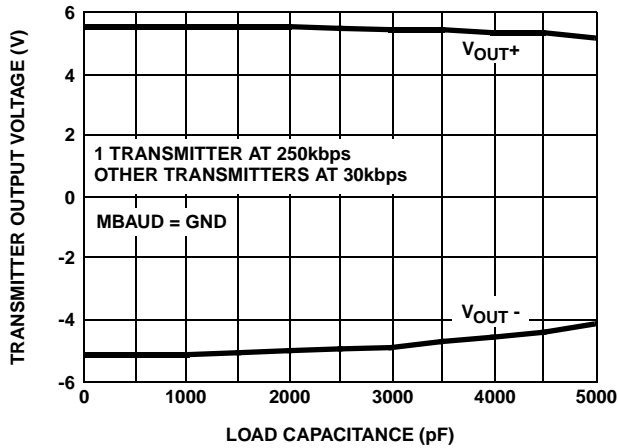

FIGURE 8. LOW SPEED TRANSMITTER OUTPUT VOLTAGE vs LOAD CAPACITANCE

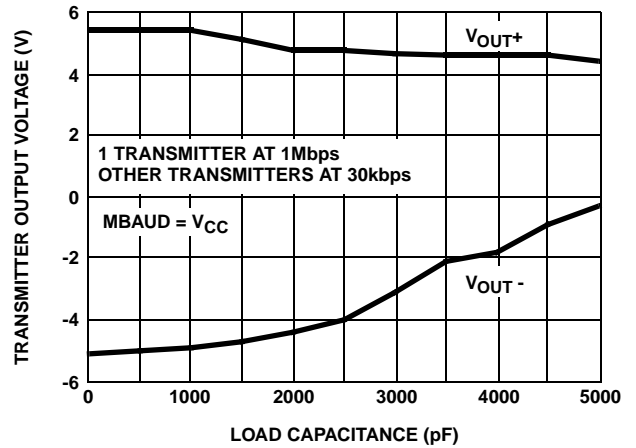

FIGURE 9. HIGH SPEED TRANSMITTER OUTPUT VOLTAGE vs LOAD CAPACITANCE

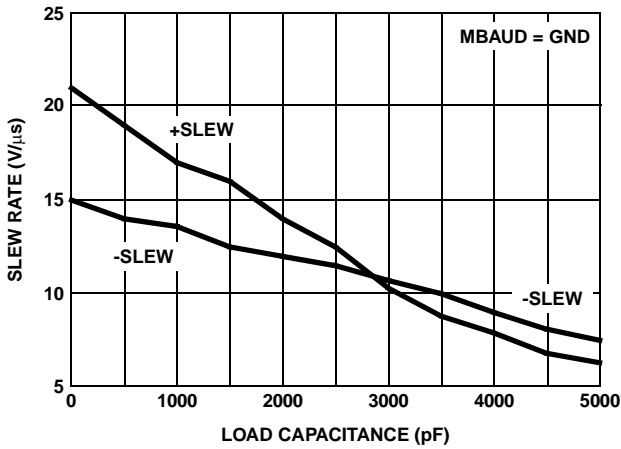

FIGURE 10. LOW SPEED SLEW RATE vs LOAD CAPACITANCE

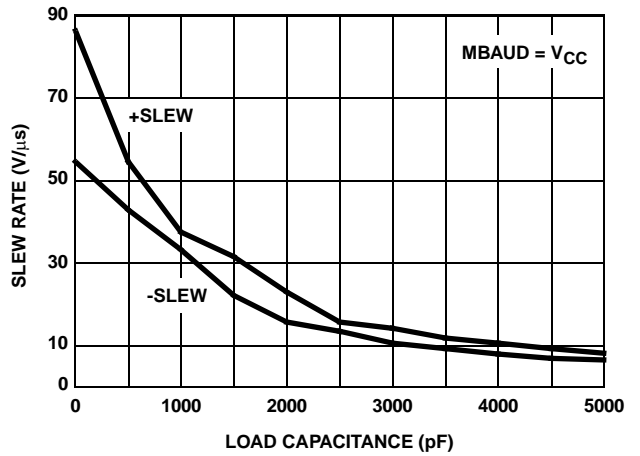

FIGURE 11. HIGH SPEED SLEW RATE vs LOAD CAPACITANCE

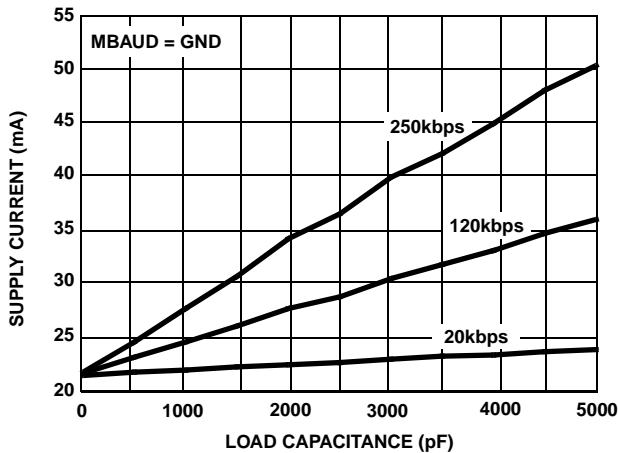

FIGURE 12. LOW SPEED SUPPLY CURRENT vs LOAD CAPACITANCE WHEN TRANSMITTING DATA

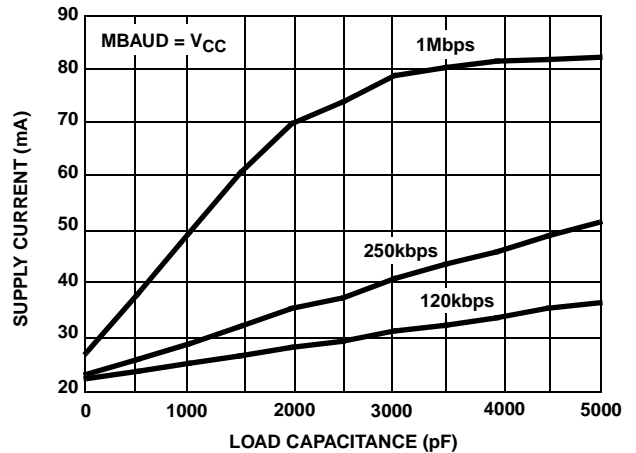

FIGURE 13. HIGH SPEED SUPPLY CURRENT vs LOAD CAPACITANCE WHEN TRANSMITTING DATA

**Typical Performance Curves**  $V_{CC} = 3.3V, T_A = 25^\circ C$  (Continued)

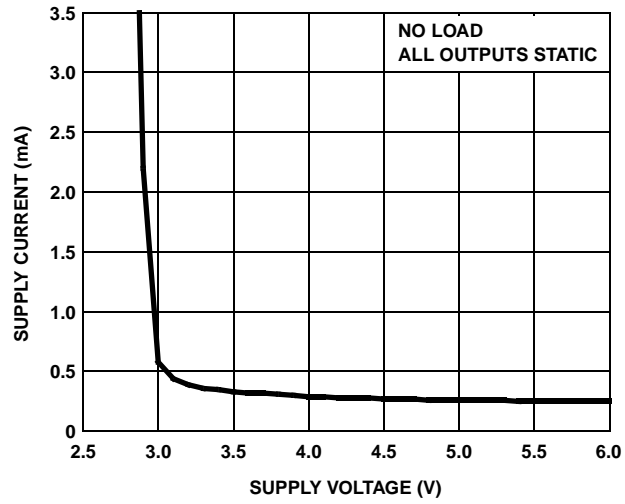

FIGURE 14. SUPPLY CURRENT vs SUPPLY VOLTAGE

**Die Characteristics**

**SUBSTRATE POTENTIAL (POWERED UP):**

GND

**TRANSISTOR COUNT:**

619

**PROCES**

Si Gate CMOS

Shrink Small Outline Plastic Packages (SSOP)

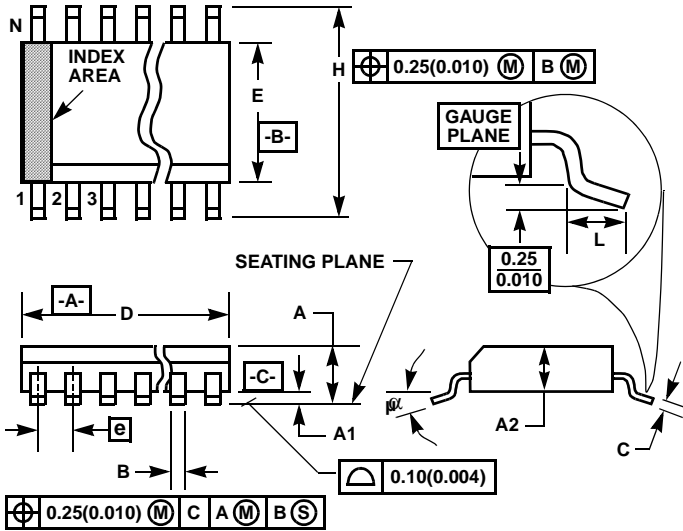

M28.209 (JEDEC MO-150-AH ISSUE B)  
28 LEAD SHRINK SMALL OUTLINE PLASTIC PACKAGE

SYMBOL	INCHES		MILLIMETERS		NOTES
	MIN	MAX	MIN	MAX	
A	-	0.078	-	2.00	-
A1	0.002	-	0.05	-	-
A2	0.065	0.072	1.65	1.85	-
B	0.009	0.014	0.22	0.38	9
C	0.004	0.009	0.09	0.25	-
D	0.390	0.413	9.90	10.50	3
E	0.197	0.220	5.00	5.60	4
e	0.026 BSC		0.65 BSC		-
H	0.292	0.322	7.40	8.20	-
L	0.022	0.037	0.55	0.95	6
N	28		28		7
$\alpha$	0°	8°	0°	8°	-

NOTES:

8. Symbols are defined in the "MO Series Symbol List" in Section 2.2 of Publication Number 95.
9. Dimensioning and tolerancing per ANSI Y14.5M-1982.
10. Dimension "D" does not include mold flash, protrusions or gate burrs. Mold flash, protrusion and gate burrs shall not exceed 0.20mm (0.0078 inch) per side.
11. Dimension "E" does not include interlead flash or protrusions. Interlead flash and protrusions shall not exceed 0.20mm (0.0078 inch) per side.
12. The chamfer on the body is optional. If it is not present, a visual index feature must be located within the crosshatched area.
13. "L" is the length of terminal for soldering to a substrate.
14. "N" is the number of terminal positions.
15. Terminal numbers are shown for reference only.
16. Dimension "B" does not include dambar protrusion. Allowable dambar protrusion shall be 0.13mm (0.005 inch) total in excess of "B" dimension at maximum material condition.
17. Controlling dimension: MILLIMETER. Converted inch dimensions are not necessarily exact.

Rev. 1 3/95

All Intersil U.S. products are manufactured, assembled and tested utilizing ISO9000 quality systems.  
Intersil Corporation's quality certifications can be viewed at [www.intersil.com/design/quality](http://www.intersil.com/design/quality)

*Intersil products are sold by description only. Intersil Corporation reserves the right to make changes in circuit design, software and/or specifications at any time without notice. Accordingly, the reader is cautioned to verify that data sheets are current before placing orders. Information furnished by Intersil is believed to be accurate and reliable. However, no responsibility is assumed by Intersil or its subsidiaries for its use; nor for any infringements of patents or other rights of third parties which may result from its use. No license is granted by implication or otherwise under any patent or patent rights of Intersil or its subsidiaries.*

For information regarding Intersil Corporation and its products, see [www.intersil.com](http://www.intersil.com)