

CAN BUS TRANSCEIVER

- L9615 MEETS ISO/DIS 11898 UP TO 500KBAUD
- TRANSMITTER
 - GENERATION OF DIFFERENTIAL OUTPUT SIGNALS
 - SHORT CIRCUIT PROTECTED FROM -5V TO 36V, DETECTION & SHUTDOWN
 - SLOPE CONTROL TO REDUCE RFI AND EMI
 - TWO STATES ADJUSTABLE SLOPE CONTROL ($\leq 500\text{KBAUD}/\leq 125\text{KBAUD}$)
- RECEIVER
 - DIFFERENTIAL INPUT WITH HIGH INTERFERENCE SUPPRESSION
 - COMMON MODE INPUT VOLTAGE RANGE (V_{COM}) FROM -2V TO $V_{\text{S}}+3\text{V}$
- PACKAGE: SO 8

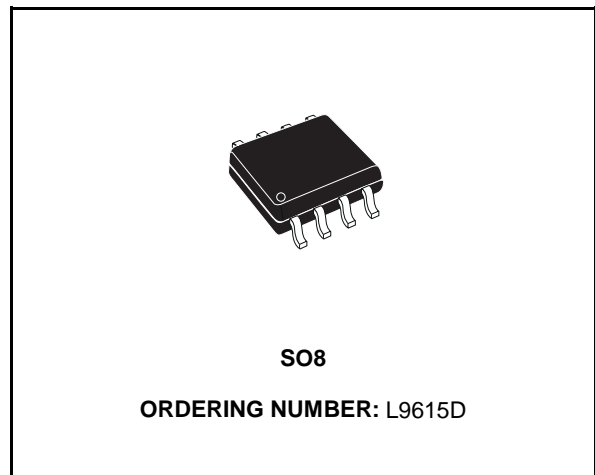

DESCRIPTION

The L9615 is a bidirectional transceiver for signal

conditioning and processing in connection with a CAN controller. Data rates of up to 500KBAUD are supported using either shielded or non-shielded pair of lines.

BLOCK DIAGRAM

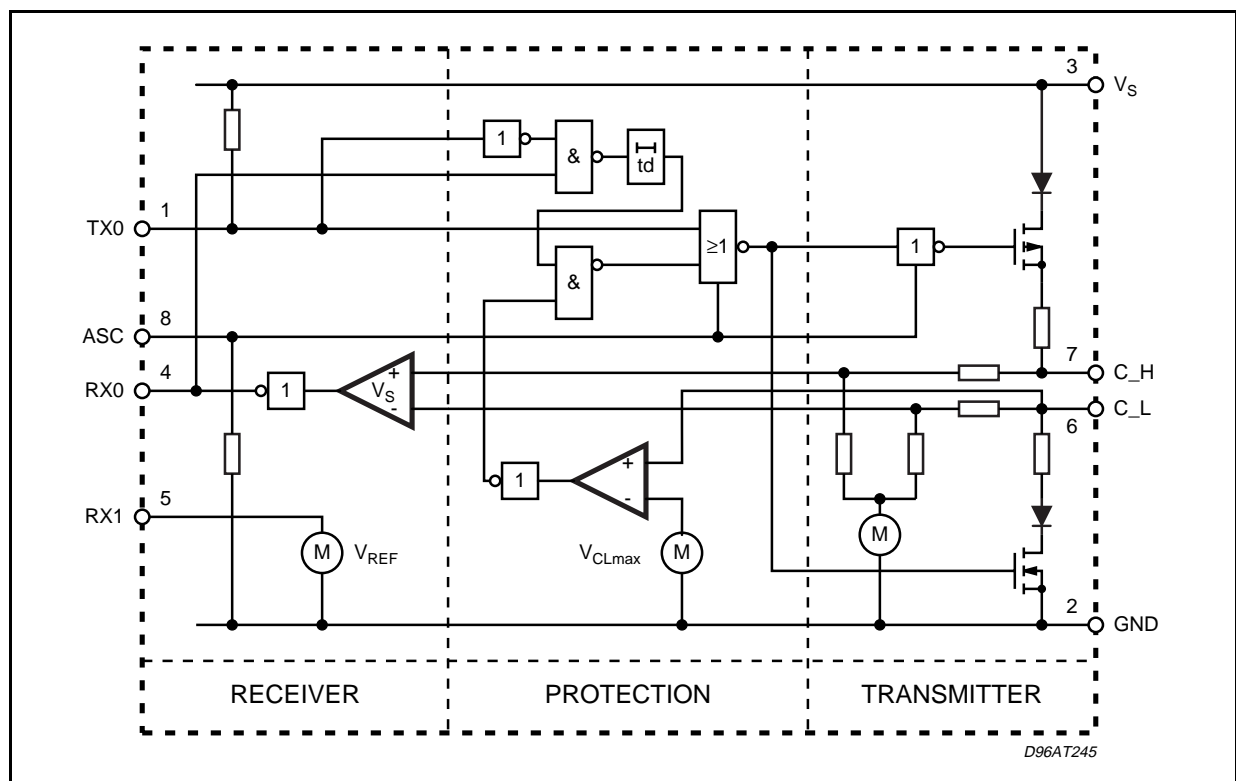

ABSOLUTE MAXIMUM RATINGS

| Symbol | Parameter | Value | Unit |
|----------------------|--|-------------------------|------|
| V_S | Supply Voltage | -0.3 to 7 | V |
| V_{C_H}, V_{C_L} | Bus Voltage at C_H, C_L (VS 0 to 5.5V) | -5 to 36 | V |
| I_{C_H}, I_{C_L} | Off State Leakage Current at C_H, C_L (VS =0 to 5.5V, $V_{C_H} = -5$ to 36V, $V_{C_L} = -5$ to 36) | -3 to 5 | mA |
| V_{DC} | DC Voltage at TXO, ASC (VS 0 to 5.5V) | GND -0.3 to $V_S + 0.3$ | V |
| I_{RXO} | Output Current at RXO (VS 0 to 5.5V) | -0.3 to 1 | mA |
| T_{stg}, T_J | Storage and Junction Temperature Range | -40 to 150 | °C |
| T_{op} | Operating Temperature Range | -40 to 110 | °C |

All voltages, except bus voltage, are defined with respect to pin 2
Positive currents flow into the IC.

PIN CONNECTION

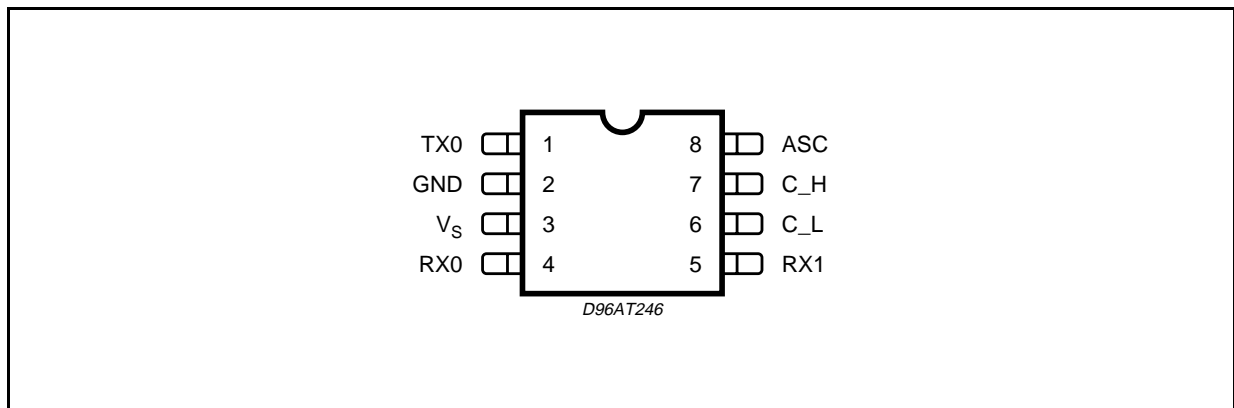

THERMAL DATA

| Symbol | Parameter | Value | Unit |
|--------|-----------|-------|------|
| | | | |
| | | | |

PIN FUNCTIONS

| N. | Name | Function |
|----|-------|--------------------------|
| 1 | TXO | Transmitter Input |
| 2 | GND | Ground |
| 3 | V_S | Supply Voltage |
| 4 | RXO | Receive Output |
| 5 | RX1 | Reference Voltage |
| 6 | C_L | Low Side Bus Output |
| 7 | C_H | High Side Bus Output |
| 8 | ASC | Adjustable Slope Control |

ELECTRICAL CHARACTERISTICS ($T_{OP} = -40$ to 110°C ; $V_S = 4.5$ to 5.5V ; Dominant: $V_{TXO} = \text{GND}$; Recessive: $V_{TXO} = V_S$; All voltages, except bus voltage, are defined with respect to pin 2. Positive currents flow into the IC unless otherwise specified.)

| Symbol | Parameter | Test Condition | Min. | Typ. | Max. | Unit |
|---|--|---|------------|-----------|------------|------------------|
| V_S | Supply Voltage | | 4.5 | 5 | 5.5 | V |
| I_S | Supply Current | Dominant | | | 80 | mA |
| | | Recessive | | | 20 | mA |
| TRANSMITTER SECTION ($R_A = 60\Omega$ between C_H and C_L) | | | | | | |
| C_{TXO} | TXO Input Capacitance | $0\text{V} < V_{TXO} < V_S$ | | 25 | | pF |
| V_{TXO} | TXO High Level Input Voltage | | $0.7 V_S$ | | V_S | |
| | TXO Low Level Input Voltage | | 0 | | $0.3 V_S$ | |
| I_{TXO} | TXO High Level Input Current | $V_{TXO} = V_S$ | -2 | 0 | 2 | μA |
| | TXO Low Level Input Current | $V_{TXO} = \text{GND}$ | -275 | 0 | -25 | μA |
| C_{ASC} | ASC Input Capacitance | $0\text{V} < V_{ASC} < V_S$ | | 25 | | pF |
| V_{ASC} | ASC Input Voltage for High Speed | | 0 | | $0.1 V_S$ | |
| | ASC Input Voltage for Low Speed | | $0.9 V_S$ | | V_S | |
| I_{ASC} | ASC Input Current | $V_{ASC} = V_S$ | 25 | | 275 | μA |
| | | $V_{ASC} = 0\text{V}$ | -2 | 0 | 2 | μA |
| V_{C_H}, V_{C_L} | Bus Voltage Recessive | Recessive | $0.4 V_S$ | $0.5 V_S$ | $0.6 V_S$ | |
| I_{C_H}, I_{C_L} | Leakage Current Recessive | $V_{C_L} = V_{C_H} = -2$ to 7V | -0.7 | | 0.7 | mA |
| | | $V_{C_L} = V_{C_H} = 1$ to 4V | -0.3 | | 0.3 | mA |
| $R_{IN}(C_H, C_L)$ | Input Resistance | Recessive | 5 | | 50 | $\text{K}\Omega$ |
| $R_{Diff}(C_H, C_L)$ | Differential Input Resistance | Recessive | 10 | | 100 | $\text{K}\Omega$ |
| $V_{Diff} = V_{C_H} - V_{C_L}$ | Differential Output Voltage | Dominant, R_A | 1.5 | | 3 | V |
| $V_{Diff} = V_{C_H} - V_{C_L}$ | Differential Output Voltage | Recessive | -500 | 0 | 50 | mV |
| t_d | Short Circuit Detection Time C_H to C_L ; C_H to B | $R_{CS} < 1\Omega$ | 1 | 5 | 10 | μs |
| I_A | Supply Current in Case of Short Circuit, C_H to C_L , C_H to B (time = t_d) | | | 150 | | mA |
| V_{C_Lmax} | Overvoltage Protection Threshold on C_L | | 7 | 8 | 10 | V |
| RECEIVE SECTION | | | | | | |
| V_{RXO} | RXO High Level Output Voltage | $V_{Diff} < 0.5\text{V}$; $I_{RXO} = 0.3\text{mA}$; $V_{C_H} = -2$ to 7V ; $V_{C_L} = -2$ to 7V ; | $0.9 V_S$ | | V_S | V |
| | RXO Low Level Output Voltage | $V_{Diff} > 0.9\text{V}$; $I_{RXO} = 1\text{mA}$; $V_{C_H} = -2$ to 7V ; $V_{C_L} = -2$ to 7V ; | | | 0.5 | V |
| $V_S = V_{C_H} - V_{C_L}$ | Input Signal Threshold | $V_{C_H} = -2$ to 7V ; $V_{C_L} = -2$ to 7V ; | 500 | 700 | 900 | mV |
| $V_{COM} = (V_{C_H} + V_{C_L})/2$ | Input Common Mode Voltage Range | | -2 | | 7 | V |
| V_{HYS} | Differential Input Hysteresis | | | 150 | | mV |
| REFERENCE OUTPUT | | | | | | |
| V_{RX1} | Reference Voltage | $I_{RX1} = 0$ | $0.45 V_S$ | $0.5 V_S$ | $0.55 V_S$ | V |
| R_{RX1} | Output Resistance | | 2 | | 9 | $\text{K}\Omega$ |

L9615

DINAMIC CHARACTERISTICS ($C_A = 47\text{pF}$ between C_H and C_L ; $V_S = 5\text{V}$; $t_R < 5\text{ns}$; $C_{RXO} = 20\text{pF}$ between RXO and B ; $R_A = 60\Omega$ between C_H and C_L)

| Symbol | Parameter | Test Condition | Min. | Typ. | Max. | Unit |
|-----------|---|-----------------------|------|------|------|------------------------|
| t_{OT} | Signal Delay TXO to C_H , C_L | | | | 50 | ns |
| SR | Differential Output Slew Rate (Transmitter) | $V_{ASC} = 0\text{V}$ | 20 | | 50 | $\text{V}/\mu\text{s}$ |
| | | $V_{ASC} = V_S$ | 5 | | 20 | $\text{V}/\mu\text{s}$ |
| t_{OR} | Signal Delay C_H , C_L to RXO | $V_{ASC} = 0\text{V}$ | | | 150 | ns |
| t_{OTR} | Signal Delay Txo to Rxo | $V_{ASC} = 0\text{V}$ | | | 300 | ns |

FUNCTIONAL DESCRIPTION

The L9615 is used as an interface between a CAN controller and the physical bus. The device provides transmitting capability to the CAN controller.

The transmitter outputs C_H and C_L are protected against short circuits and electrical transients which may occur in an automotive environment. In case of short circuit (C_H to C_L , C_H to B) the protection circuit recognizes this fault condition and the transmitter output stages are disabled with a delay of max. $10\mu\text{s}$ to prevent destruction of the IC and high consumption of supply current I_S . If $V_{C_L} > V_{C_Lmax}$ the transmitter output stages would be disabled immediately.

Pin ASC makes it possible to select two different

modes of operation: High speed ($\leq 500\text{kBaud}$) and low speed ($\leq 125\text{kBaud}$).

The ASC pin is tied to GND for normal operation at $\leq 500\text{kBaud}$. For slower speed operation at $\leq 125\text{kBaud}$ the rise and fall slope of the bus output can be decreased to reduce EMI by connecting the ASC pin to V_S .

FUNCTIONAL TABLE

| TXO | C_H | C_L | Bus State | RXO |
|---------------|------------------|------------------|-----------|-----|
| L | H | L | Dominant | L |
| H or Floating | Floating $V_S/2$ | Floating $V_S/2$ | Recessive | H |

TYPICAL APPLICATION

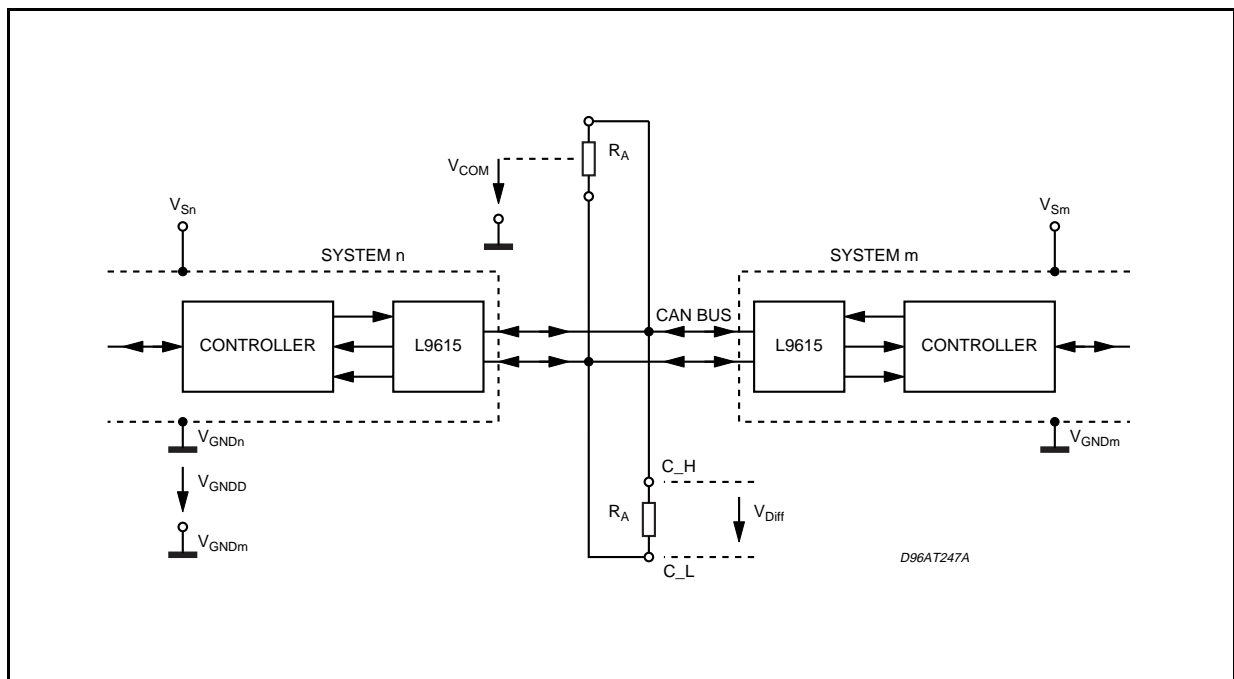

TIMING DIAGRAM



EMC PERFORMANCE (RECEIVER)

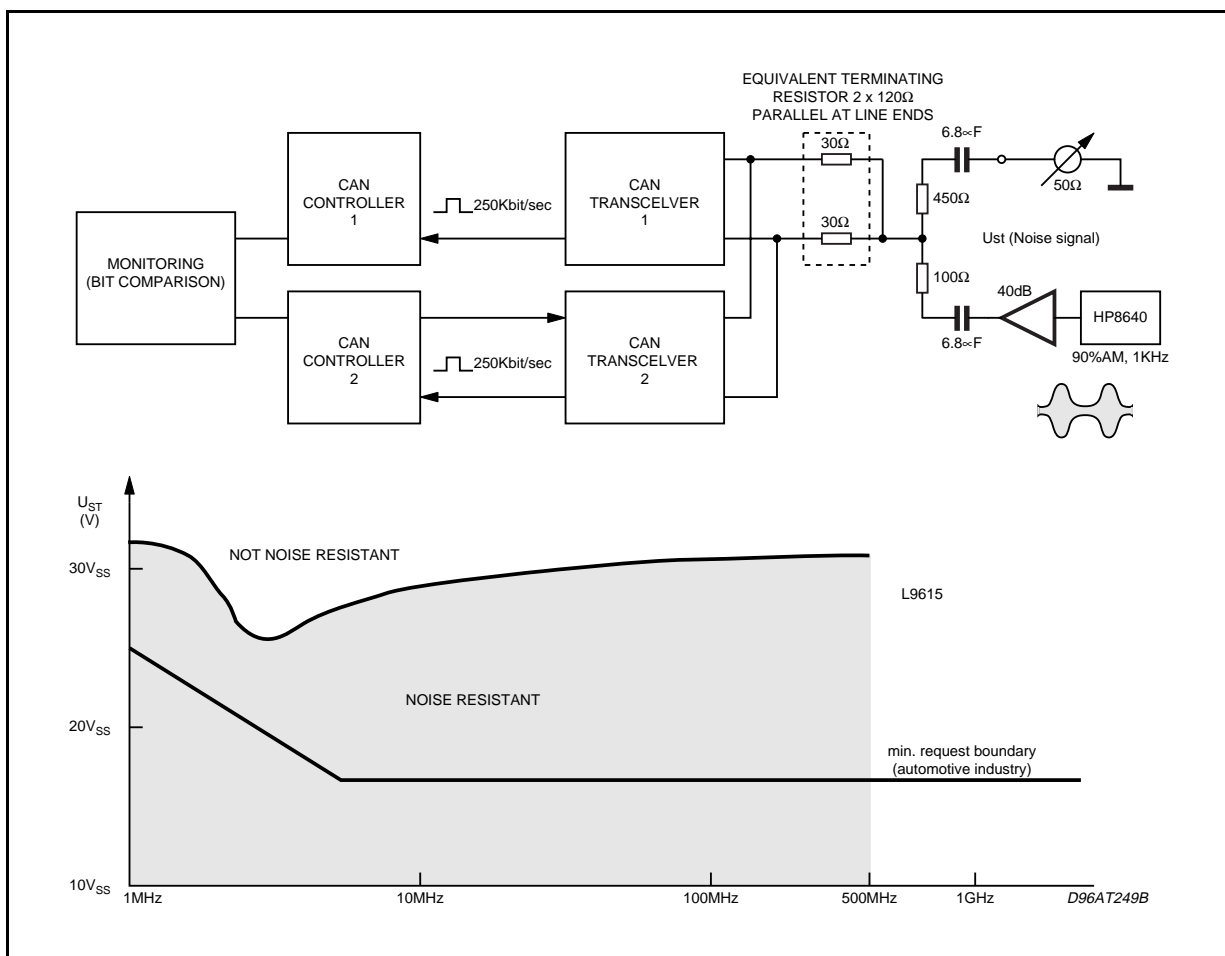

EMC PERFORMANCE (TRANSMITTER)



Transceiver Without Emc Reducing Measures

Transceiver With Emc Reducing Measures

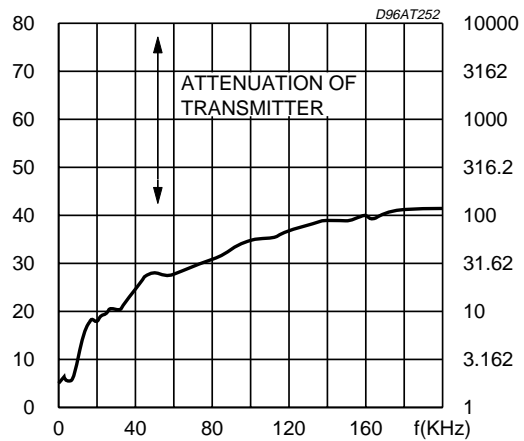
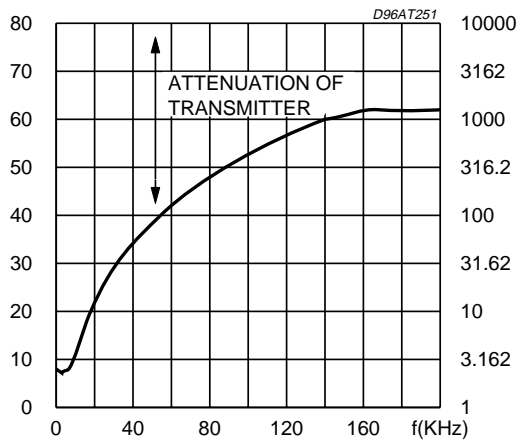

EMC PERFORMANCE (Transceiver Sending)

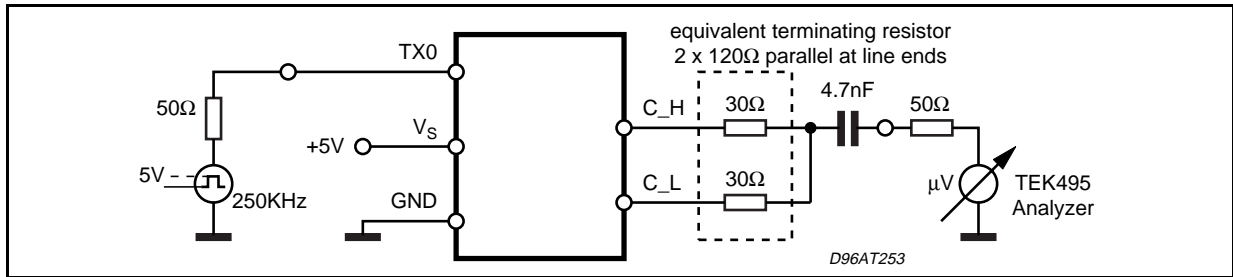

Transceiver Without Emc Reducing Measures

Transceiver With Emc Reducing Measures

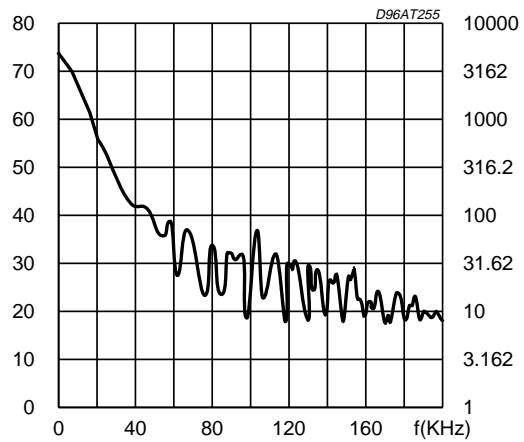
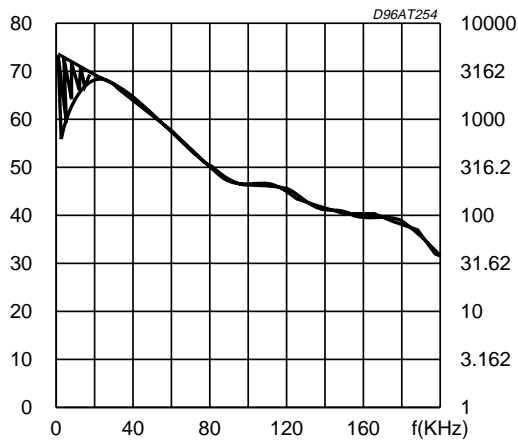

| DIM. | mm | | | inch | | |
|-------|------------|------|------|-------|-------|-------|
| | MIN. | TYP. | MAX. | MIN. | TYP. | MAX. |
| A | | | 1.75 | | | 0.069 |
| a1 | 0.1 | | 0.25 | 0.004 | | 0.010 |
| a2 | | | 1.65 | | | 0.065 |
| a3 | 0.65 | | 0.85 | 0.026 | | 0.033 |
| b | 0.35 | | 0.48 | 0.014 | | 0.019 |
| b1 | 0.19 | | 0.25 | 0.007 | | 0.010 |
| C | 0.25 | | 0.5 | 0.010 | | 0.020 |
| c1 | 45° (typ.) | | | | | |
| D (1) | 4.8 | | 5.0 | 0.189 | | 0.197 |
| E | 5.8 | | 6.2 | 0.228 | | 0.244 |
| e | | 1.27 | | | 0.050 | |
| e3 | | 3.81 | | | 0.150 | |
| F (1) | 3.8 | | 4.0 | 0.15 | | 0.157 |
| L | 0.4 | | 1.27 | 0.016 | | 0.050 |
| M | | | 0.6 | | | 0.024 |
| S | 8° (max.) | | | | | |

(1) D and F do not include mold flash or protrusions. Mold flash or protrusions shall not exceed 0.15mm (.006inch).

OUTLINE AND MECHANICAL DATA

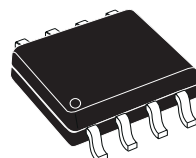

SO8

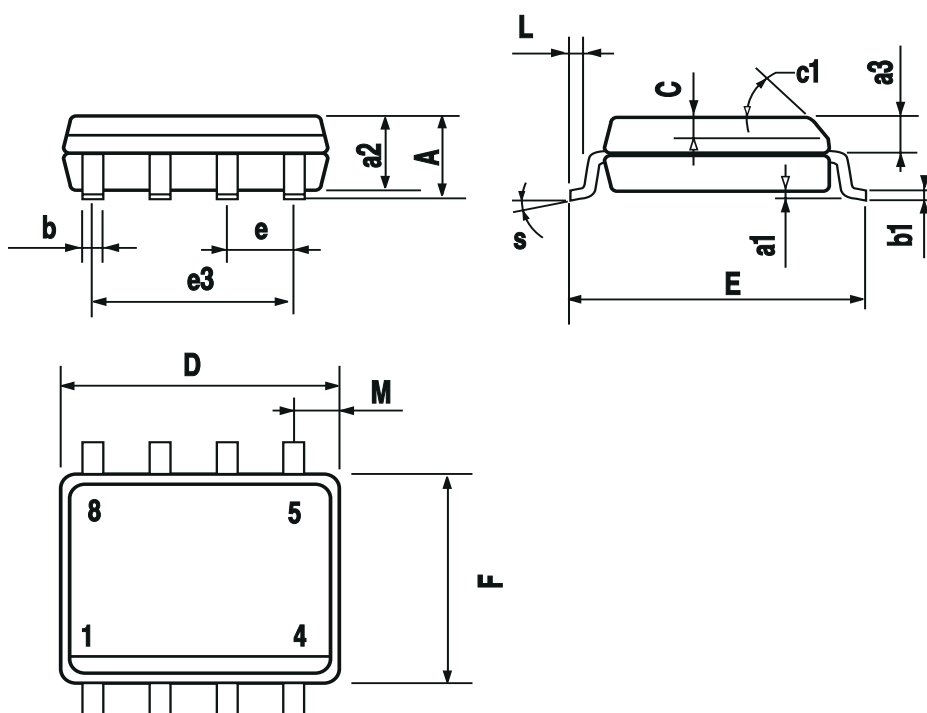

Information furnished is believed to be accurate and reliable. However, STMicroelectronics assumes no responsibility for the consequences of use of such information nor for any infringement of patents or other rights of third parties which may result from its use. No license is granted by implication or otherwise under any patent or patent rights of STMicroelectronics. Specifications mentioned in this publication are subject to change without notice. This publication supersedes and replaces all information previously supplied. STMicroelectronics products are not authorized for use as critical components in life support devices or systems without express written approval of STMicroelectronics.

The ST logo is a registered trademark of STMicroelectronics.
All other names are the property of their respective owners

© 2003 STMicroelectronics - All rights reserved

STMicroelectronics GROUP OF COMPANIES

Australia – Belgium - Brazil - Canada - China – Czech Republic - Finland - France - Germany - Hong Kong - India - Israel - Italy - Japan -
Malaysia - Malta - Morocco - Singapore - Spain - Sweden - Switzerland - United Kingdom - United States

www.st.com