

# Dual 14-Bit Rail-to-Rail DAC in 16-Lead SSOP Package

## FEATURES

- 14-Bit Monotonic Over Temperature
- Individually Programmable Speed/Power:
  - 3 $\mu$ s Settling Time at 930 $\mu$ A
  - 8.5 $\mu$ s Settling Time at 540 $\mu$ A
- 3V to 5V Single Supply Operation
- Maximum Update Rate: 0.9MHz
- Buffered True Rail-to-Rail Voltage Outputs
- User Selectable Gain
- Power-On Reset and Clear Function
- Schmitt Trigger On Clock Input Allows Direct Optocoupler Interface
- Smallest Dual 14-Bit DAC: 16-Lead Narrow SSOP Package

## APPLICATIONS

- Digital Calibration
- Industrial Process Control
- Automatic Test Equipment
- Offset/Gain Adjustment
- Multiplying DAC

## DESCRIPTION

The LTC<sup>®</sup>1654 is a dual, rail-to-rail voltage output, 14-bit digital-to-analog converter (DAC). It is available in a 16-lead narrow SSOP package, making it the smallest dual 14-bit DAC available. It includes output buffer amplifiers and a flexible serial interface.

The LTC1654 has REFHI pins for each DAC that can be driven up to  $V_{CC}$ . The output will swing from 0V to  $V_{CC}$  in a gain of 1 configuration or  $V_{CC}/2$  in a gain of 1/2 configuration. It operates from a single 2.7V to 5.5V supply.

The LTC1654 has two programmable speeds: a FAST and SLOW mode with  $\pm 1$ LSB settling times of 3 $\mu$ s or 8.5 $\mu$ s respectively and supply currents of 930 $\mu$ A and 540 $\mu$ A in the two modes. The LTC1654 also has shutdown capability, power-on reset and a clear function to 0V.

LT, LTC and LT are registered trademarks of Linear Technology Corporation. All other trademarks are the property of their respective owners. Protected by U.S. Patents, including 5396245.

## BLOCK DIAGRAM

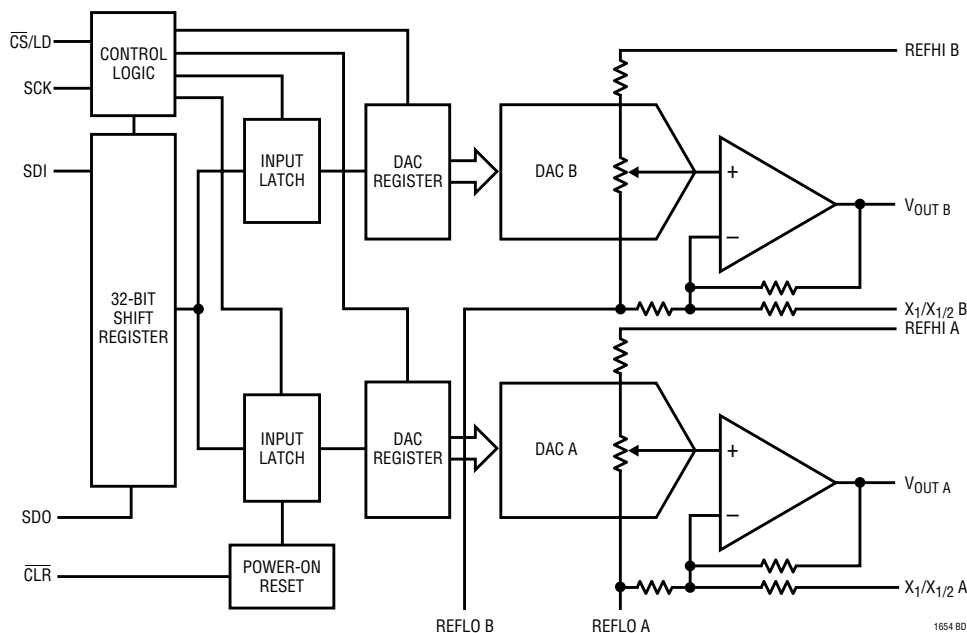

1654 BD

1654fb

## ABSOLUTE MAXIMUM RATINGS

(Note 1)

$V_{CC}$ to GND .....	-0.5V to 7.5V
TTL Input Voltage, REFHI, REFLO, $X_1/X_{1/2}$ .....	-0.5V to 7.5V
$V_{OUT}$ , SDO .....	-0.5V to ( $V_{CC} + 0.5V$ )
Operating Temperature Range	
LTC1654C .....	0°C to 70°C
LTC1654I .....	-40°C to 85°C
Maximum Junction Temperature .....	125°C
Storage Temperature Range .....	-65°C to 150°C
Lead Temperature (Soldering, 10 sec) .....	300°C

## PACKAGE/ORDER INFORMATION

<p>TOP VIEW</p> <p>GN PACKAGE 16-LEAD PLASTIC SSOP <math>T_{JMAX} = 125^{\circ}C</math>, <math>\theta_{JA} = 110^{\circ}C/W</math></p>	ORDER PART NUMBER
	LTC1654CGN LTC1654IGN
	GN PART MARKING
	1654 1654I

**Order Options** Tape and Reel: Add #TR  
Lead Free: Add #PBF Lead Free Tape and Reel: Add #TRPBF  
Lead Free Part Marking: <http://www.linear.com/leadfree/>

Consult LTC Marketing for parts specified with wider operating temperature ranges.

**ELECTRICAL CHARACTERISTICS** The ● denotes specifications which apply over the full operating temperature range, otherwise specifications are at  $T_A = 25^{\circ}C$ . Unless otherwise noted,  $V_{CC} = 2.7V$  to 5.5V,  $V_{OUT A}$ ,  $V_{OUT B}$  unloaded, REFHI A, REFHI B = 4.096V ( $V_{CC} = 5V$ ), REFHI A, REFHI B = 2.048V ( $V_{CC} = 2.7V$ ), REFLO = 0V,  $X_1/X_{1/2} = 0V$ .

SYMBOL	PARAMETER	CONDITIONS	MIN	TYP	MAX	UNITS
<b>DAC</b>						
n	Resolution		●	14		Bits
	Monotonicity		●	14		Bits
DNL	Differential Nonlinearity	Guaranteed Monotonic (Note 2)	●	±0.3	±1	LSB
INL	Integral Nonlinearity	Integral Nonlinearity (Note 2)	●	±1.2	±4	LSB
ZSE	Zero Scale Error	0°C ≤ $T_A$ ≤ 70°C -40°C ≤ $T_A$ ≤ 85°C	● ●	0	6.5 9.0	mV mV
$V_{OS}$	Offset Error	0°C ≤ $T_A$ ≤ 70°C (Note 3) -40°C ≤ $T_A$ ≤ 85°C (Note 3)	● ●		±6.5 ±9.0	mV mV
$V_{OSTC}$	Offset Error Tempco			±15		μV/°C
	Gain Error		●		±24	LSB
	Gain Error Drift			5		ppm/°C
<b>Power Supply</b>						
$V_{CC}$	Positive Supply Voltage	For Specified Performance	●	2.7	5.5	V
$I_{CC}$	Supply Current (SLOW/FAST)	2.7V ≤ $V_{CC}$ ≤ 5.5V (Note 5) SLOW 2.7V ≤ $V_{CC}$ ≤ 5.5V (Note 5) FAST 2.7V ≤ $V_{CC}$ ≤ 3.3V (Note 5) SLOW 2.7V ≤ $V_{CC}$ ≤ 3.3V (Note 5) FAST In Shutdown (Note 5)	● ● ● ● ●		540 850 930 1400 350 500 680 1000 3 10	μA μA μA μA μA μA
<b>Op Amp DC Performance</b>						
	Short-Circuit Current Low	$V_{OUT}$ Shorted to GND	●	70	120	mA
	Short-Circuit Current High	$V_{OUT}$ Shorted to $V_{CC}$	●	80	120	mA
	Output Impedance to GND	Input Code = 0	●	40	200	Ω
PSR	Power Supply Rejection	REFHIA, REFHIB = 4.096V ( $V_{CC} = 5V \pm 10\%$ ) REFHIA, REFHIB = 2.048V ( $V_{CC} = 3V \pm 10\%$ ) Input Code = 16383	●		2.5	mV/V

**ELECTRICAL CHARACTERISTICS** The ● denotes specifications which apply over the full operating temperature range, otherwise specifications are at  $T_A = 25^\circ\text{C}$ . Unless otherwise noted,  $V_{CC} = 2.7\text{V}$  to  $5.5\text{V}$ ,  $V_{OUT A}$ ,  $V_{OUT B}$  unloaded, REFHI A, REFHI B =  $4.096\text{V}$  ( $V_{CC} = 5\text{V}$ ), REFHI A, REFHI B =  $2.048\text{V}$  ( $V_{CC} = 2.7\text{V}$ ), REFLO =  $0\text{V}$ ,  $X_1/X_{1/2} = 0\text{V}$ .

SYMBOL	PARAMETER	CONDITIONS	MIN	TYP	MAX	UNITS
<b>AC Performance</b>						
	Voltage Output Slew Rate	(Note 8) SLOW (Note 8) FAST	● ●	0.20 1.25	0.9 3.8	$\text{V}/\mu\text{s}$ $\text{V}/\mu\text{s}$
	Voltage Output Settling Time	(Note 4) to $\pm 1\text{LSB}$ , SLOW (Note 4) to $\pm 1\text{LSB}$ , FAST			8.5 3.0	$\mu\text{s}$ $\mu\text{s}$
	Digital Feedthrough	(Note 7)		1		$\text{nV}\cdot\text{s}$
	Midscale Glitch Impulse	DAC Switch Between 8000 and 7FFF		20		$\text{nV}\cdot\text{s}$
	Output Noise Voltage Density	at 10kHz, SLOW at 10kHz, FAST		170 150		$\text{nV}/\sqrt{\text{Hz}}$ $\text{nV}/\sqrt{\text{Hz}}$

**Digital I/O**

$V_{IH}$	Digital Input High Voltage	$V_{CC} = 5\text{V}$	●	2.4		V
$V_{IL}$	Digital Input Low Voltage	$V_{CC} = 5\text{V}$	●		0.8	V
$V_{OH}$	Digital Output High Voltage	$V_{CC} = 5\text{V}$ , $I_{OUT} = -1\text{mA}$ , $D_{OUT}$ Only	●	$V_{CC} - 0.4$		V
$V_{OL}$	Digital Output Low Voltage	$V_{CC} = 5\text{V}$ , $I_{OUT} = 1\text{mA}$ , $D_{OUT}$ Only	●		0.4	V
$V_{IH}$	Digital Input High Voltage	$V_{CC} = 3\text{V}$	●	2.4		V
$V_{IL}$	Digital Input Low Voltage	$V_{CC} = 3\text{V}$	●		0.8	V
$V_{OH}$	Digital Output High Voltage	$V_{CC} = 3\text{V}$ , $I_{OUT} = -1\text{mA}$ , $D_{OUT}$ Only	●	$V_{CC} - 0.4$		V
$V_{OL}$	Digital Output Low Voltage	$V_{CC} = 3\text{V}$ , $I_{OUT} = 1\text{mA}$ , $D_{OUT}$ Only	●		0.4	V
$I_{LEAK}$	Digital Input Leakage	$V_{IN} = \text{GND}$ to $V_{CC}$	●		$\pm 10$	$\mu\text{A}$
$C_{IN}$	Digital Input Capacitance	(Note 6)			10	pF

**Reference Input**

	Reference Input Resistance	REFHI to REFLO	●	30	60	$\text{k}\Omega$
	Reference Input Range	(Note 6)	●	0	$V_{CC}$	V
	Reference Input Current	In Shutdown	●		1	$\mu\text{A}$

**Switching Characteristics ( $V_{CC} = 4.5\text{V}$  to  $5.5\text{V}$ )**

$t_1$	SDI Valid to SCK Setup		●	30		ns
$t_2$	SDI Valid to SCK Hold	(Note 6)	●	0		ns
$t_3$	SCK High Time	(Note 6)	●	15		ns
$t_4$	SCK Low Time	(Note 6)	●	15		ns
$t_5$	$\overline{\text{CS}}/\text{LD}$ Pulse Width	(Note 6)	●	15		ns
$t_6$	LSB SCK to $\overline{\text{CS}}/\text{LD}$	(Note 6)	●	10		ns
$t_7$	$\overline{\text{CS}}/\text{LD}$ Low to SCK	(Note 6)	●	10		ns
$t_8$	SDO Output Delay	$C_{LOAD} = 100\text{pF}$	●	5	100	ns
$t_9$	SCK Low to $\overline{\text{CS}}/\text{LD}$ Low	(Note 6)	●	10		ns
$t_{10}$	$\overline{\text{CLR}}$ Pulse Width	(Note 6)	●	30		ns

**Switching Characteristics ( $V_{CC} = 2.7\text{V}$  to  $5.5\text{V}$ )**

$t_1$	SDI Valid to SCK Setup		●	45		ns
$t_2$	SDI Valid to SCK Hold	(Note 6)	●	0		ns
$t_3$	SCK High Time	(Note 6)	●	20		ns
$t_4$	SCK Low Time	(Note 6)	●	20		ns
$t_5$	$\overline{\text{CS}}/\text{LD}$ Pulse Width	(Note 6)	●	20		ns
$t_6$	LSB SCK to $\overline{\text{CS}}/\text{LD}$	(Note 6)	●	15		ns
$t_7$	$\overline{\text{CS}}/\text{LD}$ Low to SCK	(Note 6)	●	15		ns

## ELECTRICAL CHARACTERISTICS

The ● denotes specifications which apply over the full operating temperature range, otherwise specifications are at  $T_A = 25^\circ\text{C}$ . Unless otherwise noted,  $V_{CC} = 2.7\text{V}$  to  $5.5\text{V}$ ,  $V_{OUT A}$ ,  $V_{OUT B}$  unloaded, REFHI A, REFHI B =  $4.096\text{V}$  ( $V_{CC} = 5\text{V}$ ), REFHI A, REFHI B =  $2.048\text{V}$  ( $V_{CC} = 2.7\text{V}$ ), REFLO =  $0\text{V}$ ,  $X_1/X_{1/2} = 0\text{V}$ .

SYMBOL	PARAMETER	CONDITIONS	MIN	TYP	MAX	UNITS
<b>Switching Characteristics (<math>V_{CC} = 2.7\text{V}</math> to <math>5.5\text{V}</math>)</b>						
$t_8$	SDO Output Delay	$C_{LOAD} = 100\text{pF}$	●	5	150	ns
$t_9$	SCK Low to $\overline{\text{CS/LD}}$ Low	(Note 6)	●	15		ns
$t_{10}$	$\overline{\text{CLR}}$ Pulse Width	(Note 6)	●	45		ns

**Note 1:** Absolute Maximum Ratings are those values beyond which the life of a device may be impaired.

**Note 2:** Nonlinearity is defined from low code  $k_L$  to code 16383. See Applications Information (page 11).

**Note 3:** Offset error is measured at low code  $k_L$ . See Applications Information (page 11).

**Note 4:** DAC switched between code 2  $k_L$  and code 16383. See Applications Information (page 11) for definition of low code  $k_L$ .

**Note 5:** Digital inputs at  $0\text{V}$  or  $V_{CC}$ .

**Note 6:** Guaranteed by design.

**Note 7:**  $\overline{\text{CS/LD}} = 0$ ,  $V_{OUT} = 4.096\text{V}$  and data is being clocked in.

**Note 8:**  $100\text{pF}$  load capacitor.

## TYPICAL PERFORMANCE CHARACTERISTICS

**Integral Nonlinearity (INL) vs Input Code**

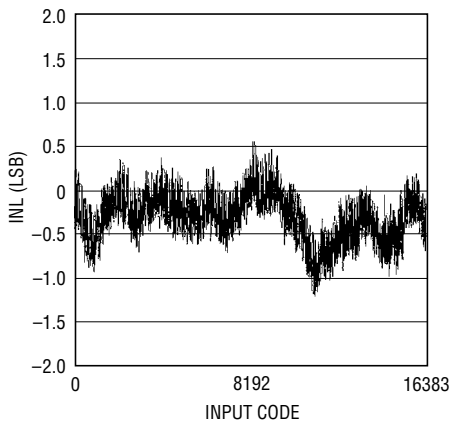

**Differential Nonlinearity (DNL) vs Input Code**

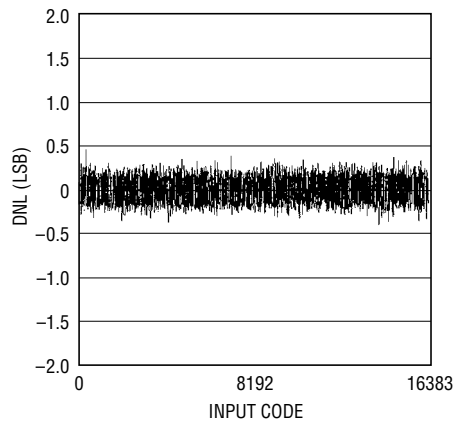

**Offset vs Temperature**

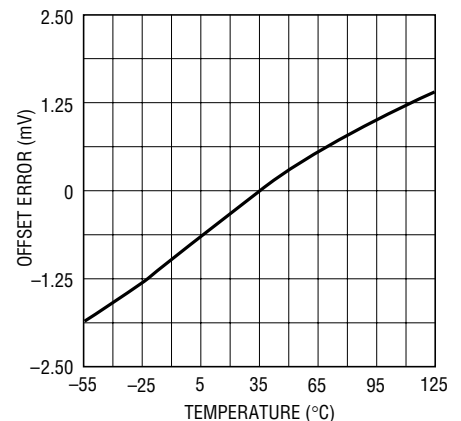

**Gain Error vs Temperature**

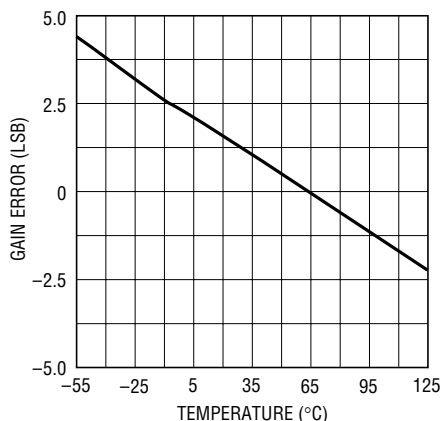

**Minimum Output Voltage vs Load Current (Output Sinking)**

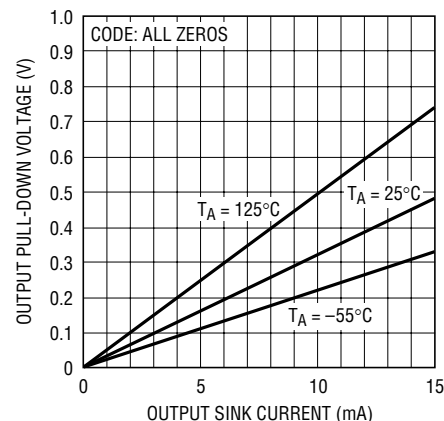

**Minimum Supply Headroom vs Load Current (Output Sourcing)**

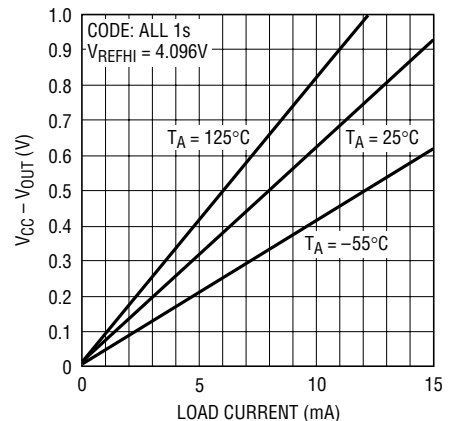

# TYPICAL PERFORMANCE CHARACTERISTICS

**Supply Current vs Logic Input Voltage**

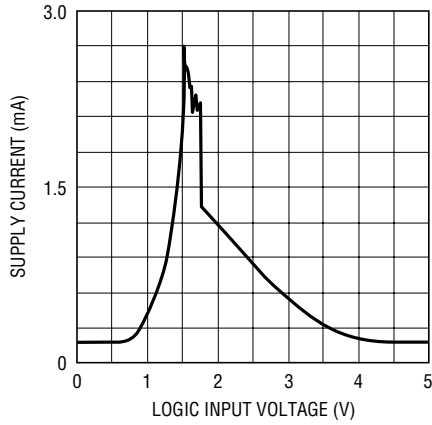

1654 G07

**Large-Signal Settling—Fast Mode**

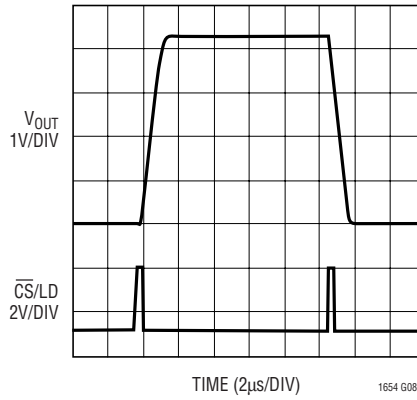

1654 G08

**Large-Signal Settling—Slow Mode**

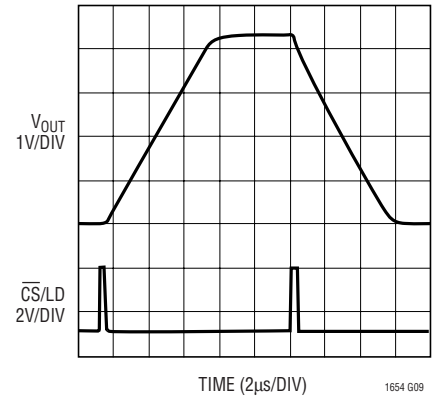

1654 G09

**Midscale Glitch—Fast Mode**

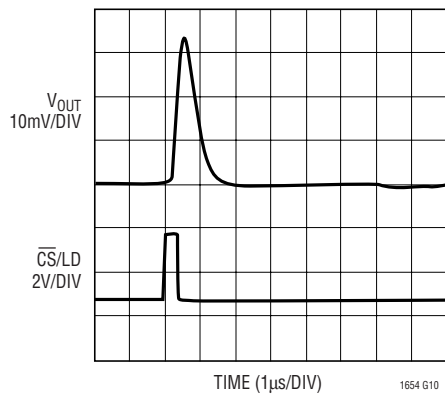

1654 G10

**Midscale Glitch—Slow Mode**

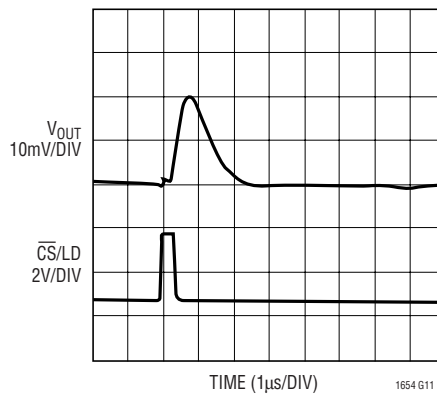

1654 G11

**VOUT Glitch at Power-Up**

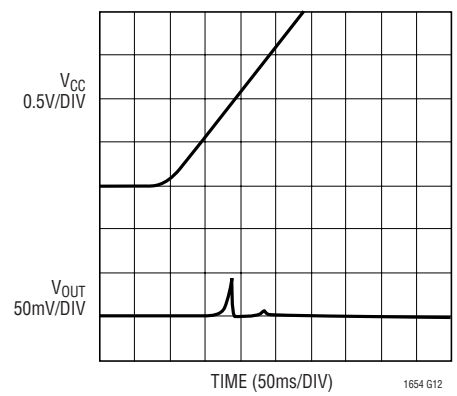

1654 G12

## PIN FUNCTIONS

**X<sub>1</sub>/X<sub>1/2</sub> B, X<sub>1</sub>/X<sub>1/2</sub> A (Pins 1, 8):** The Gain of 1 or Gain of 1/2 Pin. When this pin is tied to V<sub>OUT</sub>, the output range will be REFLO to (REFLO + REFHI)/2 (0V to REFHI/2 when REFLO = 0V). When this pin is tied to REFLO, the output range will be REFLO to REFHI (0V to REFHI when REFLO = 0V). These pins should not be left floating.

**CLR (Pin 2):** The Asynchronous Clear Input.

**SCK (Pin 3):** The TTL Level Input for the Serial Interface Clock.

**SDI (Pin 4):** The TTL Level Input for the Serial Interface Data. Data on the SDI pin is latched into the shift register on the rising edge of the serial clock. The LTC1654 allows either a 24-bit or 32-bit word. When a 24-bit word is used, the first 8 bits are control and address followed by 16 data bits. The last two of the 16 data bits are don't cares. When a 32-bit word (required for daisy-chain operation) is used, the first 8-bits are don't cares and the following 24-bits are as above.

**CS/LD (Pin 5):** The TTL Level Input for the Serial Interface Enable and Load Control. When CS/LD is low, the SCK signal is enabled, so the data can be clocked in. When CS/LD is pulled high, the control/address bits are decoded.

**DGND/AGND (Pins 6, 12):** Digital and Analog Grounds.

**SDO (Pin 7):** The output of the shift register that becomes valid on the rising edge of the serial clock.

**V<sub>OUT A/B</sub> (Pins 9, 15):** The Buffered DAC Outputs.

**REFHI A/B (Pins 10, 14):** The Reference High Inputs of the LTC1654. There is a gain of 1 from this pin to the output in a gain of 1 configuration. In a gain of 1/2 configuration, there is a gain of 1/2 from this pin to V<sub>OUT</sub>.

**REFLO A/B (Pins 11, 13):** The Reference Low Inputs of the LTC1654. These inputs can swing up to V<sub>CC</sub> – 1.5V.

**V<sub>CC</sub> (Pin 16):** The Positive Supply Input. 2.7V ≤ V<sub>CC</sub> ≤ 5.5V. Requires a 0.1μF bypass capacitor to ground.

## TIMING DIAGRAMS

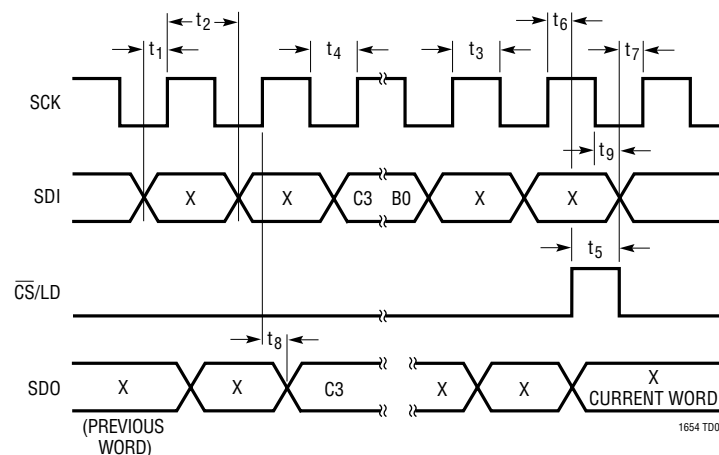

# TIMING DIAGRAMS

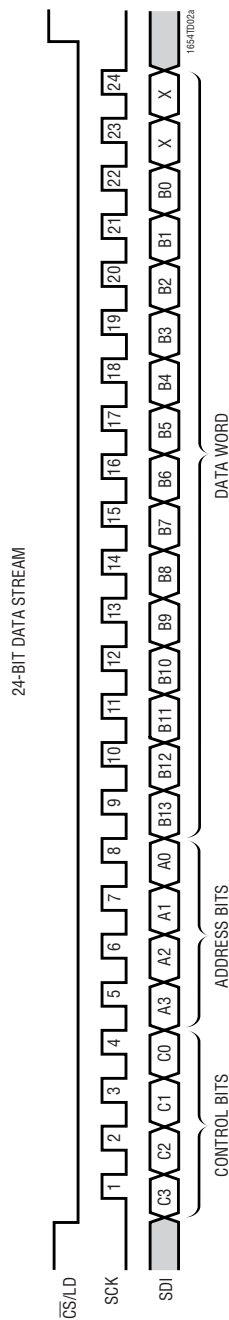

Figure 1a. 24-Bit Load Sequence (for Non-Daisy-Chained Applications)

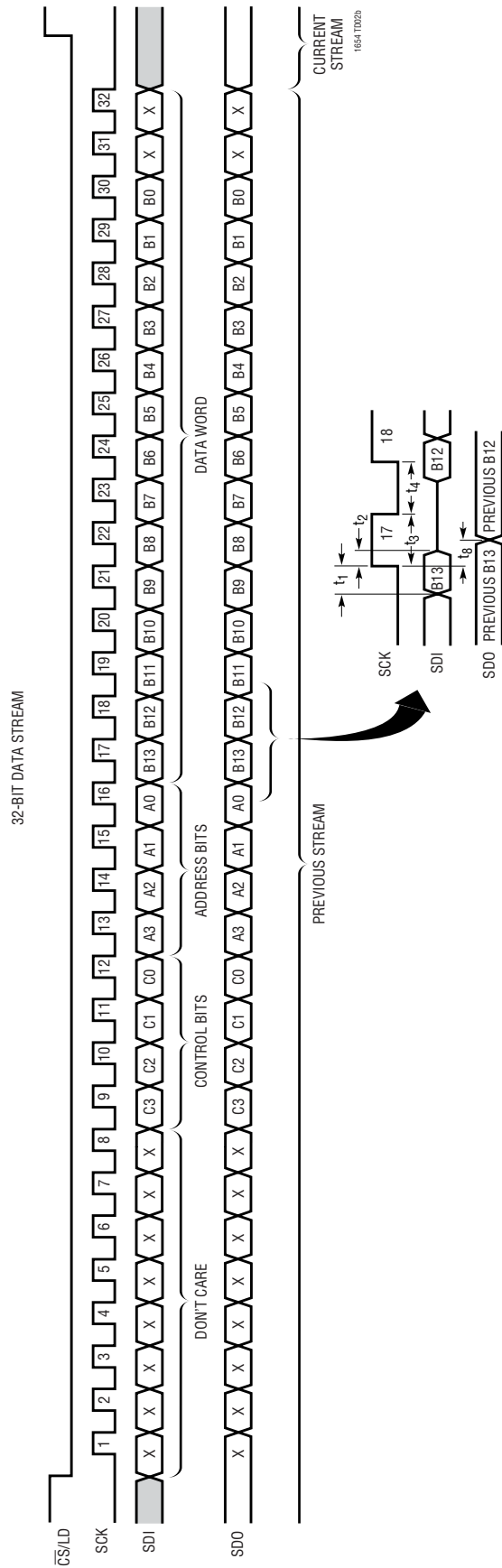

Figure 1b. 32-Bit Load Sequence (for Single and Daisy-Chained LTC1654s)

## OPERATION

### Serial Interface

The data on the SDI input is loaded into the shift register on the rising edge of SCK. The MSB is loaded first. The Clock is disabled internally when  $\overline{\text{CS/LD}}$  is high. Note: SCK must be low before  $\overline{\text{CS/LD}}$  is pulled low to avoid an extra internal clock pulse.

If no daisy-chaining is required, the input word can be 24-bit wide, as shown in the timing diagrams. The 8 MSBs, which are loaded first, are the control and address bits followed by a 16-bit data word. The last two LSBs in the data word are don't cares. The input word can be a stream of three 8-bit wide segments as shown in the "24-Bit Update" timing diagram.

If daisy-chaining is required or if the input needs to be written in two 16-bit wide segments, then the input word can be 32 bits wide and the top 8 bits (MSBs) are don't cares. The remaining 24 bits are control/address and data. This is also shown in the timing diagrams. The buffered output of the internal 32-bit shift register is available on the SDO pin, which swings from GND to  $V_{\text{CC}}$ .

Multiple LTC1654s may be daisy-chained together by connecting the SDO pin to the SDI pin of the next IC. The SCK and  $\overline{\text{CS/LD}}$  signals remain common to all ICs in the daisy-chain. The serial data is clocked to all of the chips, then the  $\overline{\text{CS/LD}}$  signal is pulled high to update all DACs simultaneously.

Table 1 shows the truth table for the control/address bits. When the supplies are first applied, the LTC1654 uses SLOW mode, the outputs are set at 0V, and zeros are loaded into the 32-bit input shift register. About 300ns after power-up, the outputs are released from 0V (AGND) and will go to the voltage on the REFLO pin.

When  $\overline{\text{CLR}}$  goes active, zeros are loaded into the input and DAC latch and the outputs are forced to AGND. After  $\overline{\text{CLR}}$  is forced high, the outputs will go to the voltage on the REFLO pin.

Three examples are given to illustrate the DAC's operation:

1. **Load and update DAC A in FAST mode. Leave DAC B unchanged.** Perform the following sequence for the control, address and DATA bits:

Step 1: Set DAC A in FAST mode

$\overline{\text{CS/LD}}$   $\downarrow$  clock in 0101 0000 XXXXXXXX XXXXXXXX;  
 $\overline{\text{CS/LD}}$   $\uparrow$

Step 2: Load and update DAC A with DATA

$\overline{\text{CS/LD}}$   $\downarrow$  clock in 0011 0000 + DATA;  $\overline{\text{CS/LD}}$   $\uparrow$

2. **Load and update DAC A in SLOW mode. Power down DAC B.** Perform the following sequence for the control, address and DATA bits:

Step 1: Set DAC A in SLOW mode

$\overline{\text{CS/LD}}$   $\downarrow$  clock in 0110 0000 XXXXXXXX  
XXXXXXXX;  
 $\overline{\text{CS/LD}}$   $\uparrow$

Step 2: Load and update DAC A with DATA

$\overline{\text{CS/LD}}$   $\downarrow$  clock in 0011 0000 + DATA;  $\overline{\text{CS/LD}}$   $\uparrow$

Step 3: Power down DAC B

$\overline{\text{CS/LD}}$   $\downarrow$  clock in 0100 0001 XXXXXXXX  
XXXXXXXX;  
 $\overline{\text{CS/LD}}$   $\uparrow$

3. **Power down both DACs at the same time.** Perform the following sequence for the control, address and DATA bits:

Step 1: Power down both DACs simultaneously

$\overline{\text{CS/LD}}$   $\downarrow$  clock in 0100 1111 XXXXXXXX  
XXXXXXXX;  
 $\overline{\text{CS/LD}}$   $\uparrow$



## OPERATION

### Voltage Output

The LTC1654 comes complete with rail-to-rail voltage output buffer amplifiers. These amplifiers will swing to within a few millivolts of either supply rail when unloaded and to within a 450mV of either supply rail when sinking or sourcing 5mA.

There are two GAIN configuration modes for the LTC1654:

- a) GAIN of 1: ( $X_1/X_{1/2}$  tied to REFLO)

$$V_{OUT} = (V_{REFHI} - V_{REFLO})(CODE/16384) + V_{REFLO}$$

- b) GAIN of 1/2: ( $X_1/X_{1/2}$  tied to  $V_{OUT}$ )

$$V_{OUT} = (1/2)(V_{REFHI} - V_{REFLO})(CODE/16384) + V_{REFLO}$$

The LTC 1654 has two SPEED modes: A FAST mode and a SLOW mode. When operating in the FAST mode, the output amplifiers will settle in 3 $\mu$ s (typ) to 14 bits on a 4V output swing. In the SLOW mode, they will settle in 8.5 $\mu$ s.

The total supply current is 930 $\mu$ A in the FAST mode and 540 $\mu$ A in the SLOW mode. The output noise voltage density at 10kHz is 170nV/ $\sqrt{\text{Hz}}$  in SLOW mode and 150nV/ $\sqrt{\text{Hz}}$  in FAST mode.

### Power Down

Each DAC can also be independently powered down to less than 5 $\mu$ A/DAC of supply current. The reference pin also goes into a high impedance state when the DAC is powered down and the reference current will drop to below 0.1 $\mu$ A. The amplifiers' output stage is also three-stated but the  $V_{OUT}$  pins still have the internal gain-setting resistors connected to them resulting in an effective resistance from  $V_{OUT}$  to REFLO. This resistance is typically 90k when the  $X_1/X_{1/2}$  pin is tied to  $V_{OUT}$  and 36k when  $X_1/X_{1/2}$  is tied to REFLO. Because of this resistance,  $V_{OUT}$  will go to  $V_{REFLO}$  when the DAC is powered down and  $V_{OUT}$  is unloaded.

## OPERATION

Table 1.

CONTROL				
C3	C2	C1	C0	
0	0	0	0	Load Input Register n
0	0	0	1	Update (Power-Up) DAC Register n
0	0	1	0	Load Input Register n, Update (Power-Up) All
0	0	1	1	Load and Update n
0	1	0	0	Power Down n
0	1	0	1	Fast n (Speed States are Maintained Even If DAC is Put in Power-Down Mode)
0	1	1	0	Slow n (Default State is Slow When Supplies are Powered Up)
0	1	1	1	Reserved (Do Not Use)
1	0	0	0	Reserved (Do Not Use)
1	0	0	1	Reserved (Do Not Use)
1	0	1	0	Reserved (Do Not Use)
1	0	1	1	Reserved (Do Not Use)
1	1	0	0	Reserved (Do Not Use)
1	1	0	1	Reserved (Do Not Use)
1	1	1	0	Reserved (Do Not Use)
1	1	1	1	No Operation

ADDRESS (n)				
A3	A2	A1	A0	
0	0	0	0	DAC A
0	0	0	1	DAC B
0	0	1	0	Reserved (Do Not Use)
0	0	1	1	Reserved (Do Not Use)
0	1	0	0	Reserved (Do Not Use)
0	1	0	1	Reserved (Do Not Use)
0	1	1	0	Reserved (Do Not Use)
0	1	1	1	Reserved (Do Not Use)
1	0	0	0	Reserved (Do Not Use)
1	0	0	1	Reserved (Do Not Use)
1	0	1	0	Reserved (Do Not Use)
1	0	1	1	Reserved (Do Not Use)
1	1	0	0	Reserved (Do Not Use)
1	1	0	1	Reserved (Do Not Use)
1	1	1	0	Reserved (Do Not Use)
1	1	1	1	Both DACs

### INPUT WORD

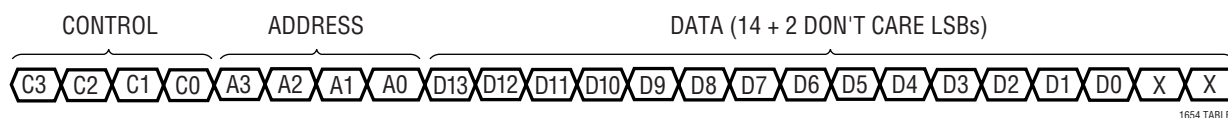

## APPLICATIONS INFORMATION

### Rail-to-Rail Output Considerations

Rail-to-rail DACs take full advantage of the supply range available to them, but cannot produce output voltages above  $V_{CC}$  or below ground. See Figure 2a.

If REFLO is tied to GND, the output for the lowest codes may limit at 0V, as shown in Figure 2b. Similarly, limiting can occur near full scale if the REFHI pin is tied to  $V_{CC}$ , as shown in Figure 2c.

The offset, gain error and linearity of the LTC1654 are defined and tested in output ranges that avoid limiting. The low code  $k_L$  used in these measurements is defined as the code which gives a nominal output of 32mV above ground; see Table 2.

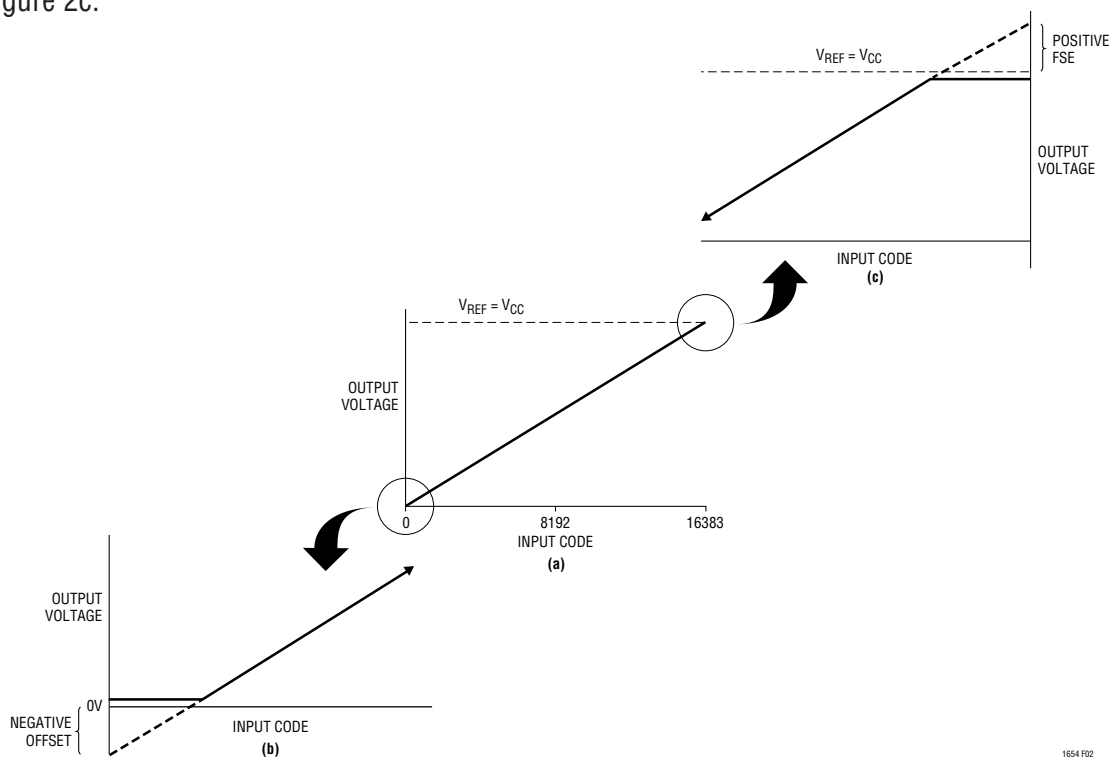

Figure 2. Effects of Rail-to-Rail Operation On a DAC Transfer Curve: (a) Overall Transfer Function, (b) Effect of Negative Offset for Codes Near Zero Scale, (c) Effect of Positive Full-Scale Error for Input Codes Near Full Scale When  $V_{REF} = V_{CC}$

Table 2. Low Code  $k_L$

GAIN	$V_{REFHI}, V$	
	4.096	2.048
1	128	256
1/2	256	512

Note:  $V_{REFLO} = 0$

## DEFINITIONS

**Resolution (n):** Resolution is defined as the number of digital input bits (n). It is also the number of DAC output states ( $2^n$ ) that divide the full-scale range. Resolution does not imply linearity.

**Full-Scale Voltage ( $V_{FS}$ ):** This is the output of the DAC when all bits are set to 1.

**Voltage Offset Error ( $V_{OS}$ ):** Normally, DAC offset is the voltage at the output when the DAC is loaded with all zeros. The DAC can have a true negative offset, but because the part is operated from a single supply, the output cannot go below 0V. If the offset is negative, the output will remain near 0V resulting in the transfer curve shown in Figure 3.

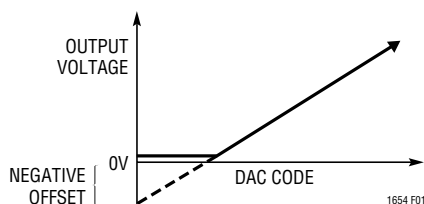

Figure 3. Effect of Negative Offset

Therefore, the offset of the part is measured at low code  $k_L$ :

$$V_{OS} = \frac{V_{OUT}(k_L) - \frac{(k_L)(V_{FS})}{2^n - 1}}{\left(1 - \frac{k_L}{2^n - 1}\right)}$$

**Least Significant Bit (LSB):** One LSB is the ideal voltage difference between two successive codes.

$$LSB = (V_{FS} - V_{OS}) / (2^n - 1) = (V_{FS} - V_{OS}) / 16383$$

Nominal LSBs:

$$LTC1654 \text{ LSB} = 4.09575V / 16383 = 250\mu V$$

**Zero-Scale Error (ZSE):** The output voltage when the DAC is loaded with all zeros. Since this is a single supply part, this value cannot be less than 0V.

**Integral Nonlinearity (INL):** End-point INL is the maximum deviation from a straight line passing through the end points of the DAC transfer curve. Because the part operates from a single supply and the output cannot go below zero, the linearity is measured between low code  $k_L$  and full scale. The INL error at a given input code is calculated as follows:

$$INL = [V_{OUT} - V_{OS} - (V_{FS} - V_{OS})(\text{code}/16383)] / LSB$$

$V_{OUT}$  = The output voltage of the DAC measured at the given input code

**Differential Nonlinearity (DNL):** DNL is the difference between the measured change and the ideal one LSB change between any two adjacent codes. The DNL error between any two codes is calculated as follows:

$$DNL = (\Delta V_{OUT} - LSB) / LSB$$

$\Delta V_{OUT}$  = The measured voltage difference between two adjacent codes

**Digital Feedthrough:** The glitch that appears at the analog output caused by AC coupling from the digital inputs when they change state. The area of the glitch is specified in  $nV \cdot s$ .

## TYPICAL APPLICATIONS

This circuit shows how to use an LTC1654 and an LT<sup>®</sup>1077 to make a wide bipolar output swing 14-bit DAC with an offset that can be digitally programmed.  $V_{OUTA}$ , which can be set by loading the appropriate code for DAC A, sets the

offset. As this value changes, the transfer curve for the output moves up and down as illustrated in the graph below.

A Wide Swing, Bipolar Output 14-Bit DAC with Digitally Controlled Offset

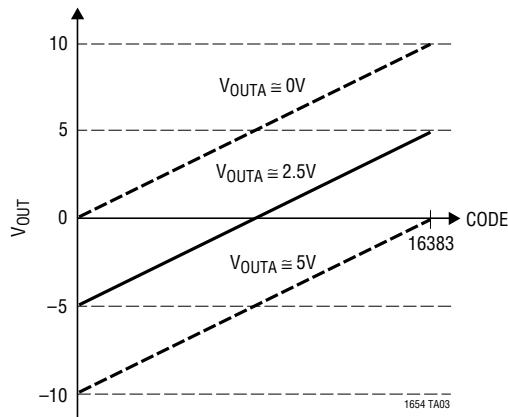
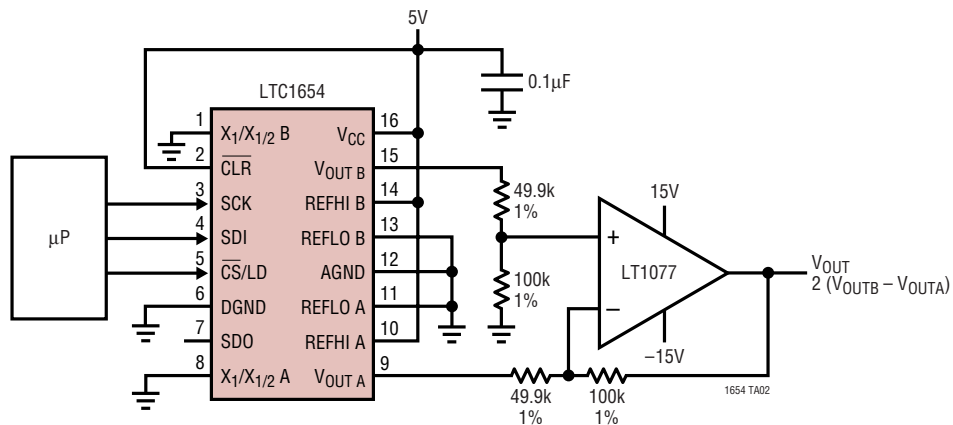

**TYPICAL APPLICATIONS**

**Dual 14-Bit Voltage Output DAC**

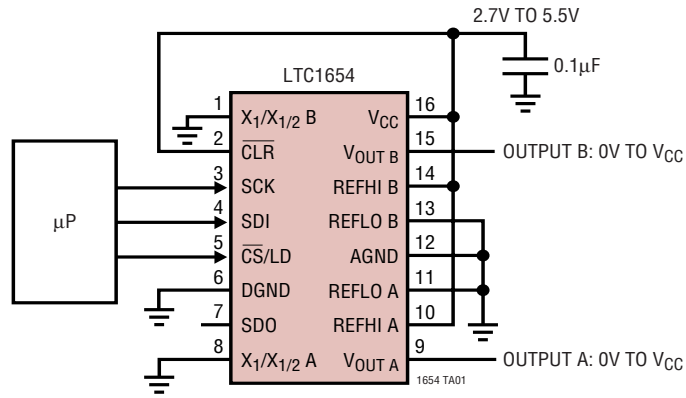

# PACKAGE DESCRIPTION

**GN Package**  
**16-Lead Plastic SSOP (Narrow .150 Inch)**  
 (Reference LTC DWG # 05-08-1641)

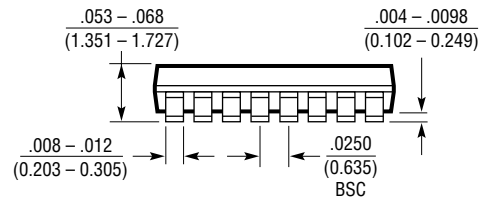
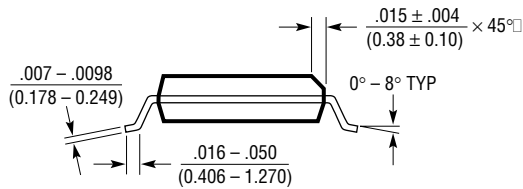
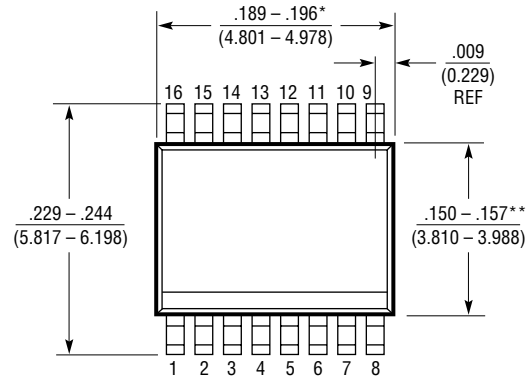
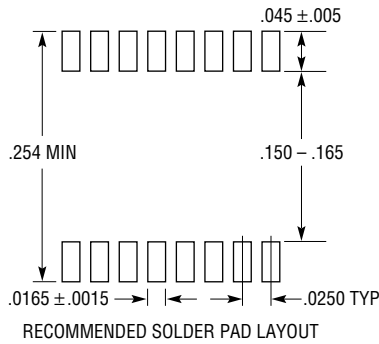

**NOTE:**

1. CONTROLLING DIMENSION: INCHES
2. DIMENSIONS ARE IN  $\frac{\text{INCHES}}{\text{MILLIMETERS}}$
3. DRAWING NOT TO SCALE

\*DIMENSION DOES NOT INCLUDE MOLD FLASH. MOLD FLASH SHALL NOT EXCEED 0.006" (0.152mm) PER SIDE

\*\*DIMENSION DOES NOT INCLUDE INTERLEAD FLASH. INTERLEAD FLASH SHALL NOT EXCEED 0.010" (0.254mm) PER SIDE

GN16 (SSOP) 0502

## TYPICAL APPLICATION

### A Wide Swing, Bipolar Output 14-Bit DAC with Digitally Controlled Offset

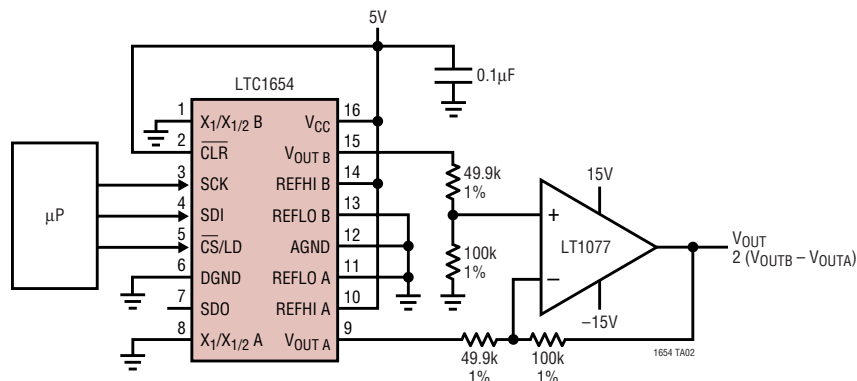

## RELATED PARTS

PART NUMBER	DESCRIPTION	COMMENTS
LTC1257	Single 12-Bit $V_{OUT}$ DAC, Full Scale: 2.048V, $V_{CC}$ : 4.75V to 15.75V, Reference Can Be Overdriven Up to 12V, i.e., $FS_{MAX} = 12V$	5V to 15V Single Supply, Complete $V_{OUT}$ DAC in SO-8 Package
LTC1446/LTC1446L	Dual 12-Bit $V_{OUT}$ DACs in SO-8 Package	LTC1446: $V_{CC} = 4.5V$ to 5.5V, $V_{OUT} = 0V$ to 4.095V LTC1446L: $V_{CC} = 2.7V$ to 5.5V, $V_{OUT} = 0V$ to 2.5V
LTC1448	Dual 12-Bit $V_{OUT}$ DAC, $V_{CC}$ : 2.7V to 5.5V	Output Swings from GND to REF. REF Input Can Be Tied to $V_{CC}$
LTC1450/LTC1450L	Single 12-Bit $V_{OUT}$ DACs with Parallel Interface	LTC1450: $V_{CC} = 4.5V$ to 5.5V, $V_{OUT} = 0V$ to 4.095V LTC1450L: $V_{CC} = 2.7V$ to 5.5V, $V_{OUT} = 0V$ to 2.5V
LTC1451	Single Rail-to-Rail 12-Bit DAC, Full Scale: 4.095V, $V_{CC}$ : 4.5V to 5.5V, Internal 2.048V Reference Brought Out to Pin	5V, Low Power Complete $V_{OUT}$ DAC in SO-8 Package
LTC1452	Single Rail-to-Rail 12-Bit $V_{OUT}$ Multiplying DAC, $V_{CC}$ : 2.7V to 5.5V	Low Power, Multiplying $V_{OUT}$ DAC with Rail-to-Rail Buffer Amplifier in SO-8 Package
LTC1453	Single Rail-to-Rail 12-Bit $V_{OUT}$ DAC, Full Scale: 2.5V, $V_{CC}$ : 2.7V to 5.5V	3V, Low Power, Complete $V_{OUT}$ DAC in SO-8 Package
LTC1454/LTC1454L	Dual 12-Bit $V_{OUT}$ DACs in SO-16 Package with Added Functionality	LTC1454: $V_{CC} = 4.5V$ to 5.5V, $V_{OUT} = 0V$ to 4.095V LTC1454L: $V_{CC} = 2.7V$ to 5.5V, $V_{OUT} = 0V$ to 2.5V
LTC1456	Single Rail-to-Rail Output 12-Bit DAC with Clear Pin, Full Scale: 4.095V, $V_{CC}$ : 4.5V to 5.5V	Low Power, Complete $V_{OUT}$ DAC in SO-8 Package with Clear Pin
LTC1458/LTC1458L	Quad 12 Bit Rail-to-Rail Output DACs with Added Functionality	LTC1458: $V_{CC} = 4.5V$ to 5.5V, $V_{OUT} = 0V$ to 4.095V LTC1458L: $V_{CC} = 2.7V$ to 5.5V, $V_{OUT} = 0V$ to 2.5V
LTC1658	14-Bit Rail-to-Rail Micropower DAC in MSOP, $V_{CC}$ : 2.7V to 5.5V	Output Swings from GND to REF. REF Input Can Be Tied to $V_{CC}$
LTC1659	Single Rail-to-Rail 12-Bit $V_{OUT}$ DAC in 8-Pin MSOP, $V_{CC}$ : 2.7V to 5.5V	Low Power, Multiplying $V_{OUT}$ DAC in MS8 Package. Output Swings from GND to REF. REF Input Can Be Tied to $V_{CC}$

### References

LT1460	Micropower Precision Reference	Low Cost, 10ppm Drift
LT1461	Precision Voltage Reference	Ultralow Drift 3ppm/°C, Initial Accuracy: 0.04%
LT1634	Micropower Precision Reference	Low Drift 10ppm/°C, Initial Accuracy: 0.05%