

Thermocouple Cold Junction Compensator and Matched Amplifier

FEATURES

- 0.75°C Initial Accuracy (A Version)
- Extremely Low Warmup Drift
- Preset Outputs for Type E, J, K, R, S, T
- Single 5V to ±20V Operation
- 480µA Typical Supply Current
- Available in 8-Pin DIP Package

APPLICATIONS

- Thermocouple Cold Junction Compensation

DESCRIPTION

The LTK001 is a thermocouple amplifier supplied with a matched cold junction compensator. By separating the amplifier and compensator functions, the problem of compensator temperature rise is virtually eliminated. The compensator is a selected version of the LT[®]1025 cold junction compensator. The amplifier, which is also available separately as LTKA0x has been specially selected for

thermocouple applications. It has low supply current to minimize warmup drift, very low offset voltage (<35µV), high gain, and extremely low input bias currents (<600pA) to allow high impedance input filters to be used without degrading offset voltage or drift.

Matching of the kits is accomplished by separating the compensators and amplifiers according to the polarity of their initial (room temperature) errors. This eliminates the need to sum the errors of the two components to find the worst-case error.

The LTK001 has direct thermocouple outputs of 60.9µV/°C (E), 51.7µV/°C (J), 40.6µV/°C (K, T), and 5.95µV/°C (R, S). It also has a 10mV/°C output which can be scaled to match any arbitrary thermocouple.

For multiple thermocouple applications using one compensator, amplifiers may be ordered separately (LTKA0x), still matched to the compensator.

LT, LTC and LT are registered trademarks of Linear Technology Corporation. All other trademarks are the property of their respective owners. For typical performance curves and applications circuits consult the LT1025 data sheet.

TYPICAL APPLICATION

Type K 10mV/°C Thermometer

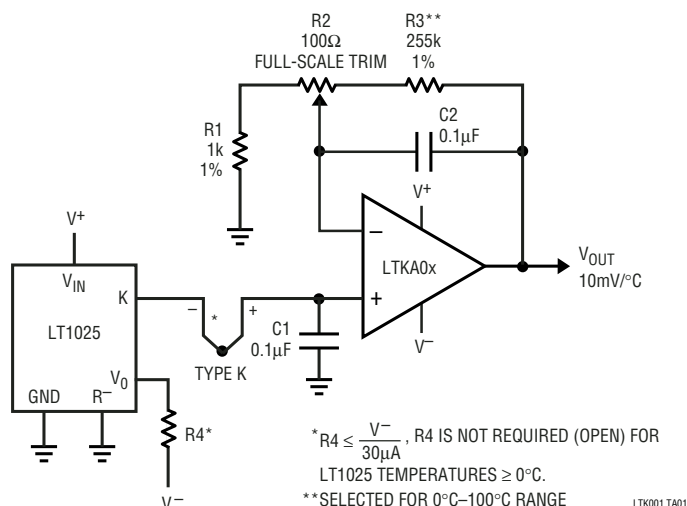

ABSOLUTE MAXIMUM RATINGS (Note 1)

Amplifier (LTKA0x)

Supply Voltage (Total V^+ to V^-) 40V
 Differential Input Current (Note 2) $\pm 10\text{mA}$
 Common Mode Input Voltage Equal to Supplies
 Output Short-Circuit Duration Indefinite

Compensator (LT1025)

Supply Voltage (V_{IN} to Ground Pin) 36V
 Output Voltage (Forced) 5V
 Output Short-Circuit Duration Indefinite

Both Devices

Operating Temperature Range

LTK001AMJ8, LTK001MJ8 (**OBSOLETE**)

..... -55°C to 125°C

LTK001ACN8, LTK001CN8 0°C to 70°C

Storage Temperature Range -65°C to 150°C

Lead Temperature Range (Soldering, 10 sec.) 300°C

PACKAGE/ORDER INFORMATION

<p>TOP VIEW</p> <p>N8 PACKAGE 8-LEAD PDIP COMPENSATOR (LT1025)</p> <p>$T_{JMAX} = 100^\circ\text{C}$, $\theta_{JA} = 130^\circ\text{C/W}$ (N8)</p>	<p>TOP VIEW</p> <p>N8 PACKAGE 8-LEAD PDIP AMPLIFIER (LTKA0x)</p> <p>$T_{JMAX} = 100^\circ\text{C}$, $\theta_{JA} = 130^\circ\text{C/W}$</p>	<p>TOP VIEW VOS TRIM</p> <p>H PACKAGE 8-LEAD TO-5 METAL CAN AMPLIFIER (LTKA0x)</p> <p>$T_{JMAX} = 150^\circ\text{C}$, $\theta_{JA} = 150^\circ\text{C/W}$, $\theta_{JC} = 45^\circ\text{C/W}$</p>
<p>ORDER PART NUMBER</p>	<p>ORDER PART NUMBER</p>	<p>ORDER PART NUMBER</p>
<p>KIT</p> <p>LTK001CN8 LTK001ACN8</p> <hr/> <p>J8 PACKAGE 8-LEAD CERDIP COMPENSATOR (LT1025)</p> <p>$T_{JMAX} = 150^\circ\text{C}$, $\theta_{JA} = 100^\circ\text{C/W}$ (J8)</p> <p>LTK001MJ8 LTK001AMJ8</p> <p>OBSOLETE PACKAGE</p> <p>Consider the N8 Package for Alternate Source</p>	<p>AMPLIFIER ONLY (Note A)</p> <p>LTKA00CN8 LTKA01CN8</p>	<p>AMPLIFIER ONLY (Note A)</p> <p>LTKA00MH LTKA01MH</p> <p>OBSOLETE PACKAGE</p>

Note A: The polarity of the amplifier is indicated by the 0 or 1 in the part number. An LT1025 with a 0 identifier is properly matched with an LTKA00, while an LT1025 with a 1 identifier should be used with an LTKA01.

Consult factory for parts specified with wider operating temperature ranges.

ELECTRICAL CHARACTERISTICS (Matched Amplifier and Compensator) $T_A = 25^\circ\text{C}$, $V_S = \pm 15\text{V}$ (Amplifier), $V_S = 5\text{V}$ (Compensator)

PARAMETER	CONDITIONS		LTK001A			LTK001			UNITS
			MIN	TYP	MAX	MIN	TYP	MAX	
Total Temperature Error at 25°C (Note 3)		Type E			0.75			2.5	°C
		Type J			0.75			2.5	°C
		Type K, T			0.86			2.5	°C
		Type R, S	(Note 12)		5.0			5.0	°C
Slope Error (Notes 4 and 9)	$0^\circ\text{C} \leq T_J \leq 70^\circ\text{C}$	Type E			0.05			0.09	°C/°C
		Type J			0.06			0.09	°C/°C
		Type K, T			0.07			0.10	°C/°C
		Type R, S			0.28			0.32	°C/°C
Total Temperature Error at Temperature Extremes (Note 9)	$0^\circ\text{C} \leq T_J \leq 70^\circ\text{C}$	Type E			2.0			5	°C
		Type J			2.1			5	°C
		Type K, T			2.6			5.2	°C
		Type R, S	(Note 12)		16			16	°C
	$-55^\circ\text{C} \leq T_J \leq 125^\circ\text{C}$	Type E			6			8.5	°C
		Type J			6			8.5	°C
		Type K, T			6.3			9	°C
		Type R, S	(Note 12)		30			30	°C
Temperature Error Change with Supply Voltage (Note 5)				0.1			0.1	°C/V	
Supply Current				480	900		480	900	μA

ELECTRICAL CHARACTERISTICS (Compensator LT1025)

The ● denotes the specifications which apply over the full operating temperature range, otherwise specifications are at $T_A = 25^\circ\text{C}$. $V_S = 5\text{V}$ unless otherwise noted.

PARAMETER	CONDITIONS	COMPENSATOR (LT1025)			UNITS
		MIN	TYP	MAX	
Temperature Error at 10mV/°C Output (Note 9)	$T_J = 25^\circ\text{C}$, LTK001A		0.3	0.5	°C
	$T_J = 25^\circ\text{C}$, LTK001		0.5	2.0	°C
	Full Temperature Span	●	See Curve on LT1025 Data Sheet		
Temperature Error at Individual Outputs (Note 10)	LTK001A: E, J, K, T		0.4	0.75	°C
	LTK001A: R, S		0.4	1.5	°C
	LTK001: E, J, K, T		0.8	2.4	°C
	LTK001: R, S		1.2	3.5	°C
	Full Temperature Span	●	See Curve on LT1025 Data Sheet		
Supply Current	$4\text{V} \leq V_{IN} \leq 36\text{V}$		80	100	μA
	$0^\circ\text{C} \leq T_J \leq 70^\circ\text{C}$	●		150	μA
	$-55^\circ\text{C} \leq T_J \leq 125^\circ\text{C}$	●		200	μA
Change in Supply Current	$4\text{V} \leq V_{IN} \leq 36\text{V}$		0.01	0.05	$\mu\text{A/V}$
Line Regulation (Note 11)	$4\text{V} \leq V_{IN} \leq 36\text{V}$ 10mV/°C Output	●	0.003	0.02	°C/V
Load Regulation (Note 11)	$0 \leq I_O \leq 1\text{mA}$ 10mV/°C Output	●	0.04	0.2	°C
Divider Impedance	E		2.5		k Ω
	J		2.1		k Ω
	K, T		4.4		k Ω
	R, S		3.8		k Ω

ELECTRICAL CHARACTERISTICS (Amplifier LTKA0x)

The ● denotes the specifications which apply over the full operating temperature range, otherwise specifications are at $T_A = 25^\circ\text{C}$. $V_S = \pm 15\text{V}$, $V_{CM} = 0\text{V}$, $T_J = 25^\circ\text{C}$ unless otherwise noted.

PARAMETER	CONDITIONS	AMPLIFIER (LTKA0x)			UNITS
		MIN	TYP	MAX	
Input Offset Voltage			10	35	μV
Input Offset Voltage Drift with Temperature	(Note 6)	●	0.3	1.5	$\mu\text{V}/^\circ\text{C}$
Input Bias Current	$0^\circ\text{C} \leq T_A \leq 70^\circ\text{C}$ $-55^\circ\text{C} \leq T_A \leq 125^\circ\text{C}$	● ●	± 200 ± 300	± 600 ± 1500	pA pA
Input Bias Current Drift with Temperature	(Note 6)		1	5	$\text{pA}/^\circ\text{C}$
Input Offset Current	$0^\circ\text{C} \leq T_A \leq 70^\circ\text{C}$ $-55^\circ\text{C} \leq T_A \leq 125^\circ\text{C}$	● ●	± 100 ± 200	± 500 ± 700	pA pA
Input Offset Current Drift with Temperature	(Note 6)	●	0.6	4	$\text{pA}/^\circ\text{C}$
Large Signal Voltage Gain	$R_L = 10\text{k}\Omega$	●	400	2000	V/mV
Common Mode Rejection Ratio	$V_{CM} = \pm 13.5\text{V}$	●	106	130	dB
Power Supply Rejection Ratio	$\pm 2.5\text{V} \leq V_S \leq \pm 20\text{V}$ (Note 5)	●	106	125	dB
Common Mode Input Voltage Range	Notes 6, 7	Above V^-	0.75		V
		Below V^+		1.0	V
Output Voltage Swing (Notes 6, 8)	Referred to Supplies	$I_{OUT} = 0.1\text{mA}$		0.8	V
		$I_{OUT} = 1\text{mA}$		1.1	V
Supply Current		●	400	800	μA
Supply Voltage Range	Total V^+ to V^- Voltage	●	4.5	40	V

Note 1: Absolute Maximum Ratings are those values beyond which the life of a device may be impaired.

Note 2: The inputs of the LTKA0x amplifier are clamped with diodes, so a differential voltage rating does not apply.

Note 3: Total temperature error is the overall error at 25°C taking into account the offset of the amplifier, the offset at the compensator $10\text{mV}/^\circ\text{C}$ output, and the error in the compensator divider network. Warmup drift is not included.

Note 4: Slope error is the increase in total temperature error as ambient temperature is increased. It is guaranteed by design and by other tests, but is not tested directly.

Note 5: This is a worst-case limit assuming that any or all supply voltages change.

Note 6: Guaranteed, but not tested.

Note 7: By referring common mode range to the supplies, the range referred to ground can be quickly calculated for any given supply voltage. With a single 5V supply, for instance, which has a worst-case low value of 4.7V , the upper common mode limit is $4.7\text{V} - 1\text{V} = 3.7\text{V}$. The lower common mode limit is $0\text{V} + 0.75\text{V} = 0.75\text{V}$. With $\pm 15\text{V}$ supplies, the limits would be 14V and -14.25V , respectively. Common mode range has a temperature sensitivity of $\approx 2\text{mV}/^\circ\text{C}$.

Note 8: Absolute output voltage swing is calculated by subtracting the given limits from actual supply voltage. These limits indicate the point where offset voltage has changed suddenly by $5\mu\text{V}$.

Note 9: Temperature error is defined as the deviation from the following formula:

$$V_{OUT} = \alpha(T) + \alpha\beta(T - 25^\circ\text{C})^2$$

α = Typical thermocouple Seebeck coefficient as follows,

E = $60.9\mu\text{V}/^\circ\text{C}$, J = $51.7\mu\text{V}/^\circ\text{C}$, K, T = $40.6\mu\text{V}/^\circ\text{C}$, R, S = $5.95\mu\text{V}/^\circ\text{C}$.

α = $10\text{mV}/^\circ\text{C}$ at the 10mV output.

β = Nonlinearity coefficient built into the LT1025 to help compensate for the nonlinearities of thermocouples. $\beta = 5.5 \times 10^{-4}$, generating 0.34°C bow for 25°C temperature change, and 1.36°C bow for 50°C change.

Note 10: Temperature error at the individual outputs is the sum of the $10\text{mV}/^\circ\text{C}$ output error plus the resistor divider error.

Note 11: Line and load regulation do not take into account the effects of self-heating. Output changes due to self-heating can be calculated as follows:

$$\Delta V_{OUT} (\text{Line}) = \Delta V_{IN}(I_Q + I_{load})(150^\circ\text{C}/\text{W})$$

$$\Delta V_{OUT} (\text{Load}) = (\Delta I_{load})(V_{IN})(150^\circ\text{C}/\text{W}) \\ = \text{LT1025 supply current}$$

Load regulation is $30\mu\text{A} \leq I_O \leq 1\text{mA}$ for $T_A \leq 0^\circ\text{C}$.

Note 12: Larger errors with type R and S thermocouples are due mostly to $35\mu\text{V}$ offset of the amplifier. This error can be reduced to $5\mu\text{V}$ max with the LTC[®]1050 or LTC1052 operational amplifiers.

PACKAGE DESCRIPTION

H Package
8-Lead TO-5 Metal Can (.200 Inch PCD)
 (Reference LTC DWG # 05-08-1320)

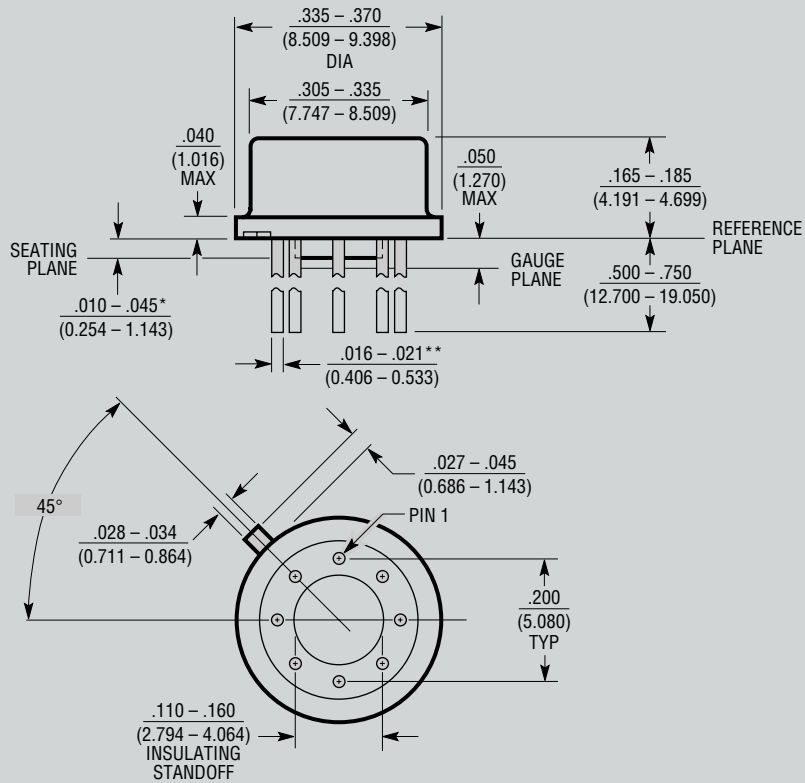

* LEAD DIAMETER IS UNCONTROLLED BETWEEN THE REFERENCE PLANE AND THE SEATING PLANE
 ** FOR SOLDER DIP LEAD FINISH, LEAD DIAMETER IS $.016 - .024$ (0.406 - 0.610) H8(TO-5) 0.200 PCD 0204

OBsolete PACKAGE

PACKAGE DESCRIPTION

J8 Package 8-Lead Cerdip (Narrow .300 Inch, Hermetic) (Reference LTC DWG # 05-08-1110)

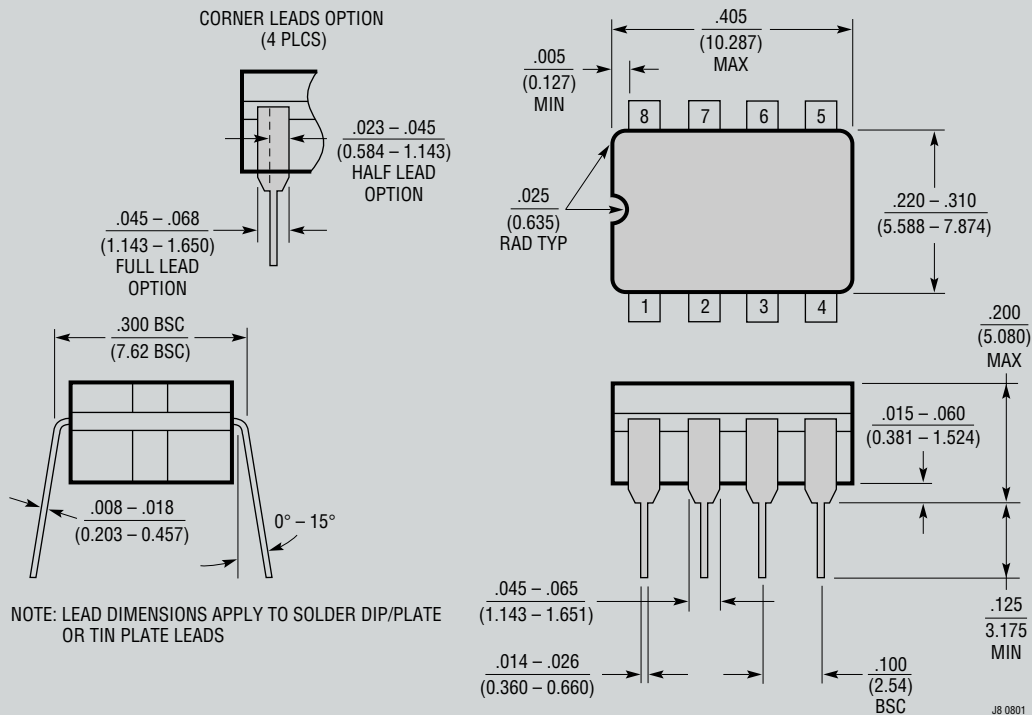

OBSOLETE PACKAGE

PACKAGE DESCRIPTION

N8 Package 8-Lead PDIP (Narrow .300 Inch) (Reference LTC DWG # 05-08-1510)

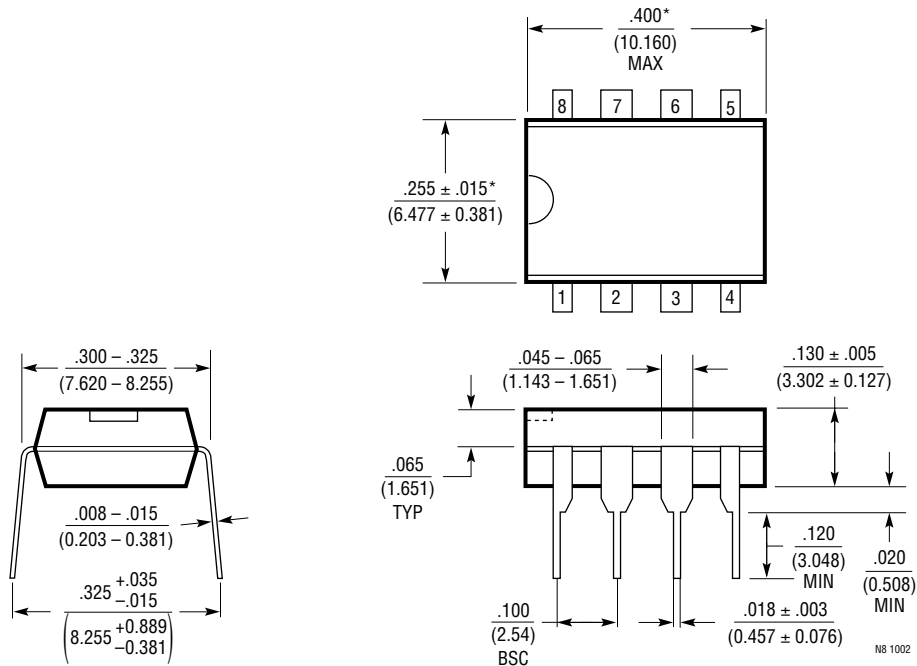

NOTE:
1. DIMENSIONS ARE $\frac{\text{INCHES}}{\text{MILLIMETERS}}$
*THESE DIMENSIONS DO NOT INCLUDE MOLD FLASH OR PROTRUSIONS.
MOLD FLASH OR PROTRUSIONS SHALL NOT EXCEED .010 INCH (0.254mm)

RELATED PARTS

PART NUMBER	DESCRIPTION	COMMENTS
LT1012	Picoamp Input Current Amplifier	$V_{OS} = 120\mu\text{V MAX}$, $I_{OS} = 280\text{pA MAX}$
LT1025	Thermocouple Cold Junction Comparator	Micropower, 0.5°C Initial Accuracy
LTC1050	Zero Drift Amplifier	$V_{OS} = 5\mu\text{V MAX}$, $A_{VOL} = 1\text{V}/\mu\text{V MAX}$
LTC2050	SOT-23 Zero Drift Amplifier	$V_{OS} = 3\mu\text{V MAX}$