



±70V Fault-Protected, 3.0V to 5.5V, 2Tx/2Rx RS-232 Transceiver

General Description

The MAX13223E is a +3.0V to +5.5V-powered EIA/TIA-232 and V.28 communications interface with fault protection on the RS-232 line interface. This allows shorts of the transmitter outputs and receiver inputs to voltages in the ±70V range without adversely affecting the MAX13223E.

The MAX13223E achieves 1μA supply current using Maxim's AutoShutdown™ feature. The MAX13223E automatically enters a low-power shutdown mode when the RS-232 cable is disconnected or the receivers are inactive. The device turns on again when a valid transition at any receiver input is sensed. A proprietary, high-efficiency, dual charge-pump power supply and a low-dropout transmitter combine to deliver true RS-232 performance from a single +3.0V to +5.5V supply.

The MAX13223E has two receivers and two drivers and is guaranteed to run at data rates of 250kbps for one transmitter switching while maintaining RS-232 output levels.

The MAX13223E operates from input voltages ranging from +3.0V to +5.5V and is available in a 20-pin, 6.5mm x 4.4mm, TSSOP package. The MAX13223E is specified over the -40°C to +85°C temperature range.

Applications

Automotive
Telematics Equipment
Base Stations
Utility Meters
Industrial Equipment
Telecomm Equipment
POS Terminal Equipment

AutoShutdown is a trademark of Maxim Integrated Products, Inc.

Typical Operating Circuit appears at end of data sheet.

Features

- ◆ ±70V Fault Protection
- ◆ +3.0V to +5.5V Supply Voltage
- ◆ Overvoltage Current Limiting
- ◆ Current Protection at Transmitter Outputs
- ◆ AutoShutdown
- ◆ 250kbps (Max) Data Rate
- ◆ Low Current Consumption in Shutdown 1μA (typ)
- ◆ Thermal Shutdown Protection
- ◆ ±8kV IEC 61000-4-2 Contact-Discharge Method
- ◆ -40°C to +85°C Operating Temperature Range

Ordering Information

PART	TEMP RANGE	PIN-PACKAGE
MAX13223EEUP+	-40°C to +85°C	20 TSSOP

+Denotes a lead(Pb)-free/RoHS-compliant package.

Typical Operating Circuit

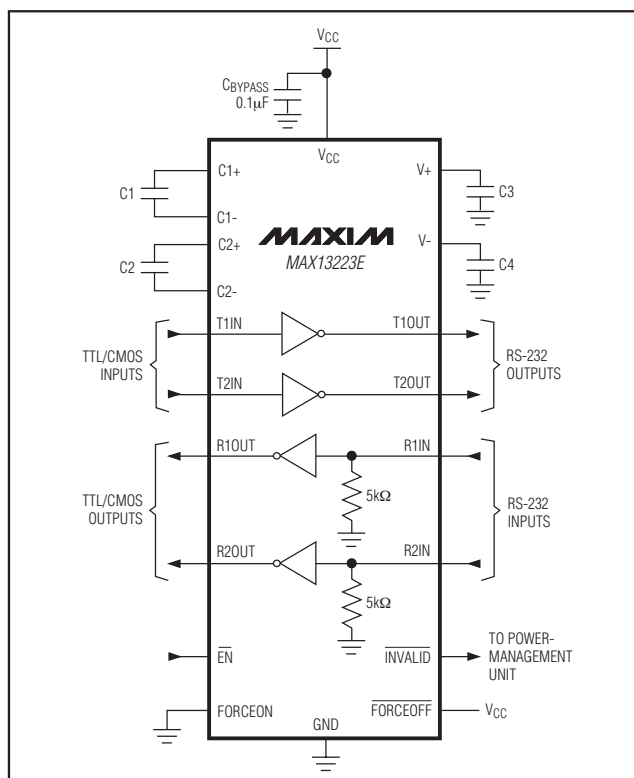

±70V Fault-Protected, 3.0V to 5.5V, 2Tx/2Rx RS-232 Transceiver

ABSOLUTE MAXIMUM RATINGS

(Voltages referenced to GND.)

V _{CC}	-0.3V to +7.0V
V ₊	-0.3V to +7.0V
V ₋	+0.3V to -7.0V
V ₊ to V ₋	+13V
Input Voltages	
T1IN, T2IN, $\overline{\text{EN}}$, FORCEON, $\overline{\text{FORCEOFF}}$	-0.3V to +6.0V
R1IN, R2IN	±70V
Output Voltages	
T1OUT, T2OUT	±70V
R1OUT, R2OUT, $\overline{\text{INVALID}}$	-0.3V to (V _{CC} + 0.3V)
Short-Circuit Duration	
T1OUT, T2OUT	Continuous

Continuous Power Dissipation (T_A = +70°C)

20-Pin TSSOP (derate 13.6mW/°C above +70°C)1084mW

Junction-to-Case Thermal Resistance (θ_{JC}) (Note 1)

20-Pin TSSOP20°C/W

Junction-to-Ambient Thermal Resistance (θ_{JA}) (Note 1)

20-Pin TSSOP73.8°C/W

Operating Temperature Range -40°C to +85°C

Junction Temperature +150°C

Storage Temperature Range -65°C to +150°C

Lead Temperature (soldering, 10s)+300°C

Note 1: Package thermal resistances were obtained using the method described in JEDEC specification JESD51-7, using a four-layer board. For detailed information on package thermal considerations, refer to www.maxim-ic.com/thermal-tutorial.

Stresses beyond those listed under "Absolute Maximum Ratings" may cause permanent damage to the device. These are stress ratings only, and functional operation of the device at these or any other conditions beyond those indicated in the operational sections of the specifications is not implied. Exposure to absolute maximum rating conditions for extended periods may affect device reliability.

ELECTRICAL CHARACTERISTICS

(V_{CC} = +3.0V to +5.5V, T_A = -40°C to +85°C, unless otherwise noted. Typical values are at V_{CC} = +3.3V, T_A = +25°C, unless otherwise noted. For V_{CC} = +3.0V to +3.6V, C1–C3 = 0.1μF, C4 = 1μF. For V_{CC} = +4.5V to +5.5V, C1 = 47nF, C2–C3 = 330nF, C4 = 1μF.) (Note 2)

PARAMETER	SYMBOL	CONDITIONS	MIN	TYP	MAX	UNITS
Supply Voltage	V _{CC}		3.0		5.5	V
Supply Current		AutoShutdown disabled (FORCEON = $\overline{\text{FORCEOFF}}$ = V _{CC}), no load		8	15	mA
Supply Current AutoShutdown	I _{ASD}	FORCEON = GND, $\overline{\text{FORCEOFF}}$ = V _{CC} , R1IN and R2IN idle, T1IN and T2IN idle		1.0	10	μA
Supply Current Shutdown	I _{SD}	$\overline{\text{FORCEOFF}}$ = GND		1.0	10	μA
LOGIC INPUTS						
Input-Logic Low	V _{T,IN,LO}	T _{1IN} , $\overline{\text{EN}}$, FORCEON, $\overline{\text{FORCEOFF}}$, V _{CC} = +3.3V to +3.6V, +5.0V to +5.5V			0.8	V
Input-Logic High	V _{T,IN,HI}	T _{1IN} , FORCEON, $\overline{\text{FORCEOFF}}$, $\overline{\text{EN}}$	V _{CC} = +3.3V	2.0		V
			V _{CC} = +5.0V	2.4		
Transmitter Input Hysteresis	V _{TX,INHYS}			0.5		V
Input Leakage Current	I _{IN,LKG}	T _{1IN} , $\overline{\text{EN}}$, FORCEON, $\overline{\text{FORCEOFF}}$		±0.01	±1	μA
RECEIVER OUTPUTS						
Output Leakage Current	I _{RX,OUT,LKG}	$\overline{\text{EN}}$ = V _{CC}		±0.05	±10	μA
Output-Voltage Low	V _{RX,OUT,LO}	I _{OUT} = 1.6mA			0.4	V
Output-Voltage High	V _{RX,OUT,HI}	I _{OUT} = -1.0mA	V _{CC} - 0.6	V _{CC} - 0.2		V
INVALID OUTPUT (AutoShutdown (FORCEON = GND, FORCEOFF = V_{CC}))						
Receiver-Input Level to $\overline{\text{INVALID}}$ Output High	V _{RX_IN, INV_HI}	Figure 6a	Positive level	2.7		V
			Negative level			

±70V Fault-Protected, 3.0V to 5.5V, 2Tx/2Rx RS-232 Transceiver

MAX13223E

ELECTRICAL CHARACTERISTICS (continued)

(V_{CC} = +3.0V to +5.5V, T_A = -40°C to +85°C, unless otherwise noted. Typical values are at V_{CC} = +3.3V, T_A = +25°C, unless otherwise noted. For V_{CC} = +3.0V to +3.6V, C1–C3 = 0.1μF, C4 = 1μF. For V_{CC} = +4.5V to +5.5V, C1 = 47nF, C2–C3 = 330nF, C4 = 1μF.) (Note 2)

PARAMETER	SYMBOL	CONDITIONS	MIN	TYP	MAX	UNITS
Receiver-Input Level to $\overline{\text{INVALID}}$ Output Low	V _{RX,IN} , INV_LO	Figure 6a	-0.3		+0.3	V
$\overline{\text{INVALID}}$ Output-Voltage Low	V _{RX,INV_LO}	I _{OUT} = 1.6mA			0.4	V
$\overline{\text{INVALID}}$ Output-Voltage High	V _{RX,INV_HI}	I _{OUT} = -1.0mA	V _{CC} - 0.6			V
RECEIVER INPUTS						
Input-Voltage Range	V _{RX,IN}	(Note 3)	-70		+70	V
Overvoltage Threshold	I _{RX,OVTHR}		24	28.3	32	V
Input Threshold Low	V _{RX,LO}	V _{CC} = +3.3V			0.6	V
		V _{CC} = +5.0V			0.8	
Input Threshold High	V _{RX,HI}	V _{CC} = +3.3V	2.4			V
		V _{CC} = +5.0V	2.4			
Input Resistance	R _{RX,INRES}	-24V < V _{R,IN} < +24V (Note 3)	3	5	7	kΩ
		V _{CC} = V ₊ = V ₋ = 0	35		250	
		+32V < V _{R,IN} < +70V	35		250	
TRANSMITTER OUTPUTS						
Output-Voltage Swing	V _O	R _L = 3kΩ, Figure 4	±5	±6		V
Output Resistance	R _{TX,ROUT}	V _{CC} = V ₊ = V ₋ = 0, T _{OUT} = ±2V	300			Ω
Overvoltage Protection Threshold	I _{TX,FB}		14		19	V
Output Short-Circuit Current	I _{TX,SHORT}	T _{OUT} = 0			±80	mA
Overvoltage Current	I _{TX,IFBOUT}	V _{OUT} > V _{TX,FB}			6	mA
		V _{OUT} < -V _{TX,FB}	-6			
Output Leakage Current in Shutdown Mode	I _{TX,LKG}	T _{OUT} = +12V		450	900	μA
		T _{OUT} = -12V, V _{CC} = 0 or 3V to 5.5V in shutdown mode	-150	-80		
PROTECTION						
Overvoltage Protection Range		R1IN, R2IN, T1OUT, T2OUT	-70		+70	V
ESD PROTECTION (Note 4)						
R1IN, R2IN, T1OUT, T2OUT		IEC 6100-4-2 Contact Discharge		±8		kV
		Human Body Model		±8		
All Other Pins		Human Body Model		±2		

±70V Fault-Protected, 3.0V to 5.5V, 2Tx/2Rx RS-232 Transceiver

TIMING CHARACTERISTICS

($V_{CC} = +3.0V$ to $+5.5V$, $T_A = -40^{\circ}C$ to $+85^{\circ}C$, unless otherwise noted. Typical values are at $V_{CC} = +3.3V$, $T_A = +25^{\circ}C$, unless otherwise noted. For $V_{CC} = +3.0V$ to $+3.6V$, $C1-C3 = 0.1\mu F$, $C4 = 1\mu F$. For $V_{CC} = +4.5V$ to $+5.5V$, $C1 = 47nF$, $C2-C3 = 330nF$, $C4 = 1\mu F$.) (Note 2)

PARAMETER	SYMBOL	CONDITIONS	MIN	TYP	MAX	UNITS
Maximum Data Rate	DR	$R_L = 3k\Omega$, $C_L = 1000pF$, one transmitter switching, Figure 1	250			kbps
Receiver Positive or Negative Threshold to INVALID High	t_{INVH}	$V_{CC} = 5V$, Figure 6b		1		μs
Receiver Positive or Negative Threshold to INVALID Low	t_{INVL}	$V_{CC} = 5V$, Figure 6b		30		μs
Receiver Edge to Transmitters Enabled	t_{WU}	$V_{CC} = 5V$, Figure 6b		135		μs
Receiver-Output Enable Time	$t_{RX,EN}$	Normal operation		200		ns
Receiver-Output Disable Time	$t_{RX,DIS}$	Normal operation		200		ns
Receiver Skew	$ t_{PRHL} - t_{PRLH} $			50		ns
Transmitter Skew	$ t_{PTHL} - t_{PTLH} $	(Note 5)		200		ns
Receiver Propagation Delay	t_{PRHL}	$C_L = 150pF$, Figure 4		0.3		μs
	t_{PRLH}			0.3		
Transmitter Propagation Delay	t_{PTHL}	$C_L = 1nF$, $R_L = 3k\Omega$, Figure 3		0.8		μs
	t_{PTLH}			0.6		
Transmitter Fall Time or Rise Time	t_R, t_F	Figure 3		0.3		μs
Transmitter Time to Exit Shutdown	t_{SHDN}	Figure 7		100		μs
Output Recovery Time	$t_{TX,REC}$	$C_L = 1nF$, $R_L = 5k\Omega$ (Note 6)		100		μs
Transition-Region Slew Rate	SR_{OUT}	$V_{CC} = 3.3V$, $R_L = 3k\Omega$ to $7k\Omega$, $T_A = +25^{\circ}C$, measured from $+3V$ to $-3V$ or $-3V$ to $+3V$, one transmitter switching, $C_L = 1nF$	6		30	$V/\mu s$

Note 2: All devices are 100% production tested at $T_A = +85^{\circ}C$. Specifications are over $-40^{\circ}C$ to $+85^{\circ}C$ and are guaranteed by design.

Note 3: Both receivers will operate over the $\pm 70V$ input range. The input resistance increases with input voltage. The input resistance will increase within $24V \leq IVR_{INI} \leq 32V$.

Note 4: Guaranteed by design, not production tested.

Note 5: Transmitter skew is measured at the transmitter zero crosspoints.

Note 6: Output recovery time is the delayed time for the transmitter to enter normal operating mode after an overvoltage condition.

±70V Fault-Protected, 3.0V to 5.5V, 2Tx/2Rx RS-232 Transceiver

MAX13223E

Test Circuits

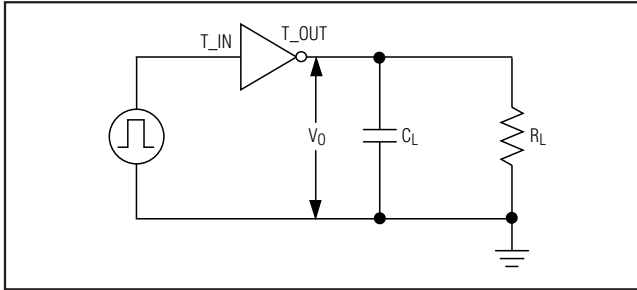

Figure 1. Driver Test Circuit

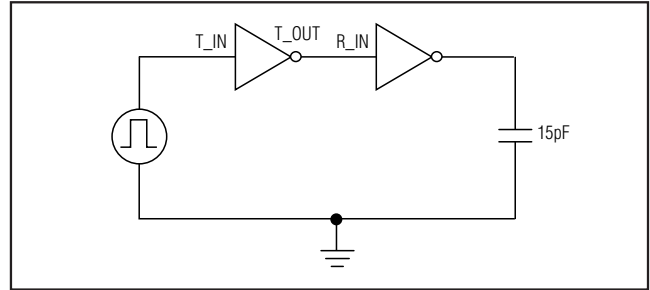

Figure 2. Receiver Test Circuit

Timing Diagrams

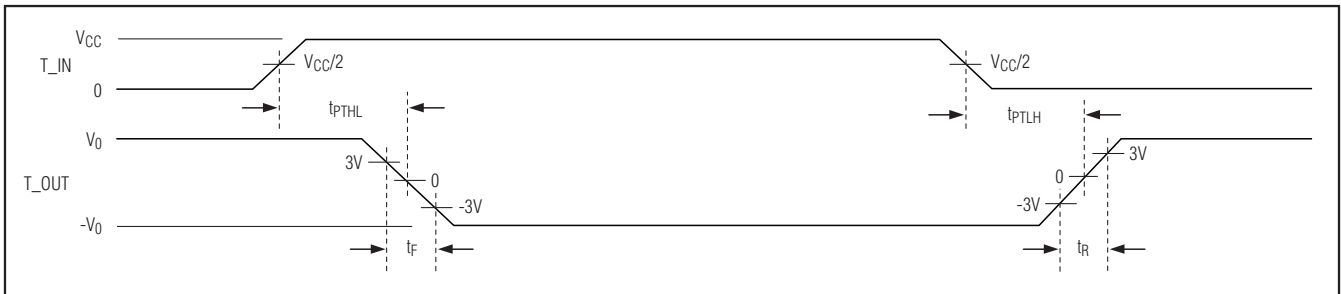

Figure 3. Driver Propagation Delay

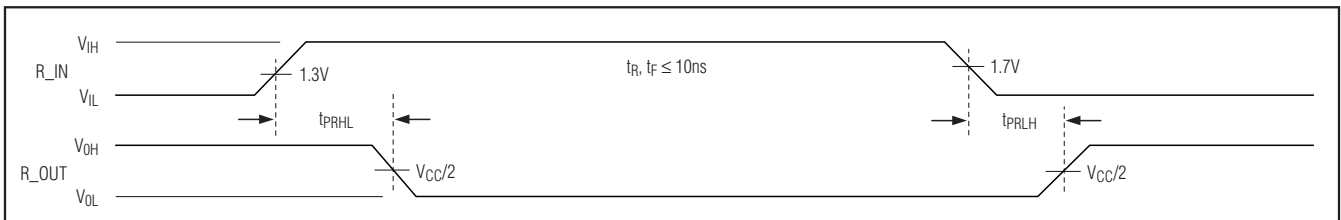
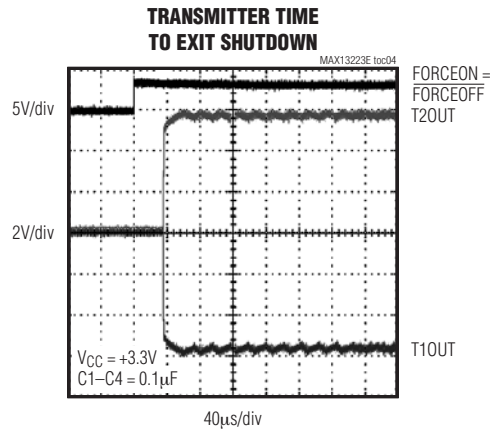
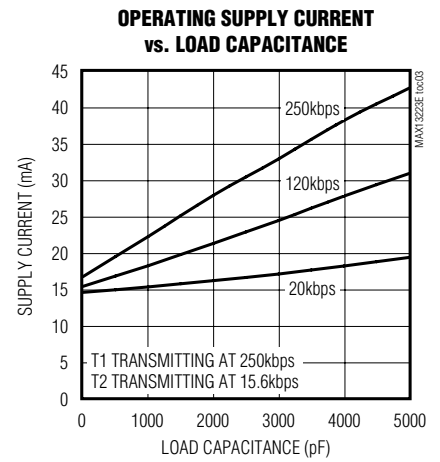
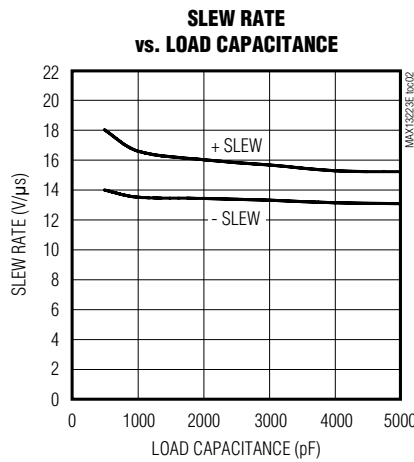
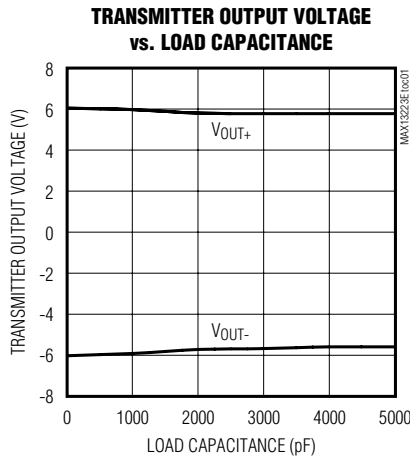

Figure 4. Receiver Propagation Delay

±70V Fault-Protected, 3.0V to 5.5V, 2Tx/2Rx RS-232 Transceiver

Typical Operating Characteristics

(T_A = +25°C, unless otherwise noted.)



±70V Fault-Protected, 3.0V to 5.5V, 2Tx/2Rx RS-232 Transceiver

MAX13223E

Pin Description

PIN	NAME	FUNCTION
1	$\overline{\text{EN}}$	Receiver Enable Control Input. Drive $\overline{\text{EN}}$ low for normal operation. Drive $\overline{\text{EN}}$ high to force the receiver outputs (R1OUT, R2OUT) into a high-impedance state.
2	C1+	Positive Terminal of the Voltage Doubler Charge-Pump Capacitor
3	V+	+5.5V Generated by Charge Pump
4	C1-	Negative Terminal of the Voltage Doubler Charge-Pump Capacitor
5	C2+	Positive Terminal of Inverting Charge-Pump Capacitor
6	C2-	Negative Terminal of Inverting Charge-Pump Capacitor
7	V-	-5.5V Generated by Charge Pump
8	T2OUT	RS-232 Transmitter 2 Output
9	R2IN	RS-232 Receiver 2 Input
10	R2OUT	Receiver 2 Logic Output
11	$\overline{\text{INVALID}}$	Valid Signal Detector Output. $\overline{\text{INVALID}}$ is high if a valid RS-232 level is present on any receiver input.
12	T2IN	Transmitter 2 Logic Input
13	T1IN	Transmitter 1 Logic Input
14	FORCEON	Active-High FORCEON Input. Drive FORCEON high to override AutoShutdown, keeping transmitters and charge pump on (FORCEOFF must be high).
15	R1OUT	Receiver 1 Logic Output
16	R1IN	RS-232 Receiver 1 Input
17	T1OUT	RS-232 Transmitter 1 Output
18	GND	Ground
19	VCC	+3.0V to +5.5V Supply Voltage. Bypass VCC with a 0.1μF ceramic capacitor located as close to the device as possible.
20	$\overline{\text{FORCEOFF}}$	Active-Low $\overline{\text{FORCEOFF}}$ Input. Drive $\overline{\text{FORCEOFF}}$ low to shut down transmitters, receivers, and on-board charge pumps, overriding AutoShutdown and FORCEON.

Detailed Description

Figure 2 shows the receiver test circuit. Figure 3 shows driver propagation delay and Figure 4 shows receiver propagation delay.

Dual Charge-Pump Voltage Converter

The MAX13223E internal power supply consists of a dual-mode regulated charge pump that provides output voltages of +5.5V (doubling charge pump) and -5.5V (inverting charge pump), regardless of the input voltage (VCC) over the +3.0V to +5.5V range. The charge pumps operate in a discontinuous mode. If the output voltages are less than 5.5V, the charge pumps are enabled. If the output voltages exceed 5.5V, the charge pumps are disabled. Each charge pump requires a flying capacitor (C1, C2) and a reservoir capacitor (C3, C4) to generate the V+ and V- supplies.

RS-232 Transmitters

The transmitters are inverting level translators that convert logic levels to EIA/TIA-232/V.28 levels. They guarantee a 250kbps data rate with worst-case loads of 3kΩ in parallel with 1000pF, providing compatibility with PC-to-PC communication software. The MAX13223E can operate at data rates of 250kbps (max). Transmitters can be paralleled to drive multiple receivers. When $\overline{\text{FORCEOFF}}$ is driven to ground, or the AutoShutdown circuitry senses invalid voltage levels at all receiver inputs, the transmitters are disabled and the outputs are forced into a high-impedance state. Figure 5 shows a complete system connection.

RS-232 Receivers

The MAX13223E's receivers convert RS-232 signals to logic output levels. Both receiver outputs can be tristated using the $\overline{\text{EN}}$ input. In shutdown ($\overline{\text{FORCEOFF}}$ = low) or in AutoShutdown, the MAX13223E's receivers are active (Table 1). Driving $\overline{\text{EN}}$ high places the receivers' outputs in a high-impedance state.

±70V Fault-Protected, 3.0V to 5.5V, 2Tx/2Rx RS-232 Transceiver

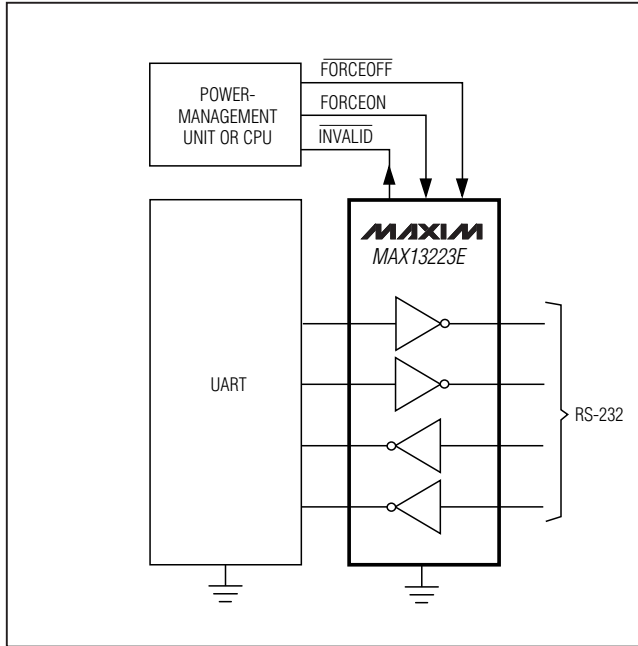

Figure 5. Interface Under Control of PMU

Table 1. Receiver Control Truth Table

$\overline{\text{EN}}$	R_OUT
0	Active
1	High Impedence

AutoShutdown

The MAX13223E achieves 1µA supply current with Maxim's AutoShutdown feature, which operates when FORCEON is low and FORCEOFF is high. When the device senses no valid signal levels on both receiver inputs for > 30µs (typ), the onboard charge pump and drivers are shut off, reducing supply current to 1µA. This occurs if the RS-232 cable is disconnected or the connected peripheral transmitters are turned off. The device turns on again when a valid level is applied to either RS-232 receiver input. As a result, the system saves power. Table 2 summarizes the MAX13223E's operating modes. FORCEON and FORCEOFF override

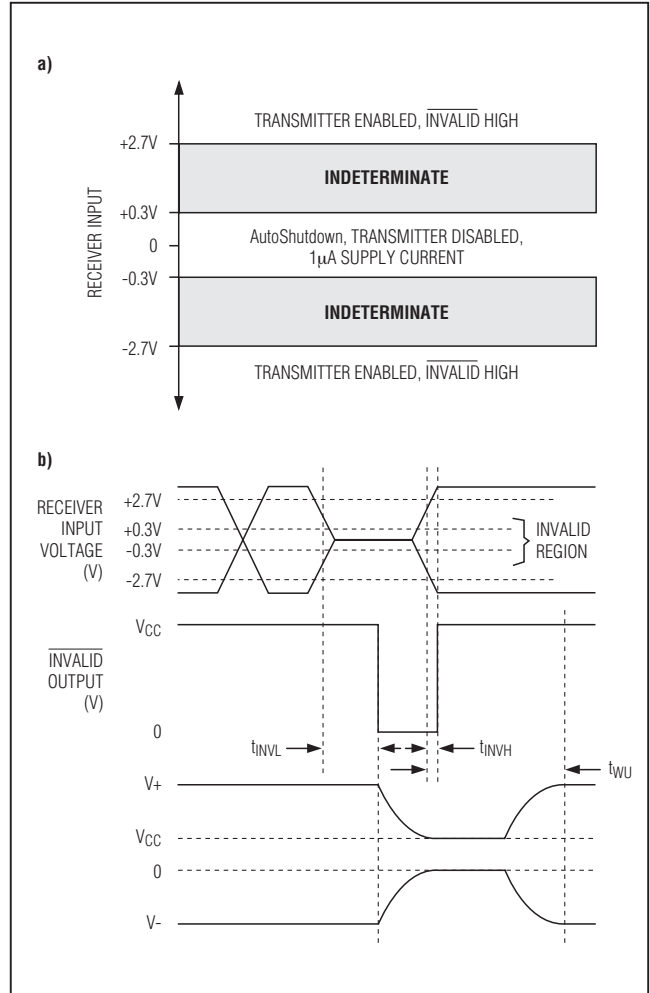

Figures 6a and 6b. Trip Levels for Entering and Exiting AutoShutdown

AutoShutdown. When neither control is asserted, the IC selects between these states automatically, based on receiver input levels. Figure 6a shows the input levels and Figure 6b shows the timing diagram for AutoShutdown operation.

Software-Controlled Shutdown

If direct software control is desired, INVALID can be used to indicate a DTR or Ring indicator signal. Connect FORCEOFF and FORCEON together to bypass AutoShutdown; therefore, the line acts as a SHDN input.

±70V Fault-Protected, 3.0V to 5.5V, 2Tx/2Rx RS-232 Transceiver

MAX13223E

Table 2. AutoShutdown Control

INPUTS			OUTPUTS		
FORCEOFF	FORCEON	VALID RECEIVER INPUT LEVEL	INVALID OUTPUT	OPERATION MODE	T_OUT
0	X	No	0	Shutdown (Forced Off)	High-Z
0	X	Yes	1	Shutdown (Forced Off)	High-Z
1	0	No	0	Shutdown (AutoShutdown)	High-Z
1	0	Yes	1	Active (AutoShutdown)	Active
1	1	No	0	Active (Forced On)	Active
1	1	Yes	1	Active (Forced On)	Active

X = Don't Care.

Applications Information

Capacitor Selection

The capacitor type used for C1–C4 is not critical for proper operation; either polarized or nonpolarized capacitors may be used. The charge pump requires 0.1µF capacitors for 3.3V operation. For other supply voltages, see Table 3 for required capacitor values. Do not use values smaller than those listed in Table 3. Increasing the capacitor values (e.g., by a factor of 2) reduces ripple on the transmitter outputs and slightly reduces power consumption. C2, C3, and C4 can be increased without changing C1's value. **However, do not increase C1 without also increasing the values of C2, C3, and C4 to maintain the proper ratios (C1 to the other capacitors).** When using the minimum required capacitor values, make sure the capacitor value does not degrade excessively with temperature. If in doubt, use capacitors with a larger nominal value. The capacitor's equivalent series resistance (ESR) usually rises at low temperatures and influences the amount of ripple on V+ and V-.

Table 3. Required Capacitor Values

V _{CC} (V)	C1, C _{BYPASS} (µF)	C2, C3 (µF)	C4 (µF)
3.0 to 3.6	0.1	0.1	1
4.5 to 5.5	0.047	0.33	1

Power-Supply Decoupling

In most circumstances, a 0.1µF V_{CC} bypass capacitor is adequate. In applications that are sensitive to power-supply noise, decouple V_{CC} to ground with a capacitor of the same value as the charge-pump capacitor C1. Connect bypass capacitors as close to the IC as possible.

Transmitter Outputs when Exiting Shutdown

Figure 7 shows two transmitter outputs when exiting shutdown mode. As they become active, the two transmitter outputs are shown going to opposite RS-232 levels. Each transmitter is loaded with 3kΩ in parallel with 2500pF. The transmitter outputs display no ringing or undesirable transients as they come out of shutdown. Note that the transmitters are enabled only when the magnitude of V- exceeds approximately 3V.

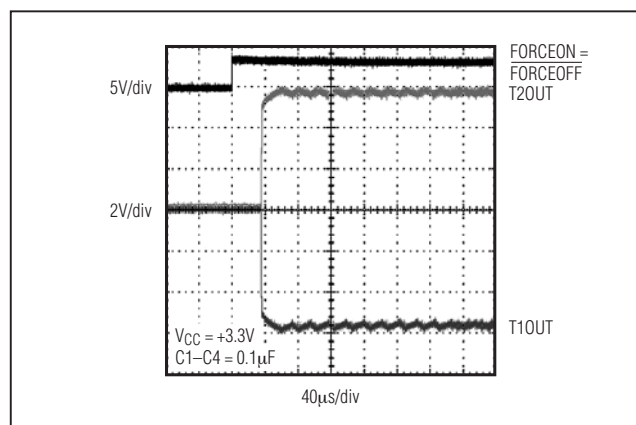

Figure 7. Transmitter Outputs when Exiting Shutdown or Powering Up

±70V Fault-Protected, 3.0V to 5.5V, 2Tx/2Rx RS-232 Transceiver

Fault Protection

The MAX13223E is designed to survive faults such as direct shorts to power supplies, miswiring faults, connector failures, and tool misapplications of the transmitter outputs and receiver inputs to voltages in the ±70V range without damage. This fault protection is applicable in all modes of the MAX13223E: active, shutdown, and powered down. Both receivers operate over the ±70V input range, but the termination resistor ($R_{RX,I}$) increases when $|V_{R_IN}|$ voltage exceeds ±32V. A receiver's input termination resistor reduces to its nominal value if the input voltage reduces to within the ±24V range. The receiver inputs and transmitter outputs are independently fault protected.

±8kV ESD Protection

As with all Maxim devices, ESD-protection structures are incorporated on all pins to protect against electrostatic discharges encountered during handling and assembly. In using the MAX13223E, C4 must be a 1μF capacitor for the extended ESD protection. The driver outputs and receiver inputs of the MAX13223E have extra protection against static electricity. Maxim's engineers have developed state-of-the-art structures to protect these pins against ESD of ±8kV without damage. The ESD structures withstand high ESD in all states: normal operation, shutdown, and powered down. After an ESD event, Maxim's E versions keep working without latchup, whereas competing RS-232 products can latch and must be powered down to remove latchup. ESD protection can be tested in various ways. The transmitter outputs and receiver inputs of this product family are characterized for protection to the following limits:

- 1) ±8kV using the Human Body Model
- 2) ±8kV using the Contact-Discharge Method specified in IEC 61000-4-2

ESD Test Conditions

ESD performance depends on a variety of conditions. Contact Maxim for a reliability report that documents test setup, test methodology, and test results.

Human Body Model

Figure 8a shows the Human Body Model and Figure 8b shows the current waveform it generates when discharged into a low impedance. This model consists of a 100pF capacitor charged to the ESD voltage of interest, which is then discharged into the test device through a 1.5kΩ resistor.

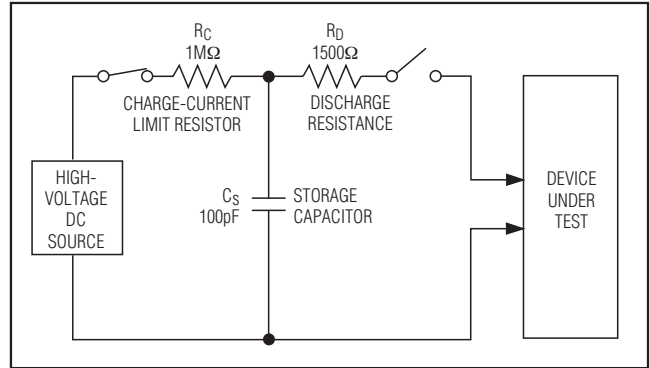

Figure 8a. Human Body ESD Test Model

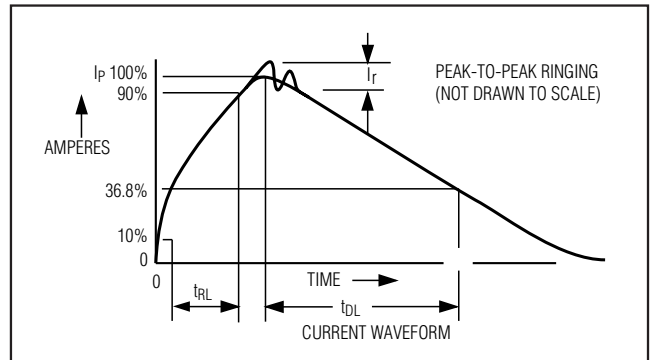

Figure 8b. Human Body Current Waveform

IEC 61000-4-2

The IEC 61000-4-2 standard covers ESD testing and performance of finished equipment. It does not specifically refer to integrated circuits. The major difference between tests done using the Human Body Model and IEC 61000-4-2 is higher peak current in IEC 61000-4-2, because series resistance is lower in the IEC 61000-4-2 model. Hence, the ESD withstand voltage measured to IEC 61000-4-2 is generally lower than that measured using the Human Body Model. Figure 9a shows the IEC 61000-4-2 model and Figure 9b shows the current waveform for the ±8kV, IEC 61000-4-2, level 4, ESD Contact-Discharge Method.

±70V Fault-Protected, 3.0V to 5.5V, 2Tx/2Rx RS-232 Transceiver

MAX13223E

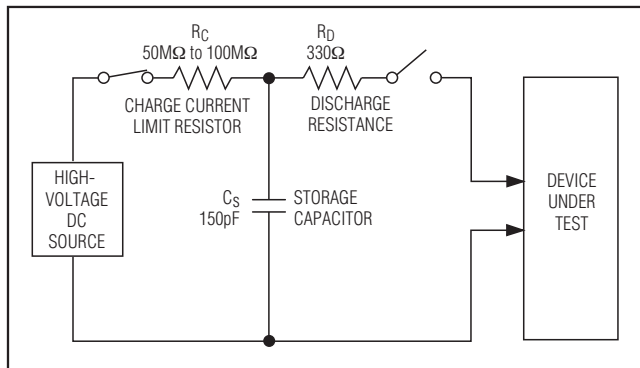

Figure 9a. IEC 61000-4-2 ESD Test Model

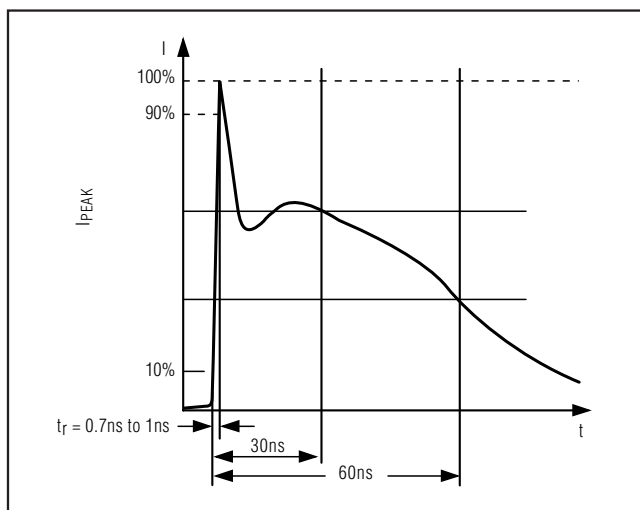
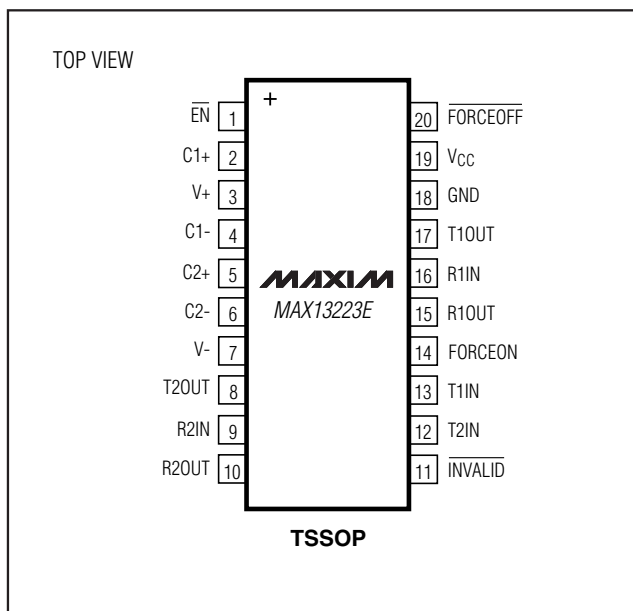

Figure 9b. IEC 61000-4-2 ESD Generator Current Waveform

Pin Configuration



Chip Information

PROCESS: CMOS

Package Information

For the latest package outline information and land patterns, go to www.maxim-ic.com/packages.

PACKAGE TYPE	PACKAGE CODE	DOCUMENT NO.
20 TSSOP	U20+2	21-0066

Maxim cannot assume responsibility for use of any circuitry other than circuitry entirely embodied in a Maxim product. No circuit patent licenses are implied. Maxim reserves the right to change the circuitry and specifications without notice at any time.

Maxim Integrated Products, 120 San Gabriel Drive, Sunnyvale, CA 94086 408-737-7600 11