



# ±15kV ESD-Protected, 10Mbps, 3V/5V, Quad RS-422/RS-485 Receivers

MAX3095/MAX3096

## General Description

The MAX3095/MAX3096 are rugged, low-power, quad, RS-422/RS-485 receivers with electrostatic discharge (ESD) protection for use in harsh environments. All receiver inputs are protected to ±15kV using IEC 1000-4-2 Air-Gap Discharge, ±8kV using IEC 1000-4-2 Contact Discharge, and ±15kV using the Human Body Model. The MAX3095 operates from a +5V supply, while the MAX3096 operates from a +3.3V supply. Receiver propagation delays are guaranteed to within ±8ns of a pre-determined value, thereby ensuring device-to-device matching across production lots.

Complementary enable inputs can be used to place the devices in a 1nA low-power shutdown mode in which the receiver outputs are high impedance. When active, these receivers have a fail-safe feature that guarantees a logic-high output if the input is open circuit. They also feature a quarter-unit-load input impedance that allows 128 receivers on a bus.

The MAX3095/MAX3096 are pin-compatible, low-power upgrades to the industry-standard '26LS32. They are available in a space-saving QSOP package.

## Applications

- Telecommunications Equipment
- Rugged RS-422/RS-485/RS-423 Bus Receiver
- Receivers for ESD-Sensitive Applications
- Level Translators

## Functional Diagram

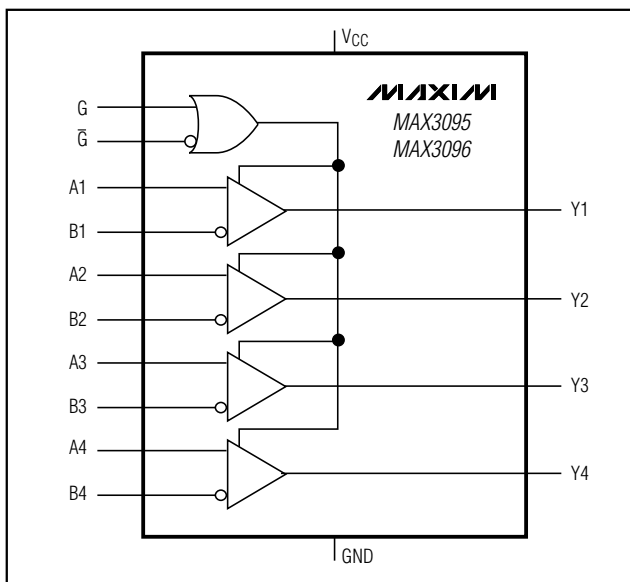

## Features

- ◆ ESD Protection:
  - ±15kV—IEC 1000-4-2, Air-Gap Discharge
  - ±8kV—IEC 1000-4-2, Contact Discharge
  - ±15kV—Human Body Model
- ◆ Guaranteed Propagation-Delay Tolerance Between All ICs:
  - ±8ns (MAX3095)
  - ±10ns (MAX3096)
- ◆ Single +3V Operation (MAX3096)
- ◆ Single +5V Operation (MAX3095)
- ◆ 16-Pin QSOP (8-pin SO footprint)
- ◆ 10Mbps Data Rate
- ◆ Allow up to 128 Receivers on the Bus
- ◆ 1nA Low-Power Shutdown Mode
- ◆ 2.4mA Operating Supply Current
- ◆ Pin-Compatible Upgrades to '26LS32

## Ordering Information

PART	TEMP. RANGE	PIN-PACKAGE
MAX3095CPE	0°C to +70°C	16 Plastic DIP
MAX3095CSE	0°C to +70°C	16 Narrow SO
MAX3095CEE	0°C to +70°C	16 QSOP
MAX3095EPE	-40°C to +85°C	16 Plastic DIP
MAX3095ESE	-40°C to +85°C	16 Narrow SO
MAX3095EEE	-40°C to +85°C	16 QSOP
MAX3096CPE	0°C to +70°C	16 Plastic DIP
MAX3096CSE	0°C to +70°C	16 Narrow SO
MAX3096CEE	0°C to +70°C	16 QSOP
MAX3096EPE	-40°C to +85°C	16 Plastic DIP
MAX3096ESE	-40°C to +85°C	16 Narrow SO
MAX3096EEE	-40°C to +85°C	16 QSOP

## Pin Configuration

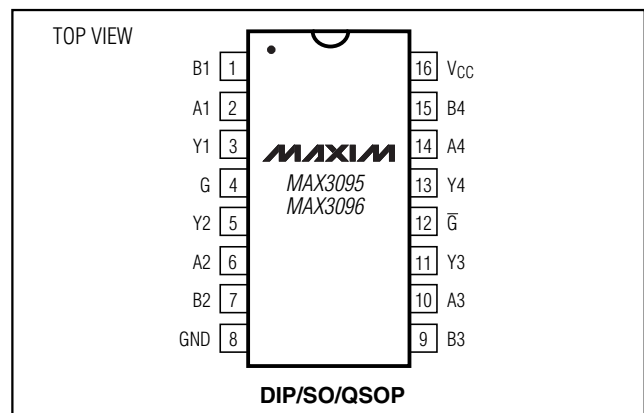

# ±15kV ESD-Protected, 10Mbps, 3V/5V, Quad RS-422/RS-485 Receivers

## ABSOLUTE MAXIMUM RATINGS

Supply Voltage ( $V_{CC}$ ).....7V	Operating Temperature Ranges
Control Input Voltage ( $G, \bar{G}$ ).....-0.3V to ( $V_{CC} + 0.3V$ )	MAX309_C_ _ .....0°C to +70°C
Receiver Input Voltage ( $A_-, B_-$ ).....±25V	MAX309_E_ _ .....-40°C to +85°C
Receiver Output Voltage ( $Y_-$ ).....-0.3V to ( $V_{CC} + 0.3V$ )	Storage Temperature Range .....-65°C to +160°C
Continuous Power Dissipation ( $T_A = +70^\circ\text{C}$ )	Lead Temperature (soldering, 10s) .....+300°C
16-Pin Plastic DIP (derate 10.5mW/°C above +70°C) .762mW	
16-Pin SO (derate 8.7mW/°C above +70°C).....696mW	
16-Pin QSOP (derate 8.3mW/°C above +70°C).....667mW	

Stresses beyond those listed under "Absolute Maximum Ratings" may cause permanent damage to the device. These are stress ratings only, and functional operation of the device at these or any other conditions beyond those indicated in the operational sections of the specifications is not implied. Exposure to absolute maximum rating conditions for extended periods may affect device reliability.

## DC ELECTRICAL CHARACTERISTICS—MAX3095

( $V_{CC} = 5V \pm 5\%$ ,  $T_A = T_{MIN}$  to  $T_{MAX}$ , unless otherwise noted. Typical values are at  $T_A = +25^\circ\text{C}$ .) (Note 1)

PARAMETER	SYMBOL	CONDITIONS	MIN	TYP	MAX	UNITS
Receiver Differential Input Threshold	$V_{TH}$	$-7V \leq V_{CM} \leq 12V$	-200		200	mV
Receiver Input Hysteresis		$V_{CM} = 0$		45		mV
Receiver Input Current ( $A_-, B_-$ )	$I_{IN}$	$V_{CC} = 0$ or $5.25V$			250	$\mu\text{A}$
					-200	
Enable Input Current ( $G, \bar{G}$ )					±1	$\mu\text{A}$
Enable Input High Voltage ( $G, \bar{G}$ )	$V_{IH}$		2.0			V
Enable Input Low Voltage ( $G, \bar{G}$ )	$V_{IL}$				0.8	V
Receiver Output High Voltage	$V_{OH}$	$I_{OUT} = -4\text{mA}$ , $V_{ID} = 200\text{mV}$ , $G = V_{CC}$ or $\bar{G} = \text{GND}$ , Figure 1	$V_{CC} - 1.5$			V
Receiver Output Low Voltage	$V_{OL}$	$I_{OUT} = 4\text{mA}$ , $V_{ID} = -200\text{mV}$ , $G = V_{CC}$ or $\bar{G} = \text{GND}$ , Figure 1			0.4	V
Three-State Current at Receiver Output	$I_{OZR}$	$0 \leq V_{OUT} \leq V_{CC}$ , $G = \text{GND}$ and $\bar{G} = V_{CC}$			±1	$\mu\text{A}$
Output Short-Circuit Current	$I_{OSR}$	$0 \leq V_{OUT} \leq V_{CC}$ , $G = V_{CC}$ or $\bar{G} = \text{GND}$	±7		±75	mA
Receiver Input Resistance	$R_{IN}$	$-7V \leq V_{CM} \leq 12V$	48			$k\Omega$
Supply Current	$I_{CC}$	No load, $G = V_{CC}$ or $\bar{G} = \text{GND}$		2.4	3.5	mA
		$G = \text{GND}$ and $\bar{G} = V_{CC}$		0.001	10	$\mu\text{A}$
ESD Protection (Note 2)		Human Body Model		±15		kV
		IEC1000-4-2 (Air-Gap Discharge)		±15		
		IEC1000-4-2 (Contact Discharge)		±8		

# **±15kV ESD-Protected, 10Mbps, 3V/5V, Quad RS-422/RS-485 Receivers**

**MAX3095/MAX3096**

## **SWITCHING CHARACTERISTICS—MAX3095**

( $V_{CC} = 5V \pm 5\%$ ,  $T_A = T_{MIN}$  to  $T_{MAX}$ , unless otherwise noted. Typical values are at  $T_A = +25^\circ C$ .)

PARAMETER	SYMBOL	CONDITIONS	MIN	TYP	MAX	UNITS		
Input-to-Output Propagation Delay	$t_{PLH}$ , $t_{PHL}$	$V_{CC} = 5V \pm 5\%$ , $T_A = T_{MIN}$ to $T_{MAX}$	65		98	ns		
		$ V_{ID}  = 3V$ , Figure 2	$V_{CC} = 5.25V$	$T_A = +85^\circ C$	78		86	94
				$T_A = +25^\circ C$	71		79	87
				$T_A = -40^\circ C$	65		73	81
		$V_{CC} = 4.75V$	$T_A = +85^\circ C$	82	90		98	
			$T_A = +25^\circ C$	74	82		90	
			$T_A = -40^\circ C$	68	76		84	
Device-to-Device Propagation-Delay Matching		$ V_{ID}  = 3V$ , Figure 2, matched conditions			16	ns		
Propagation-Delay Skew ( $t_{PLH} - t_{PHL}$ )	$t_{SK}$			-4	$\pm 10$	ns		
Output Enable Time to Low Level	$t_{ZL}$	Figure 3		600	800	ns		
Output Enable Time to High Level	$t_{ZH}$	Figure 3		600	800	ns		
Output Disable Time from Low Level	$t_{LZ}$	Figure 3		60	100	ns		
Output Disable Time from High Level	$t_{HZ}$	Figure 3		60	100	ns		
Maximum Data Rate	$f_{MAX}$		10			Mbps		

## **DC ELECTRICAL CHARACTERISTICS—MAX3096**

( $V_{CC} = 3.0V$  to  $3.6V$ ,  $T_A = T_{MIN}$  to  $T_{MAX}$ , unless otherwise noted. Typical values are at  $V_{CC} = 3.3V$ ,  $T_A = +25^\circ C$ .) (Note 1)

PARAMETER	SYMBOL	CONDITIONS	MIN	TYP	MAX	UNITS
Receiver Differential Input Threshold	$V_{TH}$	$-7V \leq V_{CM} \leq 12V$	-200		200	mV
Receiver Input Hysteresis		$V_{CM} = 0$		45		mV
Receiver Input Current ( $A_{-}$ , $B_{-}$ )	$I_{IN}$	$V_{CC} = 0$ or $3.6V$			250	$\mu A$
					-200	
Enable Input Current ( $G$ , $\overline{G}$ )					$\pm 1$	$\mu A$
Enable Input High Voltage ( $G$ , $\overline{G}$ )	$V_{IH}$		2.0			V
Enable Input Low Voltage ( $G$ , $\overline{G}$ )	$V_{IL}$				0.8	V
Receiver Output High Voltage	$V_{OH}$	$I_{OUT} = -1.5mA$ , $V_{ID} = 200mV$ , $G = V_{CC}$ or $\overline{G} = GND$ , Figure 1	$V_{CC} - 0.4$			V
Receiver Output Low Voltage	$V_{OL}$	$I_{OUT} = 2.5mA$ , $V_{ID} = -200mV$ , $G = V_{CC}$ or $\overline{G} = GND$ , Figure 1			0.4	V
Three-State Current at Receiver Output	$I_{OZR}$	$0 \leq V_{OUT} \leq V_{CC}$ , $G = GND$ and $\overline{G} = V_{CC}$			$\pm 1$	$\mu A$
Output Short-Circuit Current	$I_{OSR}$	$0 \leq V_{OUT} \leq V_{CC}$ , $G = V_{CC}$ or $\overline{G} = GND$	$\pm 4$		$\pm 60$	mA
Receiver Input Resistance	$R_{IN}$	$-7V \leq V_{CM} \leq 12V$	48			$k\Omega$

# ±15kV ESD-Protected, 10Mbps, 3V/5V, Quad RS-422/RS-485 Receivers

## DC ELECTRICAL CHARACTERISTICS—MAX3096 (continued)

( $V_{CC} = 3.0V$  to  $3.6V$ ,  $T_A = T_{MIN}$  to  $T_{MAX}$ , unless otherwise noted. Typical values are at  $V_{CC} = 3.3V$ ,  $T_A = +25^\circ C$ .) (Note 1)

PARAMETER	SYMBOL	CONDITIONS	MIN	TYP	MAX	UNITS
Supply Current	$I_{CC}$	No load, $G = V_{CC}$ or $\overline{G} = GND$		2.4	4.0	mA
		$G = GND$ and $\overline{G} = V_{CC}$		0.001	10	$\mu A$
ESD Protection (Note 2)		Human Body Model		±15		kV
		IEC1000-4-2 (Air-Gap Discharge)		±15		
		IEC1000-4-2 (Contact Discharge)		±8		

## SWITCHING CHARACTERISTICS—MAX3096

( $V_{CC} = 3.0V$  to  $3.6V$ ,  $T_A = T_{MIN}$  to  $T_{MAX}$ , unless otherwise noted. Typical values are at  $T_A = +25^\circ C$ .)

PARAMETER	SYMBOL	CONDITIONS	MIN	TYP	MAX	UNITS		
Input-to-Output Propagation Delay	$t_{PLH}$ , $t_{PHL}$	$V_{CC} = 3.0V$ to $3.6V$ , $T_A = T_{MIN}$ to $T_{MAX}$			69	123	ns	
		$ V_{ID}  = 3V$ , Figure 2	$V_{CC} = 3.60V$	$T_A = +85^\circ C$	88	98		108
				$T_A = +25^\circ C$	78	88		98
				$T_A = -40^\circ C$	69	79		89
		$V_{CC} = 3.00V$	$T_A = +85^\circ C$	103	113	123		
			$T_A = +25^\circ C$	91	101	111		
			$T_A = -40^\circ C$	82	92	102		
Device-to-Device Propagation-Delay Matching		$ V_{ID}  = 3V$ , Figure 2, matched conditions			20	ns		
Propagation-Delay Skew ( $t_{PLH} - t_{PHL}$ )	$t_{SK}$			-2	±10	ns		
Output Enable Time to Low Level	$t_{ZL}$	Figure 3		600	1000	ns		
Output Enable Time to High Level	$t_{ZH}$	Figure 3		600	1000	ns		
Output Disable Time from Low Level	$t_{LZ}$	Figure 3		80	180	ns		
Output Disable Time from High Level	$t_{HZ}$	Figure 3		80	180	ns		
Maximum Data Rate	$f_{MAX}$		10			Mbps		

**Note 1:** All currents into the device are positive; all currents out of the device are negative. All voltages are referred to device ground, unless otherwise noted.

**Note 2:** Receiver inputs (A<sub>-</sub>, B<sub>-</sub>).

# ±15kV ESD-Protected, 10Mbps, 3V/5V, Quad RS-422/RS-485 Receivers

## Typical Operating Characteristics

( $V_{CC} = 5V$  for MAX3095,  $V_{CC} = 3.3V$  for MAX3096,  $T_A = +25^\circ C$ , unless otherwise noted.)

**MAX3095/MAX3096**

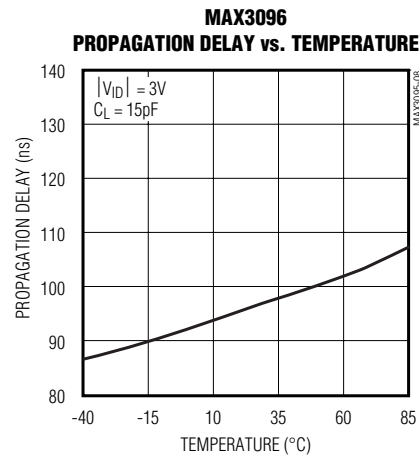
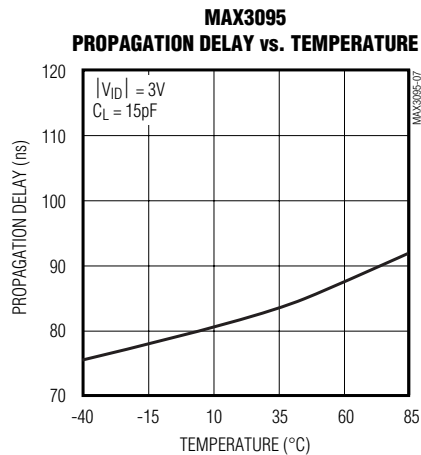
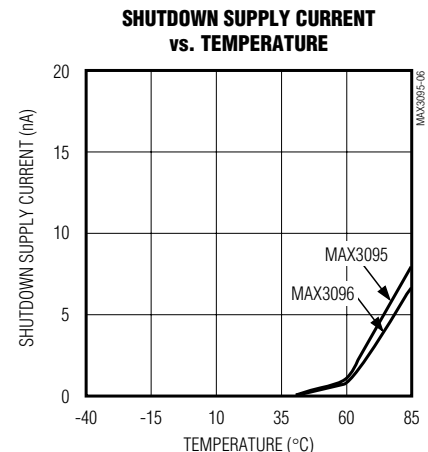
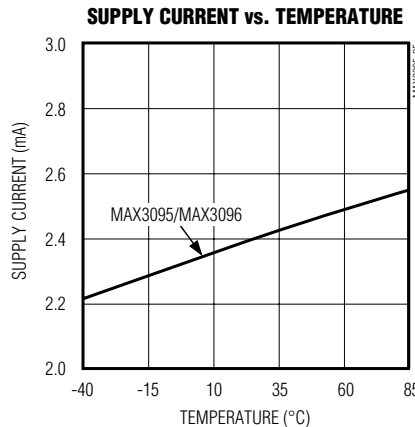
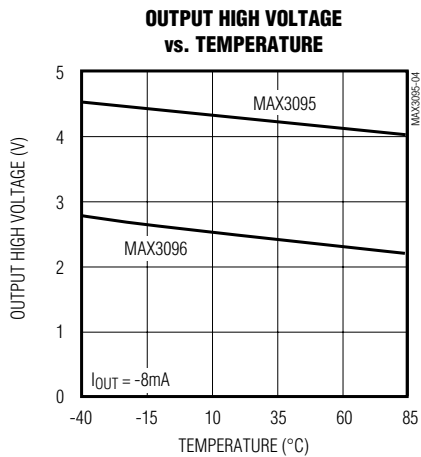
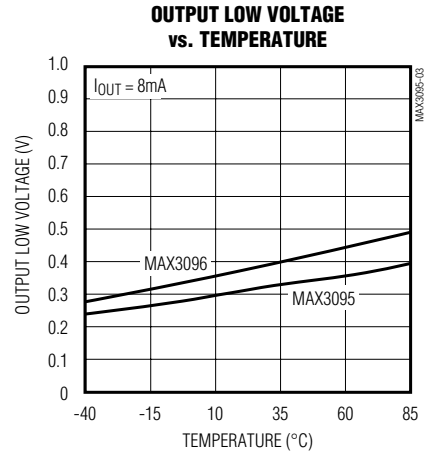
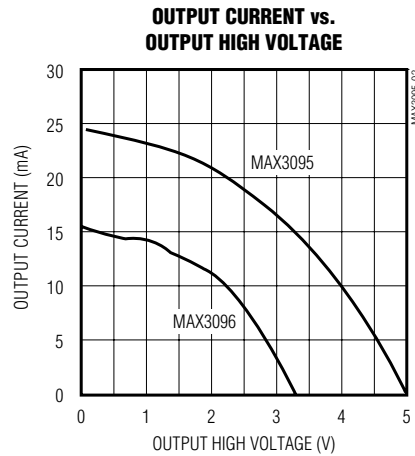
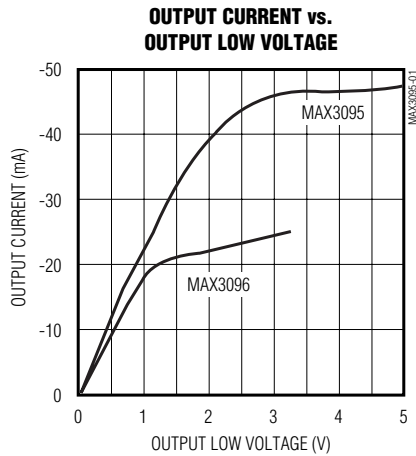

# **$\pm 15\text{kV}$ ESD-Protected, 10Mbps, 3V/5V, Quad RS-422/RS-485 Receivers**

## **Typical Operating Characteristics (continued)**

( $V_{CC} = 5\text{V}$  for MAX3095,  $V_{CC} = 3.3\text{V}$  for MAX3096,  $T_A = +25^\circ\text{C}$ , unless otherwise noted.)

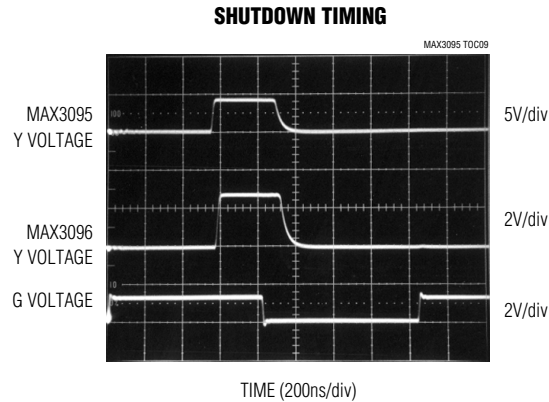

CIRCUIT OF FIGURE 3,  
S1 OPEN, S2 CLOSED, S3 = 1V

## **Pin Description**

PIN	NAME	FUNCTION
1	B1	Inverting Receiver Input
2	A1	Noninverting Receiver Input
3	Y1	Receiver Output. Enabled when $G = \text{high}$ OR $\overline{G} = \text{low}$ . Y1 will be logic high if $A1 > B1$ by 200mV, and low if $A1 < B1$ by 200mV. It will be logic high if A1 and B1 remain floating. Otherwise, the state is undetermined. Y1 goes high impedance when the $G = \text{low}$ and $\overline{G} = \text{high}$ .
4	G	Receiver Output Enable High. A logic high on this input enables all receivers. When taken low and $\overline{G}$ is high, all receivers are shut down, and the outputs go high impedance.
5	Y2	Receiver Output. Same functionality as Y1.
6	A2	Noninverting Receiver Input
7	B2	Inverting Receiver Input
8	GND	Ground
9	B3	Inverting Receiver Input
10	A3	Noninverting Receiver Input
11	Y3	Receiver Output. Same functionality as Y1.
12	$\overline{G}$	Receiver Output Enable Low. A logic low on this pin enables all receivers. When $\overline{G} = \text{high}$ and $G = \text{low}$ , all receivers are shut down, and the outputs go high impedance.
13	Y4	Receiver Output. Same functionality as Y1.
14	A4	Noninverting Receiver Input
15	B4	Inverting Receiver Input
16	$V_{CC}$	Positive Supply

# ±15kV ESD-Protected, 10Mbps, 3V/5V, Quad RS-422/RS-485 Receivers

**MAX3095/MAX3096**

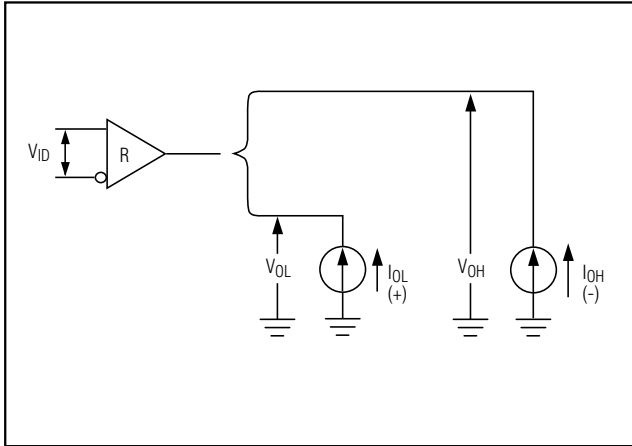

Figure 1. Receiver  $V_{OH}$  and  $V_{OL}$

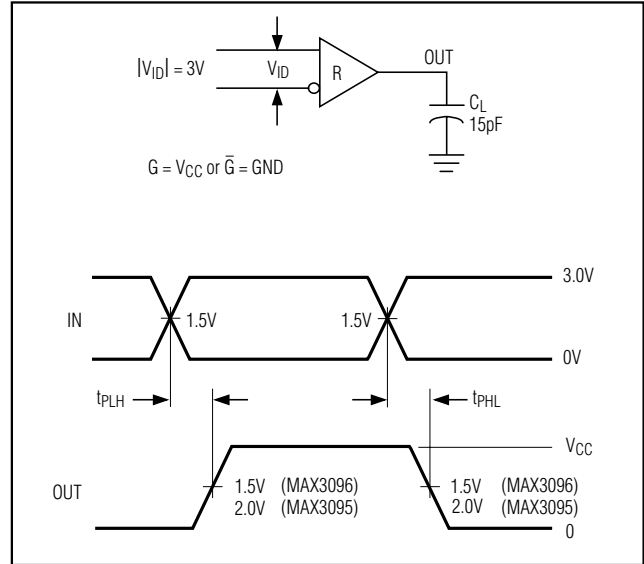

Figure 2. Receiver Propagation Delay

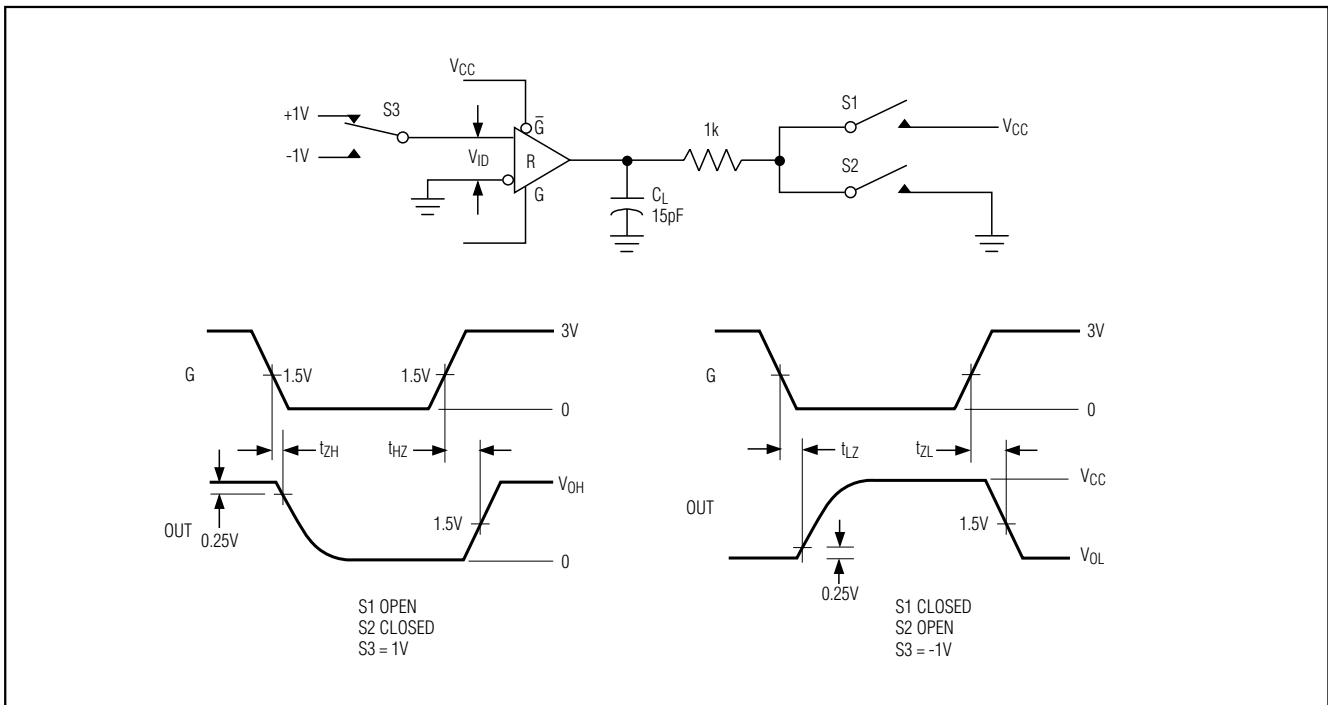

Figure 3. Receiver Enable and Disable Times

# ±15kV ESD-Protected, 10Mbps, 3V/5V, Quad RS-422/RS-485 Receivers

## Detailed Description

### ±15kV ESD Protection

As with all Maxim devices, ESD-protection structures are incorporated on all pins to protect against electrostatic discharges (ESD) encountered during handling and assembly. The MAX3095/MAX3096 receiver inputs have extra protection against static electricity found in normal operation. Maxim's engineers developed state-of-the-art structures to protect these pins against ±15kV ESD, without damage. After an ESD event, the MAX3095/MAX3096 continue working without latchup.

ESD protection can be tested in several ways. The receiver inputs are characterized for protection to the following:

- 1) ±15kV using the Human Body Model
- 2) ±8kV using the Contact-Discharge Method specified in IEC 1000-4-2 (formerly IEC 801-2)
- 3) ±15kV using the Air-Gap Method specified in IEC 1000-4-2 (formerly IEC 801-2)

### ESD Test Conditions

ESD performance depends on a number of conditions. Contact Maxim for a reliability report that documents test setup, methodology, and results.

### Human Body Model

Figure 4a shows the Human Body Model, and Figure 4b shows the current waveform it generates when discharged into a low impedance. This model consists of a 100pF capacitor charged to the ESD voltage of interest, which is then discharged into the device through a 1.5kΩ resistor.

### IEC 1000-4-2

Since January 1996, all equipment manufactured and/or sold in the European community has been required to meet the stringent IEC 1000-4-2 specification. The IEC 1000-4-2 standard covers ESD testing and performance of finished equipment; it does not specifically refer to integrated circuits. The MAX3095/MAX3096 help you design equipment that meets Level 4 (the highest level) of IEC 1000-4-2, without additional ESD-protection components.

The main difference between tests done using the Human Body Model and IEC 1000-4-2 is higher peak current in IEC 1000-4-2. Because series resistance is lower in the IEC 1000-4-2 ESD test model (Figure 5a), the ESD-withstand voltage measured to this standard is generally lower than that measured using the Human Body Model. Figure 5b shows the current waveform for the ±8kV IEC 1000-4-2 Level 4 ESD Contact-Discharge test. The Air-Gap test involves approaching the device with a charge probe. The Contact-Discharge method connects the probe to the device before the probe is energized.

### Machine Model

The Machine Model for ESD testing uses a 200pF storage capacitor and zero-discharge resistance. It mimics the stress caused by handling during manufacturing and assembly. Of course, all pins (not just RS-485 inputs) require this protection during manufacturing. Therefore, the Machine Model is less relevant to the I/O ports than are the Human Body Model and IEC 1000-4-2.

### Low-Power Shutdown Mode

Table 1 shows the functionality of the enable inputs. The MAX3095/MAX3096 enter shutdown when G is low and  $\overline{G}$  is high. In shutdown, all outputs go high impedance and the devices typically draw less than 1nA. The devices exit shutdown by taking G high or  $\overline{G}$  low. The typical shutdown exit time is 600ns.

Table 1. Function Table

G	$\overline{G}$	(A - B)	OUTPUT Y	DEVICE MODE
1	X	≥ 200mV	1	On
1	X	≤ -200mV	0	On
1	X	Open	1	On
X	0	≥ 200mV	1	On
X	0	≤ -200mV	0	On
X	0	Open	1	On
0	1	X	High-Z	Shutdown

X = don't care, High-Z = high impedance



# ±15kV ESD-Protected, 10Mbps, 3V/5V, Quad RS-422/RS-485 Receivers

MAX3095/MAX3096

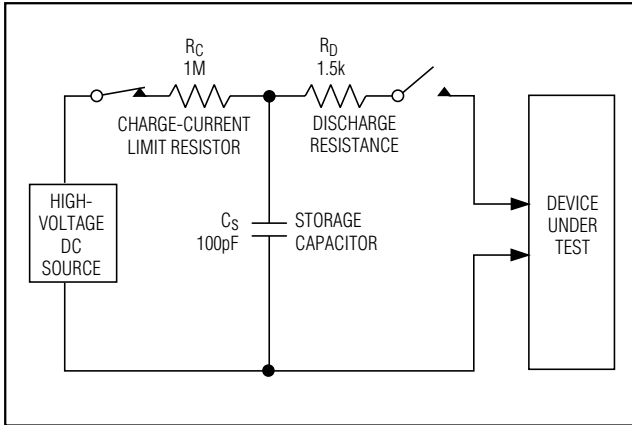

Figure 4a. Human Body ESD Test Model

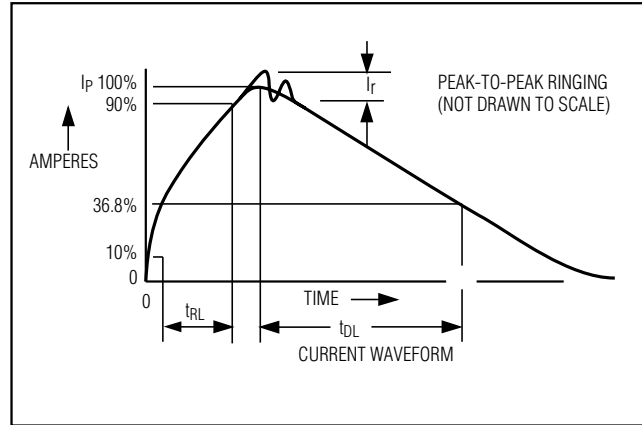

Figure 4b. Human Body Model Current Waveform

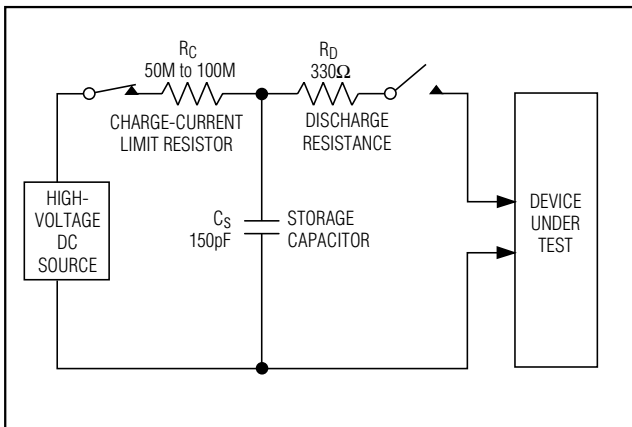

Figure 5a. IEC 1000-4-2 ESD Test Model

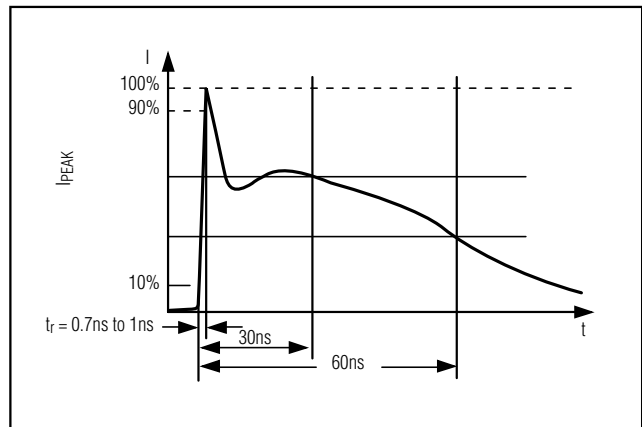

Figure 5b. IEC 1000-4-2 ESD-Generator Current Waveform

# ±15kV ESD-Protected, 10Mbps, 3V/5V, Quad RS-422/RS-485 Receivers

## Applications Information

### Propagation-Delay Matching

The MAX3095/MAX3096 exhibit propagation delays that are closely matched from one device to another, even between devices from different production lots. This feature allows multiple data lines to receive data and clock signals with minimal skewing with respect to each other. The MAX3095 receiver propagation delays are trimmed to a predetermined value  $\pm 8\text{ns}$ , while the MAX3096 delays are trimmed to a predetermined value  $\pm 10\text{ns}$ .

### 128 Receivers on the Bus

The standard RS-485 input impedance is  $12\text{k}\Omega$  (one-unit load). The standard RS-485 transmitter can drive 32 unit loads. The MAX3095/MAX3096 present a 1/4-unit-load input impedance ( $48\text{k}\Omega$ ), which allows up to 128 receivers on a bus. Any combination of these RS-485 receivers with a total of 32 unit loads can be connected to the same bus.

### Fail-Safe Implementation

The MAX3095/MAX3096 receiver inputs guarantee a logic high output when the inputs are open circuit (no termination resistor used). This occurs when the transmitter is removed from the bus or when all transmitter outputs are high impedance. However, when the line is terminated and the transmitters are disabled, the differential voltage between the A and B inputs falls below the  $\pm 200\text{mV}$  RS-485 sensitivity threshold. Consequently, the outputs become undefined. To maintain a fail-safe receiver output while using a terminating resistor, input A must be biased at least  $200\text{mV}$  above input B. The resistor-divider network shown in Figure 6 is recommended.

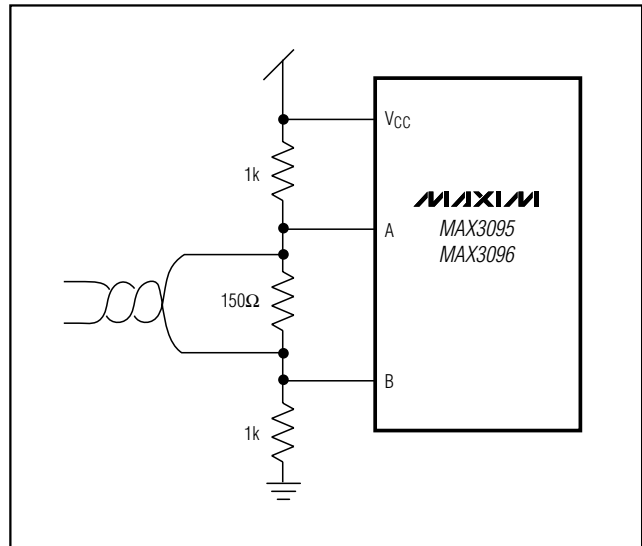

Figure 6. External Fail-Safe Implementation

## Chip Information

TRANSISTOR COUNT: 676

# ±15kV ESD-Protected, 10Mbps, 3V/5V, Quad RS-422/RS-485 Receivers

## Package Information

MAX3095/MAX3096

QSOP-EP5

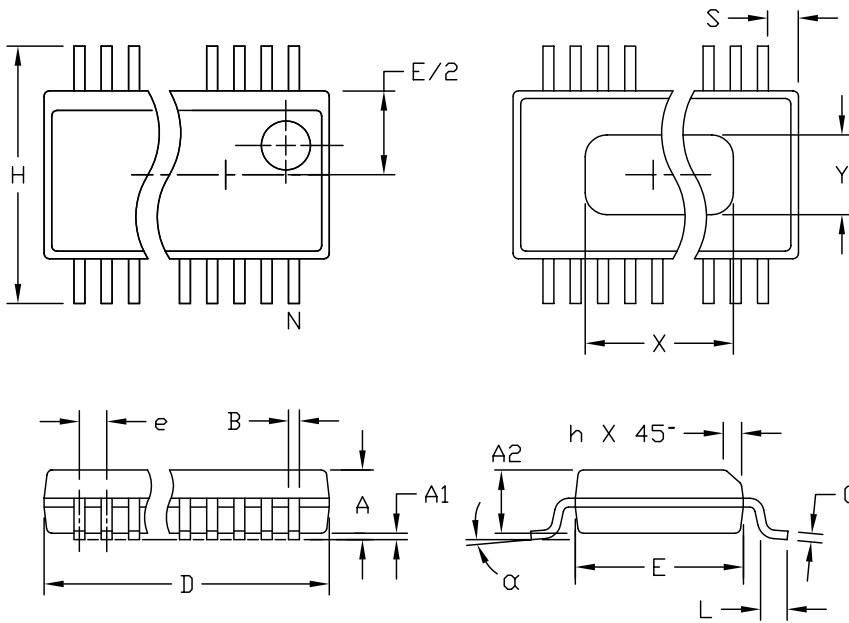

DIM	INCHES		MILLIMETERS	
	MIN	MAX	MIN	MAX
A	.061	.068	1.55	1.73
A1	.004	.0098	0.102	0.249
A2	.055	.061	1.40	1.55
B	.008	.012	0.20	0.31
C	.0075	.0098	0.191	0.249
D	SEE VARIATIONS			
E	.150	.157	3.81	3.99
e	.025 BSC		0.635 BSC	
H	.230	.244	5.84	6.20
h	.010	.016	0.25	0.41
L	.016	.035	0.41	0.89
N	SEE VARIATIONS			
X	SEE VARIATIONS			
Y	.071	.087	1.803	2.209
α	0°	8°	0°	8°

### VARIATIONS:

DIM	INCHES		MILLIMETERS		N
	MIN.	MAX.	MIN.	MAX.	
D	.189	.196	4.80	4.98	16 AA
S	.0020	.0070	0.05	0.18	
X	.107	.123	2.72	3.12	
D	.337	.344	8.56	8.74	20 AB
S	.0500	.0550	1.270	1.397	
D	.337	.344	8.56	8.74	24 AC
S	.0250	.0300	0.635	0.762	
D	.386	.393	9.80	9.98	28 AD
S	.0250	.0300	0.635	0.762	
X	.271	.287	6.88	7.29	

### NOTES:

1. D & E DO NOT INCLUDE MOLD FLASH OR PROTRUSIONS.
2. MOLD FLASH OR PROTRUSIONS NOT TO EXCEED .006" PER SIDE.
3. HEAT SLUG DIMENSIONS X AND Y APPLY ONLY TO 16 AND 28 LEAD POWER-QSOP PACKAGES.
4. CONTROLLING DIMENSIONS: INCHES.
5. MEETS JEDEC MO137.

**MAXIM**

PROPRIETARY INFORMATION

TITLE: PACKAGE OUTLINE, QSOP, 150°, .025" LEAD PITCH

APPROVAL	DOCUMENT CONTROL NO.	REV	1/1
	21-0055	C	

# ±15kV ESD-Protected, 10Mbps, 3V/5V, Quad RS-422/RS-485 Receivers

## Package Information (continued)

INCHES		MILLIMETERS		
MIN	MAX	MIN	MAX	
A	0.053	0.069	1.35	1.75
A1	0.004	0.010	0.10	0.25
B	0.014	0.019	0.35	0.49
C	0.007	0.010	0.19	0.25
e	0.050			1.27
E	0.150	0.157	3.80	4.00
H	0.228	0.244	5.80	6.20
h	0.010	0.020	0.25	0.50
L	0.016	0.050	0.40	1.27

INCHES		MILLIMETERS		N	MS012	
MIN	MAX	MIN	MAX			
D	0.189	0.197	4.80	5.00	8	A
D	0.337	0.344	8.55	8.75	14	B
D	0.386	0.394	9.80	10.00	16	C

NOTES:  
 1. D&E DO NOT INCLUDE MOLD FLASH  
 2. MOLD FLASH OR PROTRUSIONS NOT TO EXCEED .15mm (.006")  
 3. LEADS TO BE COPLANAR WITHIN .102mm (.004")  
 4. CONTROLLING DIMENSION: MILLIMETER  
 5. MEETS JEDEC MS012-XX AS SHOWN IN ABOVE TABLE  
 6. N = NUMBER OF PINS

**MAXIM** PACKAGE FAMILY OUTLINE: SOIC .150° 1/1 21-0041 A

INCHES		MILLIMETERS		
MIN	MAX	MIN	MAX	
A	---	0.200	---	5.08
A1	0.015	---	0.38	---
A2	0.125	0.175	3.18	4.45
A3	0.055	0.080	1.40	2.03
B	0.016	0.022	0.41	0.56
B1	0.045	0.065	1.14	1.65
C	0.008	0.012	0.20	0.30
D1	0.005	0.080	0.13	2.03
E	0.300	0.325	7.62	8.26
E1	0.240	0.310	6.10	7.87
e	0.100	---	2.54	---
eA	0.300	---	7.62	---
eB	---	0.400	---	10.16
L	0.115	0.150	2.92	3.81

INCHES		MILLIMETERS		N	MS001	
MIN	MAX	MIN	MAX			
D	0.348	0.390	8.84	9.91	8	AB
D	0.735	0.765	18.67	19.43	14	AC
D	0.745	0.765	18.92	19.43	16	AA
D	0.885	0.915	22.48	23.24	18	AD
D	1.015	1.045	25.78	26.54	20	AE
D	1.14	1.265	28.96	32.13	24	AF
D	1.360	1.380	34.54	35.05	28	*S

NOTES:  
 1. D&E DO NOT INCLUDE MOLD FLASH  
 2. MOLD FLASH OR PROTRUSIONS NOT TO EXCEED .15mm (.006")  
 3. CONTROLLING DIMENSION: MILLIMETER  
 4. MEETS JEDEC MS001-XX AS SHOWN IN ABOVE TABLE  
 5. SIMILAR TO JEDEC MO-058AB  
 6. N = NUMBER OF PINS

**MAXIM** PACKAGE FAMILY OUTLINE: PDIP .300° 1/1 21-0043 A

Maxim cannot assume responsibility for use of any circuitry other than circuitry entirely embodied in a Maxim product. No circuit patent licenses are implied. Maxim reserves the right to change the circuitry and specifications without notice at any time.

12 **Maxim Integrated Products, 120 San Gabriel Drive, Sunnyvale, CA 94086 408-737-7600**