

- Low Supply-Voltage Range, 1.8 V to 3.6 V
- Ultralow-Power Consumption:
 - Active Mode: 270 μ A at 1 MHz, 2.2 V
 - Standby Mode: 0.7 μ A
 - Off Mode (RAM Retention): 0.1 μ A
- Ultrafast Wake-Up From Standby Mode in Less Than 1 μ s
- 16-Bit RISC Architecture, 62.5 ns Instruction Cycle Time
- Hardware Multiplier
- Basic Clock Module Configurations:
 - Internal Frequencies up to 16MHz With Four Calibrated Frequencies to \pm 1%
 - Internal Very Low Power LF Oscillator
 - 32-kHz Crystal
 - High-Frequency Crystal up to 16 MHz
 - Resonator
 - External Digital Clock Source
 - External Resistor
- 16-Bit Timer_A With Three Capture/Compare Registers
- 16-Bit Timer_B With Three Capture/Compare Registers
- On-Chip Comparator for Analog Signal Compare Function or Slope A/D Conversion
- Universal Serial Communication Interface
 - Enhanced UART Supporting Auto Baudrate Detection (LIN)
 - IrDA Encoder and Decoder
 - Synchronous SPI
 - I²C™
- Brownout Detector
- Serial Onboard Programming, No External Programming Voltage Needed
- Programmable Code Protection by Security Fuse
- Bootstrap Loader in Flash Devices
- On-Chip Emulation Module
- Family Members Include:
 - MSP430F2330
 - 8KB + 256B Flash Memory
 - 1KB RAM
 - MSP430F2350
 - 16KB + 256B Flash Memory
 - 2KB RAM
 - MSP430F2370
 - 32KB + 256B Flash Memory
 - 2KB RAM
- Available in 40-pin QFN Package
- For Complete Module Descriptions, See the *MSP430x2xx Family User's Guide*

description

The Texas Instruments MSP430 family of ultralow-power microcontrollers consists of several devices featuring different sets of peripherals targeted for various applications. The architecture, combined with five low-power modes is optimized to achieve extended battery life in portable measurement applications. The devices feature a powerful 16-bit RISC CPU, 16-bit registers, and constant generators that contribute to maximum code efficiency. The digitally controlled oscillator (DCO) allows wake-up from low-power modes to active mode in less than 1 μ s.

The MSP430F23x0 series is an ultralow-power microcontroller with two built-in 16-bit timers, one universal serial communication interface (USCI), a versatile analog comparator, and 32 I/O pins.



This integrated circuit can be damaged by ESD. Texas Instruments recommends that all integrated circuits be handled with appropriate precautions. Failure to observe proper handling and installation procedures can cause damage. ESD damage can range from subtle performance degradation to complete device failure. Precision integrated circuits may be more susceptible to damage because very small parametric changes could cause the device not to meet its published specifications. These devices have limited built-in ESD protection.



Please be aware that an important notice concerning availability, standard warranty, and use in critical applications of Texas Instruments semiconductor products and disclaimers thereto appears at the end of this data sheet.

PRODUCTION DATA information is current as of publication date. Products conform to specifications per the terms of Texas Instruments standard warranty. Production processing does not necessarily include testing of all parameters.



MSP430F23x0 MIXED SIGNAL MICROCONTROLLER

SLAS518A - AUGUST 2006 - REVISED MAY 2007

AVAILABLE OPTIONS

T _A	PACKAGED DEVICES
	PLASTIC 40-PIN QFN (RHA)
-40°C to 85°C	MSP430F2330IRHA MSP430F2350IRHA MSP430F2370IRHA
-40°C to 105°C	MSP430F2330TRHA MSP430F2350TRHA MSP430F2370TRHA

pin designation, MSP430F23x0

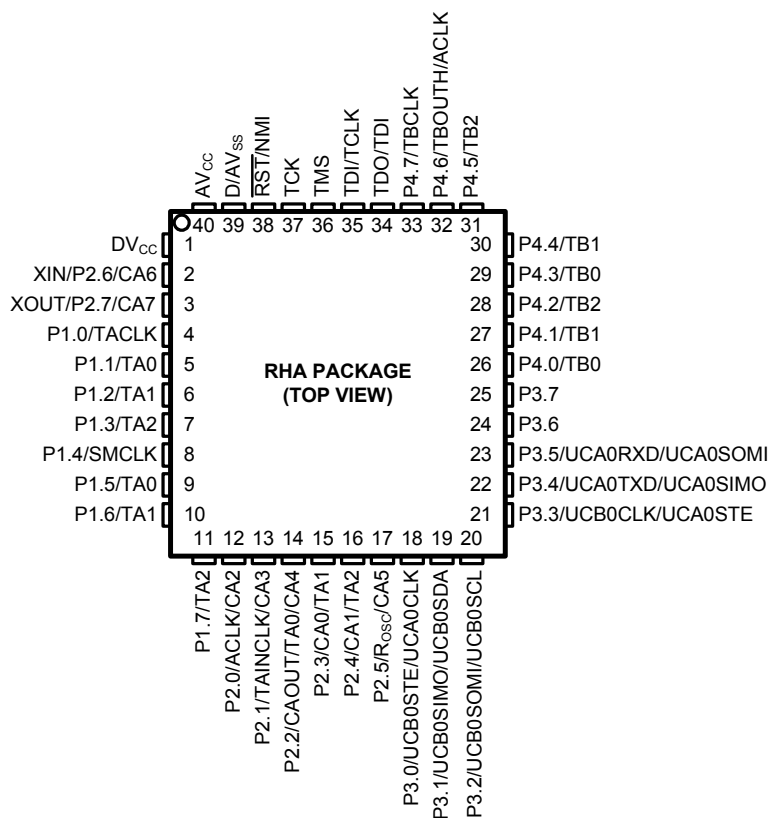

MSP430F23x0 MIXED SIGNAL MICROCONTROLLER

SLAS518A - AUGUST 2006 - REVISED MAY 2007

functional block diagram

MSP430F23x0

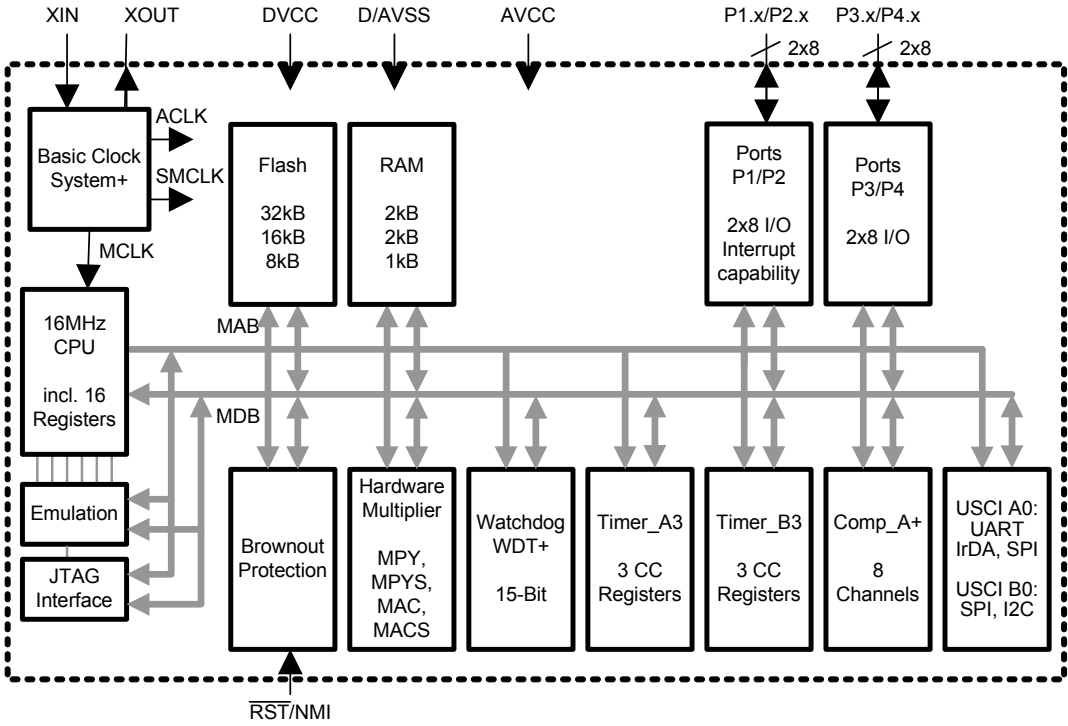

MSP430F23x0 MIXED SIGNAL MICROCONTROLLER

SLAS518A - AUGUST 2006 - REVISED MAY 2007

Terminal Functions, MSP430F23x0

TERMINAL			DESCRIPTION
NAME	NO	I/O	
DV _{CC}	1		Digital supply voltage, positive terminal. Supplies all digital parts.
XIN/P2.6/CA6	2	I/O	Input terminal of crystal oscillator/general-purpose digital I/O pin/Comparator_A input
XOUT/P2.7/CA7	3	I/O	Output terminal of crystal oscillator/general-purpose digital I/O pin/Comparator_A input
P1.0/TACLK	4	I/O	General-purpose digital I/O pin/Timer_A, clock signal TACLK input
P1.1/TA0	5	I/O	General-purpose digital I/O pin/Timer_A, capture: CCI0A input, compare: Out0 output
P1.2/TA1	6	I/O	General-purpose digital I/O pin/Timer_A, capture: CCI1A input, compare: Out1 output
P1.3/TA2	7	I/O	General-purpose digital I/O pin/Timer_A, capture: CCI2A input, compare: Out2 output
P1.4/SMCLK	8	I/O	General-purpose digital I/O pin/SMCLK signal output
P1.5/TA0	9	I/O	General-purpose digital I/O pin/Timer_A, compare: Out0 output
P1.6/TA1	10	I/O	General-purpose digital I/O pin/Timer_A, compare: Out1 output
P1.7/TA2	11	I/O	General-purpose digital I/O pin/Timer_A, compare: Out2 output
P2.0/ACLK/CA2	12	I/O	General-purpose digital I/O pin/ACLK output/Comparator_A input
P2.1/TAINCLK/CA3	13	I/O	General-purpose digital I/O pin/Timer_A, clock signal at INCLK/Comparator_A input
P2.2/CAOUT/TA0/CA4	14	I/O	General-purpose digital I/O pin/Comparator_A output/Timer_A, capture: CCI0B input/Comparator_A input
P2.3/CA0/TA1	15	I/O	General-purpose digital I/O pin/Comparator_A input/Timer_A, compare: Out1 output
P2.4/CA1/TA2	16	I/O	General-purpose digital I/O pin/Comparator_A input/Timer_A, compare: Out2 output
P2.5/R _{OSC} /CA5	17	I/O	General-purpose digital I/O pin/input for external resistor defining the DCO nominal frequency/Comparator_A input
P3.0/UCB0STE/ UCA0CLK	18	I/O	General-purpose digital I/O pin/USCIB0 slave transmit enable/USCIA0 clock input/output
P3.1/UCB0SIMO/ UCB0SDA	19	I/O	General-purpose digital I/O pin/USCIB0 slave in/master out in SPI mode, SDA I ² C data in I ² C mode
P3.2/UCB0SOMI/ UCB0SCL	20	I/O	General-purpose digital I/O pin/USCIB0 slave out/master in in SPI mode, SCL I ² C clock in I ² C mode
P3.3/UCB0CLK/ UCA0STE	21	I/O	General-purpose digital I/O pin/USCIB0 clock input/output, USCIA0 slave transmit enable
P3.4/UCA0TXD/ UCA0SIMO	22	I/O	General-purpose digital I/O pin/USCIA0 transmit data output in UART mode, slave data in/master out in SPI mode
P3.5/UCA0RXD/ UCA0SOMI	23	I/O	General-purpose digital I/O pin/USCIA0 receive data input in UART mode, slave data out/master in in SPI mode
P3.6	24	I/O	General-purpose digital I/O pin
P3.7	25	I/O	General-purpose digital I/O pin
P4.0/TB0	26	I/O	General-purpose digital I/O pin/Timer_B, capture: CCI0A input, compare: Out0 output
P4.1/TB1	27	I/O	General-purpose digital I/O pin/Timer_B, capture: CCI1A input, compare: Out1 output
P4.2/TB2	28	I/O	General-purpose digital I/O pin/Timer_B, capture: CCI2A input, compare: Out2 output
P4.3/TB0	29	I/O	General-purpose digital I/O pin/Timer_B, capture: CCI0B input, compare: Out0 output
P4.4/TB1	30	I/O	General-purpose digital I/O pin/Timer_B, capture: CCI1B input, compare: Out1 output
P4.5/TB2	31	I/O	General-purpose digital I/O pin/Timer_B, compare: Out2 output
P4.6/TBOUTH/ACLK	32	I/O	General-purpose digital I/O pin/switch all PWM digital outputs to high impedance - Timer_B3: TB0 to TB2/ACLK output
P4.7/TBCLK	33	I/O	General-purpose digital I/O pin/input clock TBCLK - Timer_B3
TDO/TDI	34	I/O	Test data output port. TDO/TDI data output or programming data input terminal
TDI/TCLK	35	I	Test data input or test clock input. The device protection fuse is connected to TDI/TCLK.
TMS	36	I	Test mode select. TMS is used as an input port for device programming and test.



Terminal Functions (Continued)

TERMINAL			DESCRIPTION
NAME	NO	I/O	
TCK	37	I	Test clock. TCK is the clock input port for device programming and test.
RST/NMI	38	I	Reset input, nonmaskable interrupt input port
D/AV _{SS}	39		Digital/Analog supply voltage, negative terminal
AV _{CC}	40		Analog supply voltage, positive terminal
QFN Pad	NA	NA	QFN package pad connection to D/AV _{SS} recommended

MSP430F23x0 MIXED SIGNAL MICROCONTROLLER

SLAS518A - AUGUST 2006 - REVISED MAY 2007

short-form description

CPU

The MSP430 CPU has a 16-bit RISC architecture that is highly transparent to the application. All operations, other than program-flow instructions, are performed as register operations in conjunction with seven addressing modes for source operand and four addressing modes for destination operand.

The CPU is integrated with 16 registers that provide reduced instruction execution time. The register-to-register operation execution time is one cycle of the CPU clock.

Four of the registers, R0 to R3, are dedicated as program counter, stack pointer, status register, and constant generator respectively. The remaining registers are general-purpose registers.

Peripherals are connected to the CPU using data, address, and control buses, and can be handled with all instructions.

instruction set

The instruction set consists of 51 instructions with three formats and seven address modes. Each instruction can operate on word and byte data. Table 1 shows examples of the three types of instruction formats; the address modes are listed in Table 2.

Program Counter	PC/R0
Stack Pointer	SP/R1
Status Register	SR/CG1/R2
Constant Generator	CG2/R3
General-Purpose Register	R4
General-Purpose Register	R5
General-Purpose Register	R6
General-Purpose Register	R7
General-Purpose Register	R8
General-Purpose Register	R9
General-Purpose Register	R10
General-Purpose Register	R11
General-Purpose Register	R12
General-Purpose Register	R13
General-Purpose Register	R14
General-Purpose Register	R15

Table 1. Instruction Word Formats

Dual operands, source-destination	e.g. ADD R4,R5	R4 + R5 ---> R5
Single operands, destination only	e.g. CALL R8	PC -->(TOS), R8--> PC
Relative jump, un/conditional	e.g. JNE	Jump-on-equal bit = 0

Table 2. Address Mode Descriptions

ADDRESS MODE	S	D	SYNTAX	EXAMPLE	OPERATION
Register	●	●	MOV Rs,Rd	MOV R10,R11	R10 --> R11
Indexed	●	●	MOV X(Rn),Y(Rm)	MOV 2(R5),6(R6)	M(2+R5)--> M(6+R6)
Symbolic (PC relative)	●	●	MOV EDE,TONI		M(EDE) --> M(TONI)
Absolute	●	●	MOV &MEM,&TCDAT		M(MEM) --> M(TCDAT)
Indirect	●		MOV @Rn,Y(Rm)	MOV @R10,Tab(R6)	M(R10) --> M(Tab+R6)
Indirect autoincrement	●		MOV @Rn+,Rm	MOV @R10+,R11	M(R10) --> R11 R10 + 2--> R10
Immediate	●		MOV #X,TONI	MOV #45,TONI	#45 --> M(TONI)

NOTE : S = source D = destination



operating modes

The MSP430 has one active mode and five software selectable low-power modes of operation. An interrupt event can wake up the device from any of the five low-power modes, service the request and restore back to the low-power mode on return from the interrupt program.

The following six operating modes can be configured by software:

- Active mode (AM)
 - All clocks are active
- Low-power mode 0 (LPM0)
 - CPU is disabled
ACLK and SMCLK remain active, MCLK is disabled
- Low-power mode 1 (LPM1)
 - CPU is disabled
ACLK and SMCLK remain active, MCLK is disabled
DCO's dc-generator is disabled if DCO not used in active mode
- Low-power mode 2 (LPM2)
 - CPU is disabled
MCLK and SMCLK are disabled
DCO's dc-generator remains enabled
ACLK remains active
- Low-power mode 3 (LPM3)
 - CPU is disabled
MCLK and SMCLK are disabled
DCO's dc-generator is disabled
ACLK remains active
- Low-power mode 4 (LPM4)
 - CPU is disabled
ACLK is disabled
MCLK and SMCLK are disabled
DCO's dc-generator is disabled
Crystal oscillator is stopped

MSP430F23x0 MIXED SIGNAL MICROCONTROLLER

SLAS518A - AUGUST 2006 - REVISED MAY 2007

interrupt vector addresses

The interrupt vectors and the power-up starting address are located in the address range 0xFFFF-0xFFC0. The vector contains the 16-bit address of the appropriate interrupt-handler instruction sequence.

INTERRUPT SOURCE	INTERRUPT FLAG	SYSTEM INTERRUPT	WORD ADDRESS	PRIORITY
Power-up External Reset Watchdog Flash key violation PC out of range (see Note 1)	PORIFG RSTIFG WDTIFG KEYV (see Note 2)	Reset	0xFFFFE	31, highest
NMI Oscillator Fault Flash memory access violation	NMIIFG OFIFG ACCVIFG (see Notes 2 & 6)	(non)-maskable (non)-maskable (non)-maskable	0xFFFC	30
Timer_B3	TBCCR0 CCIFG (see Note 3)	maskable	0xFFFA	29
Timer_B3	TBCCR1 and TBCCR2, CCIFGs, TBIFG (see Notes 2 & 3)	maskable	0xFFFF8	28
Comparator_A+	CAIFG	maskable	0xFFFF6	27
Watchdog timer	WDTIFG	maskable	0xFFFF4	26
Timer_A3	TACCR0 CCIFG (see Note 3)	maskable	0xFFFF2	25
Timer_A3	TACCR1 CCIFG, TACCR2 CCIFG, TAIFG (see Notes 2 & 3)	maskable	0xFFFF0	24
USCI_A0/USCI_B0 Receive USCI_B0 I2C Status	UCA0RXIFG, UCB0RXIFG (see Note 2 and 4)	maskable	0xFFEE	23
USCI_A0/USCI_B0 Transmit USCI_B0 I2C Receive / Transmit	UCA0TXIFG, UCB0TXIFG (see Note 2 and 5)	maskable	0xFFEC	22
			0xFFEA	21
			0xFFE8	20
I/O port P2 (eight flags)	P2IFG.0 to P2IFG.7 (see Notes 2 & 3)	maskable	0xFFE6	19
I/O port P1 (eight flags)	P1IFG.0 to P1IFG.7 (see Notes 2 & 3)	maskable	0xFFE4	18
			0xFFE2	17
			0xFFE0	16
(see Note 7)			0xFFDE	15
(see Note 8)			0xFFDC-0xFFC0	14-0, lowest

- NOTES:
1. A reset is executed if the CPU tries to fetch instructions from within the module register memory address range (0x0000-0x01FF).
 2. Multiple source flags.
 3. Interrupt flags are located in the module.
 4. In SPI mode: UCB0RXIFG. In I2C mode: UCALIFG, UCNACKIFG, ICSTTIFG, UCSTPIFG.
 5. In UART/SPI mode: UCB0TXIFG. In I2C mode: UCB0RXIFG, UCB0TXIFG.
 6. Non-maskable: the individual interrupt-enable bit can disable an interrupt event, but the general-interrupt enable cannot. Non-maskable: neither the individual nor the general interrupt-enable bit will disable an interrupt event.
 7. This location is used as bootstrap loader security key (BSLSKEY). A 0xAA55 at this location disables the BSL completely. A zero (0h) disables the erasure of the flash if an invalid password is supplied.
 8. The interrupt vectors at addresses 0xFFDC to 0xFFC0 are not used in this device and can be used for regular program code if necessary.



special function registers

Most interrupt and module-enable bits are collected in the lowest address space. Special-function register bits not allocated to a functional purpose are not physically present in the device. This arrangement provides simple software access.

interrupt enable 1 and 2

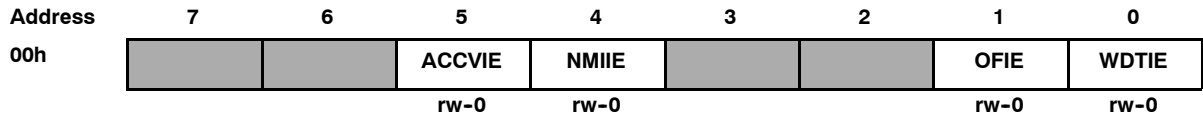

WDTIE Watchdog Timer interrupt enable. Inactive if watchdog mode is selected. Active if Watchdog Timer is configured in interval timer mode.

OFIE Oscillator fault enable

NMIIE (Non)maskable interrupt enable

ACCVIE Flash access violation interrupt enable

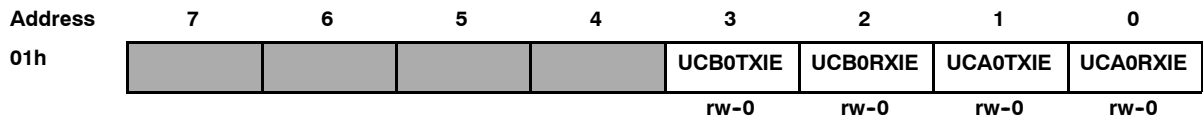

UCA0RXIE USCI_A0 receive-interrupt enable

UCA0TXIE USCI_A0 transmit-interrupt enable

UCB0RXIE USCI_B0 receive-interrupt enable

UCB0TXIE USCI_B0 transmit-interrupt enable

MSP430F23x0 MIXED SIGNAL MICROCONTROLLER

SLAS518A - AUGUST 2006 - REVISED MAY 2007

interrupt flag register 1 and 2

Address	7	6	5	4	3	2	1	0
02h				NMIIFG	RSTIFG	PORIFG	OFIFG	WDTIFG
				rw-0	rw-(0)	rw-(1)	rw-1	rw-(0)

- WDTIFG Set on Watchdog Timer overflow (in watchdog mode) or security key violation. Reset on V_{CC} power-up or a reset condition at \overline{RST}/NMI pin in reset mode.
- OFIFG Flag set on oscillator fault
- RSTIFG External reset interrupt flag. Set on a reset condition at \overline{RST}/NMI pin in reset mode. Reset on V_{CC} power up
- PORIFG Power-on interrupt flag. Set on V_{CC} power up.
- NMIIFG Set via \overline{RST}/NMI pin

Address	7	6	5	4	3	2	1	0
03h					UCB0TX IFG	UCB0RX IFG	UCA0TX IFG	UCA0RX IFG
					rw-0	rw-0	rw-0	rw-0

- UCA0RXIFG USCI_A0 receive-interrupt flag
- UCA0TXIFG USCI_A0 transmit-interrupt flag
- UCB0RXIFG USCI_B0 receive-interrupt flag
- UCB0TXIFG USCI_B0 transmit-interrupt flag

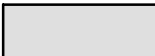
- Legend**
- rw: Bit can be read and written.
- rw-0,1: Bit can be read and written. It is Reset or Set by PUC.
- rw-(0,1): Bit can be read and written. It is Reset or Set by POR.
-  SFR bit is not present in device



memory organization

		MSP430F2330	MSP430F2350	MSP430F2370
Memory Main: interrupt vector Main: code memory	Size	8KB Flash	16KB Flash	32KB
	Flash	0xFFFF - 0xFFC0 0xFFFF - 0xE000	0xFFFF - 0xFFC0 0xFFFF - 0xC000	0xFFFF - 0xFFC0 0xFFFF - 0x8000
Information memory	Size	256 Byte	256 Byte	256 Byte
	Flash	0x10FF - 0x1000	0x10FF - 0x1000	0x10FF - 0x1000
Boot memory	Size	1KB	1KB	1KB
	ROM	0x0FFF - 0x0C00	0x0FFF - 0x0C00	0x0FFF - 0x0C00
RAM	Size	1KB Byte	2KB Byte	2KB
		0x5FF - 0x0200	0x9FF - 0x0200	0x09FF - 0x0200
Peripherals	16-bit	0x01FF - 0x0100	0x01FF - 0x0100	0x01FF - 0x0100
	8-bit	0x00FF - 0x0010	0x00FF - 0x0010	0x00FF - 0x0010
	8-bit SFR	0x000F - 0x0000	0x000F - 0x0000	0x000F - 0x0000

bootstrap loader (BSL)

The MSP430 bootstrap loader (BSL) enables users to program the flash memory or RAM using a UART serial interface. Access to the MSP430 memory via the BSL is protected by user-defined password. For complete description of the features of the BSL and its implementation, see the Application report *Features of the MSP430 Bootstrap Loader*, Literature Number SLAA089.

BSL Function	RHA Package Pins
Data Transmit	5 - P1.1
Data Receive	14 - P2.2

flash memory

The flash memory can be programmed via the JTAG port, the bootstrap loader, or in-system by the CPU. The CPU can perform single-byte and single-word writes to the flash memory. Features of the flash memory include:

- Flash memory has n segments of main memory and four segments of information memory (A to D) of 64 bytes each. Each segment in main memory is 512 bytes in size.
- Segments 0 to n may be erased in one step, or each segment may be individually erased.
- Segments A to D can be erased individually, or as a group with segments 0-n. Segments A to D are also called *information memory*.
- Segment A contains calibration data. After reset segment A is protected against programming or erasing. It can be unlocked but care should be taken not to erase this segment if the calibration data is required.

MSP430F23x0 MIXED SIGNAL MICROCONTROLLER

SLAS518A - AUGUST 2006 - REVISED MAY 2007

peripherals

Peripherals are connected to the CPU through data, address, and control busses and can be handled using all instructions. For complete module descriptions, refer to the *MSP430x2xx Family User's Guide*.

oscillator and system clock

The clock system is supported by the basic clock module that includes support for a 32768-Hz watch crystal oscillator, an internal very low power, low frequency oscillator, an internal digitally-controlled oscillator (DCO) and a high frequency crystal oscillator. The basic clock module is designed to meet the requirements of both low system cost and low-power consumption. The internal DCO provides a fast turn-on clock source and stabilizes in less than 1 μ s. The basic clock module provides the following clock signals:

- Auxiliary clock (ACLK), sourced from a 32768-Hz watch crystal, a high frequency crystal or the internal very low power LF oscillator.
- Main clock (MCLK), the system clock used by the CPU.
- Sub-Main clock (SMCLK), the sub-system clock used by the peripheral modules.

The DCO settings to calibrate the DCO output frequency are stored in the information memory segment A.

DCO Calibration Data (provided from factory in flash info memory segment A)			
DCO Frequency	Calibration Register	Size	Address
1 MHz	CALBC1_1MHZ	byte	0x10FF
	CALDCO_1MHZ	byte	0x10FE
8 MHz	CALBC1_8MHZ	byte	0x10FD
	CALDCO_8MHZ	byte	0x10FC
12 MHz	CALBC1_12MHZ	byte	0x10FB
	CALDCO_12MHZ	byte	0x10FA
16 MHz	CALBC1_16MHZ	byte	0x10F9
	CALDCO_16MHZ	byte	0x10F8

brownout

The brownout circuit is implemented to provide the proper internal reset signal to the device during power on and power off.

digital I/O

There are 4 8-bit I/O ports implemented—ports P1 through P4:

- All individual I/O bits are independently programmable.
- Any combination of input, output, and interrupt conditions is possible.
- Edge-selectable interrupt input capability for all the eight bits of ports P1 and P2.
- Read/write access to port-control registers is supported by all instructions.
- Each I/O has an individually programmable pull-up/pull-down resistor.

The MSP430F23x0 devices provide 32 total port I/O pins available externally. Please see the device pinout for more information.

watchdog timer +

The primary function of the watchdog timer (WDT+) module is to perform a controlled system restart after a software problem occurs. If the selected time interval expires, a system reset is generated. If the watchdog function is not needed in an application, the module can be configured as an interval timer and can generate interrupts at selected time intervals.



POST OFFICE BOX 655303 • DALLAS, TEXAS 75265

hardware multiplier

The multiplication operation is supported by a dedicated peripheral module. The module performs 16×16 , 16×8 , 8×16 , and 8×8 bit operations. The module is capable of supporting signed and unsigned multiplication as well as signed and unsigned multiply and accumulate operations. The result of an operation can be accessed immediately after the operands have been loaded into the peripheral registers. No additional clock cycles are required.

comparator_A+

The primary function of the comparator_A+ module is to support precision slope analog-to-digital conversions, battery-voltage supervision, and monitoring of external analog signals.

timer_A3

Timer_A3 is a 16-bit timer/counter with three capture/compare registers. Timer_A3 can support multiple capture/compares, PWM outputs, and interval timing. Timer_A3 also has extensive interrupt capabilities. Interrupts may be generated from the counter on overflow conditions and from each of the capture/compare registers.

Timer_A3 Signal Connections					
Input Pin Number	Device Input Signal	Module Input Name	Module Block	Module Output Signal	Output Pin Number
RHA					RHA
4 - P1.0	TACLK	TACLK	Timer	NA	
	ACLK	ACLK			
	SMCLK	SMCLK			
13 - P2.1	TAINCLK	INCLK			
5 - P1.1	TA0	CCI0A	CCR0	TA0	5 - P1.1
14 - P2.2	TA0	CCI0B			9 - P1.5
	V _{SS}	GND			
	V _{CC}	V _{CC}			
6 - P1.2	TA1	CCI1A	CCR1	TA1	6 - P1.2
	CAOUT (internal)	CCI1B			10 - P1.6
	V _{SS}	GND			15 - P2.3
	V _{CC}	V _{CC}			
7 - P1.3	TA2	CCI2A	CCR2	TA2	7 - P1.3
	ACLK (internal)	CCI2B			11 - P1.7
	V _{SS}	GND			16 - P2.4
	V _{CC}	V _{CC}			

MSP430F23x0 MIXED SIGNAL MICROCONTROLLER

SLAS518A - AUGUST 2006 - REVISED MAY 2007

timer_B3

Timer_B3 is a 16-bit timer/counter with three capture/compare registers. Timer_B3 can support multiple capture/compares, PWM outputs, and interval timing. Timer_B3 also has extensive interrupt capabilities. Interrupts may be generated from the counter on overflow conditions and from each of the capture/compare registers.

Timer_B3 Signal Connections					
Input Pin Number	Device Input Signal	Module Input Name	Module Block	Module Output Signal	Output Pin Number
RHA					RHA
33 - P4.7	TBCLK	TBCLK	Timer	NA	
	ACLK	ACLK			
	SMCLK	SMCLK			
	TBCLK	INCLK			
26 - P4.0	TB0	CCI0A	CCR0	TB0	26 - P4.0
29 - P4.3	TB0	CCI0B			29 - P4.3
	DV _{SS}	GND			
	DV _{CC}	V _{CC}			
27 - P4.1	TB1	CCI1A	CCR1	TB1	27 - P4.1
30 - P4.4	TB1	CCI1B			30 - P4.4
	DV _{SS}	GND			
	DV _{CC}	V _{CC}			
28 - P4.2	TB2	CCI2A	CCR2	TB2	28 - P4.2
	ACLK (internal)	CCI2B			31 - P4.5
	DV _{SS}	GND			
	DV _{CC}	V _{CC}			

USCI

The universal serial communication interface (USCI) module is used for serial data communication. The USCI module supports synchronous communication protocols like SPI (3 or 4 pin), I2C and asynchronous communication protocols like UART, enhanced UART with automatic baudrate detection (LIN), and IrDA.

USCI A0 provides support for SPI (3 or 4 pin), UART, enhanced UART and IrDA.

USCI B0 provides support for SPI (3 or 4 pin) and I2C.



peripheral file map

PERIPHERALS WITH WORD ACCESS			
Timer_B3	Capture/compare register	TBCCR2	0x0196
	Capture/compare register	TBCCR1	0x0194
	Capture/compare register	TBCCR0	0x0192
	Timer_B register	TBR	0x0190
	Capture/compare control	TBCCTL2	0x0186
	Capture/compare control	TBCCTL1	0x0184
	Capture/compare control	TBCCTL0	0x0182
	Timer_B control	TBCTL	0x0180
	Timer_B interrupt vector	TBIV	0x011E
Timer_A3	Capture/compare register	TACCR2	0x0176
	Capture/compare register	TACCR1	0x0174
	Capture/compare register	TACCR0	0x0172
	Timer_A register	TAR	0x0170
	Capture/compare control	TACCTL2	0x0166
	Capture/compare control	TACCTL1	0x0164
	Capture/compare control	TACCTL0	0x0162
	Timer_A control	TACTL	0x0160
	Timer_A interrupt vector	TAIV	0x012E
Flash Memory	Flash control 3	FCTL3	0x012C
	Flash control 2	FCTL2	0x012A
	Flash control 1	FCTL1	0x0128
Hardware Multiplier	Sum extend	SUMEXT	0x013E
	Result high word	RESHI	0x013C
	Result low word	RESLO	0x013A
	Second operand	OP2	0x0138
	Multiply signed +accumulate/operand1	MACS	0x0136
	Multiply+accumulate/operand1	MAC	0x0134
	Multiply signed/operand1	MPYS	0x0132
	Multiply unsigned/operand1	MPY	0x0130
Watchdog Timer+	Watchdog/timer control	WDTCTL	0x0120
PERIPHERALS WITH BYTE ACCESS			
USCI_B0	USCI_B0 transmit buffer	UCB0TXBUF	0x06F
	USCI_B0 receive buffer	UCB0RXBUF	0x06E
	USCI_B0 status	UCB0STAT	0x06D
	USCI_B0 bit rate control 1	UCB0BR1	0x06B
	USCI_B0 bit rate control 0	UCB0BR0	0x06A
	USCI_B0 control 1	UCB0CTL1	0x069
	USCI_B0 control 0	UCB0CTL0	0x068
	USCI_B0 I2C slave address	UCB0SA	0x011A
	USCI_B0 I2C own address	UCB0OA	0x0118
	USCI_A0	USCI_A0 transmit buffer	UCA0TXBUF
USCI_A0 receive buffer		UCA0RXBUF	0x0066
USCI_A0 status		UCA0STAT	0x0065
USCI_A0 modulation control		UCA0MCTL	0x0064
USCI_A0 baud rate control 1		UCA0BR1	0x0063
USCI_A0 baud rate control 0		UCA0BR0	0x0062
USCI_A0 control 1		UCA0CTL1	0x0061
USCI_A0 control 0		UCA0CTL0	0x0060
USCI_A0 IrDA receive control		UCA0IRRCTL	0x005F
USCI_A0 IrDA transmit control		UCA0IRTCTL	0x005E
USCI_A0 auto baud rate control		UCA0ABCTL	0x005D

MSP430F23x0 MIXED SIGNAL MICROCONTROLLER

SLAS518A - AUGUST 2006 - REVISED MAY 2007

PERIPHERALS WITH BYTE ACCESS (continued)			
Basic Clock System+	Basic clock system control 3 Basic clock system control 2 Basic clock system control 1 DCO clock frequency control	BCSCTL3 BCSCTL2 BCSCTL1 DCOCTL	0x0053 0x0058 0x0057 0x0056
Port P4	Port P4 resistor enable Port P4 selection Port P4 direction Port P4 output Port P4 input	P4REN P4SEL P4DIR P4OUT P4IN	0x0011 0x001F 0x001E 0x001D 0x001C
Port P3	Port P3 resistor enable Port P3 selection Port P3 direction Port P3 output Port P3 input	P3REN P3SEL P3DIR P3OUT P3IN	0x0010 0x001B 0x001A 0x0019 0x0018
Port P2	Port P2 resistor enable Port P2 selection Port P2 interrupt enable Port P2 interrupt edge select Port P2 interrupt flag Port P2 direction Port P2 output Port P2 input	P2REN P2SEL P2IE P2IES P2IFG P2DIR P2OUT P2IN	0x002F 0x002E 0x002D 0x002C 0x002B 0x002A 0x0029 0x0028
Port P1	Port P1 resistor enable Port P1 selection Port P1 interrupt enable Port P1 interrupt edge select Port P1 interrupt flag Port P1 direction Port P1 output Port P1 input	P1REN P1SEL P1IE P1IES P1IFG P1DIR P1OUT P1IN	0x0027 0x0026 0x0025 0x0024 0x0023 0x0022 0x0021 0x0020
Special Function	SFR interrupt flag 2 SFR interrupt flag 1 SFR interrupt enable 2 SFR interrupt enable 1	IFG2 IFG1 IE2 IE1	0x0003 0x0002 0x0001 0x0000



absolute maximum ratings (see Note 1)

Voltage applied at V_{CC} to V_{SS}	-0.3 V to + 4.1 V
Voltage applied to any pin (see Note 2)	-0.3 V to $V_{CC}+0.3$ V
Diode current at any device terminal	± 2 mA
Storage temperature (unprogrammed device, see Note 3)	-55°C to 150°C
Storage temperature (programmed device, see Note 3)	-40°C to 105°C

- NOTES: 1. Stresses beyond those listed under “absolute maximum ratings” may cause permanent damage to the device. These are stress ratings only, and functional operation of the device at these or any other conditions beyond those indicated under “recommended operating conditions” is not implied. Exposure to absolute-maximum-rated conditions for extended periods may affect device reliability.
2. All voltages referenced to V_{SS} . The JTAG fuse-blow voltage, V_{FB} , is allowed to exceed the absolute maximum rating. The voltage is applied to the TDI/TCLK pin when blowing the JTAG fuse.
3. Higher temperature may be applied during board soldering process according to the current JEDEC J-STD-020 specification with peak reflow temperatures not higher than classified on the device label on the shipping boxes or reels.

recommended operating conditions

PARAMETER		MIN	NOM	MAX	UNITS
Supply voltage during program execution, V_{CC}	$AV_{CC} = DV_{CC} = V_{CC}$ (see Note 1)	1.8		3.6	V
Supply voltage during flash memory programming, V_{CC}	$AV_{CC} = DV_{CC} = V_{CC}$ (see Note 1)	2.2		3.6	V
Supply voltage, V_{SS}	$AV_{SS} = DV_{SS} = V_{SS}$	0.0		0.0	V
Operating free-air temperature range, T_A	I Version	-40		85	°C
	T Version	-40		105	°C
Processor frequency f_{SYSTEM} (Maximum MCLK frequency) (see Notes 2, 3 and Figure 1)	$V_{CC} = 1.8$ V, Duty Cycle = 50% \pm 10%	dc		4.15	MHz
	$V_{CC} = 2.7$ V, Duty Cycle = 50% \pm 10%	dc		12	
	$V_{CC} \geq 3.3$ V, Duty Cycle = 50% \pm 10%	dc		16	

- NOTES: 1. It is recommended to power AV_{CC} and DV_{CC} from the same source. A maximum difference of 0.3 V between AV_{CC} and DV_{CC} can be tolerated during power-up and operation.
2. The MSP430 CPU is clocked directly with MCLK.
Both the high and low phase of MCLK must not exceed the pulse width of the specified maximum frequency.
3. Modules might have a different maximum input clock specification. See the specification of the respective module in this datasheet.

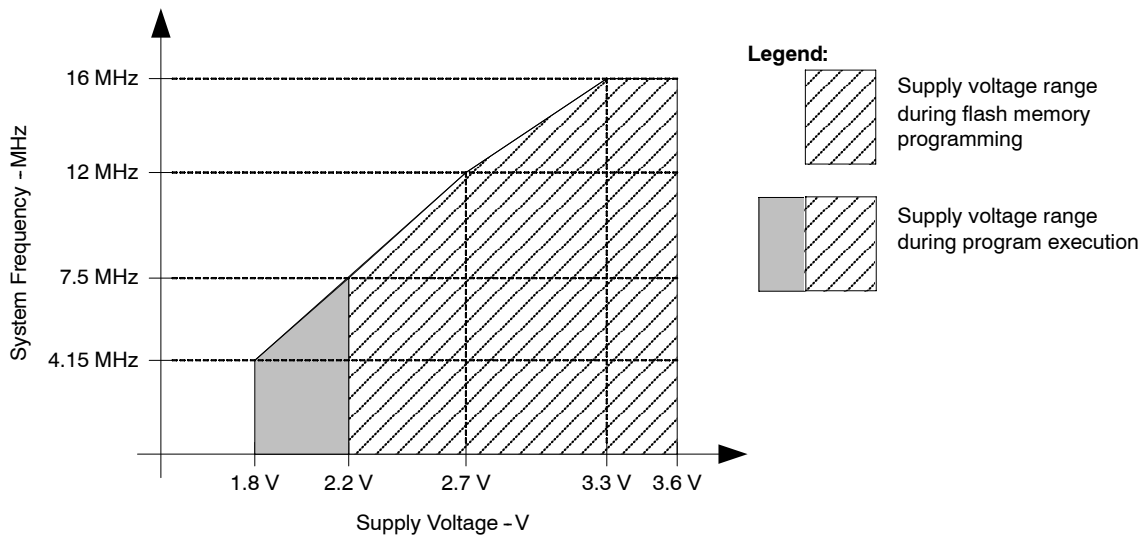

NOTE : Minimum processor frequency is defined by system clock. Flash program or erase operations require a minimum V_{CC} of 2.2 V.

Figure 1. Operating Area

MSP430F23x0

MIXED SIGNAL MICROCONTROLLER

SLAS518A - AUGUST 2006 - REVISED MAY 2007

electrical characteristics over recommended ranges of supply voltage and operating free-air temperature (unless otherwise noted)

active mode supply current (into V_{CC}) excluding external current (see Notes 1 and 2)

PARAMETER	TEST CONDITIONS	T_A	V_{CC}	MIN	TYP	MAX	UNIT
$I_{AM, 1MHz}$ Active mode (AM) current (1MHz)	$f_{DCO} = f_{MCLK} = f_{SMCLK} = 1MHz$, $f_{ACLK} = 32,768Hz$, Program executes from flash, BCSCTL1 = CALBC1_1MHz, DCOCTL = CALDCO_1MHz, CPUOFF = 0, SCG0 = 0, SCG1 = 0, OSCOFF = 0		2.2 V		270	370	μA
			3 V		390	550	
$I_{AM, 1MHz}$ Active mode (AM) current (1MHz)	$f_{DCO} = f_{MCLK} = f_{SMCLK} = 1MHz$, $f_{ACLK} = 32,768Hz$, Program executes in RAM, BCSCTL1 = CALBC1_1MHz, DCOCTL = CALDCO_1MHz, CPUOFF = 0, SCG0 = 0, SCG1 = 0, OSCOFF = 0		2.2 V		226		μA
			3 V		318		
$I_{AM, 4kHz}$ Active mode (AM) current (4kHz)	$f_{MCLK} = f_{SMCLK} =$ $f_{ACLK} = 32,768Hz/8 = 4,096Hz$, $f_{DCO} = 0Hz$, Program executes in flash, SELMx = 11, SELS = 1, DIVMx = DIVSx = DIVAx = 11, CPUOFF = 0, SCG0 = 1, SCG1 = 0, OSCOFF = 0	-40..85°C	2.2 V		2	6	μA
		105°C	2.2 V			14	
		-40..85°C	3 V		3	9	
		105°C	3 V			17	
$I_{AM, 100kHz}$ Active mode (AM) current (100kHz)	$f_{MCLK} = f_{SMCLK} = f_{DCO(0, 0)} \approx 100kHz$, $f_{ACLK} = 0Hz$, Program executes in flash, RSELx = 0, DCOx = 0, CPUOFF = 0, SCG0 = 0, SCG1 = 0, OSCOFF = 1	-40..85°C	2.2 V		60	85	μA
		105°C	2.2 V			95	
		-40..85°C	3 V		72	95	
		105°C	3 V			105	

- NOTES: 1. All inputs are tied to 0 V or V_{CC} . Outputs do not source or sink any current.
2. The currents are characterized with a Micro Crystal CC4V-T1A SMD crystal with a load capacitance of 9 pF. The internal and external load capacitance is chosen to closely match the required 9pF.

typical characteristics - active mode supply current (into DV_{CC} + AV_{CC})

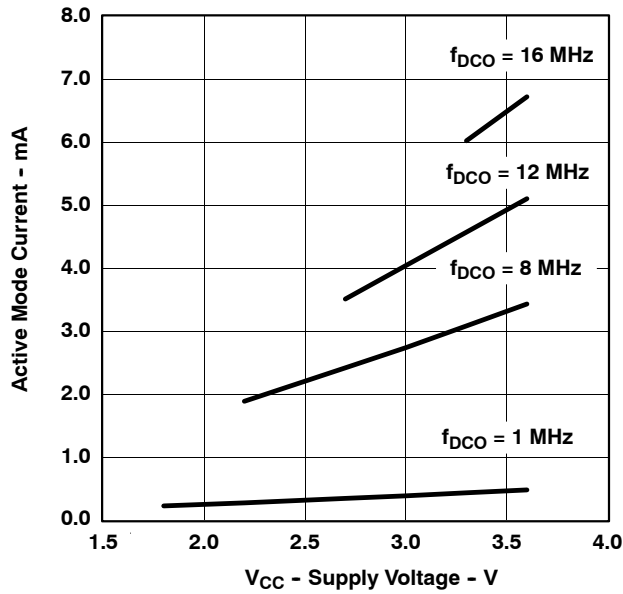

Figure 2. Active mode current vs V_{CC}, T_A = 25°C

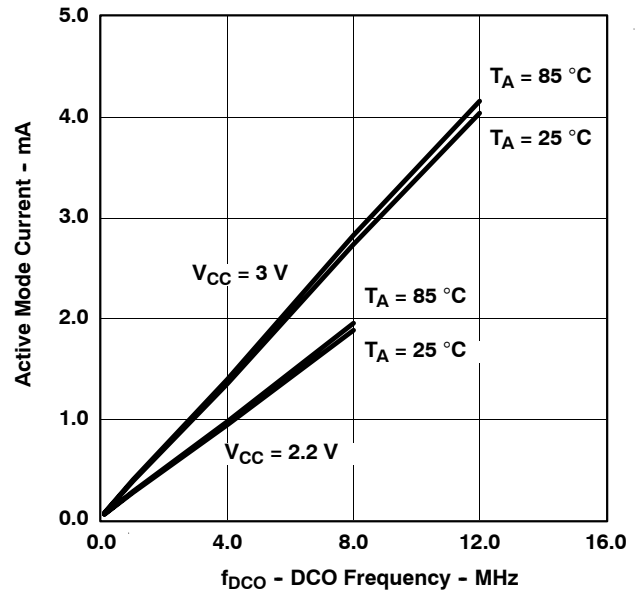

Figure 3. Active mode current vs DCO frequency

MSP430F23x0 MIXED SIGNAL MICROCONTROLLER

SLAS518A - AUGUST 2006 - REVISED MAY 2007

electrical characteristics over recommended ranges of supply voltage and operating free-air temperature (unless otherwise noted)

low power mode supply currents (into V_{CC}) excluding external current (see Notes 1 and 2)

PARAMETER	TEST CONDITIONS	VCC	MIN	TYP	MAX	UNIT
I _{LPM0, 1MHz} Low-power mode 0 (LPM0) current, see Note 3	f _{MCLK} = 0MHz, f _{SMCLK} = f _{DCO} = 1MHz, f _{ACLK} = 32,768Hz, BCSCTL1 = CALBC1_1MHZ, DCOCTL = CALDCO_1MHZ, CPUOFF = 1, SCG0 = 0, SCG1 = 0, OSCOFF = 0	2.2 V	T _A = -40..85°C	68	84	μA
			T _A = 105°C		90	μA
		3 V	T _A = -40..85°C	88	110	μA
			T _A = 105°C		115	μA
I _{LPM0, 100kHz} Low-power mode 0 (LPM0) current, see Note 3	f _{MCLK} = 0MHz, f _{SMCLK} = f _{DCO(0, 0)} = 100kHz, f _{ACLK} = 0Hz, RSELx = 0, DCOx = 0, CPUOFF = 1, SCG0 = 0, SCG1 = 0, OSCOFF = 1	2.2 V	T _A = -40..85°C	36	45	μA
			T _A = 105°C		50	μA
		3 V	T _A = -40..85°C	40	50	μA
			T _A = 105°C		54	μA
I _{LPM2} Low-power mode 2 (LPM2) current, see Note 4	f _{MCLK} = f _{SMCLK} = 0MHz, f _{DCO} = 1MHz, f _{ACLK} = 32,768Hz, BCSCTL1 = CALBC1_1MHZ, DCOCTL = CALDCO_1MHZ, CPUOFF = 1, SCG0 = 0, SCG1 = 1, OSCOFF = 0	2.2 V	T _A = -40..85°C	20	28	μA
			T _A = 105°C		32	μA
		3 V	T _A = -40..85°C	23	32	μA
			T _A = 105°C		37	μA
I _{LPM3, LFX1} Low-power mode 3 (LPM3) current, see Note 4	f _{DCO} = f _{MCLK} = f _{SMCLK} = 0MHz, f _{ACLK} = 32,768Hz, CPUOFF = 1, SCG0 = 1, SCG1 = 1, OSCOFF = 0	2.2 V	T _A = -40..25°C	0.7	1.0	μA
			T _A = 85°C		3.3	
			T _A = 105°C		10	
		3 V	T _A = -40..25°C	0.85	1.2	μA
			T _A = 85°C		3.8	
			T _A = 105°C		12	
I _{LPM3, VLO} Low-power mode 3 current, (LPM3) see Note 4	f _{DCO} = f _{MCLK} = f _{SMCLK} = 0MHz, f _{ACLK} from internal LF oscillator (VLO), CPUOFF = 1, SCG0 = 1, SCG1 = 1, OSCOFF = 0	2.2 V	T _A = -40..25°C	0.25	0.8	μA
			T _A = 85°C		2.9	
			T _A = 105°C		9	
		3 V	T _A = -40..25°C	0.35	1.0	μA
			T _A = 85°C		3.5	
			T _A = 105°C		11	
I _{LPM4} Low-power mode 4 (LPM4) current, see Note 5	f _{DCO} = f _{MCLK} = f _{SMCLK} = 0MHz, f _{ACLK} = 0Hz, CPUOFF = 1, SCG0 = 1, SCG1 = 1, OSCOFF = 1	2.2V	T _A = -40°C		0.5	μA
			T _A = 25°C		0.5	
			T _A = 85°C		1.7	
			T _A = 105°C		8.6	
		3V	T _A = -40°C		0.5	μA
			T _A = 25°C		0.5	
			T _A = 85°C	1.9	3	
			T _A = 105°C		9	

- NOTES: 1. All inputs are tied to 0 V or V_{CC}. Outputs do not source or sink any current.
 2. The currents are characterized with a Micro Crystal CC4V-T1A SMD crystal with a load capacitance of 9 pF. The internal and external load capacitance is chosen to closely match the required 9pF.
 3. Current for brownout and WDT clocked by SMCLK included.
 4. Current for brownout and WDT clocked by ACLK included.
 5. Current for brownout included.



electrical characteristics over recommended ranges of supply voltage and operating free-air temperature (unless otherwise noted)

Schmitt-trigger inputs - Ports P1, P2, P3 P4, JTAG, $\overline{\text{RST}}$ /NMI, and XIN (see Note)

PARAMETER	TEST CONDITIONS	VCC	MIN	TYP	MAX	UNIT
V_{IT+}	Positive-going input threshold voltage		0.45		0.75	V_{CC}
		2.2 V	1.00		1.65	V
		3 V	1.35		2.25	V
V_{IT-}	Negative-going input threshold voltage		0.25		0.55	V_{CC}
		2.2 V	0.55		1.20	V
		3 V	0.75		1.65	V
V_{hys}	Input voltage hysteresis ($V_{IT+} - V_{IT-}$)	2.2 V	0.2		1.0	V
		3 V	0.3		1.0	V
R_{Pull}	Pullup/pulldown resistor	For pullup: $V_{IN} = V_{SS}$; For pulldown: $V_{IN} = V_{CC}$	20	35	50	k Ω
C_I	Input capacitance	$V_{IN} = V_{SS}$ or V_{CC}		5		pF

NOTE : XIN only in bypass mode.

inputs - Ports P1, P2

PARAMETER	TEST CONDITIONS	VCC	MIN	TYP	MAX	UNIT
$t_{(int)}$	Port P1, P2: P1.x to P2.x, External trigger puls width to set interrupt flag, (see Note)	2.2 V/3 V	20			ns

NOTE : An external signal sets the interrupt flag every time the minimum interrupt puls width $t_{(int)}$ is met. It may be set even with trigger signals shorter than $t_{(int)}$.

leakage current - Ports P1, P2, P3 and P4

PARAMETER	TEST CONDITIONS	VCC	MIN	TYP	MAX	UNIT
$I_{lkq}(Px.x)$	High-impedance leakage current	see Notes 1 and 2			± 50	nA

NOTES: 1. The leakage current is measured with V_{SS} or V_{CC} applied to the corresponding pin(s), unless otherwise noted.
2. The leakage of the digital port pins is measured individually. The port pin is selected for input and the pull-up/pull-down resistor is disabled.

MSP430F23x0

MIXED SIGNAL MICROCONTROLLER

SLAS518A - AUGUST 2006 - REVISED MAY 2007

electrical characteristics over recommended ranges of supply voltage and operating free-air temperature (unless otherwise noted) (continued)

outputs - Ports P1, P2, P3 and P4

PARAMETER	TEST CONDITIONS	VCC	MIN	TYP	MAX	UNIT
V _{OH}	High-level output voltage	2.2 V	V _{CC} -0.25		V _{CC}	V
		2.2 V	V _{CC} -0.6	V _{CC}		
					3 V	
V _{OL}	Low-level output voltage	2.2 V	V _{SS}			V _{SS} +0.25
					3 V	
		2.2 V	V _{SS}	V _{SS}		V _{SS} +0.6
					3 V	

- NOTES: 1. The maximum total current, I_{OHmax} and I_{OLmax}, for all outputs combined, should not exceed ±12 mA to hold the maximum voltage drop specified.
 2. The maximum total current, I_{OHmax} and I_{OLmax}, for all outputs combined, should not exceed ±48 mA to hold the maximum voltage drop specified.

output frequency - Ports P1, P2, P3 and P4

PARAMETER	TEST CONDITIONS	VCC	MIN	TYP	MAX	UNIT
f _{Px.y}	Port output frequency (with load)	2.2 V			7.5	MHz
		3 V			12	MHz
f _{Port_CLK}	Clock output frequency	2.2 V			7.5	MHz
		3 V			16	MHz

- NOTES: 1. A resistive divider with 2 times 0.5 kΩ between V_{CC} and V_{SS} is used as load. The output is connected to the center tap of the divider.
 2. The output voltage reaches at least 10% and 90% V_{CC} at the specified toggle frequency.



electrical characteristics over recommended ranges of supply voltage and operating free-air temperature (unless otherwise noted) (continued)

typical characteristics - outputs

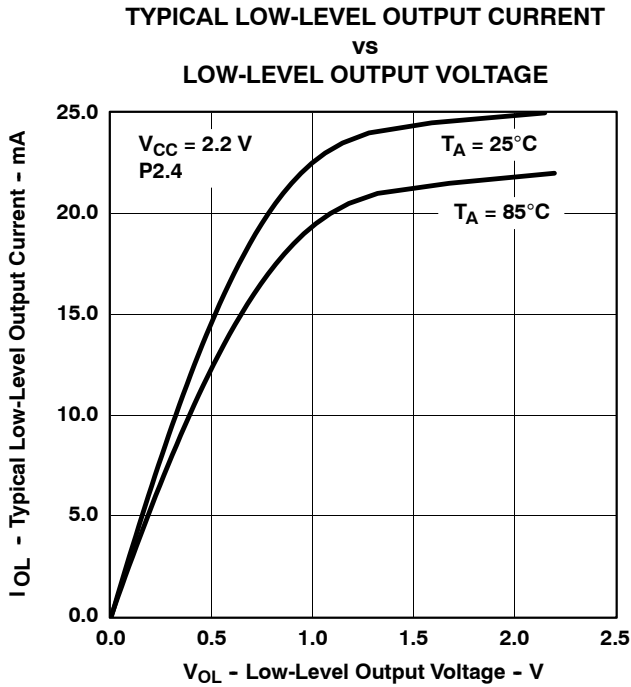

Figure 4

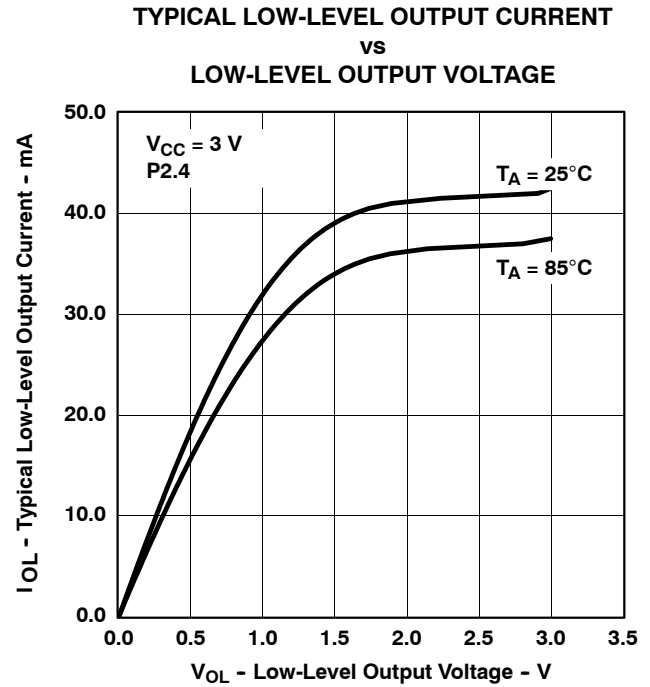

Figure 5

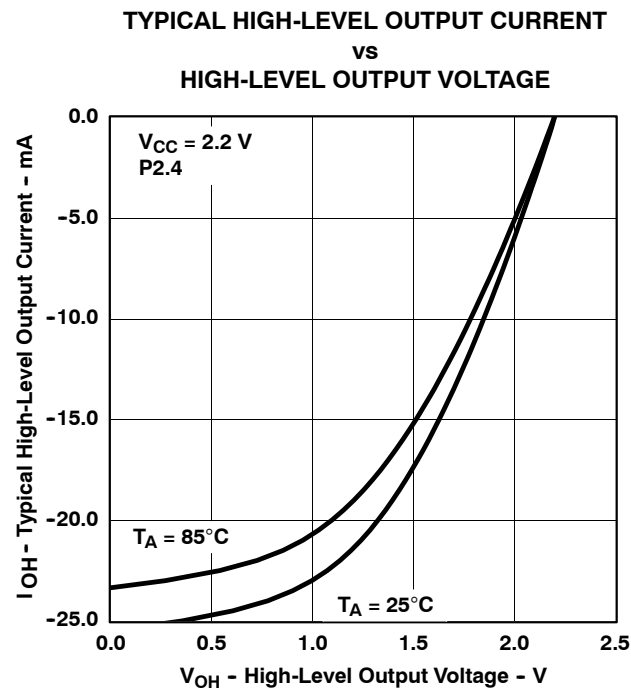

Figure 6

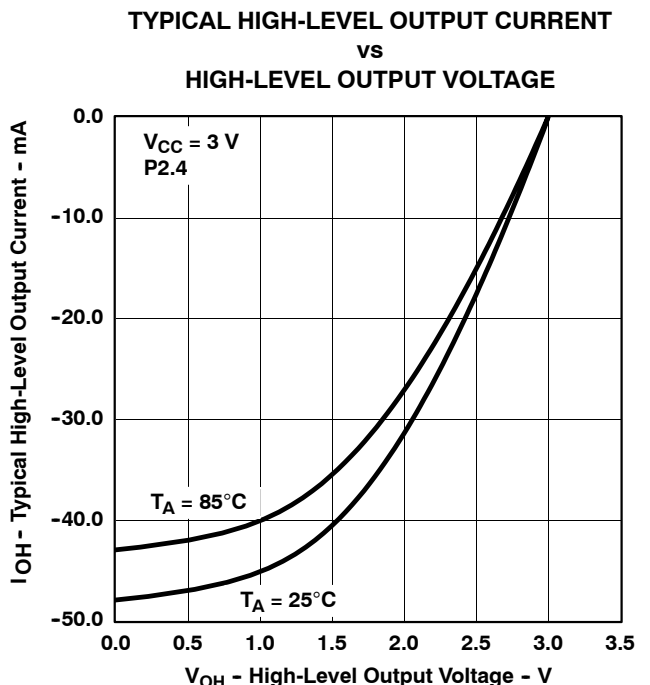

Figure 7

NOTE : One output loaded at a time.

MSP430F23x0 MIXED SIGNAL MICROCONTROLLER

SLAS518A - AUGUST 2006 - REVISED MAY 2007

electrical characteristics over recommended ranges of supply voltage and operating free-air temperature (unless otherwise noted) (continued)

POR/brownout reset (BOR) (see Notes 1 and 2)

PARAMETER		TEST CONDITIONS	VCC	MIN	TYP	MAX	UNIT
$V_{CC(start)}$	(see Figure 8)	$dV_{CC}/dt \leq 3 \text{ V/s}$		$0.7 \times V_{(B_IT-)}$			V
$V_{(B_IT-)}$	(see Figure 8 through Figure 10)	$dV_{CC}/dt \leq 3 \text{ V/s}$				1.71	V
$V_{hys(B_IT-)}$	(see Figure 8)	$dV_{CC}/dt \leq 3 \text{ V/s}$		70	130	210	mV
$t_{d(BOR)}$	(see Figure 8)					2000	μs
$t_{(reset)}$	Pulse length needed at $\overline{\text{RST}}/\text{NMI}$ pin to accepted reset internally		2.2 V/3 V	2			μs

- NOTES: 1. The current consumption of the brownout module is already included in the I_{CC} current consumption data. The voltage level $V_{(B_IT-)} + V_{hys(B_IT-)}$ is $\leq 1.8\text{V}$.
2. During power up, the CPU begins code execution following a period of $t_{d(BOR)}$ after $V_{CC} = V_{(B_IT-)} + V_{hys(B_IT-)}$. The default DCO settings must not be changed until $V_{CC} \geq V_{CC(min)}$, where $V_{CC(min)}$ is the minimum supply voltage for the desired operating frequency.

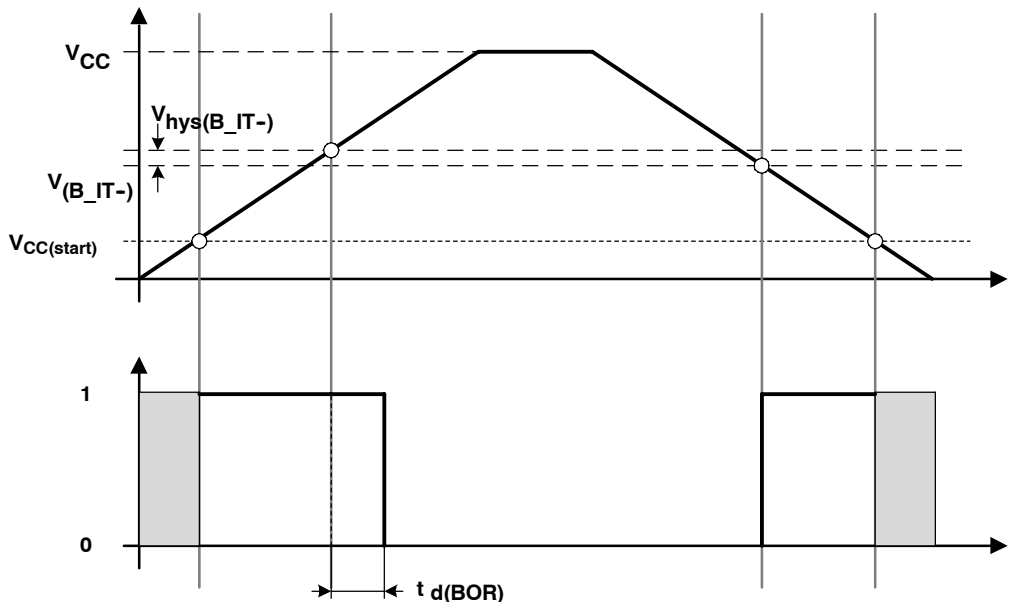

Figure 8. POR/Brownout Reset (BOR) vs Supply Voltage

electrical characteristics over recommended ranges of supply voltage and operating free-air temperature (unless otherwise noted) (continued)

typical characteristics - POR/brownout reset (BOR)

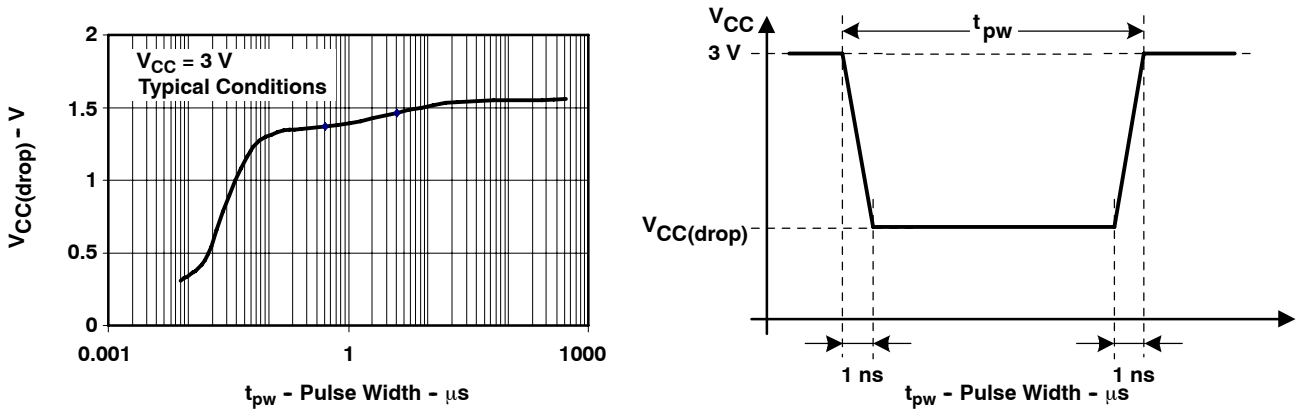

Figure 9. $V_{CC(drop)}$ Level With a Square Voltage Drop to Generate a POR/Brownout Signal

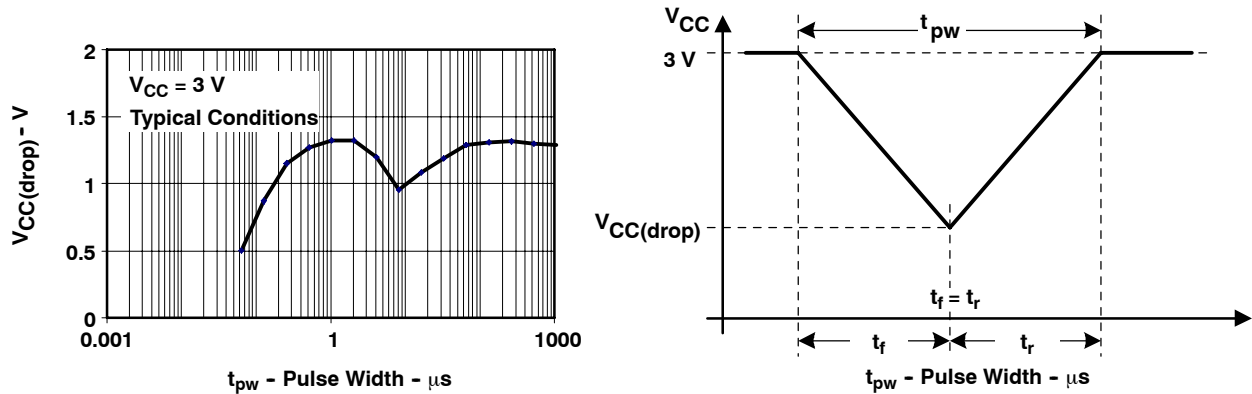

Figure 10. $V_{CC(drop)}$ Level With a Triangle Voltage Drop to Generate a POR/Brownout Signal

MSP430F23x0 MIXED SIGNAL MICROCONTROLLER

SLAS518A - AUGUST 2006 - REVISED MAY 2007

electrical characteristics over recommended ranges of supply voltage and operating free-air temperature (unless otherwise noted) (continued)

main DCO characteristics

- All ranges selected by RSELx overlap with RSELx + 1: RSELx = 0 overlaps RSELx = 1, ... RSELx = 14 overlaps RSELx = 15.
- DCO control bits DCOx have a step size as defined by parameter S_{DCO}.
- Modulation control bits MODx select how often f_{DCO(RSEL,DCO+1)} is used within the period of 32 DCOCLK cycles. The frequency f_{DCO(RSEL,DCO)} is used for the remaining cycles. The frequency is an average equal to:

$$f_{average} = \frac{32 \times f_{DCO(RSEL,DCO)} \times f_{DCO(RSEL,DCO+1)}}{MOD \times f_{DCO(RSEL,DCO)} + (32 - MOD) \times f_{DCO(RSEL,DCO+1)}}$$

DCO frequency

PARAMETER	TEST CONDITIONS	VCC	MIN	TYP	MAX	UNIT	
V _{CC} Supply voltage range	RSELx < 14		1.8		3.6	V	
	RSELx = 14		2.2		3.6	V	
	RSELx = 15		3.0		3.6	V	
f _{DCO(0,0)}	DCO frequency (0, 0)	RSELx = 0, DCOx = 0, MODx = 0	2.2 V/3 V	0.06	0.14	MHz	
f _{DCO(0,3)}	DCO frequency (0, 3)	RSELx = 0, DCOx = 3, MODx = 0	2.2 V/3 V	0.07	0.17	MHz	
f _{DCO(1,3)}	DCO frequency (1, 3)	RSELx = 1, DCOx = 3, MODx = 0	2.2 V/3 V	0.10	0.20	MHz	
f _{DCO(2,3)}	DCO frequency (2, 3)	RSELx = 2, DCOx = 3, MODx = 0	2.2 V/3 V	0.14	0.28	MHz	
f _{DCO(3,3)}	DCO frequency (3, 3)	RSELx = 3, DCOx = 3, MODx = 0	2.2 V/3 V	0.20	0.40	MHz	
f _{DCO(4,3)}	DCO frequency (4, 3)	RSELx = 4, DCOx = 3, MODx = 0	2.2 V/3 V	0.28	0.54	MHz	
f _{DCO(5,3)}	DCO frequency (5, 3)	RSELx = 5, DCOx = 3, MODx = 0	2.2 V/3 V	0.39	0.77	MHz	
f _{DCO(6,3)}	DCO frequency (6, 3)	RSELx = 6, DCOx = 3, MODx = 0	2.2 V/3 V	0.54	1.06	MHz	
f _{DCO(7,3)}	DCO frequency (7, 3)	RSELx = 7, DCOx = 3, MODx = 0	2.2 V/3 V	0.80	1.50	MHz	
f _{DCO(8,3)}	DCO frequency (8, 3)	RSELx = 8, DCOx = 3, MODx = 0	2.2 V/3 V	1.10	2.10	MHz	
f _{DCO(9,3)}	DCO frequency (9, 3)	RSELx = 9, DCOx = 3, MODx = 0	2.2 V/3 V	1.60	3.00	MHz	
f _{DCO(10,3)}	DCO frequency (10, 3)	RSELx = 10, DCOx = 3, MODx = 0	2.2 V/3 V	2.50	4.30	MHz	
f _{DCO(11,3)}	DCO frequency (11, 3)	RSELx = 11, DCOx = 3, MODx = 0	2.2 V/3 V	3.00	5.50	MHz	
f _{DCO(12,3)}	DCO frequency (12, 3)	RSELx = 12, DCOx = 3, MODx = 0	2.2 V/3 V	4.30	7.30	MHz	
f _{DCO(13,3)}	DCO frequency (13, 3)	RSELx = 13, DCOx = 3, MODx = 0	2.2 V/3 V	6.00	9.60	MHz	
f _{DCO(14,3)}	DCO frequency (14, 3)	RSELx = 14, DCOx = 3, MODx = 0	2.2 V/3 V	8.60	13.9	MHz	
f _{DCO(15,3)}	DCO frequency (15, 3)	RSELx = 15, DCOx = 3, MODx = 0	3 V	12.0	18.5	MHz	
f _{DCO(15,7)}	DCO frequency (15, 7)	RSELx = 15, DCOx = 7, MODx = 0	3 V	16.0	26.0	MHz	
S _{RSEL}	Frequency step between range RSEL and RSEL+1	S _{RSEL} = f _{DCO(RSEL+1,DCO)} /f _{DCO(RSEL,DCO)}	2.2 V/3 V		1.55	ratio	
S _{DCO}	Frequency step between tap DCO and DCO+1	S _{DCO} = f _{DCO(RSEL,DCO+1)} /f _{DCO(RSEL,DCO)}	2.2 V/3 V	1.05	1.08		1.12
Duty Cycle		Measured at P1.4/SMCLK	2.2 V/3 V	40	50	60	%



electrical characteristics over recommended ranges of supply voltage and operating free-air temperature (unless otherwise noted) (continued)

calibrated DCO frequencies - tolerance at calibration

PARAMETER	TEST CONDITIONS	T _A	VCC	MIN	TYP	MAX	UNIT
Frequency tolerance at calibration		25°C	3 V	-1	±0.2	+1	%
f _{CAL(1MHz)} 1MHz calibration value	BCSCTL1= CALBC1_1MHZ; DCOCTL = CALDCO_1MHZ Gating time: 5ms	25°C	3 V	0.990	1	1.010	MHz
f _{CAL(8MHz)} 8MHz calibration value	BCSCTL1= CALBC1_8MHZ; DCOCTL = CALDCO_8MHZ Gating time: 5ms	25°C	3 V	7.920	8	8.080	MHz
f _{CAL(12MHz)} 12MHz calibration value	BCSCTL1= CALBC1_12MHZ; DCOCTL = CALDCO_12MHZ Gating time: 5ms	25°C	3 V	11.88	12	12.12	MHz
f _{CAL(16MHz)} 16MHz calibration value	BCSCTL1= CALBC1_16MHZ; DCOCTL = CALDCO_16MHZ Gating time: 2ms	25°C	3 V	15.84	16	16.16	MHz

calibrated DCO frequencies - tolerance over temperature 0°C - +85°C

PARAMETER	TEST CONDITIONS	T _A	VCC	MIN	TYP	MAX	UNIT
1 MHz tolerance over temperature		0°C - 85°C	3.0 V	-2.5	±0.5	+2.5	%
8 MHz tolerance over temperature		0°C - 85°C	3.0 V	-2.5	±1	+2.5	%
12 MHz tolerance over temperature		0°C - 85°C	3.0 V	-2.5	±1	+2.5	%
16 MHz tolerance over temperature		0°C - 85°C	3.0 V	-3	±2	+3	%
f _{CAL(1MHz)} 1MHz calibration value	BCSCTL1= CALBC1_1MHZ; DCOCTL = CALDCO_1MHZ Gating time: 5ms	0°C - 85°C	2.2 V	0.970	1	1.030	MHz
			3.0 V	0.975	1	1.025	MHz
			3.6 V	0.970	1	1.030	MHz
f _{CAL(8MHz)} 8MHz calibration value	BCSCTL1= CALBC1_8MHZ; DCOCTL = CALDCO_8MHZ Gating time: 5ms	0°C - 85°C	2.2 V	7.760	8	8.400	MHz
			3.0 V	7.800	8	8.200	MHz
			3.6 V	7.600	8	8.240	MHz
f _{CAL(12MHz)} 12MHz calibration value	BCSCTL1= CALBC1_12MHZ; DCOCTL = CALDCO_12MHZ Gating time: 5ms	0°C - 85°C	2.2 V	11.64	12	12.36	MHz
			3.0 V	11.64	12	12.36	MHz
			3.6 V	11.64	12	12.36	MHz
f _{CAL(16MHz)} 16MHz calibration value	BCSCTL1= CALBC1_16MHZ; DCOCTL = CALDCO_16MHZ Gating time: 2ms	0°C - 85°C	3.0 V	15.52	16	16.48	MHz
			3.6 V	15.00	16	16.48	MHz

MSP430F23x0 MIXED SIGNAL MICROCONTROLLER

SLAS518A - AUGUST 2006 - REVISED MAY 2007

electrical characteristics over recommended ranges of supply voltage and operating free-air temperature (unless otherwise noted) (continued)

calibrated DCO frequencies - tolerance over supply voltage V_{CC}

PARAMETER	TEST CONDITIONS	T_A	V_{CC}	MIN	TYP	MAX	UNIT
1 MHz tolerance over V_{CC}		25°C	1.8 V - 3.6 V	-3	±2	+3	%
8 MHz tolerance over V_{CC}		25°C	1.8 V - 3.6 V	-3	±2	+3	%
12 MHz tolerance over V_{CC}		25°C	2.2 V - 3.6 V	-3	±2	+3	%
16 MHz tolerance over V_{CC}		25°C	3.0 V - 3.6 V	-6	±2	+3	%
$f_{CAL(1MHz)}$ 1MHz calibration value	BCSCTL1 = CALBC1_1MHZ; DCOCTL = CALDCO_1MHZ Gating time: 5ms	25°C	1.8 V - 3.6 V	0.970	1	1.030	MHz
$f_{CAL(8MHz)}$ 8MHz calibration value	BCSCTL1 = CALBC1_8MHZ; DCOCTL = CALDCO_8MHZ Gating time: 5ms	25°C	1.8 V - 3.6 V	7.760	8	8.240	MHz
$f_{CAL(12MHz)}$ 12MHz calibration value	BCSCTL1 = CALBC1_12MHZ; DCOCTL = CALDCO_12MHZ Gating time: 5ms	25°C	2.2 V - 3.6 V	11.64	12	12.36	MHz
$f_{CAL(16MHz)}$ 16MHz calibration value	BCSCTL1 = CALBC1_16MHZ; DCOCTL = CALDCO_16MHZ Gating time: 2ms	25°C	3.0 V - 3.6 V	15.00	16	16.48	MHz

calibrated DCO frequencies - overall tolerance

PARAMETER	TEST CONDITIONS	T_A	V_{CC}	MIN	TYP	MAX	UNIT
1 MHz tolerance overall		-40°C - 105°C	1.8 V - 3.6 V	-5	±2	+5	%
8 MHz tolerance overall		-40°C - 105°C	1.8 V - 3.6 V	-5	±2	+5	%
12 MHz tolerance overall		-40°C - 105°C	2.2 V - 3.6 V	-5	±2	+5	%
16 MHz tolerance overall		-40°C - 105°C	3.0 V - 3.6 V	-6	±3	+6	%
$f_{CAL(1MHz)}$ 1MHz calibration value	BCSCTL1 = CALBC1_1MHZ; DCOCTL = CALDCO_1MHZ Gating time: 5ms	-40°C - 105°C	1.8 V - 3.6 V	0.950	1	1.050	MHz
$f_{CAL(8MHz)}$ 8MHz calibration value	BCSCTL1 = CALBC1_8MHZ; DCOCTL = CALDCO_8MHZ Gating time: 5ms	-40°C - 105°C	1.8 V - 3.6 V	7.600	8	8.400	MHz
$f_{CAL(12MHz)}$ 12MHz calibration value	BCSCTL1 = CALBC1_12MHZ; DCOCTL = CALDCO_12MHZ Gating time: 5ms	-40°C - 105°C	2.2 V - 3.6 V	11.40	12	12.60	MHz
$f_{CAL(16MHz)}$ 16MHz calibration value	BCSCTL1 = CALBC1_16MHZ; DCOCTL = CALDCO_16MHZ Gating time: 2ms	-40°C - 105°C	3.0 V - 3.6 V	15.00	16	17.00	MHz



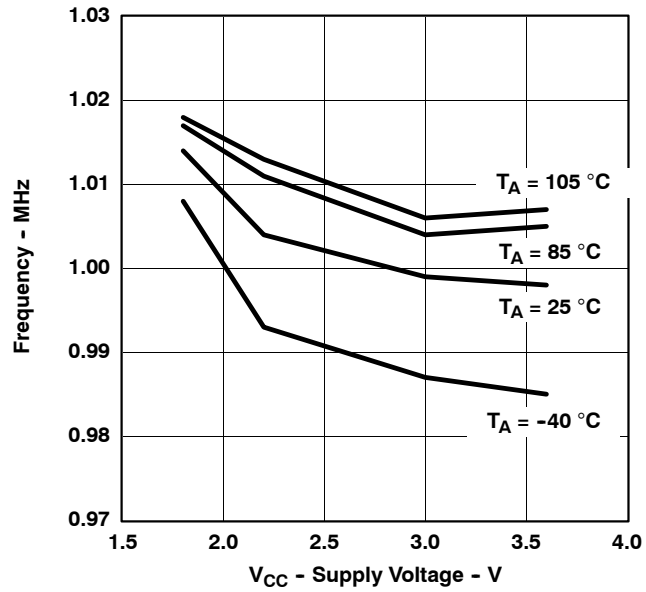

Figure 11. Calibrated 1 MHz Frequency vs. V_{CC}

MSP430F23x0 MIXED SIGNAL MICROCONTROLLER

SLAS518A - AUGUST 2006 - REVISED MAY 2007

electrical characteristics over recommended ranges of supply voltage and operating free-air temperature (unless otherwise noted) (continued)

wake-up from lower power modes (LPM3/4)

PARAMETER	TEST CONDITIONS	VCC	MIN	TYP	MAX	UNIT
$t_{DCO,LPM3/4}$ DCO clock wake-up time from LPM3/4 (see Note 1)	BCSCTL1= CALBC1_1MHZ; DCOCTL = CALDCO_1MHZ	2.2 V/3 V			2	μ S
	BCSCTL1= CALBC1_8MHZ; DCOCTL = CALDCO_8MHZ	2.2 V/3 V			1.5	
	BCSCTL1= CALBC1_12MHZ; DCOCTL = CALDCO_12MHZ	2.2 V/3 V			1	
	BCSCTL1= CALBC1_16MHZ; DCOCTL = CALDCO_16MHZ	3 V			1	
$t_{CPU,LPM3/4}$ CPU wake-up time from LPM3/4 (see Note 2)				$1/f_{MCLK} +$ $t_{Clock,LPM3/4}$		

NOTES: 1. The DCO clock wake-up time is measured from the edge of an external wake-up signal (e.g. port interrupt) to the first clock edge observable externally on a clock pin (MCLK or SMCLK).
2. Parameter applicable only if DCOCLK is used for MCLK.

typical characteristics - DCO clock wake-up time from LPM3/4

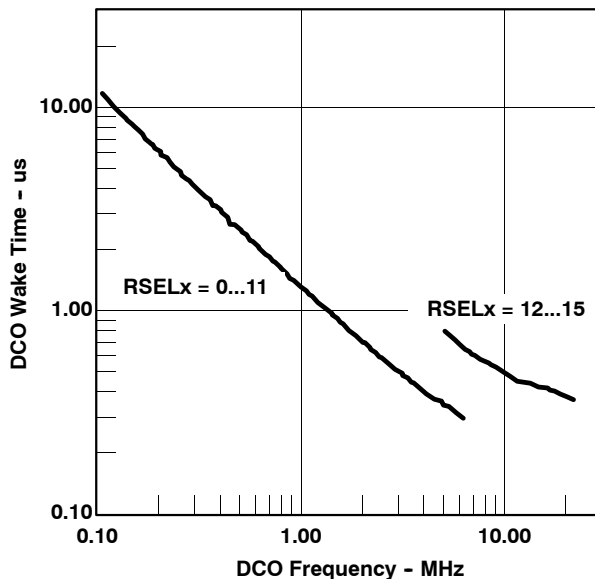

Figure 12. Clock wake-up time from LPM3 vs DCO frequency

electrical characteristics over recommended ranges of supply voltage and operating free-air temperature (unless otherwise noted) (continued)

DCO with external resistor R_{OSC} (see Note)

PARAMETER	TEST CONDITIONS	VCC	MIN	TYP	MAX	UNIT
$f_{DCO,ROSC}$ DCO output frequency with R_{OSC}	DCOR = 1, RSELx = 4, DCOx = 3, MODx = 0, $T_A = 25^\circ\text{C}$	2.2 V		1.8		MHz
		3 V		1.95		
D_t Temperature drift	DCOR = 1, RSELx = 4, DCOx = 3, MODx = 0	2.2 V/3 V		± 0.1		$\%/\text{C}$
D_V Drift with V_{CC}	DCOR = 1, RSELx = 4, DCOx = 3, MODx = 0	2.2 V/3 V		10		$\%/V$

NOTE : $R_{OSC} = 100\text{k}\Omega$. Metal film resistor, type 0257. 0.6 watt with 1% tolerance and $T_K = \pm 50\text{ppm}/\text{C}$.

typical characteristics - DCO with external resistor R_{OSC}

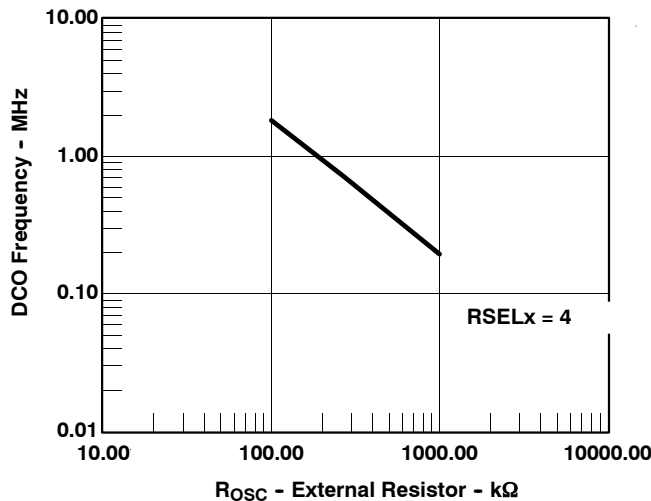

Figure 13. DCO Frequency vs R_{OSC} , $V_{CC} = 2.2\text{ V}$, $T_A = 25^\circ\text{C}$

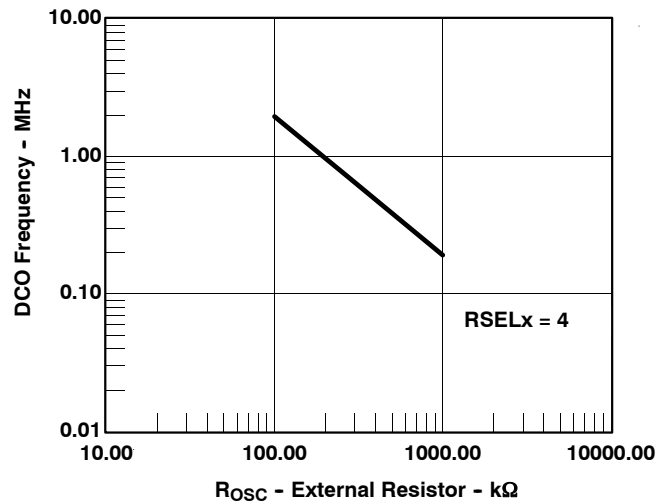

Figure 14. DCO Frequency vs R_{OSC} , $V_{CC} = 3.0\text{ V}$, $T_A = 25^\circ\text{C}$

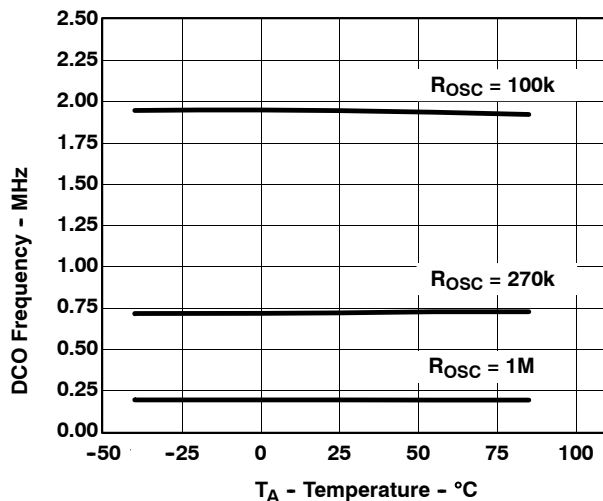

Figure 15. DCO Frequency vs Temperature, $V_{CC} = 3.0\text{ V}$

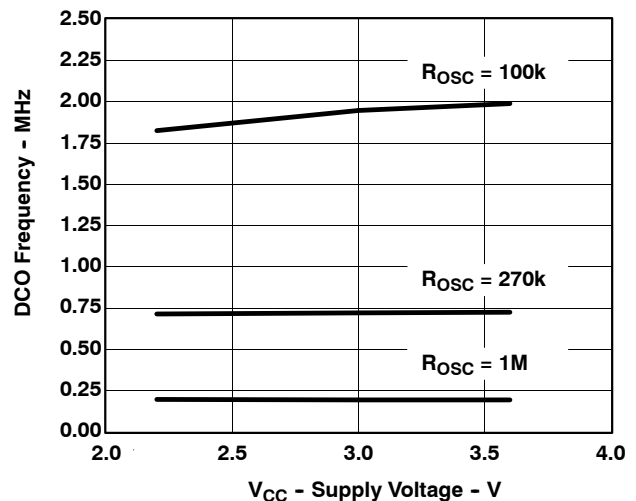

Figure 16. DCO Frequency vs V_{CC} , $T_A = 25^\circ\text{C}$

MSP430F23x0 MIXED SIGNAL MICROCONTROLLER

SLAS518A - AUGUST 2006 - REVISED MAY 2007

electrical characteristics over recommended ranges of supply voltage and operating free-air temperature (unless otherwise noted) (continued)

crystal oscillator, LFXT1, low frequency modes (see Note 4)

PARAMETER		TEST CONDITIONS	VCC	MIN	TYP	MAX	UNIT
$f_{LFXT1,LF}$	LFXT1 oscillator crystal frequency, LF mode 0, 1	XTS = 0, LFXT1Sx = 0 or 1	1.8 V - 3.6 V		32,768		Hz
$f_{LFXT1,LF,logic}$	LFXT1 oscillator logic level square wave input frequency, LF mode	XTS = 0, XCAPx = 0, LFXT1Sx = 3	1.8 V - 3.6 V	10,000	32,768	50,000	Hz
OALF	Oscillation allowance for LF crystals	XTS = 0, LFXT1Sx = 0; $f_{LFXT1,LF} = 32,768$ kHz, $C_{L,eff} = 6$ pF			500		k Ω
		XTS = 0, LFXT1Sx = 0; $f_{LFXT1,LF} = 32,768$ kHz, $C_{L,eff} = 12$ pF			200		k Ω
C _{L,eff}	Integrated effective load capacitance, LF mode (see Note 1)	XTS = 0, XCAPx = 0			1		pF
		XTS = 0, XCAPx = 1			5.5		pF
		XTS = 0, XCAPx = 2			8.5		pF
		XTS = 0, XCAPx = 3			11		pF
Duty cycle	LF mode	XTS = 0, Measured at P1.4/ACLK, $f_{LFXT1,LF} = 32,768$ Hz	2.2 V/3 V	30	50	70	%
$f_{Fault,LF}$	Oscillator fault frequency, LF mode (see Note 3)	XTS = 0, XCAPx = 0. LFXT1Sx = 3 (see Note 2)	2.2 V/3 V	10		10,000	Hz

- NOTES: 1. Includes parasitic bond and package capacitance (approximately 2 pF per pin).
Since the PCB adds additional capacitance it is recommended to verify the correct load by measuring the ACLK frequency. For a correct setup the effective load capacitance should always match the specification of the used crystal.
2. Measured with logic level input frequency but also applies to operation with crystals.
3. Frequencies below the MIN specification will set the fault flag, frequencies above the MAX specification will not set the fault flag. Frequencies in between might set the flag.
4. To improve EMI on the LFXT1 oscillator the following guidelines should be observed.
- Keep as short of a trace as possible between the device and the crystal.
 - Design a good ground plane around the oscillator pins.
 - Prevent crosstalk from other clock or data lines into oscillator pins XIN and XOUT.
 - Avoid running PCB traces underneath or adjacent to the XIN and XOUT pins.
 - Use assembly materials and praxis to avoid any parasitic load on the oscillator XIN and XOUT pins.
 - If conformal coating is used, ensure that it does not induce capacitive/resistive leakage between the oscillator pins.
 - Do not route the XOUT line to the JTAG header to support the serial programming adapter as shown in other documentation. This signal is no longer required for the serial programming adapter.

internal very low power, low frequency oscillator (VLO)

PARAMETER		TEST CONDITIONS	VCC	MIN	TYP	MAX	UNIT
f_{VLO}	VLO frequency		2.2 V/3 V	4	12	20	kHz
df_{VLO}/dT	VLO frequency temperature drift	(See Note 1)	2.2 V/3 V		0.5		%/°C
df_{VLO}/dV_{CC}	VLO frequency supply voltage drift	(See Note 2)	1.8V - 3.6V		4		%/V

- NOTES: 1. Calculated using the box method:
I Version: $(MAX(-40...85^{\circ}C) - MIN(-40...85^{\circ}C))/MIN(-40...85^{\circ}C)/(85^{\circ}C - (-40^{\circ}C))$
T Version: $(MAX(-40...105_C) - MIN(-40...105_C))/MIN(-40...105_C)/(105_C - (-40_C))$
2. Calculated using the box method: $(MAX(1.8...3.6V) - MIN(1.8...3.6V))/MIN(1.8...3.6V)/(3.6V - 1.8V)$



electrical characteristics over recommended ranges of supply voltage and operating free-air temperature (unless otherwise noted) (continued)

crystal oscillator, LFXT1, high frequency modes (see Note 5)

PARAMETER		TEST CONDITIONS	VCC	MIN	TYP	MAX	UNIT
$f_{LFXT1,HF0}$	LFXT1 oscillator crystal frequency, HF mode 0	XTS = 1, XCAPx = 0, LFXT1Sx = 0	1.8 V - 3.6 V	0.4		1	MHz
$f_{LFXT1,HF1}$	LFXT1 oscillator crystal frequency, HF mode 1	XTS = 1, XCAPx = 0, LFXT1Sx = 1	1.8 V - 3.6 V	1		4	MHz
$f_{LFXT1,HF2}$	LFXT1 oscillator crystal frequency, HF mode 2	XTS = 1, XCAPx = 0, LFXT1Sx = 2	1.8 V - 3.6 V	2		10	MHz
			2.2 V - 3.6 V	2		12	MHz
			3.0 V - 3.6 V	2		16	MHz
$f_{LFXT1,HF,logic}$	LFXT1 oscillator logic level square wave input frequency, HF mode	XTS = 1, XCAPx = 0, LFXT1Sx = 3	1.8 V - 3.6 V	0.4		10	MHz
			2.2 V - 3.6 V	0.4		12	MHz
			3.0 V - 3.6 V	0.4		16	MHz
OA _{HF}	Oscillation allowance for HF crystals (refer to Figure 17 and Figure 18)	XTS = 1, XCAPx = 0, LFXT1Sx = 0, $f_{LFXT1,HF} = 1$ MHz, $C_{L,eff} = 15$ pF			2700		Ω
		XTS = 1, XCAPx = 0, LFXT1Sx = 1, $f_{LFXT1,HF} = 4$ MHz, $C_{L,eff} = 15$ pF			800		Ω
		XTS = 1, XCAPx = 0, LFXT1Sx = 2, $f_{LFXT1,HF} = 16$ MHz, $C_{L,eff} = 15$ pF			300		Ω
$C_{L,eff}$	Integrated effective load capacitance, HF mode (see Note 1)	XTS = 1, XCAPx = 0 (see Note 2)			1		pF
Duty cycle	HF mode	XTS = 1, XCAPx = 0, Measured at P1.4/ACLK, $f_{LFXT1,HF} = 10$ MHz	2.2 V/3 V	40	50	60	%
		XTS = 1, XCAPx = 0, Measured at P1.4/ACLK, $f_{LFXT1,HF} = 16$ MHz	2.2 V/3 V	40	50	60	%
$f_{Fault,HF}$	Oscillator fault frequency, HF mode (see Note 4)	XTS = 1, XCAPx = 0, LFXT1Sx = 3 (see Notes 3)	2.2 V/3 V	30		300	kHz

- NOTES:
- Includes parasitic bond and package capacitance (approximately 2 pF per pin). Since the PCB adds additional capacitance it is recommended to verify the correct load by measuring the ACLK frequency. For a correct setup the effective load capacitance should always match the specification of the used crystal.
 - Requires external capacitors at both terminals. Values are specified by crystal manufacturers.
 - Measured with logic level input frequency but also applies to operation with crystals.
 - Frequencies below the MIN specification will set the fault flag, frequencies above the MAX specification will not set the fault flag. Frequencies in between might set the flag.
 - To improve EMI on the LFXT1 oscillator the following guidelines should be observed.
 - Keep as short of a trace as possible between the device and the crystal.
 - Design a good ground plane around the oscillator pins.
 - Prevent crosstalk from other clock or data lines into oscillator pins XIN and XOUT.
 - Avoid running PCB traces underneath or adjacent to the XIN and XOUT pins.
 - Use assembly materials and praxis to avoid any parasitic load on the oscillator XIN and XOUT pins.
 - If conformal coating is used, ensure that it does not induce capacitive/resistive leakage between the oscillator pins.
 - Do not route the XOUT line to the JTAG header to support the serial programming adapter as shown in other documentation. This signal is no longer required for the serial programming adapter.

MSP430F23x0 MIXED SIGNAL MICROCONTROLLER

SLAS518A - AUGUST 2006 - REVISED MAY 2007

electrical characteristics over recommended ranges of supply voltage and operating free-air temperature (unless otherwise noted) (continued)

typical characteristics - LFXT1 oscillator in HF mode (XTS = 1)

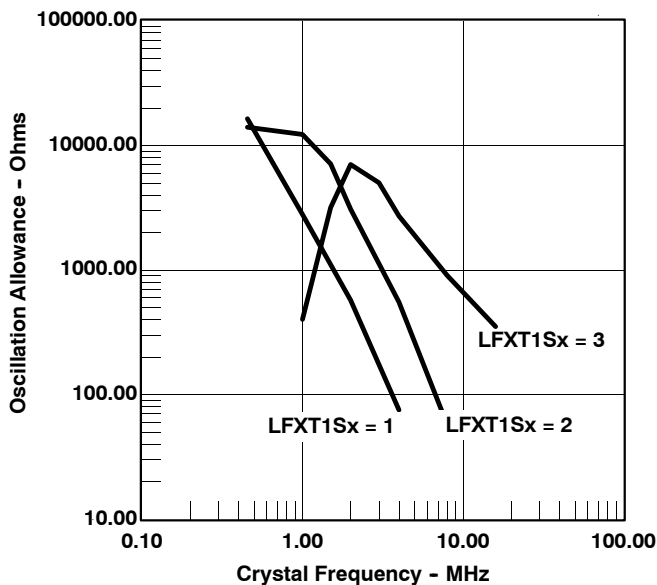

Figure 17. Oscillation Allowance vs Crystal Frequency, $C_{L,eff} = 15 \text{ pF}$, $T_A = 25^\circ\text{C}$

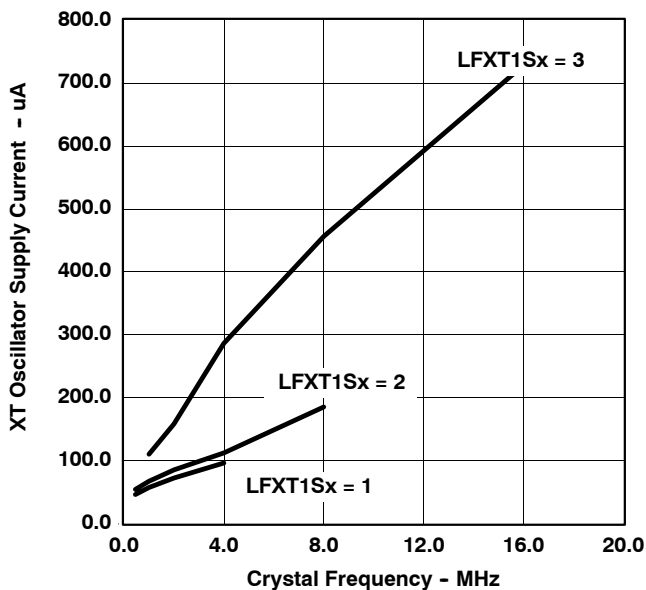

Figure 18. XT Oscillator Supply Current vs Crystal Frequency, $C_{L,eff} = 15 \text{ pF}$, $T_A = 25^\circ\text{C}$

electrical characteristics over recommended ranges of supply voltage and operating free-air temperature (unless otherwise noted) (continued)

Timer_A

PARAMETER		TEST CONDITIONS	VCC	MIN	TYP	MAX	UNIT
f _{TA}	Timer_A clock frequency	Internal: SMCLK, ACLK; External: TACLK, INCLK; Duty Cycle = 50% ±10%	2.2 V			10	MHz
			3 V			16	
t _{TA,cap}	Timer_A, capture timing	TA0, TA1, TA2	2.2 V/3 V	20			ns

Timer_B

PARAMETER		TEST CONDITIONS	VCC	MIN	TYP	MAX	UNIT
f _{TB}	Timer_B clock frequency	Internal: SMCLK, ACLK; External: TBCLK; Duty Cycle = 50% ±10%	2.2 V			10	MHz
			3 V			16	
t _{TB,cap}	Timer_B, capture timing	TB0, TB1, TB2	2.2 V/3 V	20			ns

MSP430F23x0 MIXED SIGNAL MICROCONTROLLER

SLAS518A - AUGUST 2006 - REVISED MAY 2007

electrical characteristics over recommended ranges of supply voltage and operating free-air temperature (unless otherwise noted) (continued)

USCI (UART Mode)

PARAMETER	TEST CONDITIONS	VCC	MIN	TYP	MAX	UNIT
f _{USCI}	USCI input clock frequency Internal: SMCLK, ACLK External: UCLK Duty Cycle = 50% ± 10%			f _{SYSTEM}		MHz
f _{BITCLK}	BITCLK clock frequency (equals baudrate in MBaud)	2.2V /3 V			1	MHz
t _τ	UART receive deglitch time (see Note NO TAG)	2.2 V	50	150	600	ns
		3 V	50	100	600	ns

NOTE : Pulses on the UART receive input (UCxRX) shorter than the UART receive deglitch time are suppressed. To ensure that pulses are correctly recognized their width should exceed the maximum specification of the deglitch time.

USCI (SPI Master Mode, see Figure 19 and Figure 20)

PARAMETER	TEST CONDITIONS	VCC	MIN	TYP	MAX	UNIT
f _{USCI}	USCI input clock frequency SMCLK, ACLK Duty Cycle = 50% ± 10%			f _{SYSTEM}		MHz
t _{SU,MI}	SOMI input data setup time	2.2 V	110			ns
		3 V	75			ns
t _{HD,MI}	SOMI input data hold time	2.2 V				ns
		3 V				ns
t _{VALID,MO}	SIMO output data valid time UCLK edge to SIMO valid; C _L = 20 pF	2.2 V			30	ns
		3 V			20	ns

USCI (SPI Slave Mode, see Figure 21 and Figure 22)

PARAMETER	TEST CONDITIONS	VCC	MIN	TYP	MAX	UNIT
t _{STE,LEAD}	STE lead time STE low to clock	2.2 V/3 V		50		ns
t _{STE,LAG}	STE lag time Last clock to STE high	2.2 V/3 V	10			ns
t _{STE,ACC}	STE access time STE low to SOMI data out	2.2 V/3 V		50		ns
t _{STE,DIS}	STE disable time STE high to SOMI high impedance	2.2 V/3 V		50		ns
t _{SU,SI}	SIMO input data setup time	2.2 V	20			ns
		3 V	15			ns
t _{HD,SI}	SIMO input data hold time	2.2 V	10			ns
		3 V	10			ns
t _{VALID,SO}	SOMI output data valid time UCLK edge to SOMI valid; C _L = 20 pF	2.2 V		75	110	ns
		3 V		50	75	ns



electrical characteristics over recommended ranges of supply voltage and operating free-air temperature (unless otherwise noted) (continued)6

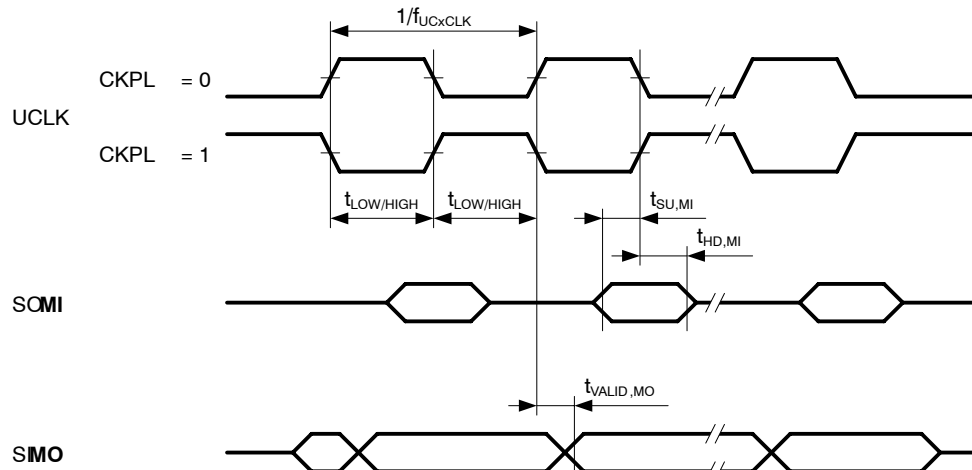

Figure 19. SPI Master Mode, CKPH = 0

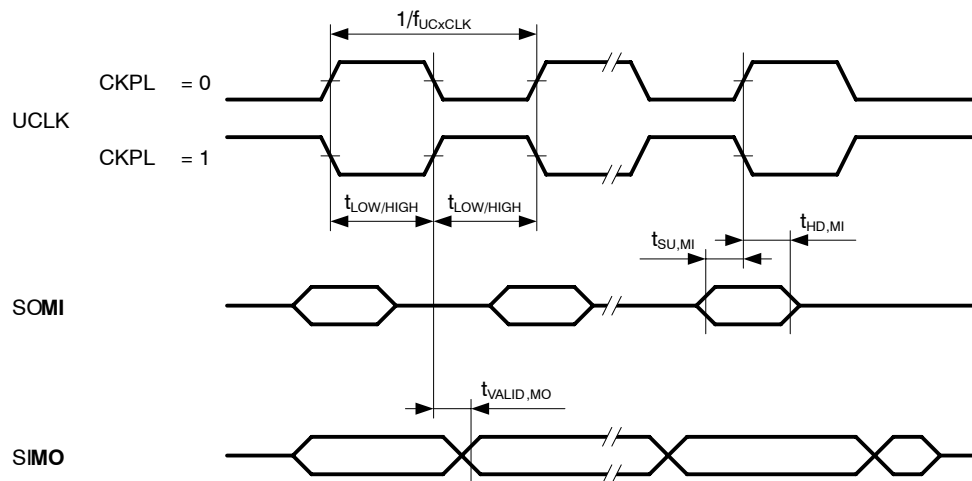

Figure 20. SPI Master Mode, CKPH = 1

MSP430F23x0 MIXED SIGNAL MICROCONTROLLER

SLAS518A - AUGUST 2006 - REVISED MAY 2007

electrical characteristics over recommended ranges of supply voltage and operating free-air temperature (unless otherwise noted) (continued)7

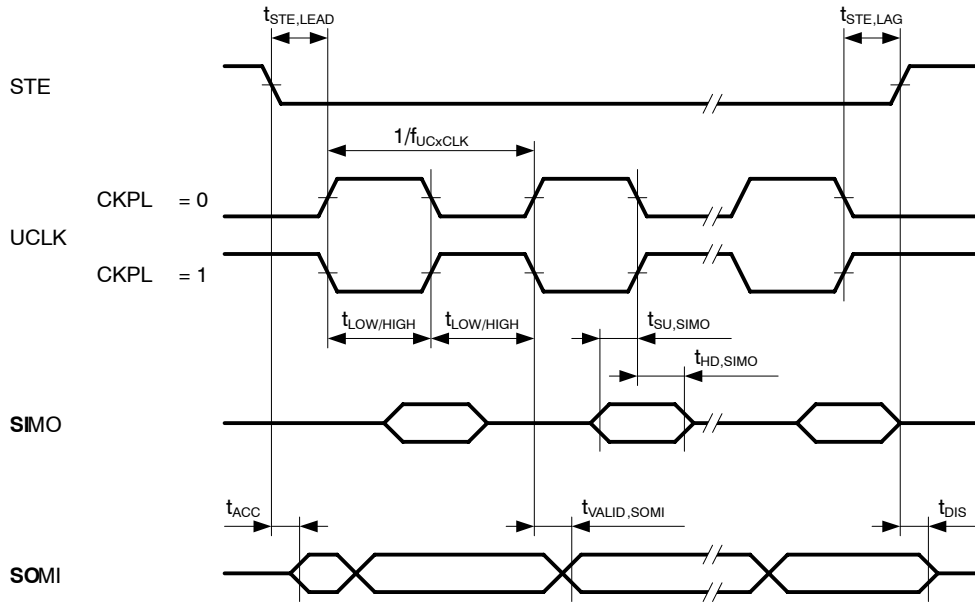

Figure 21. SPI Slave Mode, CKPH = 0

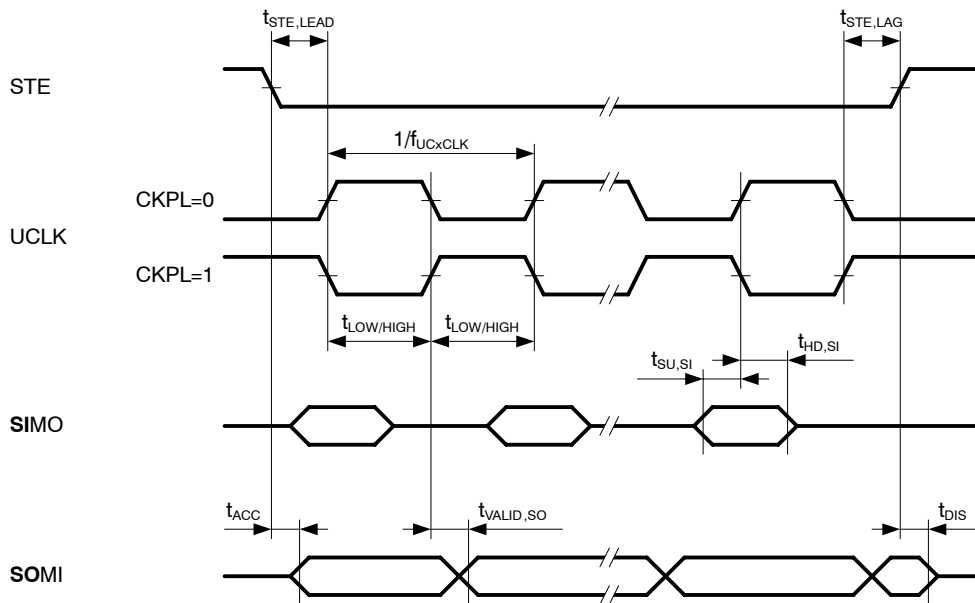

Figure 22. SPI Slave Mode, CKPH = 1

electrical characteristics over recommended ranges of supply voltage and operating free-air temperature (unless otherwise noted) (continued)

USCI (I2C Mode, see Figure 23)

PARAMETER	TEST CONDITIONS	VCC	MIN	TYP	MAX	UNIT
f_{USCI}	USCI input clock frequency	Internal: SMCLK, ACLK External: UCLK Duty Cycle = 50% ± 10%		f_{SYSTEM}		MHz
f_{SCL}	SCL clock frequency	2.2 V/3 V	0		400	kHz
$t_{HD,STA}$	Hold time (repeated) START	$f_{SCL} \leq 100\text{kHz}$	2.2 V/3 V	4.0		us
		$f_{SCL} > 100\text{kHz}$	2.2 V/3 V	0.6		us
$t_{SU,STA}$	Set-up time for a repeated START	$f_{SCL} \leq 100\text{kHz}$	2.2 V/3 V	4.7		us
		$f_{SCL} > 100\text{kHz}$	2.2 V/3 V	0.6		us
$t_{HD,DAT}$	Data hold time	2.2 V/3 V	0			ns
$t_{SU,DAT}$	Data setup time	2.2 V/3 V	250			ns
$t_{SU,STO}$	Setup time for STOP	2.2 V/3 V	4.0			us
t_{SP}	Pulse width of spikes suppressed by input filter	2.2 V	50	150	600	ns
		3 V	50	100	600	ns

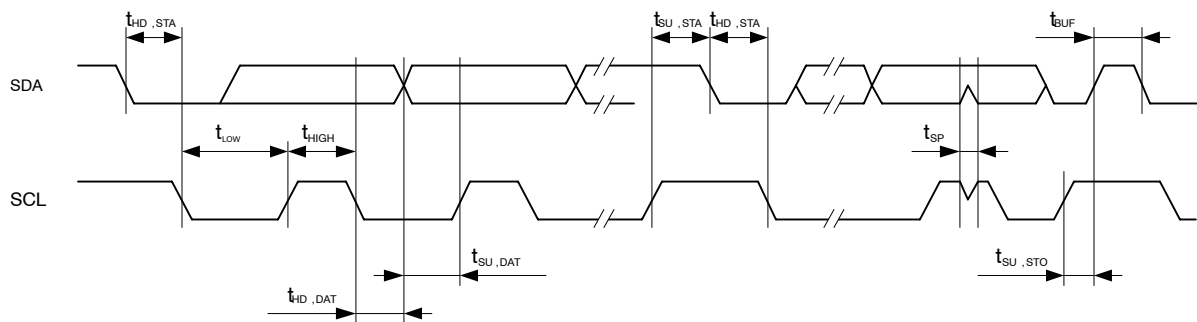

Figure 23. I2C Mode Timing

MSP430F23x0 MIXED SIGNAL MICROCONTROLLER

SLAS518A - AUGUST 2006 - REVISED MAY 2007

electrical characteristics over recommended ranges of supply voltage and operating free-air temperature (unless otherwise noted) (continued)

Comparator_A+ (see Note 1)

PARAMETER	TEST CONDITIONS	VCC	MIN	TYP	MAX	UNIT	
I _(DD)	CAON=1, CARSEL=0, CAREF=0	2.2 V	25	40		μA	
		3 V	45	60			
I _(Ref ladder/RefDiode)	CAON=1, CARSEL=0, CAREF=1/2/3, no load at P1.0/CA0 and P1.1/CA1	2.2 V	30	50		μA	
		3 V	45	71			
V _(IC)	Common-mode input voltage	CAON=1	2.2 V/3 V	0	V _{CC} -1	V	
V _(Ref025)	$\frac{\text{Voltage @ } 0.25 V_{CC} \text{ node}}{V_{CC}}$	PCA0=1, CARSEL=1, CAREF=1, no load at P1.0/CA0 and P1.1/CA1	2.2 V/3 V	0.23	0.24	0.25	
V _(Ref050)	$\frac{\text{Voltage @ } 0.5 V_{CC} \text{ node}}{V_{CC}}$	PCA0=1, CARSEL=1, CAREF=2, no load at P1.0/CA0 and P1.1/CA1	2.2 V/3 V	0.47	0.48	0.5	
V _(RefVT)	(see Figure 27 and Figure 28)	2.2 V	390	480	540	mV	
		3 V	400	490	550		
V _(offset)	Offset voltage	See Note 2	2.2 V/3 V	-30	30	mV	
V _(hys)	Input hysteresis	CAON=1	2.2 V/3 V	0	0.7	1.4	mV
t _(response)	Response time (low-high and high-low)	T _A = 25°C, Overdrive 10 mV, Without filter: CAF=0 (see Note 3, Figure 24 and Figure 25)	2.2 V	80	165	300	ns
			3 V	70	120	240	
		T _A = 25°C, Overdrive 10 mV, With filter: CAF=1 (see Note 3, Figure 24 and Figure 25)	2.2 V	1.4	1.9	2.8	μs
			3 V	0.9	1.5	2.2	

- NOTES: 1. The leakage current for the Comparator_A+ terminals is identical to I_{kg(Px.x)} specification.
 2. The input offset voltage can be cancelled by using the CAEX bit to invert the Comparator_A+ inputs on successive measurements. The two successive measurements are then summed together.
 3. Response time measured at P1.3/CAOUT.



electrical characteristics over recommended ranges of supply voltage and operating free-air temperature (unless otherwise noted) (continued)

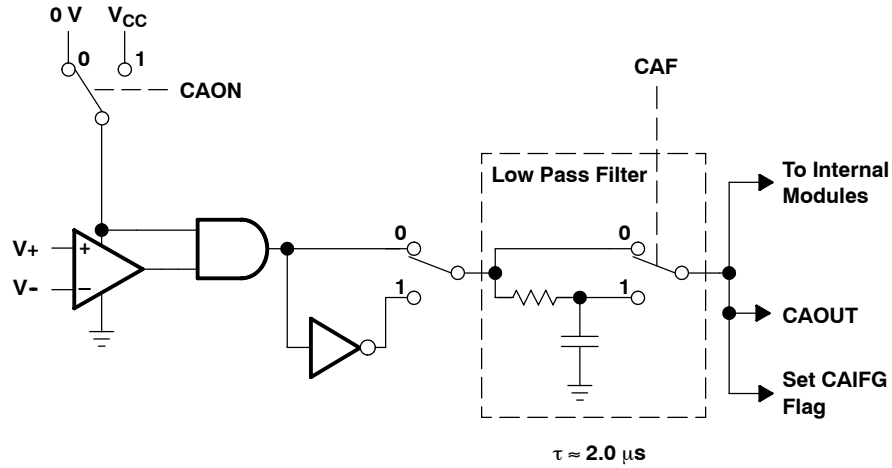

Figure 24. Block Diagram of Comparator_A+ Module

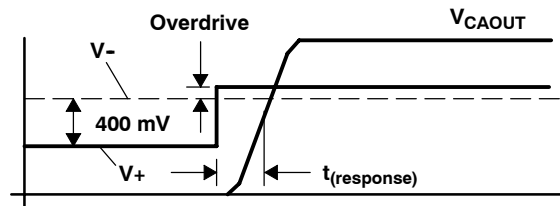

Figure 25. Overdrive Definition

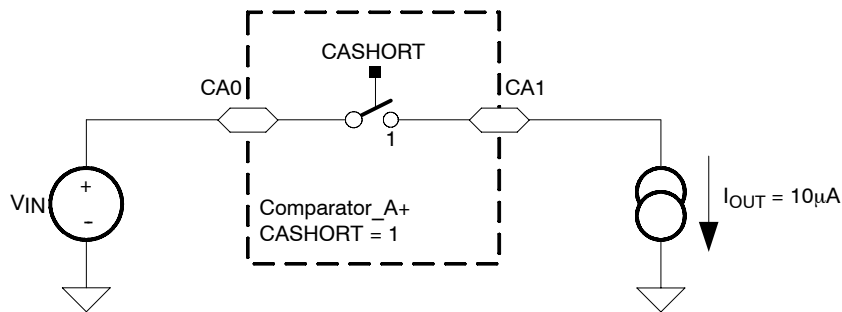

Figure 26. Comparator_A+ Short Resistance Test Condition

MSP430F23x0 MIXED SIGNAL MICROCONTROLLER

SLAS518A - AUGUST 2006 - REVISED MAY 2007

electrical characteristics over recommended ranges of supply voltage and operating free-air temperature (unless otherwise noted) (continued)

typical characteristics - Comparator_A+

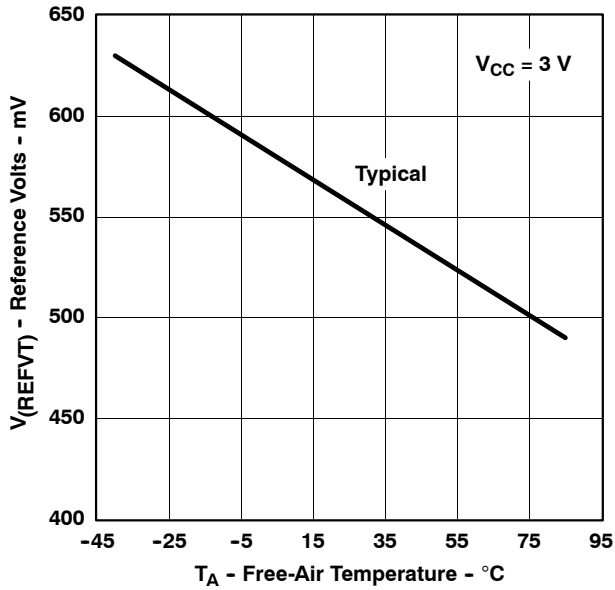

Figure 27. V_(REFVT) vs Temperature, V_{CC} = 3 V

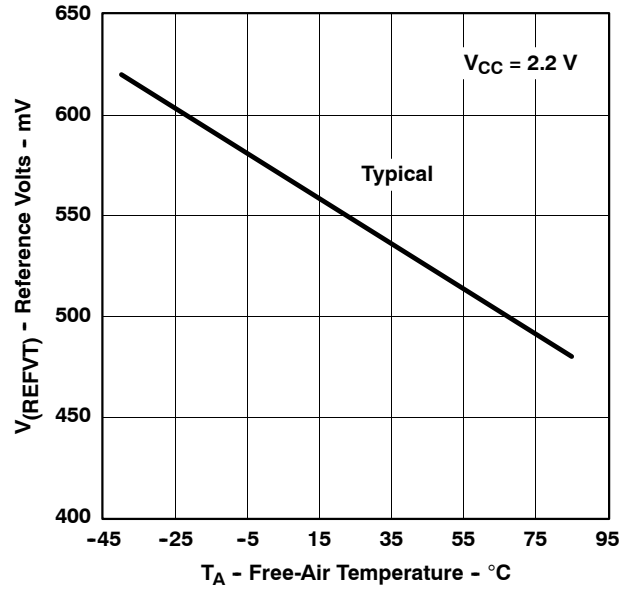

Figure 28. V_(REFVT) vs Temperature, V_{CC} = 2.2 V

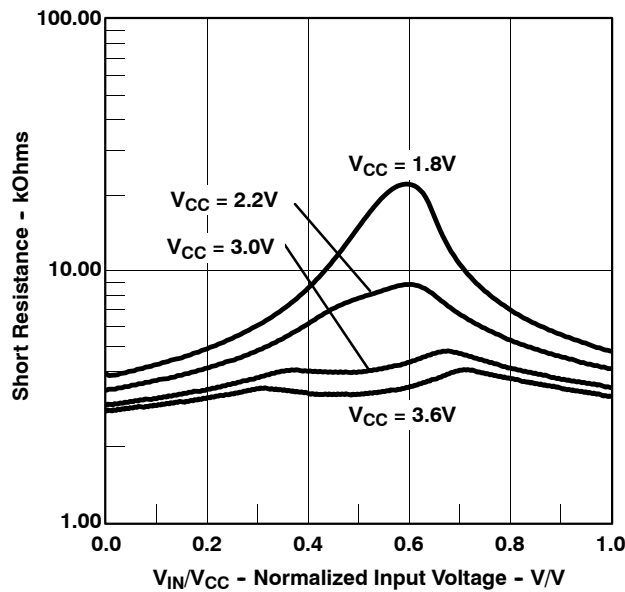

Figure 29. Short Resistance vs V_{IN}/V_{CC}

electrical characteristics over recommended ranges of supply voltage and operating free-air temperature (unless otherwise noted) (continued)

Flash Memory

PARAMETER		TEST CONDITIONS	VCC	MIN	TYP	MAX	UNIT
$V_{CC(PGM/ERASE)}$	Program and erase supply voltage			2.2		3.6	V
f_{FTG}	Flash Timing Generator frequency			257		476	kHz
I_{PGM}	Supply current from V_{CC} during program		2.2 V/3.6 V		1	5	mA
I_{ERASE}	Supply current from V_{CC} during erase		2.2 V/3.6 V		1	7	mA
t_{CPT}	Cumulative program time (see Note 1)		2.2 V/3.6 V			10	ms
$t_{CMErase}$	Cumulative mass erase time		2.2 V/3.6 V	20			ms
	Program/erase endurance			10^4	10^5		cycles
$t_{Retention}$	Data retention duration	$T_J = 25^\circ\text{C}$		100			years
t_{Word}	Word or byte program time	see Note 2			30		t_{FTG}
$t_{Block, 0}$	Block program time for first byte or word				25		
$t_{Block, 1-63}$	Block program time for each additional byte or word				18		
$t_{Block, End}$	Block program end-sequence wait time				6		
$t_{Mass Erase}$	Mass erase time				10593		
$t_{Seg Erase}$	Segment erase time				4819		

- NOTES: 1. The cumulative program time must not be exceeded when writing to a 64-byte flash block. This parameter applies to all programming methods: individual word/byte write and block write modes.
2. These values are hardwired into the Flash Controller's state machine ($t_{FTG} = 1/f_{FTG}$).

RAM

PARAMETER		TEST CONDITIONS	MIN	TYP	MAX	UNIT
$V_{(RAMh)}$	RAM retention supply voltage (see Note)	CPU halted	1.6			V

NOTE : This parameter defines the minimum supply voltage V_{CC} when the data in RAM remains unchanged. No program execution should happen during this supply voltage condition.

JTAG Interface

PARAMETER		TEST CONDITIONS	Vcc	MIN	NOM	MAX	UNIT
f_{TCK}	TCK input frequency	see Note 1	2.2 V	0		5	MHz
			3 V	0		10	MHz
$R_{Internal}$	Internal pullup resistance on TMS, TCK, TDI/TCLK	see Note 2	2.2 V/ 3 V	20	35	55	k Ω

- NOTES: 1. f_{TCK} may be restricted to meet the timing requirements of the module selected.
2. TMS, TDI/TCLK, and TCK pull-up resistors are implemented in all versions.

JTAG Fuse (see Note)

PARAMETER		TEST CONDITIONS	Vcc	MIN	NOM	MAX	UNIT
$V_{CC(FB)}$	Supply voltage during fuse-blow condition	$T_A = 25^\circ\text{C}$		2.5			V
V_{FB}	Voltage level on TDI/TCLK for fuse-blow: F versions			6		7	V
I_{FB}	Supply current into TDI/TCLK during fuse blow					100	mA
t_{FB}	Time to blow fuse					1	ms

NOTE : Once the fuse is blown, no further access to the MSP430 JTAG/Test and emulation features is possible. The JTAG block is switched to bypass mode.

MSP430F23x0 MIXED SIGNAL MICROCONTROLLER

SLAS518A - AUGUST 2006 - REVISED MAY 2007

APPLICATION INFORMATION

Port P1 pin schematic: P1.0 to P1.7, input/output with Schmitt-trigger

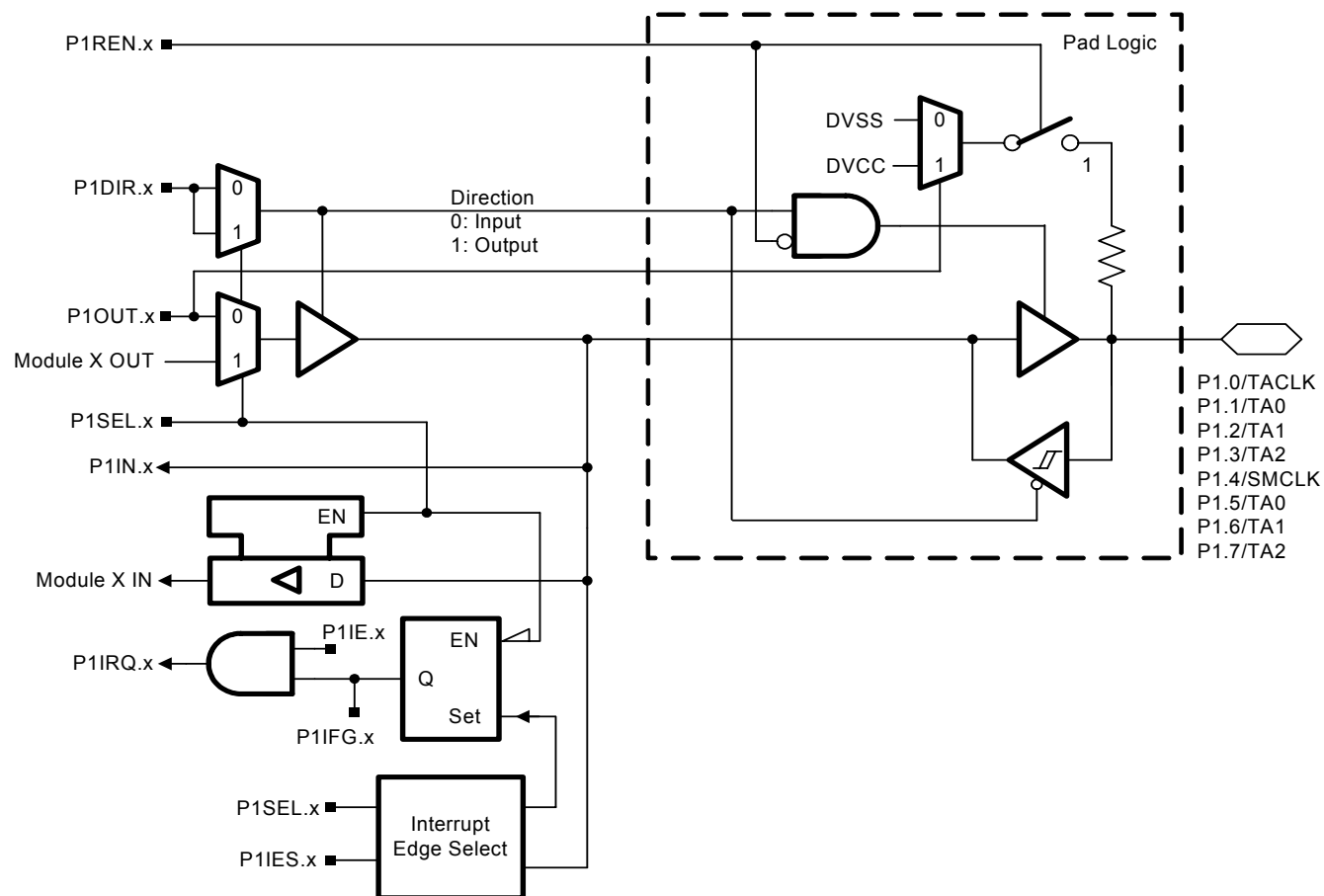

Port P1 (P1.0 to P1.7) pin functions

PIN NAME (P1.X)	X	FUNCTION	CONTROL BITS / SIGNALS	
			P1DIR.x	P1SEL.x
P1.0/TACLK	0	P1.0 (I/O)	I: 0; O: 1	0
		Timer_A3.TACLK	0	1
		DV _{SS}	1	1
P1.1/TA0	1	P1.1 (I/O)	I: 0; O: 1	0
		Timer_A3.CCI0A	0	1
		Timer_A3.TA0	1	1
P1.2/TA1	2	P1.2 (I/O)	I: 0; O: 1	0
		Timer_A3.CCI0A	0	1
		Timer_A3.TA0	1	1
P1.3/TA2	3	P1.3 (I/O)	I: 0; O: 1	0
		Timer_A3.CCI0A	0	1
		Timer_A3.TA0	1	1
P1.4/SMCLK	4	P1.4 (I/O)	I: 0; O: 1	0
		SMCLK	1	1
P1.5/TA0	5	P1.5 (I/O)	I: 0; O: 1	0
		Timer_A3.CCI0A	0	1
		Timer_A3.TA0	1	1
P1.6/TA1	6	P1.6 (I/O)	I: 0; O: 1	0
		Timer_A3.CCI0A	0	1
		Timer_A3.TA1	1	1
P1.7/TA2	7	P1.7 (I/O)	I: 0; O: 1	0
		Timer_A3.CCI0A	0	1
		Timer_A3.TA2	1	1

MSP430F23x0 MIXED SIGNAL MICROCONTROLLER

SLAS518A - AUGUST 2006 - REVISED MAY 2007

Port P2 pin schematic: P2.0 - P2.4, input/output with Schmitt-trigger

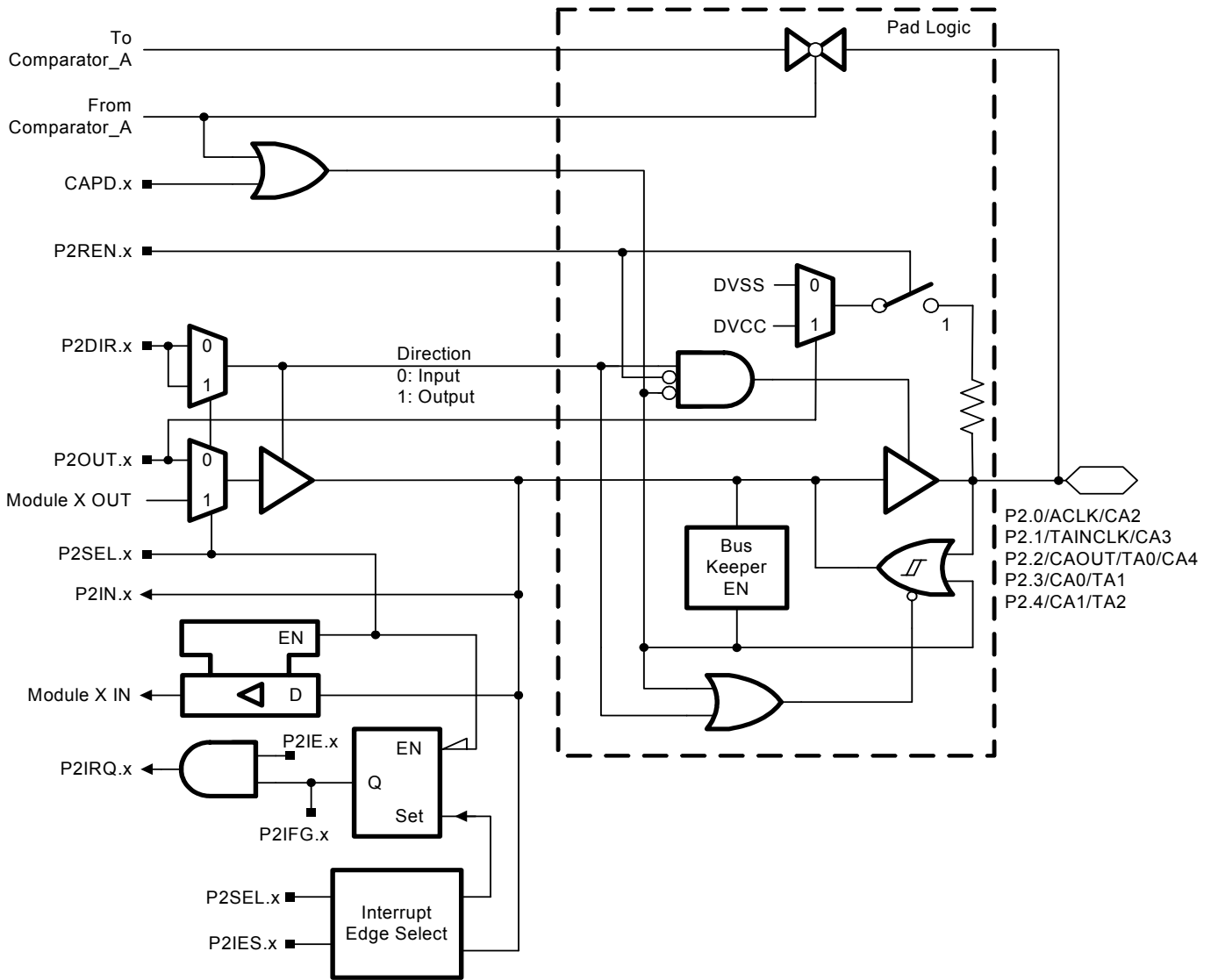

Port P2.0 - P2.4 pin functions

PIN NAME (P2.X)	X	FUNCTION	CONTROL BITS / SIGNALS		
			CAPD.x	P2DIR.x	P2SEL.x
P2.0/ACLK/CA2	0	P2.0 (I/O)	0	I: 0; O: 1	0
		ACLK	0	1	1
		CA2 (see Note 2)	1	X	X
P2.1/TAINCLK/CA3	1	P2.1 (I/O)	0	I: 0; O: 1	0
		Timer_A3.TAINCLK	0	0	1
		DV _{SS}	0	1	1
		CA3 (see Note 2)	1	X	X
P2.2/CAOUT/TA0/ CA4	2	P2.2 (I/O)	0	I: 0; O: 1	0
		CAOUT	0	1	1
		TA0	0	0	1
		CA4 (see Note 2)	1	X	X
P2.3/CA0/TA1	3	P2.3 (I/O)	0	I: 0; O: 1	0
		CA0 (see Note 2)	1	X	X
		Timer_A3.TA1	0	1	1
P2.4/CA1/TA2	4	P2.4 (I/O)	0	I: 0; O: 1	0
		CA1 (see Note 2)	1	X	X
		Timer_A3.TA2	0	1	1

- NOTES: 1. X: Don't care.
 2. Setting the CAPD.x bit disables the output driver as well as the input to prevent parasitic cross currents when applying analog signals. Selecting the CAx input to the comparator multiplexer with the P2CAx bits automatically disables the input buffer for that pin, regardless of the state of the associated CAPD.s bit.

MSP430F23x0 MIXED SIGNAL MICROCONTROLLER

SLAS518A - AUGUST 2006 - REVISED MAY 2007

Port P2 pin schematic: P2.5, input/output with Schmitt-trigger

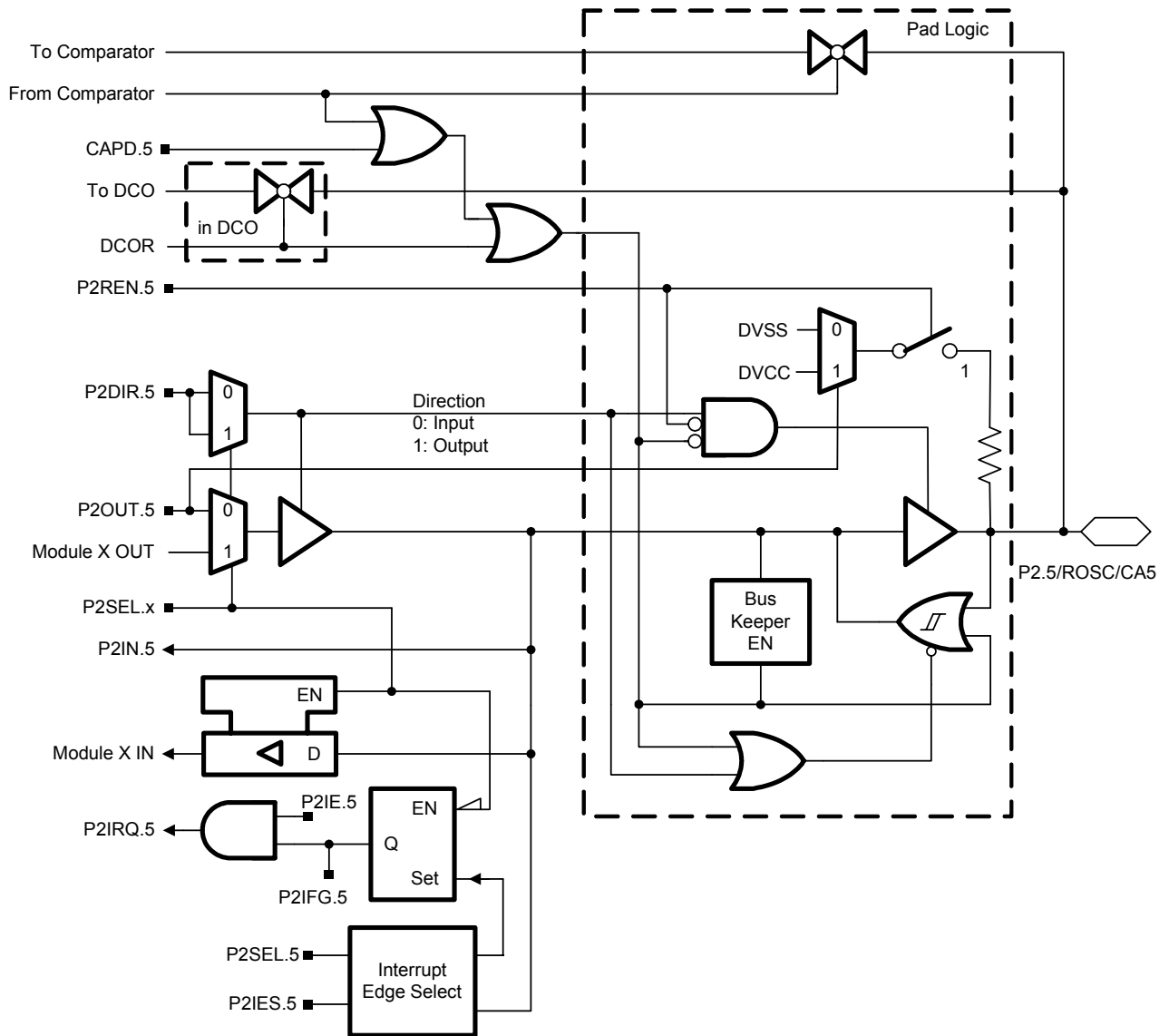

Port P2.5 pin functions

PIN NAME (P2.X)	X	FUNCTION	CONTROL BITS / SIGNALS			
			CAPD.5	DCOR	P2DIR.5	P2SEL.5
P2.5/R _{osc} /CA5	5	P2.5 (I/O)	0	0	I: 0; O: 1	0
		R _{osc}	0	1	X	X
		DV _{ss}	0	0	1	1
		CA5 (see Note 2)	1	0	X	X

NOTES: 1. X: Don't care.

- Setting the CAPD.x bit disables the output driver as well as the input to prevent parasitic cross currents when applying analog signals. Selecting the CAx input to the comparator multiplexer with the P2CAx bits automatically disables the input buffer for that pin, regardless of the state of the associated CAPD.s bit.

Port P2 pin schematic: P2.6, input/output with Schmitt-trigger

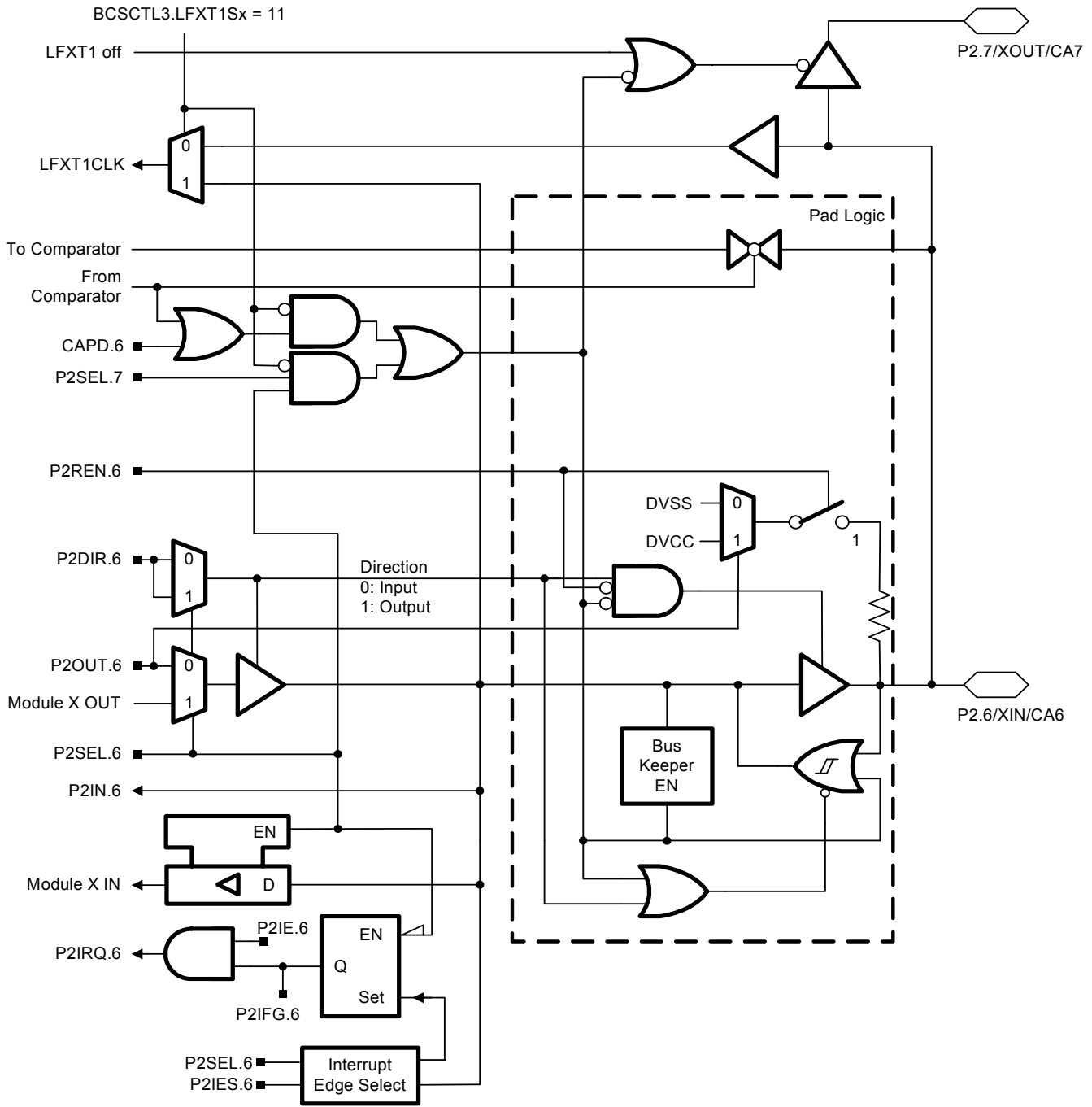

MSP430F23x0 MIXED SIGNAL MICROCONTROLLER

SLAS518A - AUGUST 2006 - REVISED MAY 2007

Port P2.6 pin functions

PIN NAME (P2.X)	X	FUNCTION	CONTROL BITS / SIGNALS		
			CAPD.6	P2DIR.6	P2SEL.6
P2.6/XIN/CA6	6	P2.6 (I/O)	0	I: 0; O: 1	0
		XIN (default)	X	1	1
		CA6 (see Note 2)	1	X	0

- NOTES: 1. X: Don't care.
2. Setting the CAPD.x bit disables the output driver as well as the input to prevent parasitic cross currents when applying analog signals. Selecting the CAx input to the comparator multiplexer with the P2CAx bits automatically disables the input buffer for that pin, regardless of the state of the associated CAPD.s bit.



Port P2 pin schematic: P2.7, input/output with Schmitt-trigger

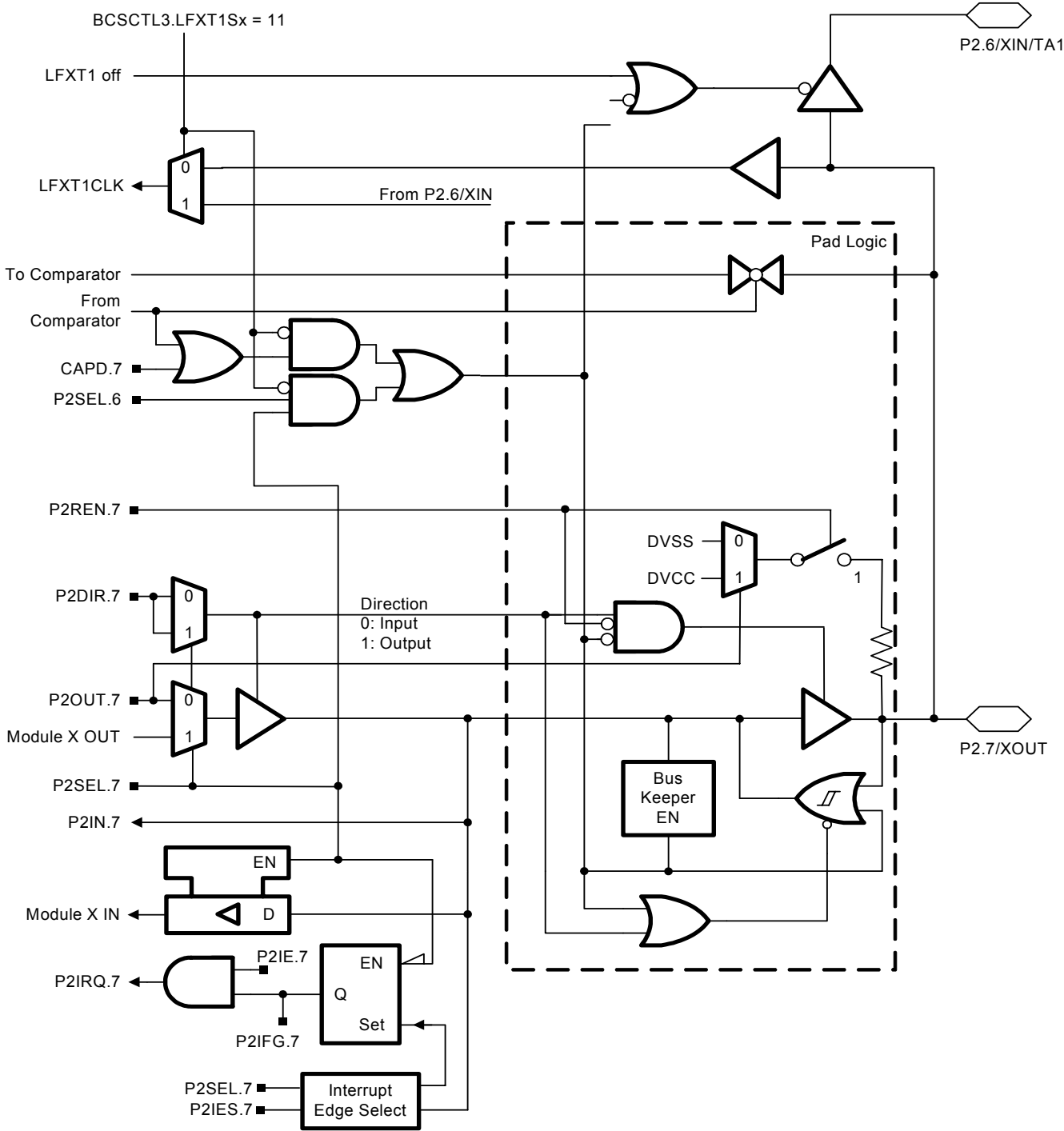

MSP430F23x0 MIXED SIGNAL MICROCONTROLLER

SLAS518A - AUGUST 2006 - REVISED MAY 2007

Port P2.7 pin functions

PIN NAME (P2.X)	X	FUNCTION	CONTROL BITS / SIGNALS		
			CAPD.7	P2DIR.7	P2SEL.7
P2.7/XOUT/CA7	7	P2.7 (I/O)	0	I: 0; O: 1	0
		XOUT (default)	X	1	1
		CA7 (see Note 2)	1	X	0

- NOTES: 1. X: Don't care.
2. Setting the CAPD.x bit disables the output driver as well as the input to prevent parasitic cross currents when applying analog signals. Selecting the CAx input to the comparator multiplexer with the P2CAx bits automatically disables the input buffer for that pin, regardless of the state of the associated CAPD.s bit.



Port P3 pin schematic: P3.0 to P3.5, input/output with Schmitt-trigger

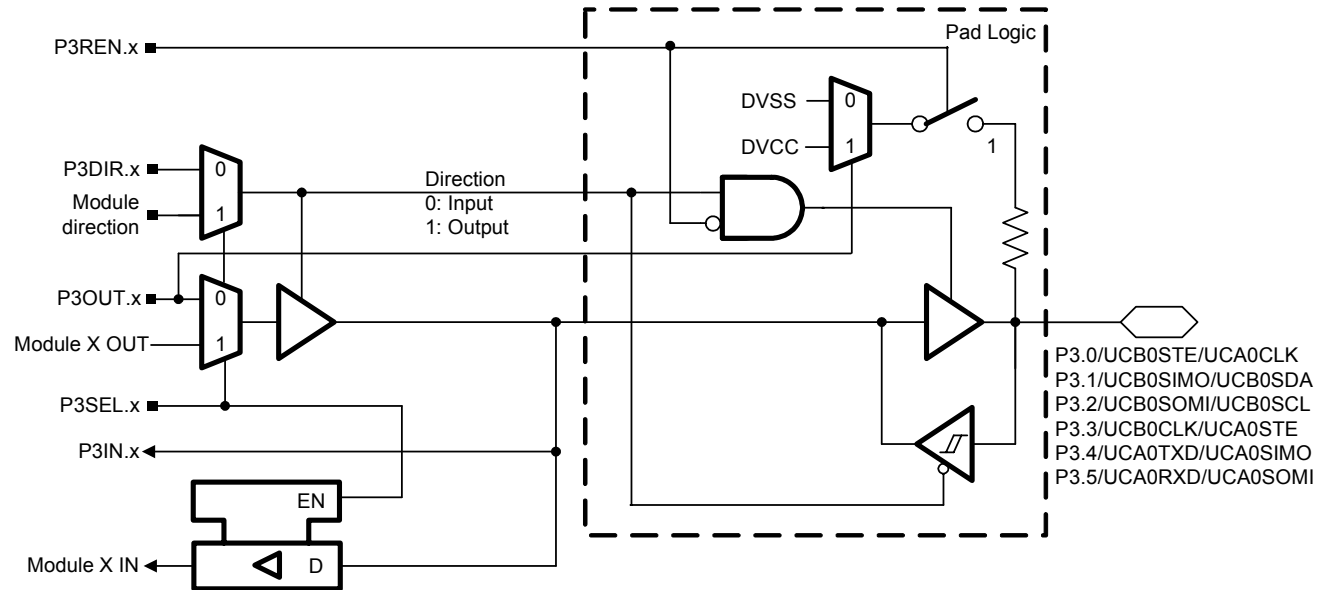

Port P3.0 to P3.5 pin functions

PIN NAME (P3.X)	X	FUNCTION	CONTROL BITS / SIGNALS	
			P3DIR.x	P3SEL.x
P3.0/UCB0STE/ UCA0CLK	0	P3.0 (I/O)	I: 0; O: 1	0
		UCB0STE/UCA0CLK (see Notes 1 and 2)	X	1
P3.1/UCB0SIMO/ UCB0SDA	1	P3.1 (I/O)	I: 0; O: 1	0
		UCB0SIMO/UCB0SDA (see Notes 1, 2 and 3)	X	1
P3.2/UCB0SOMI/ UCB0SCL	2	P3.2 (I/O)	I: 0; O: 1	0
		UCB0SOMI/UCB0SCL (see Notes 1, 2 and 3)	X	1
P3.3/UCB0CLK/ UCA0STE	3	P3.3 (I/O)	I: 0; O: 1	0
		UCB0CLK/UCA0STE (see Notes 1 and 2)	X	1
P3.4/UCA0TXD/ UCA0SIMO	4	P3.4 (I/O)	I: 0; O: 1	0
		UCA0TXD/UCA0SIMO (see Notes 1 and 2)	X	1
P3.5/UCA0RXD/ UCA0SOMI	5	P3.5 (I/O)	I: 0; O: 1	0
		UCA0RXD/UCA0SOMI (see Notes 1 and 2)	X	1

- NOTES: 1. X: Don't care.
 2. The pin direction is controlled by the USCI module.
 3. In case the I2C functionality is selected the output drives only the logical 0 to V_{SS} level.

MSP430F23x0 MIXED SIGNAL MICROCONTROLLER

SLAS518A - AUGUST 2006 - REVISED MAY 2007

Port P3 pin schematic: P3.6 to P3.7, input/output with Schmitt-trigger

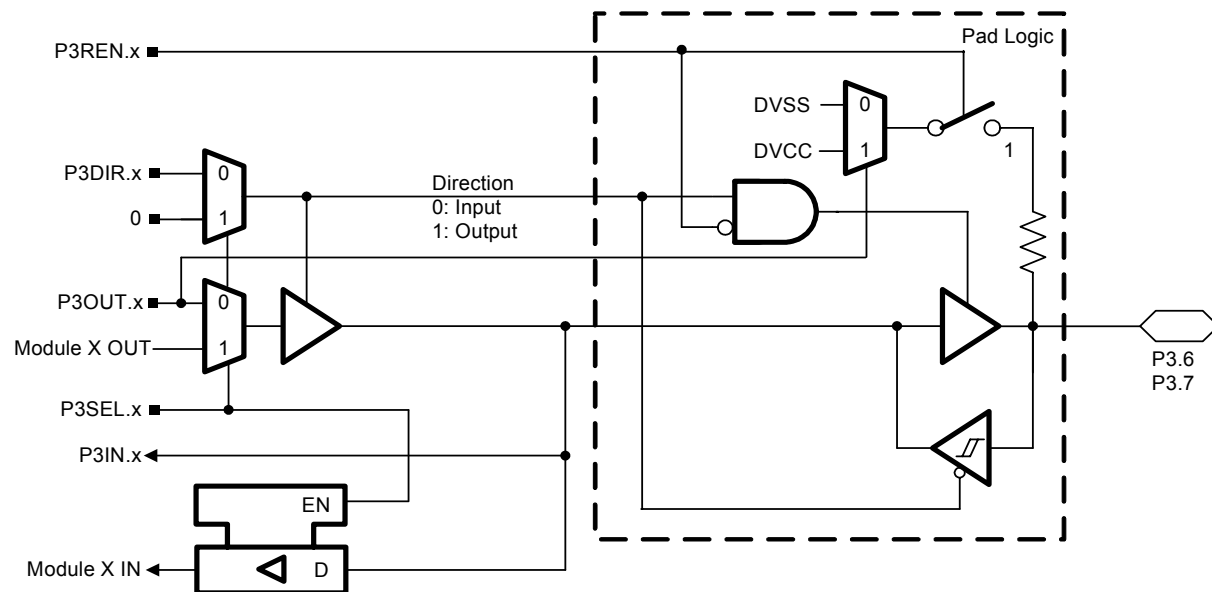

Port P3.6 to P3.7 pin functions

PIN NAME (P3.X)	X	FUNCTION	P3DIR.x	P3SEL.x
P3.6	6	P3.6 (I/O)	I: 0; O: 1	0
P3.7	7	P3.7 (I/O)	I: 0; O: 1	0

Port P4 pin schematic: P4.0 to P4.7, input/output with Schmitt-trigger

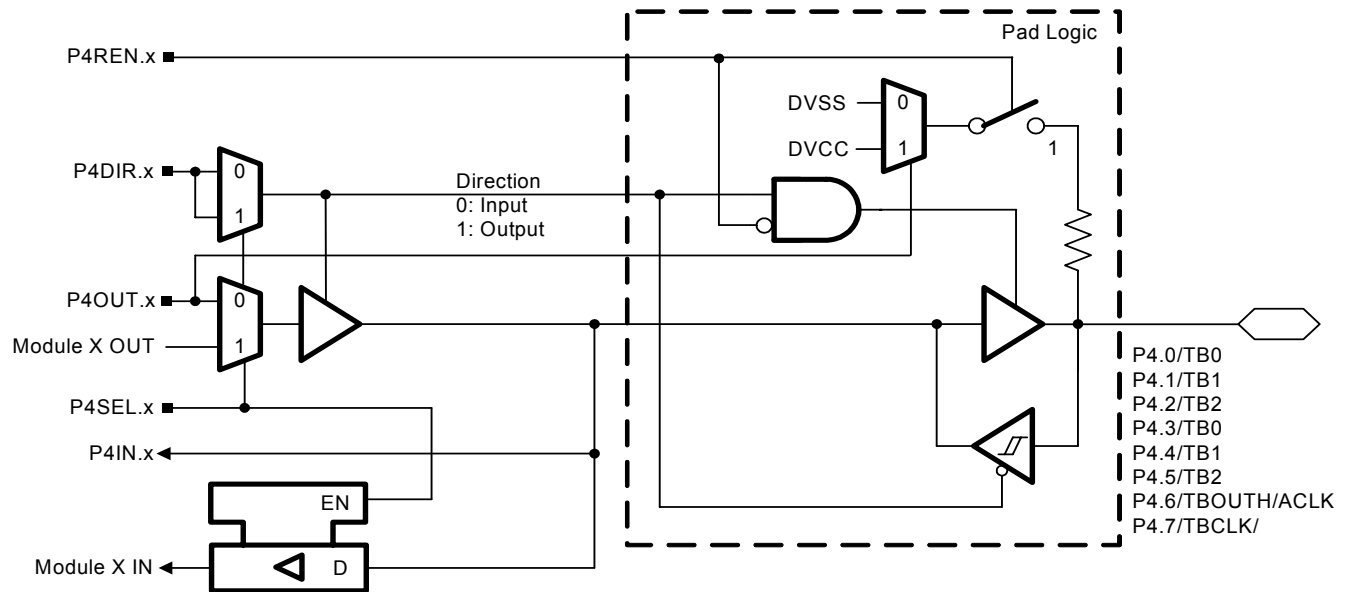

Port P4.0 to P4.7 pin functions

PIN NAME (P4.X)	X	FUNCTION	CONTROL BITS / SIGNALS	
			P4DIR.x	P4SEL.x
P4.0/TB0	0	P4.0 (I/O)	I: 0; O: 1	0
		Timer_B3.CCI0A	0	1
		Timer_B3.OUT0	1	1
P4.1/TB1	1	P4.1 (I/O)	I: 0; O: 1	0
		Timer_B3.CCI1A	0	1
		Timer_B3.OUT1	1	1
P4.2/TB2	2	P4.2 (I/O)	I: 0; O: 1	0
		Timer_B3.CCI2A	0	1
		Timer_B3.OUT2	1	1
P4.3/TB0	3	P4.3 (I/O)	I: 0; O: 1	0
		Timer_B3.CCI0B	0	1
		Timer_B3.OUT0	1	1
P4.4/TB1	4	P4.4 (I/O)	I: 0; O: 1	0
		Timer_B3.CCI1B	0	1
		Timer_B3.OUT1	1	1
P4.5/TB2	5	P4.5 (I/O)	I: 0; O: 1	0
		N/A	0	1
		Timer_B3.OUT2	1	1
P4.6/TBOUTH/ACLK	6	P4.6 (I/O)	I: 0; O: 1	0
		Timer_B3.TBOUTH	0	1
		ACLK	1	1
P4.7/TBCLK	7	P4.7 (I/O)	I: 0; O: 1	0
		Timer_B3.TBCLK	0	1

MSP430F23x0 MIXED SIGNAL MICROCONTROLLER

SLAS518A - AUGUST 2006 - REVISED MAY 2007

APPLICATION INFORMATION

JTAG pins TMS, TCK, TDI/TCLK, TDO/TDI, input/output with Schmitt-trigger

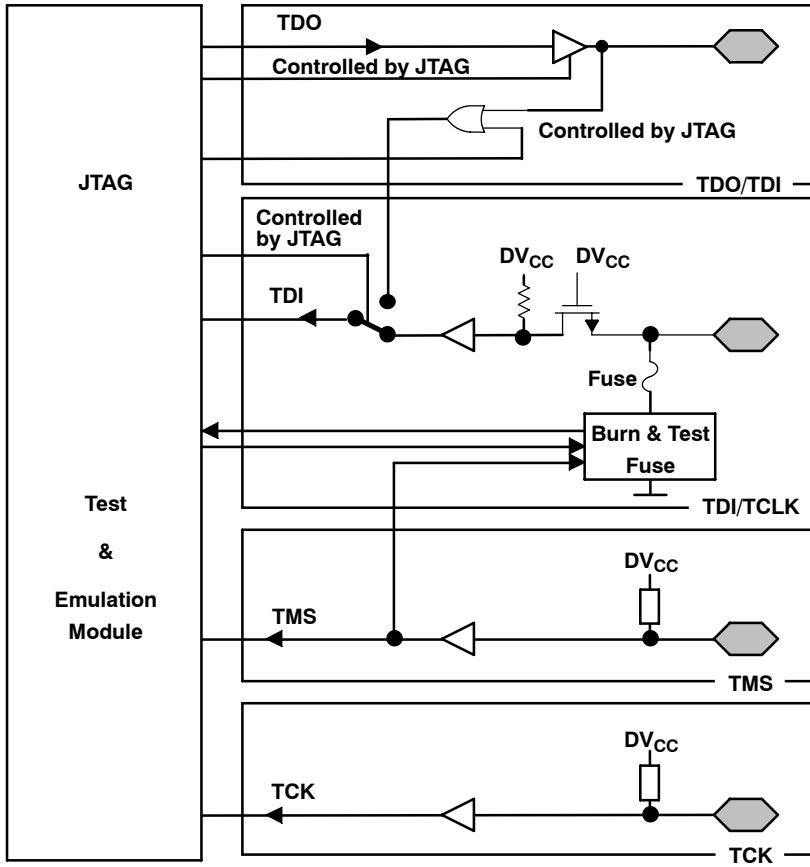

During Programming Activity and During Blowing of the Fuse, Pin TDO/TDI Is Used to Apply the Test Input Data for JTAG Circuitry

APPLICATION INFORMATION

JTAG fuse check mode

MSP430F23x0 devices that have the fuse on the TDI/TCLK terminal have a fuse check mode that tests the continuity of the fuse the first time the JTAG port is accessed after a power-on reset (POR). When activated, a fuse check current, I_{TF} , of 1 mA at 3 V, 2.5 mA at 5 V can flow from the TDI/TCLK pin to ground if the fuse is not burned. Care must be taken to avoid accidentally activating the fuse check mode and increasing overall system power consumption.

Activation of the fuse check mode occurs with the first negative edge on the TMS pin after power up or if the TMS is being held low during power up. The second positive edge on the TMS pin deactivates the fuse check mode. After deactivation, the fuse check mode remains inactive until another POR occurs. After each POR the fuse check mode has the potential to be activated.

The fuse check current will only flow when the fuse check mode is active and the TMS pin is in a low state (see Figure 30). Therefore, the additional current flow can be prevented by holding the TMS pin high (default condition).

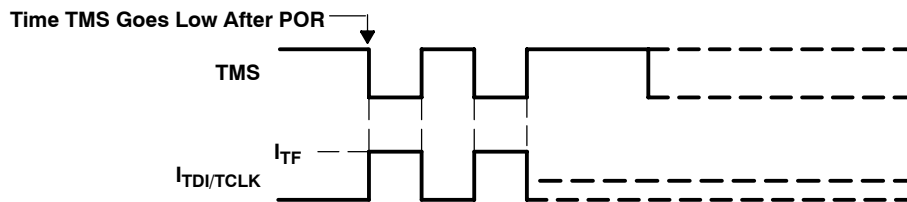

Figure 30. Fuse Check Mode Current

MSP430F23x0 MIXED SIGNAL MICROCONTROLLER

SLAS518A - AUGUST 2006 - REVISED MAY 2007

Data Sheet Revision History

LITERATURE NUMBER	SUMMARY
SLAS518	Preliminary PRODUCT PREVIEW data sheet release.
SLAS518A	PRODUCTION DATA data sheet release.

PACKAGING INFORMATION

Orderable Device	Status ⁽¹⁾	Package Type	Package Drawing	Pins	Package Qty	Eco Plan ⁽²⁾	Lead/Ball Finish	MSL Peak Temp ⁽³⁾
MSP430F2330IRHAR	ACTIVE	QFN	RHA	40	2500	Green (RoHS & no Sb/Br)	CU NIPDAU	Level-3-260C-168 HR
MSP430F2330IRHAT	ACTIVE	QFN	RHA	40	250	Green (RoHS & no Sb/Br)	CU NIPDAU	Level-3-260C-168 HR
MSP430F2330TRHAR	ACTIVE	QFN	RHA	40	2500	Green (RoHS & no Sb/Br)	CU NIPDAU	Level-3-260C-168 HR
MSP430F2330TRHAT	ACTIVE	QFN	RHA	40	250	Green (RoHS & no Sb/Br)	CU NIPDAU	Level-3-260C-168 HR
MSP430F2350IRHAR	ACTIVE	QFN	RHA	40	2500	Green (RoHS & no Sb/Br)	CU NIPDAU	Level-3-260C-168 HR
MSP430F2350IRHAT	ACTIVE	QFN	RHA	40	250	Green (RoHS & no Sb/Br)	CU NIPDAU	Level-3-260C-168 HR
MSP430F2350TRHAR	ACTIVE	QFN	RHA	40	2500	Green (RoHS & no Sb/Br)	CU NIPDAU	Level-3-260C-168 HR
MSP430F2350TRHAT	ACTIVE	QFN	RHA	40	250	Green (RoHS & no Sb/Br)	CU NIPDAU	Level-3-260C-168 HR
MSP430F2370IRHAR	ACTIVE	QFN	RHA	40	2500	Green (RoHS & no Sb/Br)	CU NIPDAU	Level-3-260C-168 HR
MSP430F2370IRHAT	ACTIVE	QFN	RHA	40	250	Green (RoHS & no Sb/Br)	CU NIPDAU	Level-3-260C-168 HR
MSP430F2370TRHAR	ACTIVE	QFN	RHA	40	2500	Green (RoHS & no Sb/Br)	CU NIPDAU	Level-3-260C-168 HR
MSP430F2370TRHAT	ACTIVE	QFN	RHA	40	250	Green (RoHS & no Sb/Br)	CU NIPDAU	Level-3-260C-168 HR

⁽¹⁾ The marketing status values are defined as follows:

ACTIVE: Product device recommended for new designs.

LIFEBUY: TI has announced that the device will be discontinued, and a lifetime-buy period is in effect.

NRND: Not recommended for new designs. Device is in production to support existing customers, but TI does not recommend using this part in a new design.

PREVIEW: Device has been announced but is not in production. Samples may or may not be available.

OBSOLETE: TI has discontinued the production of the device.

⁽²⁾ Eco Plan - The planned eco-friendly classification: Pb-Free (RoHS), Pb-Free (RoHS Exempt), or Green (RoHS & no Sb/Br) - please check <http://www.ti.com/productcontent> for the latest availability information and additional product content details.

TBD: The Pb-Free/Green conversion plan has not been defined.

Pb-Free (RoHS): TI's terms "Lead-Free" or "Pb-Free" mean semiconductor products that are compatible with the current RoHS requirements for all 6 substances, including the requirement that lead not exceed 0.1% by weight in homogeneous materials. Where designed to be soldered at high temperatures, TI Pb-Free products are suitable for use in specified lead-free processes.

Pb-Free (RoHS Exempt): This component has a RoHS exemption for either 1) lead-based flip-chip solder bumps used between the die and package, or 2) lead-based die adhesive used between the die and leadframe. The component is otherwise considered Pb-Free (RoHS compatible) as defined above.

Green (RoHS & no Sb/Br): TI defines "Green" to mean Pb-Free (RoHS compatible), and free of Bromine (Br) and Antimony (Sb) based flame retardants (Br or Sb do not exceed 0.1% by weight in homogeneous material)

⁽³⁾ MSL, Peak Temp. -- The Moisture Sensitivity Level rating according to the JEDEC industry standard classifications, and peak solder temperature.

Important Information and Disclaimer:The information provided on this page represents TI's knowledge and belief as of the date that it is provided. TI bases its knowledge and belief on information provided by third parties, and makes no representation or warranty as to the accuracy of such information. Efforts are underway to better integrate information from third parties. TI has taken and continues to take reasonable steps to provide representative and accurate information but may not have conducted destructive testing or chemical analysis on incoming materials and chemicals. TI and TI suppliers consider certain information to be proprietary, and thus CAS numbers and other limited information may not be available for release.

In no event shall TI's liability arising out of such information exceed the total purchase price of the TI part(s) at issue in this document sold by TI to Customer on an annual basis.

RHA (S-PQFP-N40)

PLASTIC QUAD FLATPACK

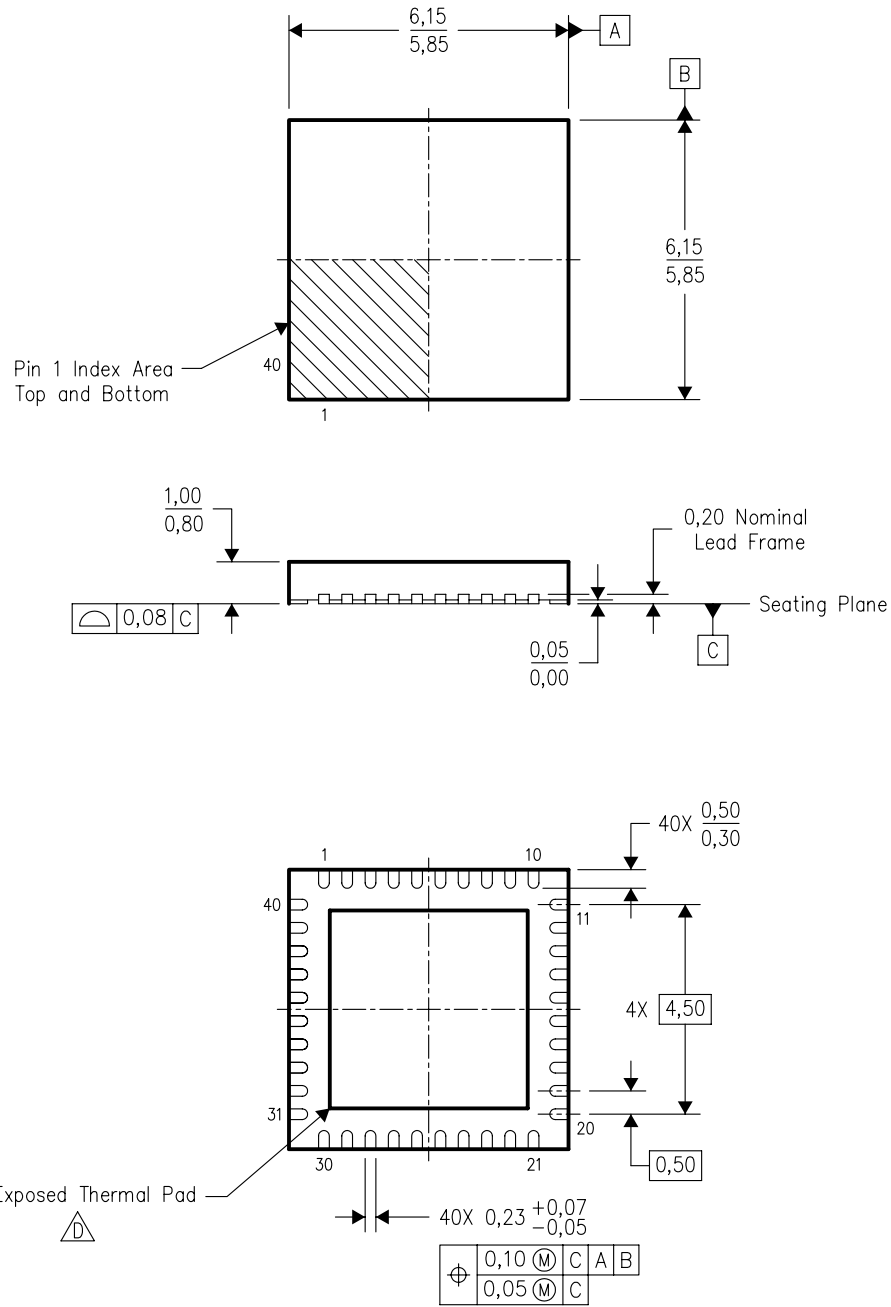

Bottom View

4204276/C 12/2004

- NOTES:
- A. All linear dimensions are in millimeters. Dimensioning and tolerancing per ASME Y14.5M-1994.
 - B. This drawing is subject to change without notice.
 - C. QFN (Quad Flatpack No-Lead) Package configuration.
 -  The package thermal pad must be soldered to the board for thermal and mechanical performance. See the Product Data Sheet for details regarding the exposed thermal pad dimensions.
 - E. Package complies to JEDEC MO-220 variation VJJD-2.

THERMAL INFORMATION

This package incorporates an exposed thermal pad that is designed to be attached directly to an external heatsink. The thermal pad must be soldered directly to the printed circuit board (PCB). After soldering, the PCB can be used as a heatsink. In addition, through the use of thermal vias, the thermal pad can be attached directly to the appropriate copper plane shown in the electrical schematic for the device, or alternatively, can be attached to a special heatsink structure designed into the PCB. This design optimizes the heat transfer from the integrated circuit (IC).

For information on the Quad Flatpack No-Lead (QFN) package and its advantages, refer to Application Report, Quad Flatpack No-Lead Logic Packages, Texas Instruments Literature No. SCBA017. This document is available at www.ti.com.

The exposed thermal pad dimensions for this package are shown in the following illustration.

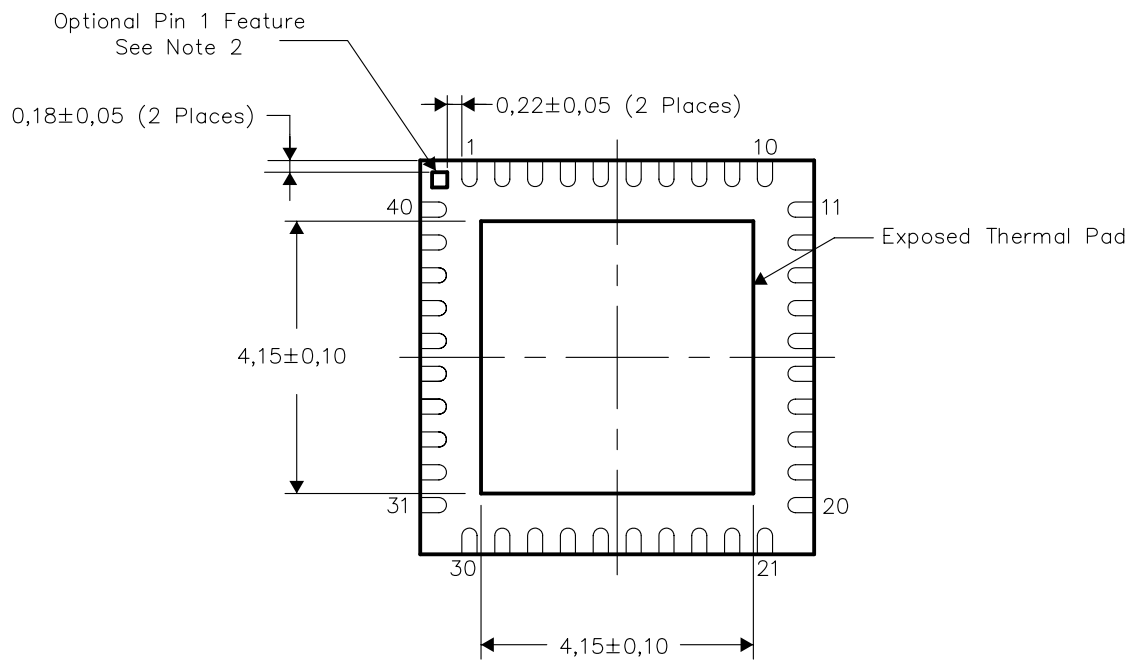

Bottom View

NOTES:

- 1) All linear dimensions are in millimeters
- 2) The Pin 1 Identification mark is an optional feature that may be present on some devices
 In addition, this Pin 1 feature if present is electrically connected to the center thermal pad and therefore should be considered when routing the board layout.

Exposed Thermal Pad Dimensions

RHA (S-PQFP-N40)

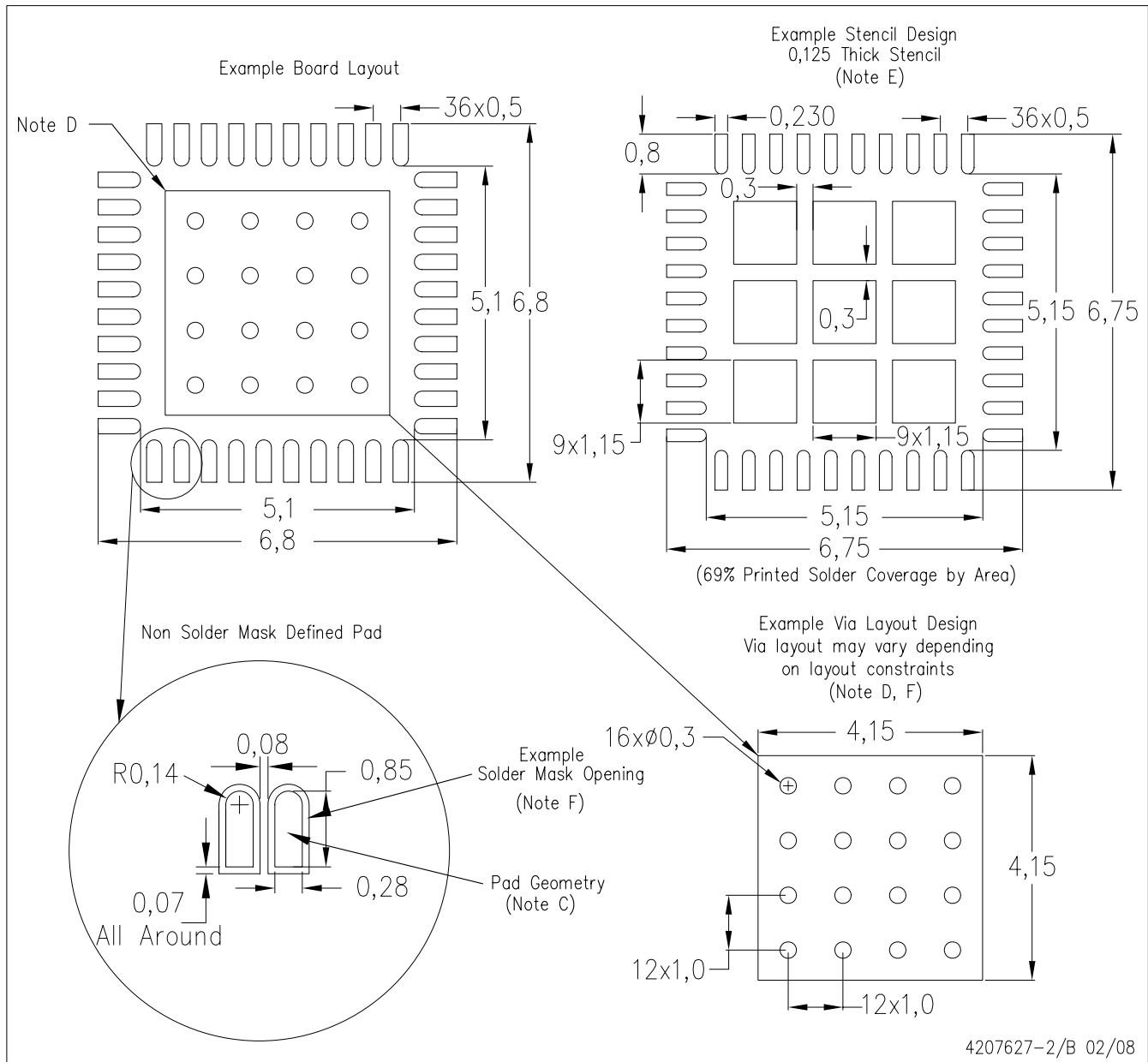

- NOTES:
- A. All linear dimensions are in millimeters.
 - B. This drawing is subject to change without notice.
 - C. Publication IPC-7351 is recommended for alternate designs.
 - D. This package is designed to be soldered to a thermal pad on the board. Refer to Application Note, Quad Flat-Pack Packages, Texas Instruments Literature No. SCBA017, SLUA271, and also the Product Data Sheets for specific thermal information, via requirements, and recommended board layout. These documents are available at www.ti.com <<http://www.ti.com>>.
 - E. Laser cutting apertures with trapezoidal walls and also rounding corners will offer better paste release. Customers should contact their board assembly site for stencil design recommendations. Refer to IPC 7525 for stencil design considerations.
 - F. Customers should contact their board fabrication site for recommended solder mask tolerances and via tenting recommendations for vias placed in the thermal pad.

IMPORTANT NOTICE

Texas Instruments Incorporated and its subsidiaries (TI) reserve the right to make corrections, modifications, enhancements, improvements, and other changes to its products and services at any time and to discontinue any product or service without notice. Customers should obtain the latest relevant information before placing orders and should verify that such information is current and complete. All products are sold subject to TI's terms and conditions of sale supplied at the time of order acknowledgment.

TI warrants performance of its hardware products to the specifications applicable at the time of sale in accordance with TI's standard warranty. Testing and other quality control techniques are used to the extent TI deems necessary to support this warranty. Except where mandated by government requirements, testing of all parameters of each product is not necessarily performed.

TI assumes no liability for applications assistance or customer product design. Customers are responsible for their products and applications using TI components. To minimize the risks associated with customer products and applications, customers should provide adequate design and operating safeguards.

TI does not warrant or represent that any license, either express or implied, is granted under any TI patent right, copyright, mask work right, or other TI intellectual property right relating to any combination, machine, or process in which TI products or services are used. Information published by TI regarding third-party products or services does not constitute a license from TI to use such products or services or a warranty or endorsement thereof. Use of such information may require a license from a third party under the patents or other intellectual property of the third party, or a license from TI under the patents or other intellectual property of TI.

Reproduction of TI information in TI data books or data sheets is permissible only if reproduction is without alteration and is accompanied by all associated warranties, conditions, limitations, and notices. Reproduction of this information with alteration is an unfair and deceptive business practice. TI is not responsible or liable for such altered documentation. Information of third parties may be subject to additional restrictions.

Resale of TI products or services with statements different from or beyond the parameters stated by TI for that product or service voids all express and any implied warranties for the associated TI product or service and is an unfair and deceptive business practice. TI is not responsible or liable for any such statements.

TI products are not authorized for use in safety-critical applications (such as life support) where a failure of the TI product would reasonably be expected to cause severe personal injury or death, unless officers of the parties have executed an agreement specifically governing such use. Buyers represent that they have all necessary expertise in the safety and regulatory ramifications of their applications, and acknowledge and agree that they are solely responsible for all legal, regulatory and safety-related requirements concerning their products and any use of TI products in such safety-critical applications, notwithstanding any applications-related information or support that may be provided by TI. Further, Buyers must fully indemnify TI and its representatives against any damages arising out of the use of TI products in such safety-critical applications.

TI products are neither designed nor intended for use in military/aerospace applications or environments unless the TI products are specifically designated by TI as military-grade or "enhanced plastic." Only products designated by TI as military-grade meet military specifications. Buyers acknowledge and agree that any such use of TI products which TI has not designated as military-grade is solely at the Buyer's risk, and that they are solely responsible for compliance with all legal and regulatory requirements in connection with such use.

TI products are neither designed nor intended for use in automotive applications or environments unless the specific TI products are designated by TI as compliant with ISO/TS 16949 requirements. Buyers acknowledge and agree that, if they use any non-designated products in automotive applications, TI will not be responsible for any failure to meet such requirements.

Following are URLs where you can obtain information on other Texas Instruments products and application solutions:

Products

Amplifiers	amplifier.ti.com
Data Converters	dataconverter.ti.com
DSP	dsp.ti.com
Clocks and Timers	www.ti.com/clocks
Interface	interface.ti.com
Logic	logic.ti.com
Power Mgmt	power.ti.com
Microcontrollers	microcontroller.ti.com
RFID	www.ti-rfid.com
RF/IF and ZigBee® Solutions	www.ti.com/lprf

Applications

Audio	www.ti.com/audio
Automotive	www.ti.com/automotive
Broadband	www.ti.com/broadband
Digital Control	www.ti.com/digitalcontrol
Medical	www.ti.com/medical
Military	www.ti.com/military
Optical Networking	www.ti.com/opticalnetwork
Security	www.ti.com/security
Telephony	www.ti.com/telephony
Video & Imaging	www.ti.com/video
Wireless	www.ti.com/wireless

Mailing Address: Texas Instruments, Post Office Box 655303, Dallas, Texas 75265
Copyright © 2008, Texas Instruments Incorporated