

- Low Supply-Voltage Range, 1.8 V to 3.6 V
- Ultra-Low Power Consumption
 - Active Mode: 200 μ A at 1 MHz, 2.2 V
 - Standby Mode: 0.7 μ A
 - Off Mode (RAM Retention): 0.1 μ A
- Five Power-Saving Modes
- Wake-Up From Standby Mode in Less Than 6 μ s
- Frequency-Locked Loop (FLL+)
- 16-Bit RISC Architecture, 125-ns Instruction Cycle Time
- 16-Bit Timer_A With Three or Five[†] Capture/Compare Registers
- Integrated LCD Driver for 96 Segments
- On-Chip Comparator
- Brownout Detector
- Supply Voltage Supervisor/Monitor – Programmable Level Detection on MSP430F415/417 Devices Only
- Serial Onboard Programming, No External Programming Voltage Needed
- Programmable Code Protection by Security Fuse
- Bootstrap Loader in Flash Devices
- Family Members Include:
 - MSP430C412: 4KB ROM, 256B RAM
 - MSP430C413: 8KB ROM, 256B RAM
 - MSP430F412: 4KB + 256B Flash 256B RAM
 - MSP430F413: 8KB + 256B Flash 256B RAM
 - MSP430F415: 16KB + 256B Flash 512B RAM
 - MSP430F417: 32KB + 256B Flash 1KB RAM
- Available in 64-Pin QFP (PM) and 64-Pin QFN (RTD/RGC) Packages
- For Complete Module Descriptions, Refer to the *MSP430x4xx Family User's Guide*, Literature Number SLAU056

[†] Timer_A5 in 'F415 and 'F417 devices only

description

The Texas Instruments MSP430 family of ultra-low-power microcontrollers consists of several devices featuring different sets of peripherals targeted for various applications. The architecture, combined with five low power modes, is optimized to achieve extended battery life in portable measurement applications. The device features a powerful 16-bit RISC CPU, 16-bit registers, and constant generators that contribute to maximum code efficiency. The digitally controlled oscillator (DCO) allows wake-up from low-power modes to active mode in less than 6 μ s.

The MSP430x41x series are microcontroller configurations with one or two built-in 16-bit timers, a comparator, 96 LCD segment drive capability, and 48 I/O pins.

Typical applications include sensor systems that capture analog signals, convert them to digital values, and process the data and transmit them to a host system. The comparator and timer make the configurations ideal for industrial meters, counter applications, handheld meters, etc.



This integrated circuit can be damaged by ESD. Texas Instruments recommends that all integrated circuits be handled with appropriate precautions. Failure to observe proper handling and installation procedures can cause damage. ESD damage can range from subtle performance degradation to complete device failure. Precision integrated circuits may be more susceptible to damage because very small parametric changes could cause the device not to meet its published specifications. These devices have limited built-in ESD protection.



Please be aware that an important notice concerning availability, standard warranty, and use in critical applications of Texas Instruments semiconductor products and disclaimers thereto appears at the end of this data sheet.

PRODUCTION DATA information is current as of publication date. Products conform to specifications per the terms of Texas Instruments standard warranty. Production processing does not necessarily include testing of all parameters.

**TEXAS
INSTRUMENTS**

POST OFFICE BOX 655303 • DALLAS, TEXAS 75265

Copyright © 2007, Texas Instruments Incorporated

MSP430x41x MIXED SIGNAL MICROCONTROLLER

SLAS340I – MAY 2001 – REVISED MARCH 2008

AVAILABLE OPTIONS

T _A	PACKAGED DEVICES	
	PLASTIC 64-PIN QFP (PM)	PLASTIC 64-PIN QFN (RTD/RGC)
-40°C to 85°C	MSP430C412IPM	MSP430C412IRGC
	MSP430C413IPM	MSP430C413IRGC
	MSP430F412IPM	MSP430F412IRTD
	MSP430F413IPM	MSP430F413IRTD
	MSP430F415IPM	MSP430F415IRTD
	MSP430F417IPM	MSP430F417IRTD

pin designation – MSP430x412, MSP430x413

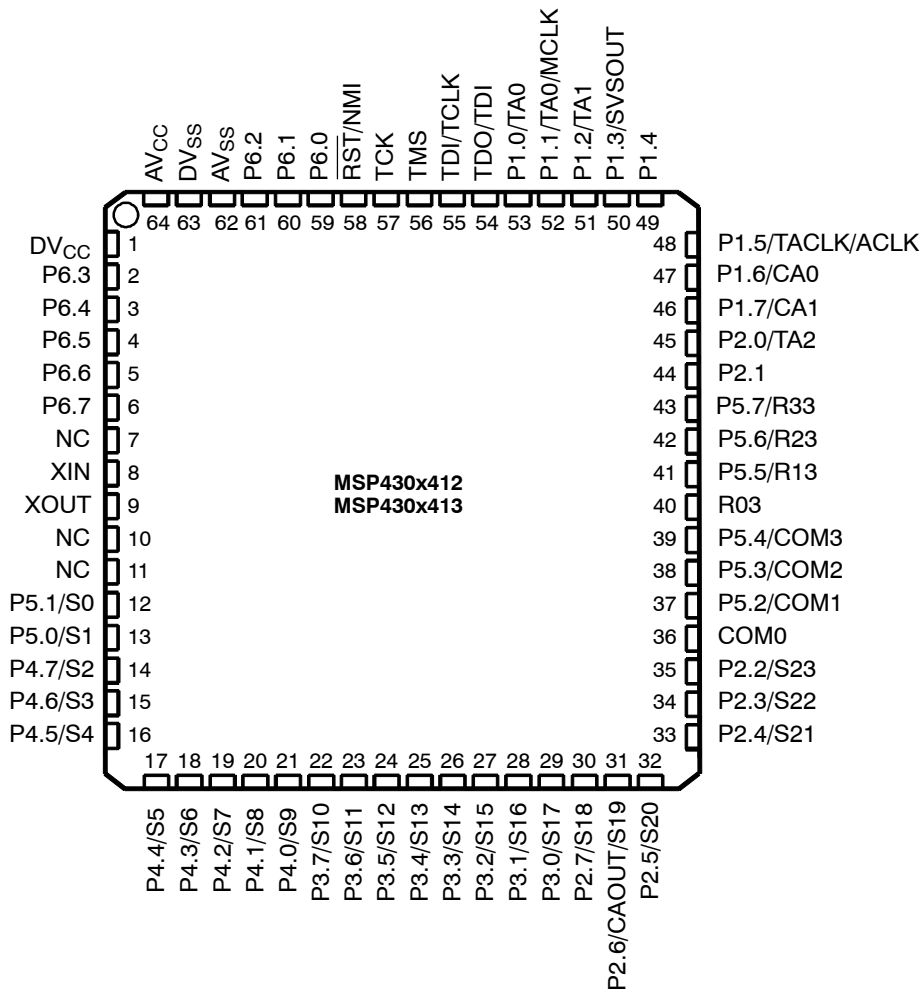

NC – No internal connection. External connection to V_{SS} recommended.



POST OFFICE BOX 655303 • DALLAS, TEXAS 75265

MSP430x41x MIXED SIGNAL MICROCONTROLLER

SLAS340I – MAY 2001 – REVISED MARCH 2008

pin designation – MSP430x415, MSP430x417

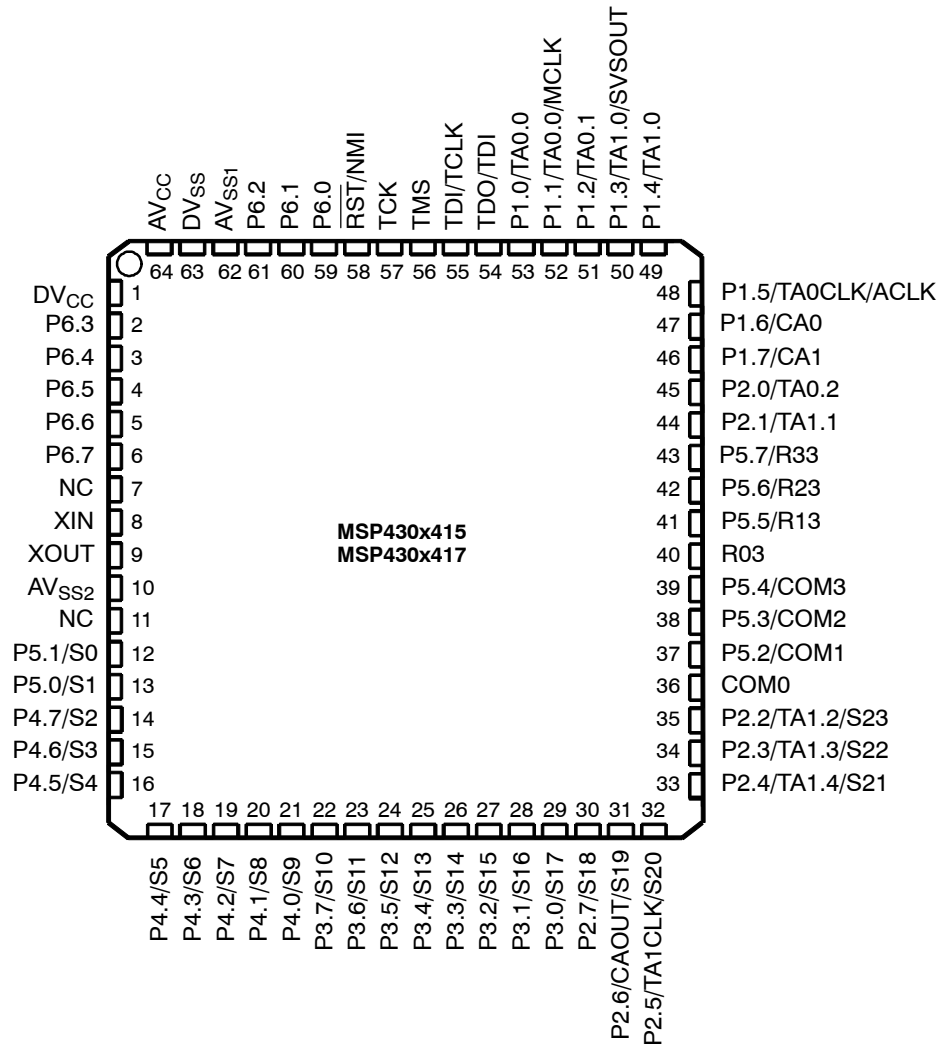

NC – No internal connection. External connection to V_{SS} recommended.

MSP430x41x MIXED SIGNAL MICROCONTROLLER

SLAS340I – MAY 2001 – REVISED MARCH 2008

functional block diagram – MSP430x412, MSP430x413

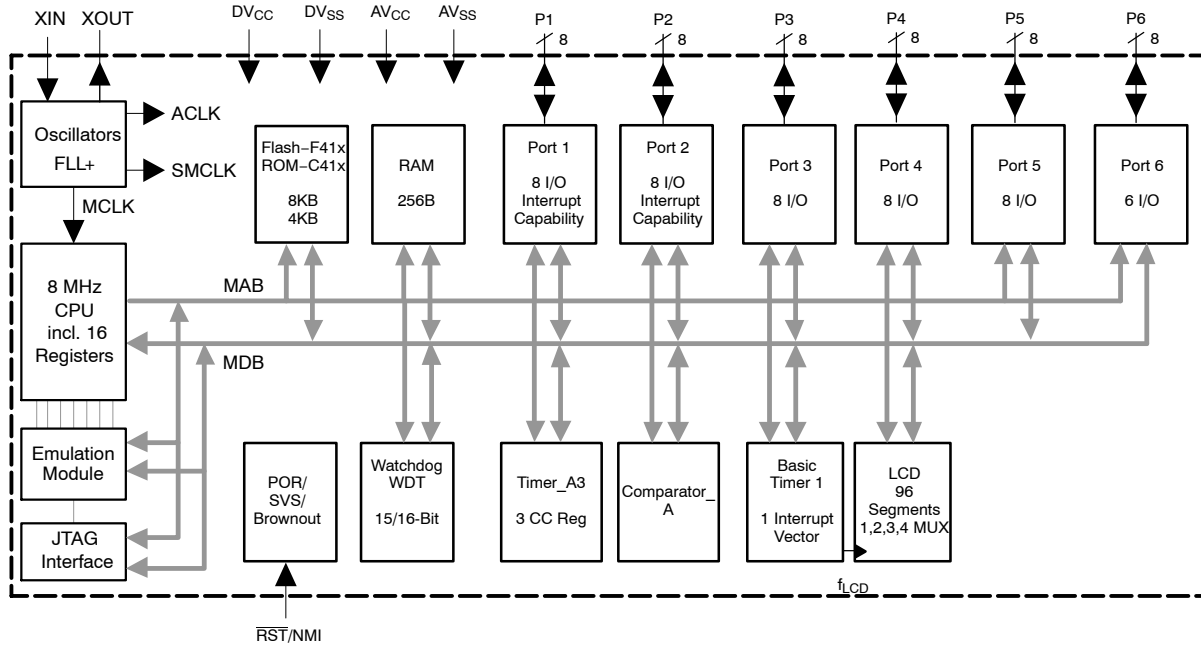

functional block diagram – MSP430x415, MSP430x417

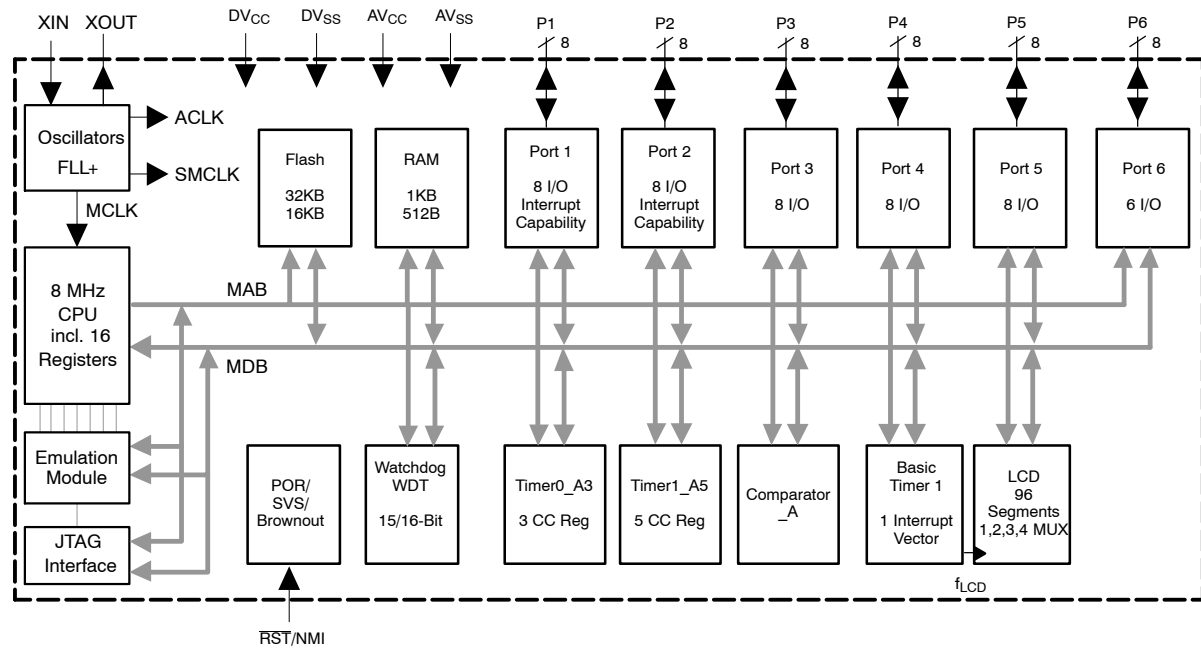

Terminal Functions – MSP430x412, MSP430x413

TERMINAL NAME	NO.	I/O	DESCRIPTION
AV _{CC}	64		Positive terminal that supplies SVS, brownout, oscillator, comparator_A, port 1, and LCD resistive divider circuitry; must not power up prior to DV _{CC} .
AV _{SS}	62		Negative terminal that supplies SVS, brownout, oscillator, comparator_A. Needs to be externally connected to DV _{SS} .
DV _{CC}	1		Digital supply voltage, positive terminal. Supplies all parts, except those which are supplied via AV _{CC} .
DV _{SS}	63		Digital supply voltage, negative terminal. Supplies all digital parts, except those which are supplied via AV _{CC} /AV _{SS} .
NC	7, 10, 11		Not internally connected. Connection to V _{SS} recommended.
P1.0/TA0	53	I/O	General-purpose digital I/O / Timer_A, Capture: CCI0A input, compare: Out0 output/BSL transmit
P1.1/TA0/MCLK	52	I/O	General-purpose digital I/O / Timer_A, Capture: CCI0B input/MCLK output. Note: TA0 is only an input on this pin/BSL receive.
P1.2/TA1	51	I/O	General-purpose digital I/O / Timer_A, Capture: CCI1A input, compare: Out1 output
P1.3/SVSOUT	50	I/O	General-purpose digital I/O / SVS: output of SVS comparator
P1.4	49	I/O	General-purpose digital I/O
P1.5/TACLK/ ACLK	48	I/O	General-purpose digital I/O / Input of Timer_A clock/output of ACLK
P1.6/CA0	47	I/O	General-purpose digital I/O / Comparator_A input
P1.7/CA1	46	I/O	General-purpose digital I/O / Comparator_A input
P2.0/TA2	45	I/O	General-purpose digital I/O / Timer_A capture: CCI2A input, compare: Out2 output
P2.1	44	I/O	General-purpose digital I/O
P2.2/S23	35	I/O	General-purpose digital I/O / LCD segment output 23 (see Note 1)
P2.3/S22	34	I/O	General-purpose digital I/O / LCD segment output 22 (see Note 1)
P2.4/S21	33	I/O	General-purpose digital I/O / LCD segment output 21 (see Note 1)
P2.5/S20	32	I/O	General-purpose digital I/O / LCD segment output 20 (see Note 1)
P2.6/CAOUT/S19	31	I/O	General-purpose digital I/O / Comparator_A output/LCD segment output 19 (see Note 1)
P2.7/S18	30	I/O	General-purpose digital I/O / LCD segment output 18 (see Note 1)
P3.0/S17	29	I/O	General-purpose digital I/O / LCD segment output 17 (see Note 1)
P3.1/S16	28	I/O	General-purpose digital I/O / LCD segment output 16 (see Note 1)
P3.2/S15	27	I/O	General-purpose digital I/O / LCD segment output 15 (see Note 1)
P3.3/S14	26	I/O	General-purpose digital I/O / LCD segment output 14 (see Note 1)
P3.4/S13	25	I/O	General-purpose digital I/O / LCD segment output 13 (see Note 1)
P3.5/S12	24	I/O	General-purpose digital I/O / LCD segment output 12 (see Note 1)
P3.6/S11	23	I/O	General-purpose digital I/O / LCD segment output 11 (see Note 1)
P3.7/S10	22	I/O	General-purpose digital I/O / LCD segment output 10 (see Note 1)

NOTE 1: LCD function selected automatically when applicable LCD module control bits are set, not with PxSEL bits.

MSP430x41x MIXED SIGNAL MICROCONTROLLER

SLAS340I – MAY 2001 – REVISED MARCH 2008

Terminal Functions – MSP430x412, MSP430x413 (Continued)

TERMINAL NAME	NO.	I/O	DESCRIPTION
P4.0/S9	21	I/O	General-purpose digital I/O / LCD segment output 9 (see Note 1)
P4.1/S8	20	I/O	General-purpose digital I/O / LCD segment output 8 (see Note 1)
P4.2/S7	19	I/O	General-purpose digital I/O / LCD segment output 7 (see Note 1)
P4.3/S6	18	I/O	General-purpose digital I/O / LCD segment output 6 (see Note 1)
P4.4/S5	17	I/O	General-purpose digital I/O / LCD segment output 5 (see Note 1)
P4.5/S4	16	I/O	General-purpose digital I/O / LCD segment output 4 (see Note 1)
P4.6/S3	15	I/O	General-purpose digital I/O / LCD segment output 3 (see Note 1)
P4.7/S2	14	I/O	General-purpose digital I/O / LCD segment output 2 (see Note 1)
P5.0/S1	13	I/O	General-purpose digital I/O / LCD segment output 1 (see Note 1)
P5.1/S0	12	I/O	General-purpose digital I/O / LCD segment output 0 (see Note 1)
COM0	36	O	Common output. COM0–3 are used for LCD backplanes
P5.2/COM1	37	I/O	General-purpose digital I/O / Common output. COM0–3 are used for LCD backplanes.
P5.3/COM2	38	I/O	General-purpose digital I/O / Common output. COM0–3 are used for LCD backplanes.
P5.4/COM3	39	I/O	General-purpose digital I/O / Common output. COM0–3 are used for LCD backplanes.
R03	40	I	Input port of fourth positive (lowest) analog LCD level (V5)
P5.5/R13	41	I/O	General-purpose digital I/O / Input port of third most positive analog LCD level (V4 or V3)
P5.6/R23	42	I/O	General-purpose digital I/O / Input port of second most positive analog LCD level (V2)
P5.7/R33	43	I/O	General-purpose digital I/O / Output port of most positive analog LCD level (V1)
P6.0	59	I/O	General-purpose digital I/O
P6.1	60	I/O	General-purpose digital I/O
P6.2	61	I/O	General-purpose digital I/O
P6.3	2	I/O	General-purpose digital I/O
P6.4	3	I/O	General-purpose digital I/O
P6.5	4	I/O	General-purpose digital I/O
P6.6	5	I/O	General-purpose digital I/O
P6.7	6	I/O	General-purpose digital I/O
RST/NMI	58	I	Reset input / Nonmaskable interrupt input
TCK	57	I	Test clock. TCK is the clock input port for device programming and test.
TDI/TCLK	55	I	Test data input / Test clock input. The device protection fuse is connected to TDI.
TDO/TDI	54	I/O	Test data output port. TDO/TDI data output or programming data input terminal.
TMS	56	I	Test mode select. TMS is used as an input port for device programming and test.
XIN	8	I	Input port for crystal oscillator XT1. Standard or watch crystals can be connected.
XOUT	9	O	Output terminal of crystal oscillator XT1.
QFN Pad	NA	NA	QFN package pad connection to V _{SS} recommended.

NOTE 2: LCD function selected automatically when applicable LCD module control bits are set, not with PxSEL bits.



Terminal Functions – MSP430x415, MSP430x417

TERMINAL NAME	NO.	I/O	DESCRIPTION
AV _{CC}	64		Positive terminal that supplies SVS, brownout, oscillator, comparator_A, port 1, and LCD resistive divider circuitry; must not power up prior to DV _{CC} .
AV _{SS1}	62		Negative terminal that supplies SVS, brownout, oscillator, comparator_A. Needs to be externally connected to DV _{SS} .
DV _{CC}	1		Digital supply voltage, positive terminal. Supplies all parts, except those which are supplied via AV _{CC} .
DV _{SS}	63		Digital supply voltage, negative terminal. Supplies all digital parts, except those which are supplied via AV _{CC} /AV _{SS} .
AV _{SS2}	10		Negative terminal that supplies SVS, brownout, oscillator, comparator_A. Needs to be externally connected to DV _{SS} .
NC	7, 11		Not internally connected. Connection to V _{SS} recommended.
P1.0/TA0.0	53	I/O	General-purpose digital I/O / Timer0_A. Capture: CCI0A input, compare: Out0 output/BSL transmit
P1.1/TA0.0/MCLK	52	I/O	General-purpose digital I/O / Timer0_A. Capture: CCI0B input/MCLK output. Note: TA0 is only an input on this pin/BSL receive
P1.2/TA0.1	51	I/O	General-purpose digital I/O / Timer0_A, capture: CCI1A input, compare: Out1 output
P1.3/TA1.0/ SVSOUT	50	I/O	General-purpose digital I/O / Timer1_A, capture: CCI0B input/SVS: output of SVS comparator
P1.4/TA1.0	49	I/O	General-purpose digital I/O / Timer1_A, capture: CCI0A input, compare: Out0 output
P1.5/TA0CLK/ ACLK	48	I/O	General-purpose digital I/O / input of Timer0_A clock/output of ACLK
P1.6/CA0	47	I/O	General-purpose digital I/O / Comparator_A input
P1.7/CA1	46	I/O	General-purpose digital I/O / Comparator_A input
P2.0/TA0.2	45	I/O	General-purpose digital I/O / Timer0_A capture: CCI2A input, compare: Out2 output
P2.1/TA1.1	44	I/O	General-purpose digital I/O / Timer1_A, capture: CCI1A input, compare: Out1 output
P2.2/TA1.2/S23	35	I/O	General-purpose digital I/O / Timer1_A, capture: CCI2A input, compare: Out2 output/LCD segment output 23 (see Note 1)
P2.3/TA1.3/S22	34	I/O	General-purpose digital I/O / Timer1_A, capture: CCI3A input, compare: Out3 output/LCD segment output 22 (see Note 1)
P2.4/TA1.4/S21	33	I/O	General-purpose digital I/O / Timer1_A, capture: CCI4A input, compare: Out4 output/LCD segment output 21 (see Note 1)
P2.5/TA1CLK/S20	32	I/O	General-purpose digital I/O / input of Timer1_A clock/LCD segment output 20 (see Note 1)
P2.6/CAOUT/S19	31	I/O	General-purpose digital I/O / Comparator_A output/LCD segment output 19 (see Note 1)
P2.7/S18	30	I/O	General-purpose digital I/O / LCD segment output 18 (see Note 1)
P3.0/S17	29	I/O	General-purpose digital I/O / LCD segment output 17 (see Note 1)
P3.1/S16	28	I/O	General-purpose digital I/O / LCD segment output 16 (see Note 1)
P3.2/S15	27	I/O	General-purpose digital I/O / LCD segment output 15 (see Note 1)
P3.3/S14	26	I/O	General-purpose digital I/O / LCD segment output 14 (see Note 1)
P3.4/S13	25	I/O	General-purpose digital I/O / LCD segment output 13 (see Note 1)
P3.5/S12	24	I/O	General-purpose digital I/O / LCD segment output 12 (see Note 1)
P3.6/S11	23	I/O	General-purpose digital I/O / LCD segment output 11 (see Note 1)
P3.7/S10	22	I/O	General-purpose digital I/O / LCD segment output 10 (see Note 1)

NOTE 3: LCD function selected automatically when applicable LCD module control bits are set, not with PxSEL bits.

MSP430x41x MIXED SIGNAL MICROCONTROLLER

SLAS340I – MAY 2001 – REVISED MARCH 2008

Terminal Functions – MSP430x415, MSP430x417 (Continued)

TERMINAL NAME	NO.	I/O	DESCRIPTION
P4.0/S9	21	I/O	General-purpose digital I/O / LCD segment output 9 (see Note 1)
P4.1/S8	20	I/O	General-purpose digital I/O / LCD segment output 8 (see Note 1)
P4.2/S7	19	I/O	General-purpose digital I/O / LCD segment output 7 (see Note 1)
P4.3/S6	18	I/O	General-purpose digital I/O / LCD segment output 6 (see Note 1)
P4.4/S5	17	I/O	General-purpose digital I/O / LCD segment output 5 (see Note 1)
P4.5/S4	16	I/O	General-purpose digital I/O / LCD segment output 4 (see Note 1)
P4.6/S3	15	I/O	General-purpose digital I/O / LCD segment output 3 (see Note 1)
P4.7/S2	14	I/O	General-purpose digital I/O / LCD segment output 2 (see Note 1)
P5.0/S1	13	I/O	General-purpose digital I/O / LCD segment output 1 (see Note 1)
P5.1/S0	12	I/O	General-purpose digital I/O / LCD segment output 0 (see Note 1)
COM0	36	O	Common output. COM0–3 are used for LCD backplanes.
P5.2/COM1	37	I/O	General-purpose digital I/O / common output. COM0–3 are used for LCD backplanes.
P5.3/COM2	38	I/O	General-purpose digital I/O / common output. COM0–3 are used for LCD backplanes.
P5.4/COM3	39	I/O	General-purpose digital I/O / common output. COM0–3 are used for LCD backplanes.
R03	40	I	Input port of fourth positive (lowest) analog LCD level (V5)
P5.5/R13	41	I/O	General-purpose digital I/O / input port of third most positive analog LCD level (V4 or V3)
P5.6/R23	42	I/O	General-purpose digital I/O / input port of second most positive analog LCD level (V2)
P5.7/R33	43	I/O	General-purpose digital I/O / output port of most positive analog LCD level (V1)
P6.0	59	I/O	General-purpose digital I/O
P6.1	60	I/O	General-purpose digital I/O
P6.2	61	I/O	General-purpose digital I/O
P6.3	2	I/O	General-purpose digital I/O
P6.4	3	I/O	General-purpose digital I/O
P6.5	4	I/O	General-purpose digital I/O
P6.6	5	I/O	General-purpose digital I/O
P6.7/SVSIN	6	I/O	General-purpose digital I/O / SVS, analog input
RST/NMI	58	I	Reset input / Nonmaskable interrupt input port
TCK	57	I	Test clock. TCK is the clock input port for device programming and test.
TDI/TCLK	55	I	Test data input / Test clock input. The device protection fuse is connected to TDI.
TDO/TDI	54	I/O	Test data output port. TDO/TDI data output or programming data input terminal.
TMS	56	I	Test mode select. TMS is used as an input port for device programming and test.
XIN	8	I	Input port for crystal oscillator XT1. Standard or watch crystals can be connected.
XOUT	9	O	Output terminal of crystal oscillator XT1.
QFN Pad	NA	NA	QFN package pad connection to V _{SS} recommended

NOTE 4: LCD function selected automatically when applicable LCD module control bits are set, not with PxSEL bits.



short-form description

CPU

The MSP430 CPU has a 16-bit RISC architecture that is highly transparent to the application. All operations, other than program-flow instructions, are performed as register operations in conjunction with seven addressing modes for source operand and four addressing modes for destination operand.

The CPU is integrated with 16 registers that provide reduced instruction execution time. The register-to-register operation execution time is one cycle of the CPU clock.

Four of the registers, R0 to R3, are dedicated as program counter, stack pointer, status register, and constant generator, respectively. The remaining registers are general-purpose registers.

Peripherals are connected to the CPU using data, address, and control buses, and can be handled with all instructions.

Program Counter	PC/R0
Stack Pointer	SP/R1
Status Register	SR/CG1/R2
Constant Generator	CG2/R3
General-Purpose Register	R4
General-Purpose Register	R5
General-Purpose Register	R6
General-Purpose Register	R7
General-Purpose Register	R8
General-Purpose Register	R9
General-Purpose Register	R10
General-Purpose Register	R11
General-Purpose Register	R12
General-Purpose Register	R13
General-Purpose Register	R14
General-Purpose Register	R15

instruction set

The instruction set consists of 51 instructions with three formats and seven address modes. Each instruction can operate on word and byte data. Table 1 shows examples of the three types of instruction formats; the address modes are listed in Table 2.

Table 1. Instruction Word Formats

Dual operands, source-destination	e.g. ADD R4,R5	R4 + R5 ----> R5
Single operands, destination only	e.g. CALL R8	PC -->(TOS), R8--> PC
Relative jump, un/conditional	e.g. JNE	Jump-on-equal bit = 0

Table 2. Address Mode Descriptions

ADDRESS MODE	S	D	SYNTAX	EXAMPLE	OPERATION
Register	●	●	MOV Rs,Rd	MOV R10,R11	R10 --> R11
Indexed	●	●	MOV X(Rn),Y(Rm)	MOV 2(R5),6(R6)	M(2+R5)--> M(6+R6)
Symbolic (PC relative)	●	●	MOV EDE,TONI		M(EDE) --> M(TONI)
Absolute	●	●	MOV &MEM,&TCDAT		M(MEM) --> M(TCDAT)
Indirect	●		MOV @Rn,Y(Rm)	MOV @R10,Tab(R6)	M(R10) --> M(Tab+R6)
Indirect autoincrement	●		MOV @Rn+,Rm	MOV @R10+,R11	M(R10) --> R11 R10 + 2--> R10
Immediate	●		MOV #X,TONI	MOV #45,TONI	#45 --> M(TONI)

NOTE: S = source D = destination

MSP430x41x

MIXED SIGNAL MICROCONTROLLER

SLAS340I – MAY 2001 – REVISED MARCH 2008

operating modes

The MSP430 has one active mode and five software selectable low-power modes of operation. An interrupt event can wake up the device from any of the five low-power modes, service the request and restore back to the low-power mode on return from the interrupt program.

The following six operating modes can be configured by software:

- Active mode (AM)
 - All clocks are active
- Low-power mode 0 (LPM0)
 - CPU is disabled
ACLK and SMCLK remain active, MCLK is available to modules
FLL+ loop control remains active
- Low-power mode 1 (LPM1)
 - CPU is disabled
ACLK and SMCLK remain active, MCLK is available to modules
FLL+ loop control is disabled
- Low-power mode 2 (LPM2)
 - CPU is disabled
MCLK, FLL+ loop control, and DCOCLK are disabled
DCO's dc generator remains enabled
ACLK remains active
- Low-power mode 3 (LPM3)
 - CPU is disabled
MCLK, FLL+ loop control, and DCOCLK are disabled
DCO's dc generator is disabled
ACLK remains active
- Low-power mode 4 (LPM4)
 - CPU is disabled
ACLK is disabled
MCLK, FLL+ loop control, and DCOCLK are disabled
DCO's dc generator is disabled
Crystal oscillator is stopped



interrupt vector addresses

The interrupt vectors and the power-up starting address are located in the address range of 0FFFFh to 0FFE0h. The vector contains the 16-bit address of the appropriate interrupt-handler instruction sequence.

INTERRUPT SOURCE	INTERRUPT FLAG	SYSTEM INTERRUPT	WORD ADDRESS	PRIORITY
Power-up External reset Watchdog Flash memory	WDTIFG KEYV (see Note 1)	Reset	0FFFEh	15, highest
NMI Oscillator fault Flash memory access violation	NMIIFG (see Notes 1 and 3) OFIFG (see Notes 1 and 3) ACCVIFG (see Notes 1 and 3)	(Non)maskable (Non)maskable (Non)maskable	0FFFCh	14
Timer1_A5 (see Note 4)	TA1CCR0 CCIFG (see Note 2)	Maskable	0FFFAh	13
Timer1_A5 (see Note 4)	TA1CCR1 to TA1CCR4 CCIFGs and TA1CTL TAIFG (see Notes 1 and 2)	Maskable	0FFF8h	12
Comparator_A	CMPAIFG	Maskable	0FFF6h	11
Watchdog timer	WDTIFG	Maskable	0FFF4h	10
			0FFF2h	9
			0FFF0h	8
			0FFEEh	7
Timer_A3/Timer0_A3	TACCR0/TA0CCR0 CCIFG (see Note 2)	Maskable	0FFECCh	6
Timer_A3/Timer0_A3	TACCR1/TA0CCR1, TACCR2/TA0CCR2 CCIFGs and TACL1/TA0CTL TAIFG (see Notes 1 and 2)	Maskable	0FFEAh	5
I/O port P1 (eight flags)	P1IFG.0 to P1IFG.7 (see Notes 1 and 2)	Maskable	0FFE8h	4
			0FFE6h	3
			0FFE4h	2
I/O port P2 (eight flags)	P2IFG.0 to P2IFG.7 (see Notes 1 and 2)	Maskable	0FFE2h	1
Basic Timer1	BTIFG	Maskable	0FFE0h	0, lowest

- NOTES: 1. Multiple source flags
 2. Interrupt flags are located in the module.
 3. (Non)maskable: the individual interrupt-enable bit can disable an interrupt event, but the general interrupt-enable cannot.
 4. Implemented in MSP430x415 and MSP430x417 devices only

MSP430x41x MIXED SIGNAL MICROCONTROLLER

SLAS340I – MAY 2001 – REVISED MARCH 2008

special function registers

Most interrupt and module enable bits are collected into the lowest address space. Special function register bits that are not allocated to a functional purpose are not physically present in the device. Simple software access is provided with this arrangement.

interrupt enable 1 and 2

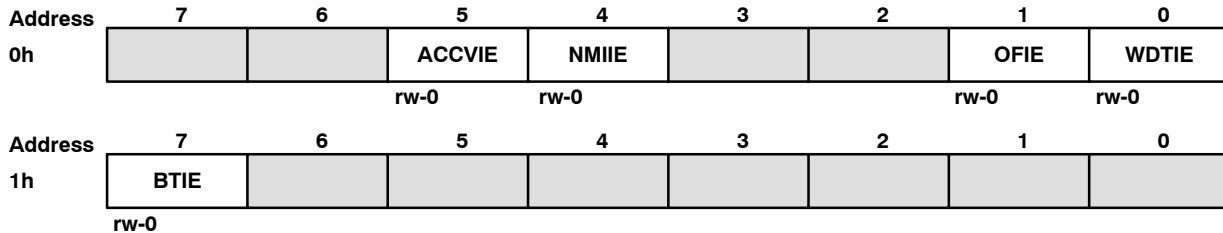

- WDTIE: Watchdog-timer interrupt enable. Inactive if watchdog mode is selected. Active if watchdog timer is configured in interval timer mode.
- OFIE: Oscillator-fault interrupt enable
- NMIIE: Nonmaskable interrupt enable
- ACCVIE: Flash access violation interrupt enable
- BTIE: Basic Timer1 interrupt enable

interrupt flag register 1 and 2

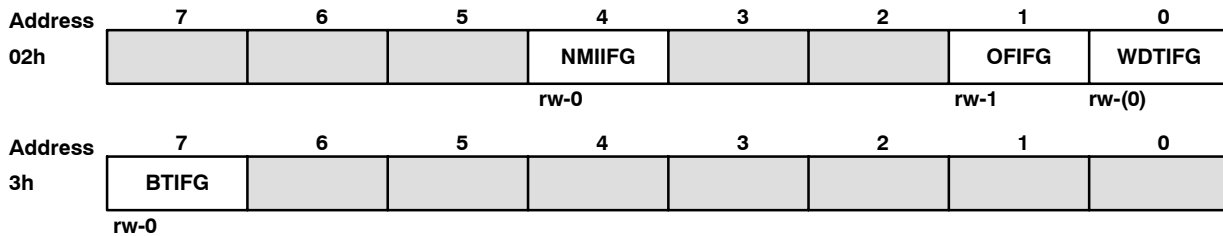

- WDTIFG: Set on watchdog-timer overflow (in watchdog mode) or security key violation. Reset with V_{CC} power-up, or a reset condition at the \overline{RST}/NMI pin in reset mode.
- OFIFG: Flag set on oscillator fault
- NMIIFG: Set via \overline{RST}/NMI pin
- BTIFG: Basic Timer1 interrupt flag

module enable registers 1 and 2

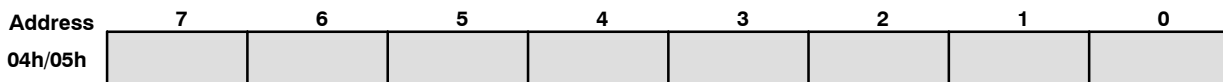

- Legend: **rw-0,1:** Bit Can Be Read and Written. It Is Reset or Set by PUC.
rw-(0,1): Bit Can Be Read and Written. It Is Reset or Set by POR.
 SFR Bit Not Present in Device.



memory organization

		MSP430F412	MSP430F413	MSP430F415	MSP430F417
Memory	Size	4KB	8KB	16KB	32KB
Interrupt vector	Flash	0FFFFh to 0FFE0h	0FFFFh to 0FFE0h	0FFFFh to 0FFE0h	0FFFFh to 0FFE0h
Code memory	Flash	0FFFFh to 0F000h	0FFFFh to 0E000h	0FFFFh to 0C000h	0FFFFh to 08000h
Information memory	Size	256 Byte	256 Byte	256 Byte	256 Byte
	Flash	010FFh to 01000h	010FFh to 01000h	010FFh to 01000h	010FFh to 01000h
Boot memory	Size	1KB	1KB	1KB	1KB
	ROM	0FFFh to 0C00h	0FFFh to 0C00h	0FFFh to 0C00h	0FFFh to 0C00h
RAM	Size	256 Byte 02FFh to 0200h	256 Byte 02FFh to 0200h	512 Byte 03FFh to 0200h	1 KB 05FFh to 0200h
Peripherals	16-bit	01FFh to 0100h	01FFh to 0100h	01FFh to 0100h	01FFh to 0100h
	8-bit	0FFh to 010h	0FFh to 010h	0FFh to 010h	0FFh to 010h
	8-bit SFR	0Fh to 00h	0Fh to 00h	0Fh to 00h	0Fh to 00h

		MSP430C412	MSP430C413
Memory	Size	4KB	8KB
Interrupt vector	ROM	0FFFFh to 0FFE0h	0FFFFh to 0FFE0h
Code memory	ROM	0FFFFh to 0F000h	0FFFFh to 0E000h
Information memory	Size	NA	NA
Boot memory	Size	NA	NA
RAM	Size	256 Byte 02FFh to 0200h	256 Byte 02FFh to 0200h
Peripherals	16-bit	01FFh to 0100h	01FFh to 0100h
	8-bit	0FFh to 010h	0FFh to 010h
	8-bit SFR	0Fh to 00h	0Fh to 00h

bootstrap loader (BSL)

The MSP430 BSL enables users to program the flash memory or RAM using a UART serial interface. Access to the MSP430 memory via the BSL is protected by user-defined password. For complete description of the features of the BSL and its implementation, see the application report *Features of the MSP430 Bootstrap Loader*, literature number SLAA089.

BSL FUNCTION	PM, RTD, RGC PACKAGE PINS
Data Transmit	53 - P1.0
Data Receive	52 - P1.1

MSP430x41x MIXED SIGNAL MICROCONTROLLER

SLAS340I – MAY 2001 – REVISED MARCH 2008

flash memory

The flash memory can be programmed via the JTAG port, the bootstrap loader, or in-system by the CPU. The CPU can perform single-byte and single-word writes to the flash memory. Features of the flash memory include:

- Flash memory has n segments of main memory and two segments of information memory (A and B) of 128 bytes each. Each segment in main memory is 512 bytes in size.
- Segments 0 to n may be erased in one step, or each segment may be individually erased.
- Segments A and B can be erased individually, or as a group with segments 0 to n. Segments A and B are also called *information memory*.
- New devices may have some bytes programmed in the information memory (needed for test during manufacturing). The user should perform an erase of the information memory prior to the first use.

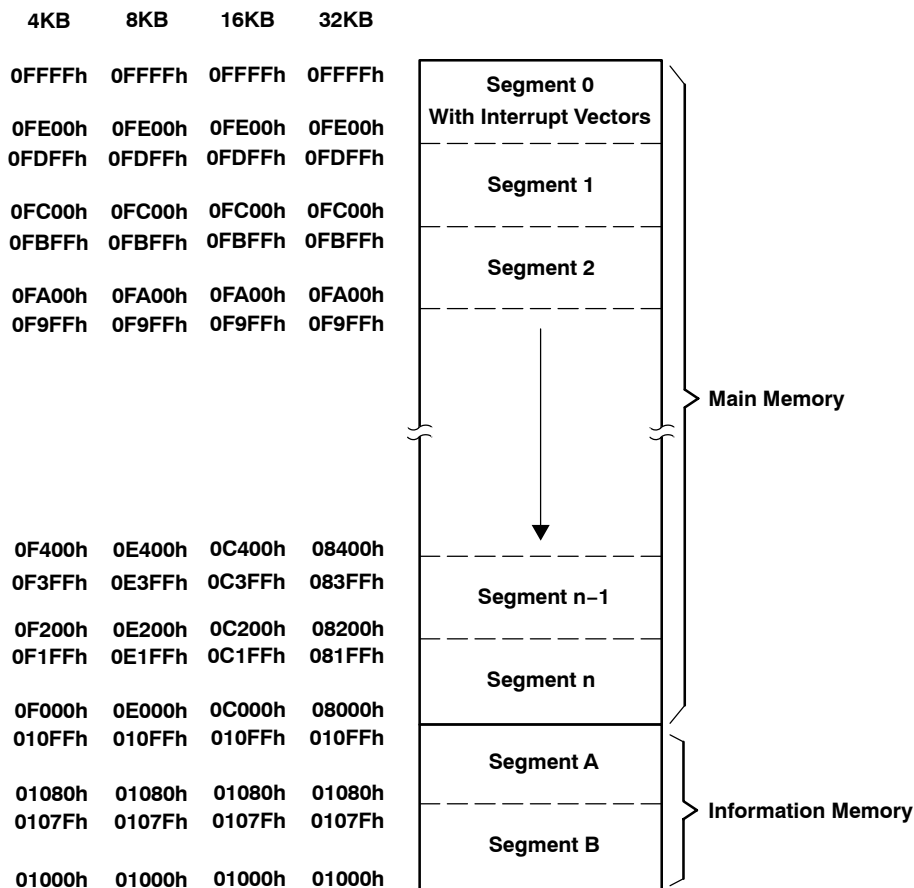

peripherals

Peripherals are connected to the CPU through data, address, and control buses and can be handled using all instructions. For complete module descriptions, see the *MSP430x4xx Family User's Guide*, literature number SLAU056.

oscillator and system clock

The clock system in the MSP430x41x family of devices is supported by the FLL+ module that includes support for a 32768-Hz watch crystal oscillator, an internal digitally-controlled oscillator (DCO), and a high-frequency crystal oscillator. The FLL+ clock module is designed to meet the requirements of both low system cost and low power consumption. The FLL+ features a digital frequency locked loop (FLL) hardware which in conjunction with a digital modulator stabilizes the DCO frequency to a programmable multiple of the watch crystal frequency. The internal DCO provides a fast turn-on clock source and stabilizes in less than 6 μ s. The FLL+ module provides the following clock signals:

- Auxiliary clock (ACLK), sourced from a 32768-Hz watch crystal or a high frequency crystal.
- Main clock (MCLK), the system clock used by the CPU.
- Sub-Main clock (SMCLK), the subsystem clock used by the peripheral modules.
- ACLK/n, the buffered output of ACLK, ACLK/2, ACLK/4, or ACLK/8.

brownout, supply voltage supervisor

The brownout circuit is implemented to provide the proper internal reset signal to the device during power on and power off. The supply voltage supervisor (SVS) circuitry detects if the supply voltage drops below a fixed level or user selectable level (MSP430x415 & MSP430x417 only) and supports both supply voltage supervision (the device is automatically reset) and supply voltage monitoring (SVM, the device is not automatically reset).

The CPU begins code execution after the brownout circuit releases the device reset. However, V_{CC} may not have ramped to $V_{CC(min)}$ at that time. The user must ensure the default FLL+ settings are not changed until V_{CC} reaches $V_{CC(min)}$. If desired, the SVS circuit can be used to determine when V_{CC} reaches $V_{CC(min)}$.

digital I/O

There are six 8-bit I/O ports implemented—ports P1 through P6.

- All individual I/O bits are independently programmable.
- Any combination of input, output, and interrupt conditions is possible.
- Edge-selectable interrupt input capability for all the eight bits of ports P1 and P2.
- Read/write access to port-control registers is supported by all instructions.

Basic Timer1

Basic Timer1 has two independent 8-bit timers that can be cascaded to form a 16-bit timer/counter. Both timers can be read and written by software. Basic Timer1 can be used to generate periodic interrupts and clock for the LCD module.

LCD driver

The LCD driver generates the segment and common signals required to drive an LCD display. The LCD controller has dedicated data memory to hold segment drive information. Common and segment signals are generated as defined by the mode. Static, 2-MUX, 3-MUX, and 4-MUX LCDs are supported by this peripheral.

MSP430x41x MIXED SIGNAL MICROCONTROLLER

SLAS340I – MAY 2001 – REVISED MARCH 2008

watchdog timer (WDT)

The primary function of the WDT module is to perform a controlled system restart after a software problem occurs. If the selected time interval expires, a system reset is generated. If the watchdog function is not needed in an application, the module can be configured as an interval timer and can generate interrupts at selected time intervals.

comparator_A

The primary function of the comparator_A module is to support precision slope analog-to-digital conversions, battery-voltage supervision, and monitoring of external analog signals.

Timer_A3/Timer0_A3

Timer_A3/Timer0_A3 is a 16-bit timer/counter with three capture/compare registers. Timer_A3/Timer0_A3 can support multiple capture/compares, PWM outputs, and interval timing. Timer_A3/Timer0_A3 also has extensive interrupt capabilities. Interrupts may be generated from the counter on overflow conditions and from each of the capture/compare registers.

TIMER_A3/TIMER0_A3 SIGNAL CONNECTIONS					
INPUT PIN NUMBER	DEVICE INPUT SIGNAL	MODULE INPUT NAME	MODULE BLOCK	MODULE OUTPUT SIGNAL	OUTPUT PIN NUMBER
48 - P1.5	TACLK/TA0CLK	TACLK	Timer	NA	
	ACLK	ACLK			
	SMCLK	SMCLK			
48 - P1.5	$\overline{\text{TACLK/TA0CLK}}$	INCLK			
53 - P1.0	TA0/TA0.0	CCI0A	CCR0	TA0/TA0.0	53 - P1.0
52 - P1.1	TA0/TA0.0	CCI0B			
	DV _{SS}	GND			
	DV _{CC}	V _{CC}			
51 - P1.2	TA1/TA0.1	CCI1A	CCR1	TA1/TA0.1	51 - P1.2
	CAOUT (internal)	CCI1B			
	DV _{SS}	GND			
	DV _{CC}	V _{CC}			
45 - P2.0	TA2/TA0.2	CCI2A	CCR2	TA2/TA0.2	45 - P2.0
	ACLK (internal)	CCI2B			
	DV _{SS}	GND			
	DV _{CC}	V _{CC}			



Timer1_A5 (MSP430x415 and MSP430x417 only)

Timer1_A5 is a 16-bit timer/counter with five capture/compare registers. Timer1_A5 can support multiple capture/compares, PWM outputs, and interval timing. Timer1_A5 also has extensive interrupt capabilities. Interrupts may be generated from the counter on overflow conditions and from each of the capture/compare registers.

TIMER1_A5 SIGNAL CONNECTIONS					
INPUT PIN NUMBER	DEVICE INPUT SIGNAL	MODULE INPUT NAME	MODULE BLOCK	MODULE OUTPUT SIGNAL	OUTPUT PIN NUMBER
32 - P2.5	TA1CLK	TACLK	Timer	NA	
	ACLK	ACLK			
	SMCLK	SMCLK			
32 - P2.5	TA1CLK	INCLK			
49 - P1.4	TA1.0	CCI0A	CCR0	TA1.0	49 - P1.4
50 - P1.3	TA1.0	CCI0B			
	DV _{SS}	GND			
	DV _{CC}	V _{CC}			
44 - P2.1	TA1.1	CCI1A	CCR1	TA1.1	44 - P2.1
	CAOUT (internal)	CCI1B			
	DV _{SS}	GND			
	DV _{CC}	V _{CC}			
35 - P2.2	TA1.2	CCI2A	CCR2	TA1.2	35 - P2.2
	Not Connected	CCI2B			
	DV _{SS}	GND			
	DV _{CC}	V _{CC}			
34 - P2.3	TA1.3	CCI3A	CCR3	TA1.3	34 - P2.3
	Not Connected	CCI3B			
	DV _{SS}	GND			
	DV _{CC}	V _{CC}			
33 - P2.4	TA1.4	CCI4A	CCR4	TA1.4	33 - P2.4
	Not Connected	CCI4B			
	DV _{SS}	GND			
	DV _{CC}	V _{CC}			

MSP430x41x MIXED SIGNAL MICROCONTROLLER

SLAS340I – MAY 2001 – REVISED MARCH 2008

peripheral file map

PERIPHERALS WITH WORD ACCESS			
Watchdog	Watchdog Timer control	WDTCTL	0120h
Timer1_A5 (MSP430x415 and MSP430x417 only)	Timer1_A interrupt vector	TA1IV	011Eh
	Timer1_A control	TA1CTL	0180h
	Capture/compare control 0	TA1CCTL0	0182h
	Capture/compare control 1	TA1CCTL1	0184h
	Capture/compare control 2	TA1CCTL2	0186h
	Capture/compare control 3	TA1CCTL3	0188h
	Capture/compare control 4	TA1CCTL4	018Ah
	Reserved		018Ch
	Reserved		018Eh
	Timer1_A register	TA1R	0190h
	Capture/compare register 0	TA1CCR0	0192h
	Capture/compare register 1	TA1CCR1	0194h
	Capture/compare register 2	TA1CCR2	0196h
	Capture/compare register 3	TA1CCR3	0198h
	Capture/compare register 4	TA1CCR4	019Ah
	Reserved		019Ch
Reserved		019Eh	
Timer_A3/Timer0_A3	Timer_A/Timer0_A interrupt vector	TAIV/TA0IV	012Eh
	Timer_A/Timer0_A control	TACTL/TA0CTL	0160h
	Capture/compare control 0	TACCTL0/TA0CCTL0	0162h
	Capture/compare control 1	TACCTL1/TA0CCTL1	0164h
	Capture/compare control 2	TACCTL2/TA0CCTL2	0166h
	Reserved		0168h
	Reserved		016Ah
	Reserved		016Ch
	Reserved		016Eh
	Timer_A/Timer0_A register	TAR/TA0R	0170h
	Capture/compare register 0	TACCR0/TA0CCR0	0172h
	Capture/compare register 1	TACCR1/TA0CCR1	0174h
	Capture/compare register 2	TACCR2/TA0CCR2	0176h
	Reserved		0178h
	Reserved		017Ah
	Reserved		017Ch
Reserved		017Eh	
Flash	Flash control 3	FCTL3	012Ch
	Flash control 2	FCTL2	012Ah
	Flash control 1	FCTL1	0128h



peripheral file map (continued)

PERIPHERALS WITH BYTE ACCESS			
LCD	LCD memory 20	LCDM20	0A4h
	:	:	:
	LCD memory 16	LCDM16	0A0h
	LCD memory 15	LCDM15	09Fh
	:	:	:
	LCD memory 1 LCD control and mode	LCDM1 LCDCTL	091h 090h
Comparator_A	Comparator_A port disable	CAPD	05Bh
	Comparator_A control2	CACTL2	05Ah
	Comparator_A control1	CACTL1	059h
Brownout, SVS	SVS control register	SVSCTL	056h
FLL+ Clock	FLL+ Control1	FLL_CTL1	054h
	FLL+ Control0	FLL_CTL0	053h
	System clock frequency control	SCFQCTL	052h
	System clock frequency integrator	SCFI1	051h
	System clock frequency integrator	SCFI0	050h
Basic Timer1	BT counter2	BTCNT2	047h
	BT counter1	BTCNT1	046h
	BT control	BTCTL	040h
Port P6	Port P6 selection	P6SEL	037h
	Port P6 direction	P6DIR	036h
	Port P6 output	P6OUT	035h
	Port P6 input	P6IN	034h
Port P5	Port P5 selection	P5SEL	033h
	Port P5 direction	P5DIR	032h
	Port P5 output	P5OUT	031h
	Port P5 input	P5IN	030h
Port P4	Port P4 selection	P4SEL	01Fh
	Port P4 direction	P4DIR	01Eh
	Port P4 output	P4OUT	01Dh
	Port P4 input	P4IN	01Ch
Port P3	Port P3 selection	P3SEL	01Bh
	Port P3 direction	P3DIR	01Ah
	Port P3 output	P3OUT	019h
	Port P3 input	P3IN	018h
Port P2	Port P2 selection	P2SEL	02Eh
	Port P2 interrupt enable	P2IE	02Dh
	Port P2 interrupt-edge select	P2IES	02Ch
	Port P2 interrupt flag	P2IFG	02Bh
	Port P2 direction	P2DIR	02Ah
	Port P2 output	P2OUT	029h
	Port P2 input	P2IN	028h

MSP430x41x MIXED SIGNAL MICROCONTROLLER

SLAS340I – MAY 2001 – REVISED MARCH 2008

peripheral file map (continued)

PERIPHERALS WITH BYTE ACCESS (CONTINUED)			
Port P1	Port P1 selection	P1SEL	026h
	Port P1 interrupt enable	P1IE	025h
	Port P1 interrupt-edge select	P1IES	024h
	Port P1 interrupt flag	P1IFG	023h
	Port P1 direction	P1DIR	022h
	Port P1 output	P1OUT	021h
	Port P1 input	P1IN	020h
Special Functions	SFR module enable 2	ME2	005h
	SFR module enable 1	ME1	004h
	SFR interrupt flag2	IFG2	003h
	SFR interrupt flag1	IFG1	002h
	SFR interrupt enable2	IE2	001h
	SFR interrupt enable1	IE1	000h

absolute maximum ratings[†]

Voltage applied at V_{CC} to V_{SS}	-0.3 V to + 4.1 V
Voltage applied to any pin (see Note 1)	-0.3 V to $V_{CC} + 0.3$ V
Diode current at any device terminal	± 2 mA
Storage temperature: Unprogrammed device	-55°C to 150°C
Programmed device	-40°C to 85°C

[†] Stresses beyond those listed under “absolute maximum ratings” may cause permanent damage to the device. These are stress ratings only, and functional operation of the device at these or any other conditions beyond those indicated under “recommended operating conditions” is not implied. Exposure to absolute-maximum-rated conditions for extended periods may affect device reliability.

NOTES: 1. All voltages referenced to V_{SS} . The JTAG fuse-blow voltage, V_{FB} , is allowed to exceed the absolute maximum rating. The voltage is applied to the TDI/TCLK pin when blowing the JTAG fuse.



recommended operating conditions

PARAMETER		MIN	NOM	MAX	UNITS	
Supply voltage during program execution, V_{CC} ($AV_{CC} = DV_{CC} = V_{CC}$) (see Note 1)	MSP430x41x	1.8		3.6	V	
Supply voltage during program execution, SVS enabled and PORON = 1, V_{CC} ($AV_{CC} = DV_{CC} = V_{CC}$) (see Note 1 and Note 2)	MSP430x412/413	2.2		3.6	V	
	MSP430x415/417	2.0		3.6		
Supply voltage during programming of flash memory, V_{CC} ($AV_{CC} = DV_{CC} = V_{CC}$)	MSP430F41x	2.7		3.6	V	
Supply voltage, V_{SS} ($AV_{SS1/2} = DV_{SS} = V_{SS}$)		0		0	V	
Operating free-air temperature range, T_A	MSP430x41x	-40		85	°C	
LFXT1 crystal frequency, $f_{(LFXT1)}$ (see Note 3)	LF selected, XTS_FLL=0	Watch crystal		32768	Hz	
	XT1 selected, XTS_FLL=1	Ceramic resonator		450	8000	kHz
	XT1 selected, XTS_FLL=1	Crystal		1000	8000	
Processor frequency (signal MCLK), $f_{(System)}$	$V_{CC} = 1.8\text{ V}$	DC		4.15	MHz	
	$V_{CC} = 3.6\text{ V}$	DC		8		

- NOTES: 1. It is recommended to power AV_{CC} and DV_{CC} from the same source. A maximum difference of 0.3 V between AV_{CC} and DV_{CC} can be tolerated during power up and operation.
2. The minimum operating supply voltage is defined according to the trip point where POR is going active by decreasing supply voltage. POR is going inactive when the supply voltage is raised above minimum supply voltage plus the hysteresis of the SVS circuitry.
3. In LF mode, the LFXT1 oscillator requires a watch crystal. In XT1 mode, LFXT1 accepts a ceramic resonator or a crystal.

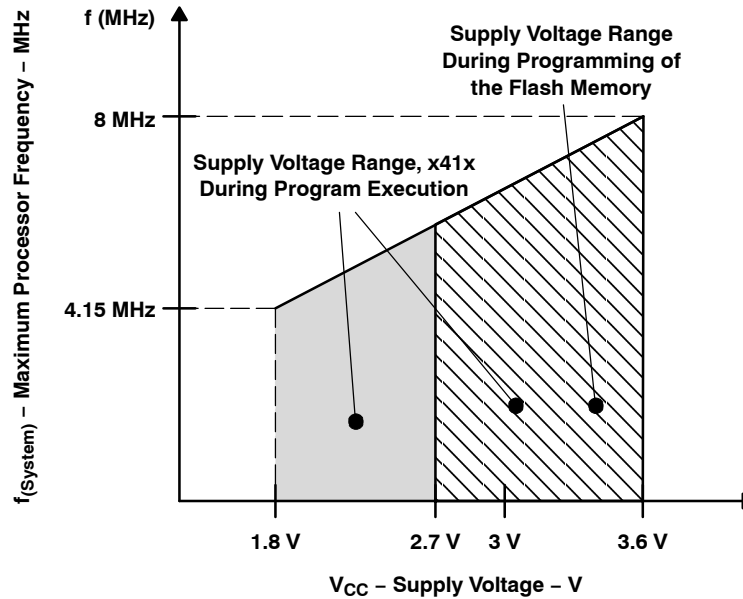

Figure 1. Frequency vs Supply Voltage

MSP430x41x MIXED SIGNAL MICROCONTROLLER

SLAS340I – MAY 2001 – REVISED MARCH 2008

electrical characteristics over recommended operating free-air temperature (unless otherwise noted)

supply current into $AV_{CC} + DV_{CC}$ excluding external current (see Note 1)

PARAMETER		TEST CONDITIONS	V_{CC}	MIN	TYP	MAX	UNIT
$I_{(AM)}$	Active mode, $f_{(MCLK)} = f_{(SMCLK)} = f_{(DCO)} = 1 \text{ MHz}$, $f_{(ACLK)} = 32,768 \text{ Hz}$, $XTS_FLL = 0$ (F41x: Program executes in flash)	$T_A = -40^\circ\text{C}$ to 85°C	2.2 V		160	200	μA
			3 V		240	300	
			2.2 V		200	250	
			3 V		300	350	
$I_{(LPM0)}$	Low-power mode (LPM0) $f_{(MCLK)} = f_{(SMCLK)} = f_{(DCO)} = 0.5 \text{ MHz}$, $f_{(ACLK)} = 32,768 \text{ Hz}$, $XTS_FLL = 0$ $FN_8=FN_4=FN_3=FN_2=0$ (see Note 3)	$T_A = -40^\circ\text{C}$ to 85°C	2.2 V		32	45	μA
			3 V		55	70	
	Low-power mode (LPM0) $f_{(MCLK)} = f_{(SMCLK)} = f_{(DCO)} = 1 \text{ MHz}$, $f_{(ACLK)} = 32,768 \text{ Hz}$, $XTS_FLL = 0$ $FN_8=FN_4=FN_3=FN_2=0$ (see Note 3)		2.2 V		57	70	
			3 V		92	100	
$I_{(LPM2)}$	Low-power mode (LPM2) (see Note 3)	$T_A = -40^\circ\text{C}$ to 85°C	2.2 V		11	14	μA
			3 V		17	22	
$I_{(LPM3)}$	Low-power mode (LPM3) (see Note 2 and Note 3)	$T_A = -40^\circ\text{C}$	2.2 V		0.95	1.4	μA
		$T_A = -10^\circ\text{C}$			0.8	1.3	
		$T_A = 25^\circ\text{C}$			0.7	1.2	
		$T_A = 60^\circ\text{C}$			0.95	1.4	
		$T_A = 85^\circ\text{C}$			1.6	2.3	
		$T_A = -40^\circ\text{C}$	3 V		1.1	1.7	
		$T_A = -10^\circ\text{C}$			1.0	1.6	
		$T_A = 25^\circ\text{C}$			0.9	1.5	
		$T_A = 60^\circ\text{C}$			1.1	1.7	
		$T_A = 85^\circ\text{C}$			2.0	2.6	
$I_{(LPM4)}$	Low-power mode (LPM4) (see Note 3)	$T_A = -40^\circ\text{C}$	2.2 V/3 V		0.1	0.5	μA
		$T_A = 25^\circ\text{C}$			0.1	0.5	
		$T_A = 85^\circ\text{C}$			0.8	2.5	

NOTES: 1. All inputs are tied to 0 V or V_{CC} . Outputs do not source or sink any current. The current consumption is measured with active Basic Timer1 and LCD (ACLK selected).

The current consumption of the Comparator_A and the SVS module are specified in the respective sections.

2. The LPM3 currents are characterized with a KDS Daishinku DT-38 (6 pF) crystal.

3. Current for brownout included.

current consumption of active mode versus system frequency

$$I_{(AM)} = I_{(AM)} [1 \text{ MHz}] \times f_{(\text{System})} [\text{MHz}]$$

current consumption of active mode versus supply voltage

$$I_{(AM)} = I_{(AM)} [3 \text{ V}] + 140 \mu\text{A/V} \times (V_{CC} - 3 \text{ V})$$



electrical characteristics over recommended operating free-air temperature (unless otherwise noted) (continued)

Schmitt-trigger inputs – ports P1, P2, P3, P4, P5, and P6

PARAMETER		V _{CC}	MIN	MAX	UNIT
V _{IT+}	Positive-going input threshold voltage	2.2 V	1.1	1.5	V
		3 V	1.5	1.9	
V _{IT-}	Negative-going input threshold voltage	2.2 V	0.4	0.9	V
		3 V	0.9	1.3	
V _{hys}	Input voltage hysteresis (V _{IT+} – V _{IT-})	2.2 V	0.3	1.1	V
		3 V	0.45	1	

standard inputs – RST/NMI, JTAG (TCK, TMS, TDI/TCLK, TDO/TDI)

PARAMETER		V _{CC}	MIN	MAX	UNIT
V _{IL}	Low-level input voltage	2.2 V/3 V	V _{SS}	V _{SS} +0.6	V
V _{IH}	High-level input voltage		0.8×V _{CC}	V _{CC}	V

inputs Px.x, TA_x/TA_x.x

PARAMETER		TEST CONDITIONS	V _{CC}	MIN	MAX	UNIT
t _(int)	External interrupt timing	Port P1, P2: P1.x to P2.x, External trigger signal for the interrupt flag (see Note 1)	2.2 V/3 V	1.5		cycle
			2.2 V	62		ns
			3 V	50		
t _(cap)	Timer_A, capture timing	TA _x /TA _x .y	2.2 V	62		ns
			3 V	50		
f _(TAext)	Timer_A clock frequency externally applied to pin	TACLK/TA _x CLK, INCLK t _(H) = t _(L)	2.2 V		8	MHz
			3 V		10	
f _(TAint)	Timer_A clock frequency	SMCLK or ACLK signal selected	2.2 V		8	MHz
			3 V		10	

NOTES: 1. The external signal sets the interrupt flag every time the minimum t_(int) cycle and time parameters are met. It may be set even with trigger signals shorter than t_(int). Both the cycle and timing specifications must be met to ensure the flag is set. t_(int) is measured in MCLK cycles.

leakage current (see Note 1)

PARAMETER		TEST CONDITIONS	V _{CC}	MIN	MAX	UNIT
I _{lkg} (P1.x)	Leakage current	Port P1	2.2 V/3 V		±50	nA
I _{lkg} (P2.x)		Port P2			±50	
I _{lkg} (P3.x)		Port P3			±50	
I _{lkg} (P4.x)		Port P4			±50	
I _{lkg} (P5.x)		Port P5			±50	
I _{lkg} (P6.x)		Port P6			±50	

NOTES: 1. The leakage current is measured with V_{SS} or V_{CC} applied to the corresponding pin(s), unless otherwise noted.
2. The port pin must be selected as an input.

MSP430x41x MIXED SIGNAL MICROCONTROLLER

SLAS340I – MAY 2001 – REVISED MARCH 2008

electrical characteristics over recommended operating free-air temperature (unless otherwise noted) (continued)

outputs – ports P1, P2, P3, P4, P5, and P6

PARAMETER		TEST CONDITIONS	V _{CC}	MIN	MAX	UNIT
V _{OH}	High-level output voltage	I _{OH(max)} = -1.5 mA, See Note 1	2.2 V	V _{CC} -0.25	V _{CC}	V
		I _{OH(max)} = -6 mA, See Note 2	2.2 V	V _{CC} -0.6	V _{CC}	
		I _{OH(max)} = -1.5 mA, See Note 1	3 V	V _{CC} -0.25	V _{CC}	
		I _{OH(max)} = -6 mA, See Note 2	3 V	V _{CC} -0.6	V _{CC}	
V _{OL}	Low-level output voltage	I _{OL(max)} = 1.5 mA, See Note 1	2.2 V	V _{SS}	V _{SS} +0.25	V
		I _{OL(max)} = 6 mA, See Note 2	2.2 V	V _{SS}	V _{SS} +0.6	
		I _{OL(max)} = 1.5 mA, See Note 1	3 V	V _{SS}	V _{SS} +0.25	
		I _{OL(max)} = 6 mA, See Note 2	3 V	V _{SS}	V _{SS} +0.6	

- NOTES: 1. The maximum total current, I_{OH(max)} and I_{OL(max)}, for all outputs combined, should not exceed ±12 mA to satisfy the maximum specified voltage drop.
 2. The maximum total current, I_{OH(max)} and I_{OL(max)}, for all outputs combined, should not exceed ±24 mA to satisfy the maximum specified voltage drop.

output frequency

PARAMETER		TEST CONDITIONS	MIN	TYP	MAX	UNIT
f _{Px.y}	(1 ≤ x ≤ 6, 0 ≤ y ≤ 7)	C _L = 20 pF, I _L = ± 1.5mA	V _{CC} = 2.2 V	DC	10	MHz
			V _{CC} = 3 V	DC	12	
f _{ACLK} , f _{MCLK} , f _{SMCLK}	P1.1/TA0/MCLK, P1.5/TACLK/ACLK	C _L = 20 pF	V _{CC} = 2.2 V		8	MHz
			V _{CC} = 3 V		12	
t _{Xdc}	Duty cycle of output frequency	P1.5/TACLK/ACLK, C _L = 20 pF V _{CC} = 2.2 V / 3 V	f _{ACLK} = f _{LFXT1} = f _{XT1}	40%	60%	
			f _{ACLK} = f _{LFXT1} = f _{LF}	30%	70%	
			f _{ACLK} = f _{LFXT1/n}	50%		
		P1.1/TA0/MCLK, C _L = 20 pF, V _{CC} = 2.2 V / 3 V	f _{MCLK} = f _{LFXT1/n}	50%– 15 ns	50%	
f _{MCLK} = f _{DCOCLK}	50%– 15 ns		50%	50%+ 15 ns		



electrical characteristics over recommended operating free-air temperature (unless otherwise noted) (continued)

MSP430x412, MSP430x413 outputs – ports P1, P2, P3, P4, P5, and P6 (see Note A)

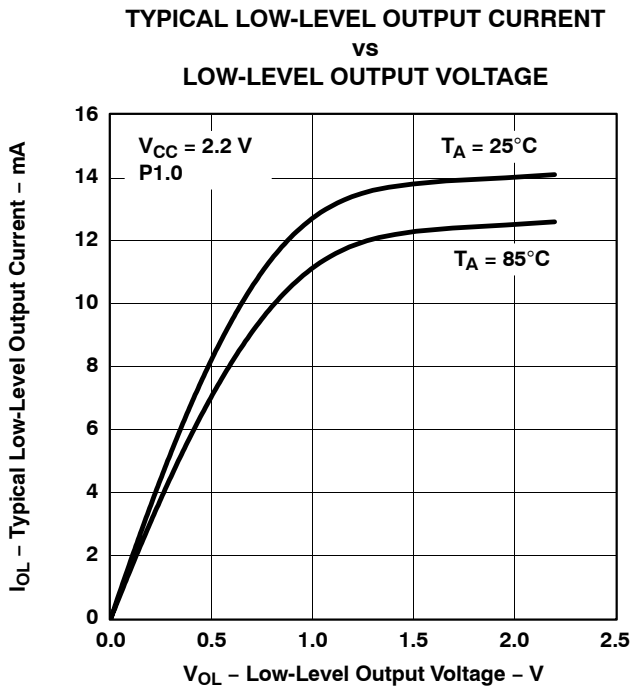

Figure 2

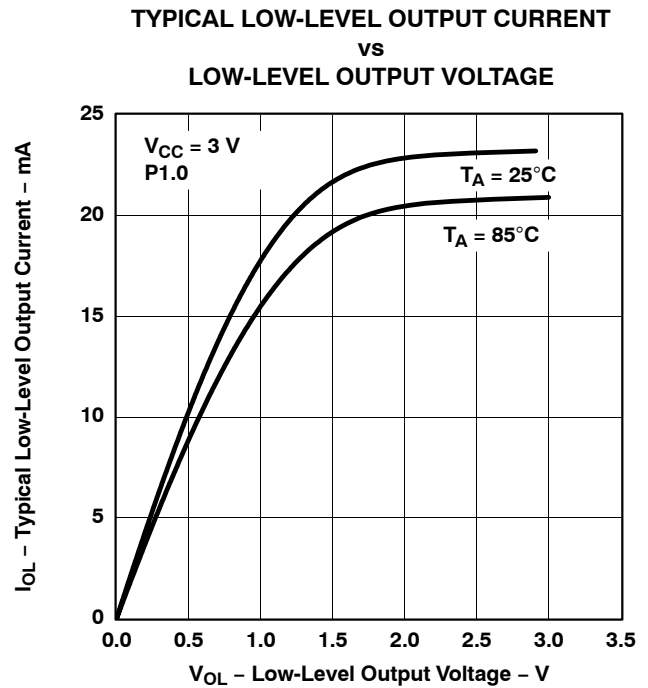

Figure 3

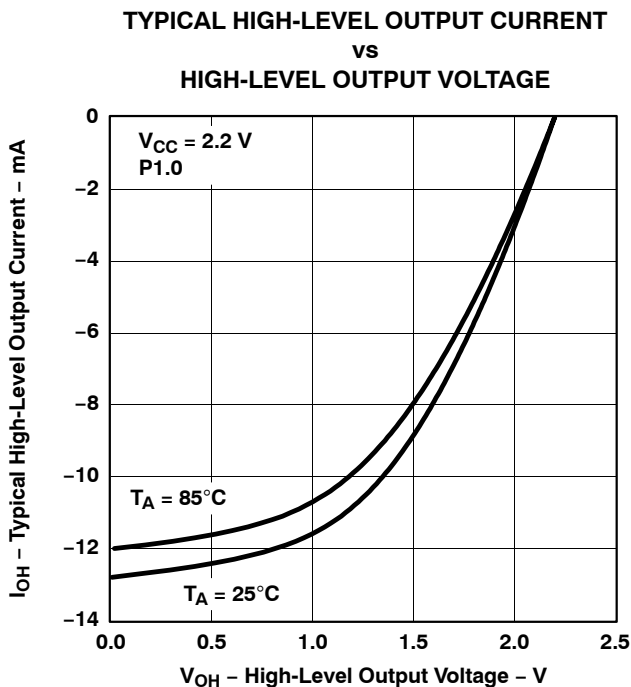

Figure 4

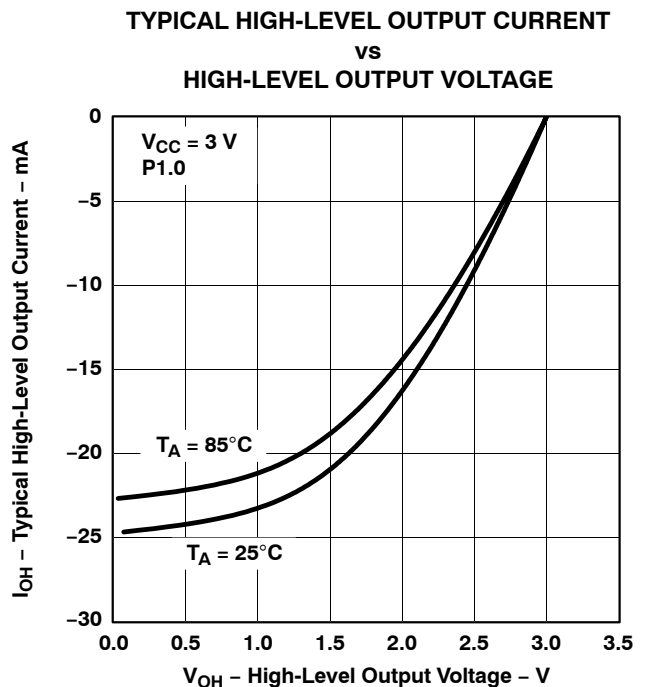

Figure 5

NOTE A: One output loaded at a time

MSP430x41x MIXED SIGNAL MICROCONTROLLER

SLAS340I – MAY 2001 – REVISED MARCH 2008

electrical characteristics over recommended operating free-air temperature (unless otherwise noted) (continued)

MSP430x415, MSP430x417 outputs – ports P1, P2, P3, P4, P5, and P6 (see Note A)

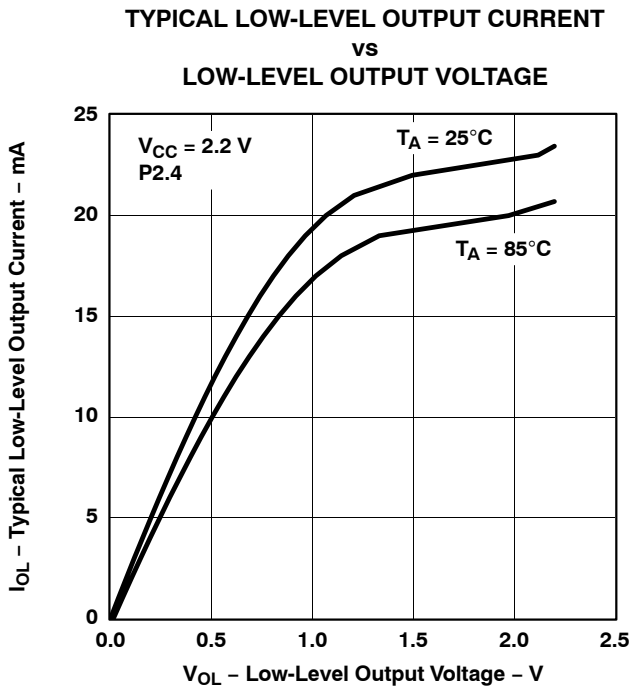

Figure 6

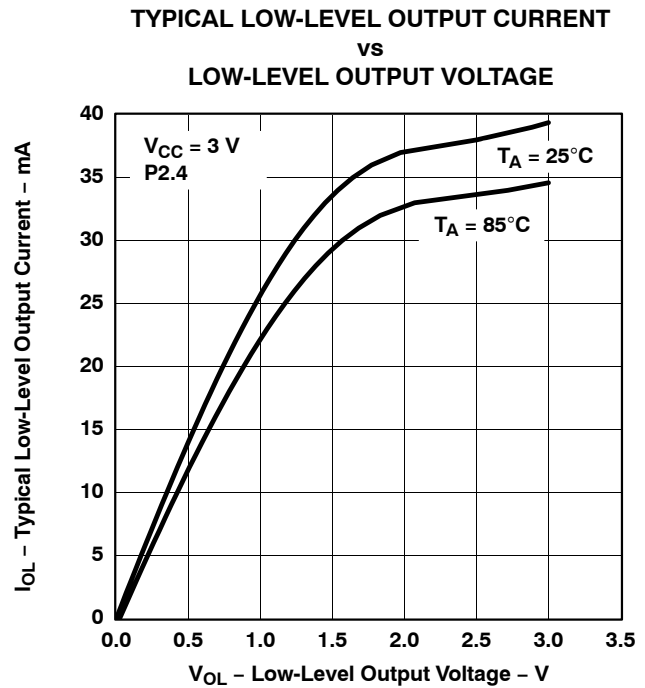

Figure 7

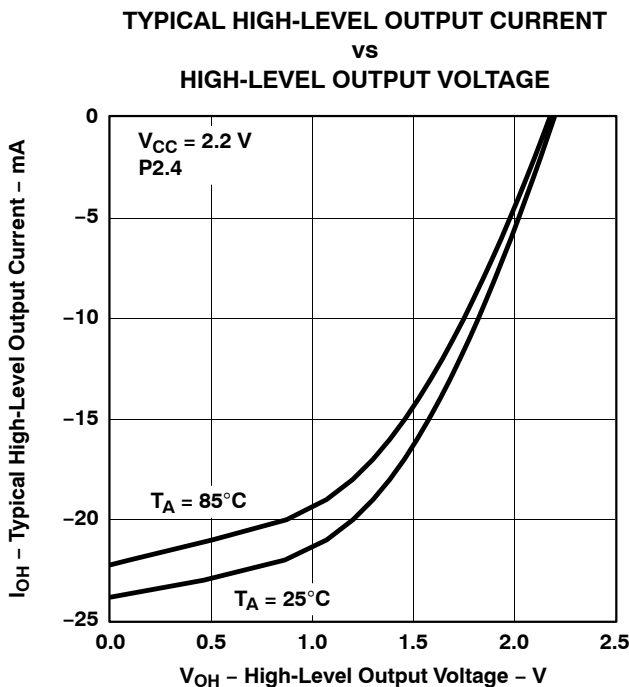

Figure 8

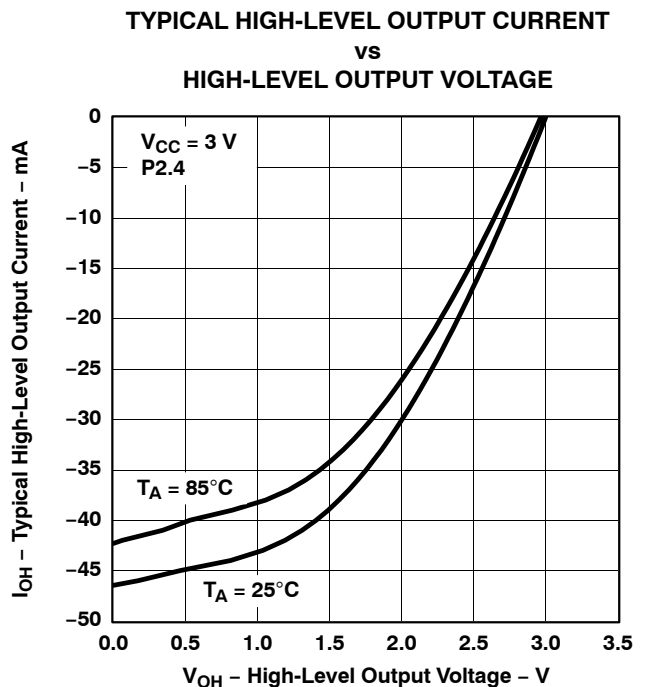

Figure 9

NOTE B: One output loaded at a time

electrical characteristics over recommended operating free-air temperature (unless otherwise noted) (continued)

wake-up LPM3

PARAMETER		TEST CONDITIONS		MIN	MAX	UNIT
$t_{d(LPM3)}$	Delay time	f = 1 MHz	$V_{CC} = 2.2 V/3 V$		6	μs
		f = 2 MHz		6		
		f = 3 MHz		6		

RAM (see Note 1)

PARAMETER	TEST CONDITIONS	MIN	MAX	UNIT
V_{RAMh}	CPU halted (see Note 1)	1.6		V

NOTE 1: This parameter defines the minimum supply voltage when the data in the program memory RAM remain unchanged. No program execution should take place during this supply voltage condition.

LCD

PARAMETER		TEST CONDITIONS		MIN	TYP	MAX	UNIT
$V_{(33)}$	Analog voltage	Voltage at P5.7/R33	$V_{CC} = 3 V$	2.5		$V_{CC} + 0.2$	V
$V_{(23)}$		Voltage at P5.6/R23		$(V_{33} - V_{03}) \times 2/3 + V_{03}$			
$V_{(13)}$		Voltage at P5.5/R13		$(V_{(33)} - V_{(03)}) \times 1/3 + V_{(03)}$			
$V_{(33)} - V_{(03)}$		Voltage at R33/R03		2.5	$V_{CC} + 0.2$		
$I_{(R03)}$	Input leakage	$R03 = V_{SS}$	No load at all segment and common lines, $V_{CC} = 3 V$			± 20	nA
$I_{(R13)}$		$P5.5/R13 = V_{CC}/3$			± 20		
$I_{(R23)}$		$P5.6/R23 = 2 \times V_{CC}/3$			± 20		
$V_{(Sxx0)}$	Segment line voltage	$I_{(Sxx)} = -3 \mu A,$	$V_{CC} = 3 V$	$V_{(03)}$		$V_{(03)} - 0.1$	V
$V_{(Sxx1)}$				$V_{(13)}$	$V_{(13)} - 0.1$		
$V_{(Sxx2)}$				$V_{(23)}$	$V_{(23)} - 0.1$		
$V_{(Sxx3)}$				$V_{(33)}$	$V_{(33)} + 0.1$		

MSP430x41x MIXED SIGNAL MICROCONTROLLER

SLAS340I – MAY 2001 – REVISED MARCH 2008

electrical characteristics over recommended operating free-air temperature (unless otherwise noted) (continued)

Comparator_A (see Note 1)

PARAMETER	TEST CONDITIONS	V _{CC}	MIN	TYP	MAX	UNIT
I _(CC)	CAON = 1, CARSEL = 0, CAREF = 0	2.2 V		25	40	μA
		3 V		45	60	
I _(Ref ladder/RefDiode)	CAON = 1, CARSEL = 0, CAREF = 1/2/3, No load at P1.6/CA0 and P1.7/CA1	2.2 V		30	50	μA
		3 V		45	71	
V _(Ref025)	$\frac{\text{Voltage @ } 0.25 V_{CC} \text{ node}}{V_{CC}}$ PCA0 = 1, CARSEL = 1, CAREF = 1, No load at P1.6/CA0 and P1.7/CA1	2.2 V / 3 V	0.23	0.24	0.25	
V _(Ref050)	$\frac{\text{Voltage @ } 0.5 V_{CC} \text{ node}}{V_{CC}}$ PCA0 = 1, CARSEL = 1, CAREF = 2, No load at P1.6/CA0 and P1.7/CA1	2.2V / 3 V	0.47	0.48	0.50	
V _(RefVT)	See Figure 10 and Figure 11 PCA0 = 1, CARSEL = 1, CAREF = 3, No load at P1.6/CA0 and P1.7/CA1; T _A = 85°C	2.2 V	390	480	540	mV
		3 V	400	490	550	
V _(IC)	Common-mode input voltage range CAON = 1	2.2 V/3 V	0		V _{CC} -1.0	V
V _(offset)	Offset voltage See Note 2	2.2 V/3 V	-30		30	mV
V _(hys)	Input hysteresis CAON = 1	2.2 V/3 V	0	0.7	1.4	mV
t _(response LH)	T _A = 25°C, Overdrive 10 mV, Without filter: CAF = 0	2.2 V	160	210	300	ns
		3 V	80	150	240	
	T _A = 25°C Overdrive 10 mV, With filter: CAF = 1	2.2 V	1.4	1.9	3.4	μs
		3 V	0.9	1.5	2.6	
t _(response HL)	T _A = 25°C Overdrive 10 mV, Without filter: CAF = 0	2.2 V	130	210	300	ns
		3 V	80	150	240	
	T _A = 25°C, Overdrive 10 mV, With filter: CAF = 1	2.2 V	1.4	1.9	3.4	μs
		3 V	0.9	1.5	2.6	

- NOTES: 1. The leakage current for the Comparator_A terminals is identical to I_{lkg(Px.x)} specification.
 2. The input offset voltage can be cancelled by using the CAEX bit to invert the Comparator_A inputs on successive measurements. The two successive measurements are then summed together.

electrical characteristics over recommended operating free-air temperature (unless otherwise noted) (continued)

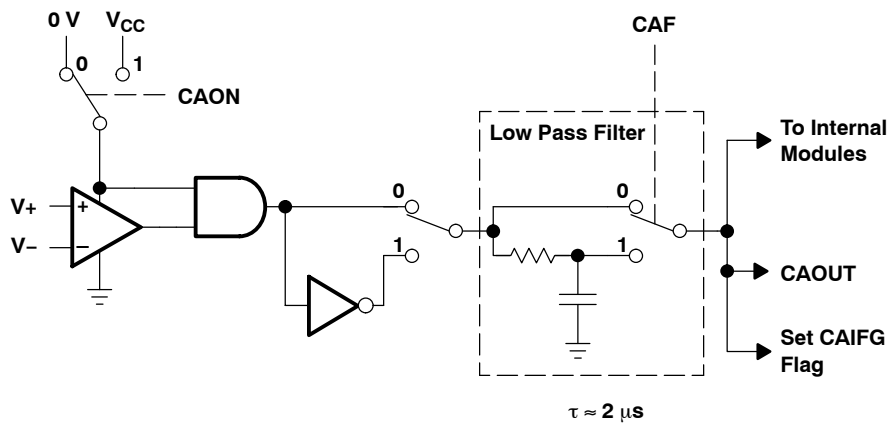
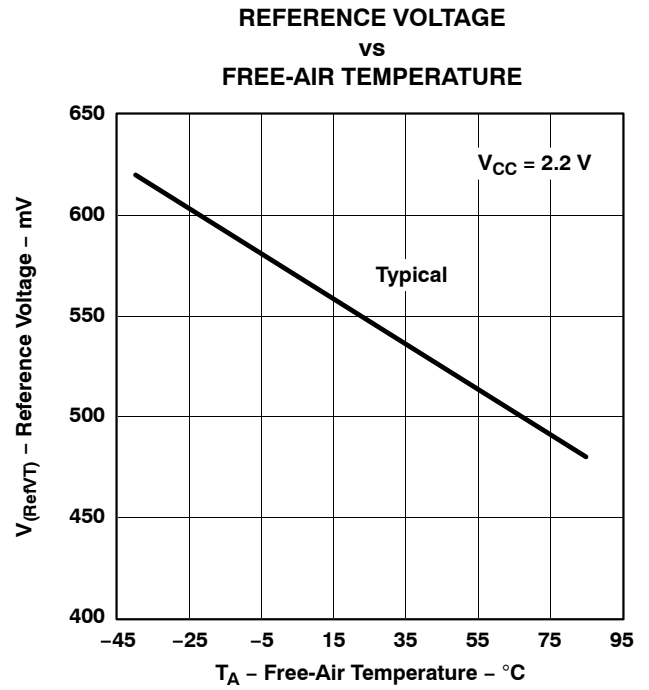
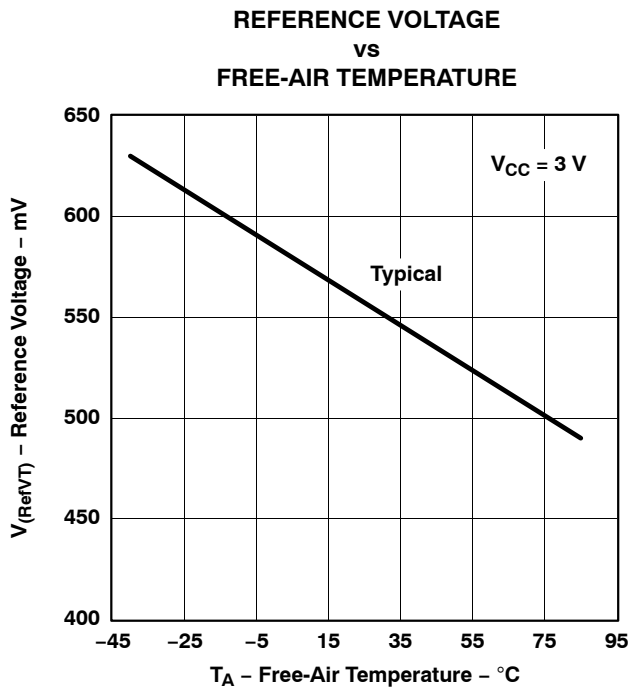

Figure 12. Comparator_A Module Block Diagram

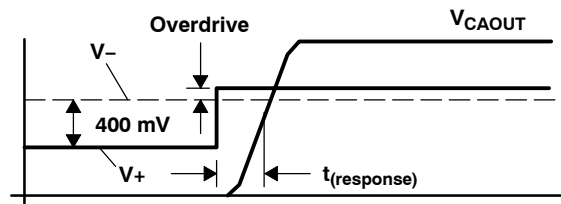

Figure 13. Overdrive Definition

MSP430x41x MIXED SIGNAL MICROCONTROLLER

SLAS340I – MAY 2001 – REVISED MARCH 2008

electrical characteristics over recommended operating free-air temperature (unless otherwise noted) (continued)

POR brownout, reset (see Notes 1 and 2)

PARAMETER	TEST CONDITIONS	MIN	TYP	MAX	UNIT
$t_d(\text{BOR})$				2000	μs
$V_{\text{CC}(\text{start})}$	$dV_{\text{CC}}/dt \leq 3 \text{ V/s}$ (see Figure 14)		$0.7 \times V_{(\text{B_IT-})}$		V
$V_{(\text{B_IT-})}$	$dV_{\text{CC}}/dt \leq 3 \text{ V/s}$ (see Figure 14, Figure 15, Figure 16)			1.71	V
$V_{\text{hys}(\text{B_IT-})}$	$dV_{\text{CC}}/dt \leq 3 \text{ V/s}$ (see Figure 14)	70	130	180	mV
$t_{(\text{reset})}$	Pulse length needed at $\overline{\text{RST}}/\text{NMI}$ pin to accepted reset internally, $V_{\text{CC}} = 2.2 \text{ V}/3 \text{ V}$	2			μs

- NOTES: 1. The current consumption of the brownout module is already included in the I_{CC} current consumption data. The voltage level $V_{(\text{B_IT-})} + V_{\text{hys}(\text{B_IT-})}$ is $\leq 1.8 \text{ V}$.
2. During power up, the CPU begins code execution following a period of $t_d(\text{BOR})$ after $V_{\text{CC}} = V_{(\text{B_IT-})} + V_{\text{hys}(\text{B_IT-})}$. The default FLL+ settings must not be changed until $V_{\text{CC}} \geq V_{\text{CC}(\text{min})}$. See the *MSP430x4xx Family User's Guide* (SLAU056) for more information on the brownout/SVS circuit.

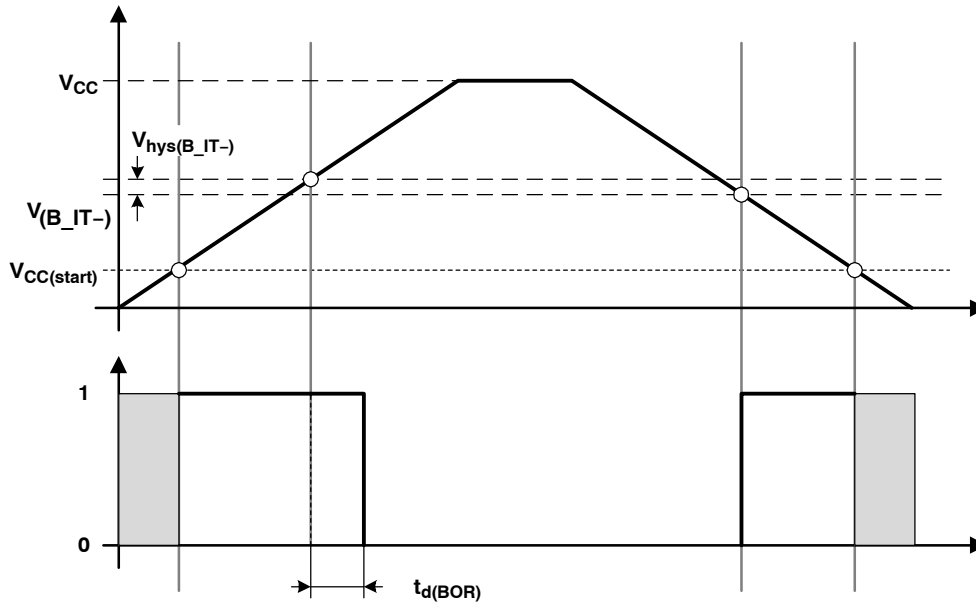

Figure 14. POR/Brownout Reset (BOR) vs Supply Voltage

electrical characteristics over recommended operating free-air temperature (unless otherwise noted) (continued)

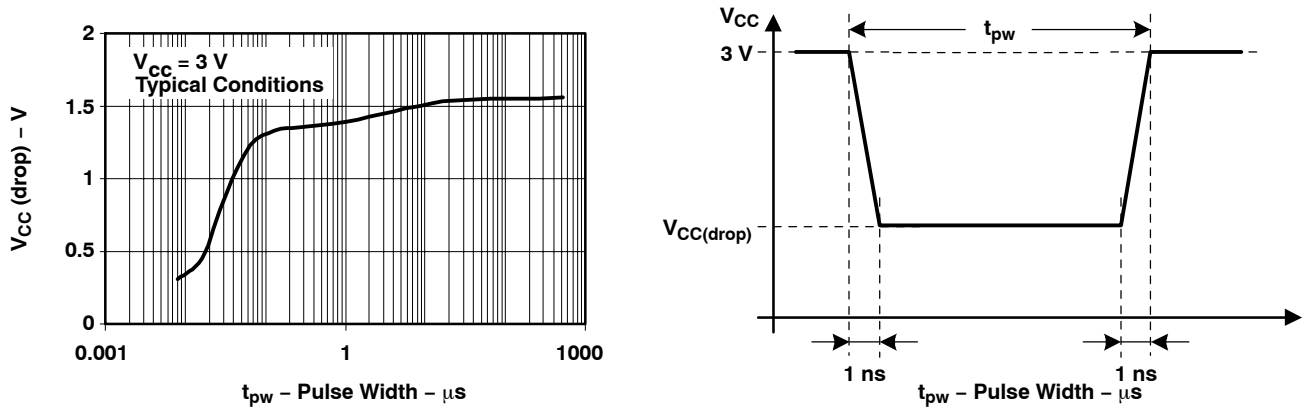

Figure 15. $V_{CC(drop)}$ Level With a Square Voltage Drop to Generate a POR/Brownout Signal

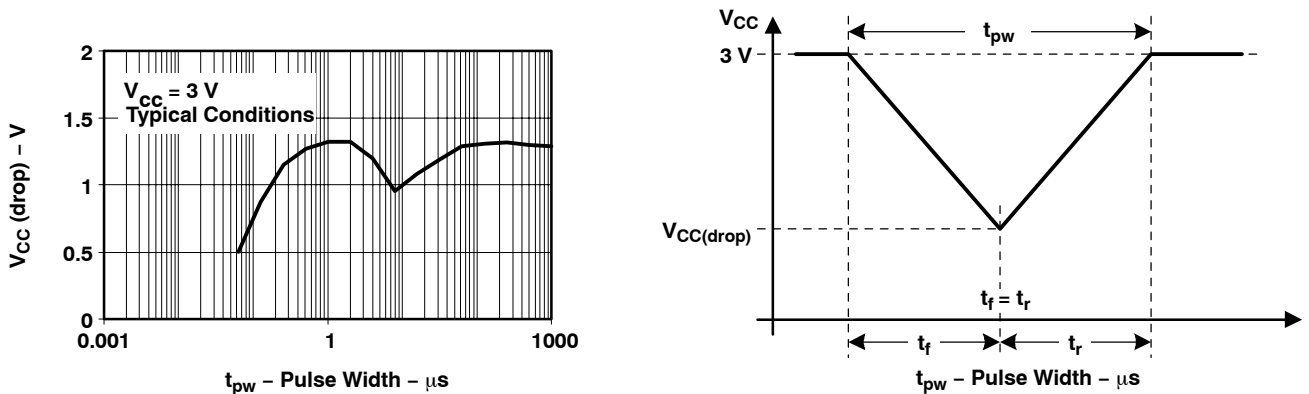

Figure 16. $V_{CC(drop)}$ Level With a Triangle Voltage Drop to Generate a POR/Brownout Signal

SVS (supply voltage supervisor/monitor) (MSP430x412, MSP430x413 only) (see Notes 1 and 2)

PARAMETER	TEST CONDITIONS	MIN	TYP	MAX	UNIT
$t_d(SVSR)$	$dV_{CC}/dt > 30 \text{ V/ms}$ (see Note 2)	5		150	μs
	$dV_{CC}/dt \leq 30 \text{ V/ms}$ (see Note 2)			2000	μs
$t_d(SV\text{Son})$	SVSon, switch from 0 to 1, $V_{CC} = 3 \text{ V}$ (see Note 2)	20		150	μs
$V(SV\text{sstart})$	$dV_{CC}/dt \leq 3 \text{ V/s}$ (see Figure 17)		1.55	1.7	V
$V(SV\text{sIT-})$	$dV_{CC}/dt \leq 3 \text{ V/s}$ (see Figure 17)	1.8	1.95	2.2	V
$V_{hys}(SV\text{sIT-})$	$dV_{CC}/dt \leq 3 \text{ V/s}$ (see Figure 17)	70	100	155	mV
$I_{CC}(SV\text{s})$ (see Note 1)	$VLD \neq 0$ (VLD bits are in SVSCTL register), $V_{CC} = 2.2 \text{ V}/3 \text{ V}$		10	15	μA

- NOTES: 1. The current consumption of the SVS module is not included in the I_{CC} current consumption data.
2. The SVS is not active at power up.

MSP430x41x MIXED SIGNAL MICROCONTROLLER

SLAS340I – MAY 2001 – REVISED MARCH 2008

electrical characteristics over recommended operating free-air temperature (unless otherwise noted) (continued)

SVS (supply voltage supervisor/monitor) (MSP430x415, MSP430x417 only) (see Notes 1 and 2)

PARAMETER	TEST CONDITIONS	MIN	NOM	MAX	UNIT	
$t_d(\text{SVSR})$	$dV_{CC}/dt > 30 \text{ V/ms}$ (see Figure 17)	5		150	μs	
	$dV_{CC}/dt \leq 30 \text{ V/ms}$			2000		
$t_d(\text{SVSon})$	SVSon, switch from VLD=0 to VLD \neq 0, $V_{CC} = 3 \text{ V}$	20		150	μs	
t_{settle}	VLD \neq 0 [†]			12	μs	
$V_{\text{I}}(\text{SVSstart})$	VLD \neq 0, $V_{CC}/dt \leq 3 \text{ V/s}$ (see Figure 17)		1.55	1.7	V	
$V_{\text{hys}}(\text{SVS_IT-})$	$V_{CC}/dt \leq 3 \text{ V/s}$ (see Figure 17)	VLD = 1	70	120	155	mV
		VLD = 2 to 14	$V_{\text{I}}(\text{SVS_IT-}) \times 0.004$		$V_{\text{I}}(\text{SVS_IT-}) \times 0.008$	
	$V_{CC}/dt \leq 3 \text{ V/s}$ (see Figure 17), External voltage applied on SVSIN	VLD = 15	4.4		10.4	mV
$V_{\text{I}}(\text{SVS_IT-})$	$V_{CC}/dt \leq 3 \text{ V/s}$ (see Figure 17)	VLD = 1	1.8	1.9	2.05	V
		VLD = 2	1.94	2.1	2.25	
		VLD = 3	2.05	2.2	2.37	
		VLD = 4	2.14	2.3	2.48	
		VLD = 5	2.24	2.4	2.6	
		VLD = 6	2.33	2.5	2.71	
		VLD = 7	2.46	2.65	2.86	
		VLD = 8	2.58	2.8	3	
		VLD = 9	2.69	2.9	3.13	
		VLD = 10	2.83	3.05	3.29	
		VLD = 11	2.94	3.2	3.42	
		VLD = 12	3.11	3.35	3.61 [†]	
		VLD = 13	3.24	3.5	3.76 [†]	
		VLD = 14	3.43	3.7 [†]	3.99 [†]	
	$V_{CC}/dt \leq 3 \text{ V/s}$ (see Figure 17), External voltage applied on SVSIN	VLD = 15	1.1	1.2	1.3	
$I_{CC}(\text{SVS})$ (see Note 1)	VLD \neq 0, $V_{CC} = 2.2 \text{ V}/3 \text{ V}$		10	15	μA	

[†] The recommended operating voltage range is limited to 3.6 V.

[‡] t_{settle} is the settling time that the comparator o/p needs to have a stable level after VLD is switched VLD \neq 0 to a different VLD value somewhere between 2 and 15. The overdrive is assumed to be $> 50 \text{ mV}$.

NOTES: 1. The current consumption of the SVS module is not included in the I_{CC} current consumption data.
2. The SVS is not active at power up.

electrical characteristics over recommended operating free-air temperature (unless otherwise noted) (continued)

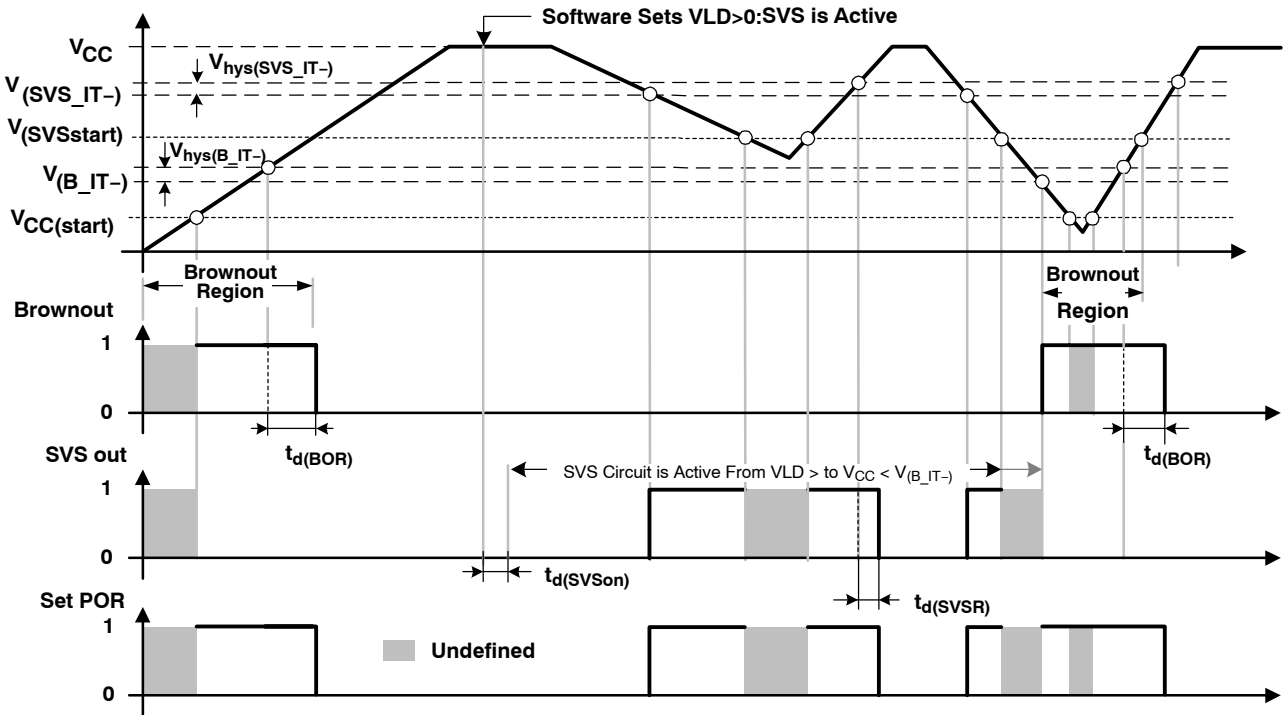

Figure 17. SVS Reset (SVSR) vs Supply Voltage

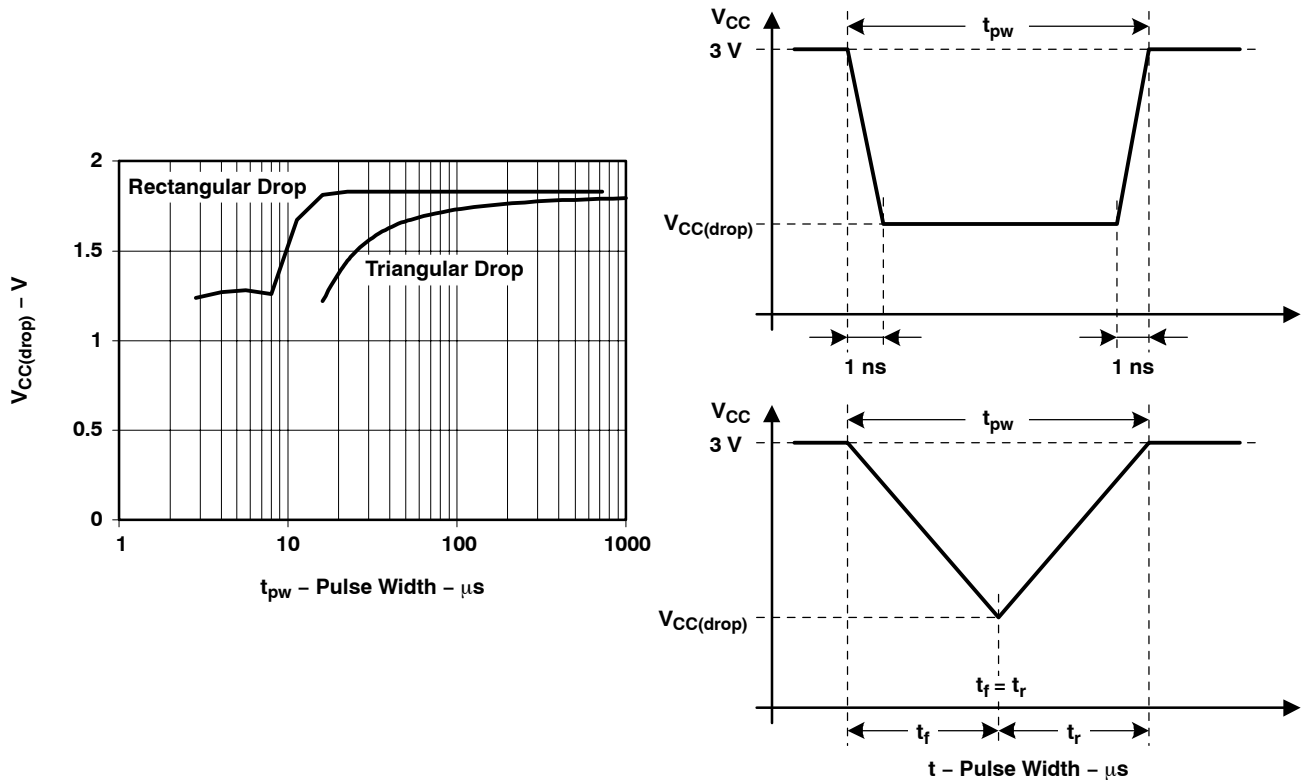

Figure 18. $V_{CC(drop)}$ With a Square Voltage Drop and a Triangle Voltage Drop to Generate an SVS Signal

MSP430x41x MIXED SIGNAL MICROCONTROLLER

SLAS340I – MAY 2001 – REVISED MARCH 2008

electrical characteristics over recommended operating free-air temperature (unless otherwise noted) (continued)

DCO

PARAMETER	TEST CONDITIONS	V _{CC}	MIN	TYP	MAX	UNIT
f _(DCOCLK)	N _(DCO) = 01Eh, FN ₈ = FN ₄ = FN ₃ = FN ₂ = 0, D = 2, DCOPLUS = 0, f _{Crystal} = 32.768 kHz	2.2 V/3 V		1		MHz
f _(DCO=2)	FN ₈ = FN ₄ = FN ₃ = FN ₂ = 0, DCOPLUS = 1	2.2 V	0.3	0.65	1.25	MHz
		3 V	0.3	0.7	1.3	
f _(DCO=27)	FN ₈ = FN ₄ = FN ₃ = FN ₂ = 0, DCOPLUS = 1	2.2 V	2.5	5.6	10.5	MHz
		3 V	2.7	6.1	11.3	
f _(DCO=2)	FN ₈ = FN ₄ = FN ₃ = 0, FN ₂ = 1, DCOPLUS = 1	2.2 V	0.7	1.3	2.3	MHz
		3 V	0.8	1.5	2.5	
f _(DCO=27)	FN ₈ = FN ₄ = FN ₃ = 0, FN ₂ = 1, DCOPLUS = 1	2.2 V	5.7	10.8	18	MHz
		3 V	6.5	12.1	20	
f _(DCO=2)	FN ₈ = FN ₄ = 0, FN ₃ = 1, FN ₂ = x, DCOPLUS = 1	2.2 V	1.2	2	3	MHz
		3 V	1.3	2.2	3.5	
f _(DCO=27)	FN ₈ = FN ₄ = 0, FN ₃ = 1, FN ₂ = x; DCOPLUS = 1	2.2 V	9	15.5	25	MHz
		3 V	10.3	17.9	28.5	
f _(DCO=2)	FN ₈ = 0, FN ₄ = 1, FN ₃ = FN ₂ = x, DCOPLUS = 1	2.2 V	1.8	2.8	4.2	MHz
		3 V	2.1	3.4	5.2	
f _(DCO=27)	FN ₈ = 0, FN ₄ = 1, FN ₃ = FN ₂ = x, DCOPLUS = 1	2.2 V	13.5	21.5	33	MHz
		3 V	16	26.6	41	
f _(DCO=2)	FN ₈ = 1, FN ₄ = FN ₃ = FN ₂ = x, DCOPLUS = 1	2.2 V	2.8	4.2	6.2	MHz
		3 V	4.2	6.3	9.2	
f _(DCO=27)	FN ₈ = 1, FN ₄ = FN ₃ = FN ₂ = x, DCOPLUS = 1	2.2 V	21	32	46	MHz
		3 V	30	46	70	
S _n	Step size between adjacent DCO taps: S _n = f _{DCO(Tap n+1)} / f _{DCO(Tap n)} (see Figure 20 for taps 21 to 27)	1 < TAP ≤ 20		1.06	1.11	
		TAP = 27		1.07	1.17	
D _t	Temperature drift, N _(DCO) = 01Eh, FN ₈ = FN ₄ = FN ₃ = FN ₂ = 0, D = 2, DCOPLUS = 0	2.2 V	-0.2	-0.3	-0.4	%/°C
		3 V	-0.2	-0.3	-0.4	
D _V	Drift with V _{CC} variation, N _(DCO) = 01Eh, FN ₈ = FN ₄ = FN ₃ = FN ₂ = 0, D = 2, DCOPLUS = 0		0	5	15	%/V

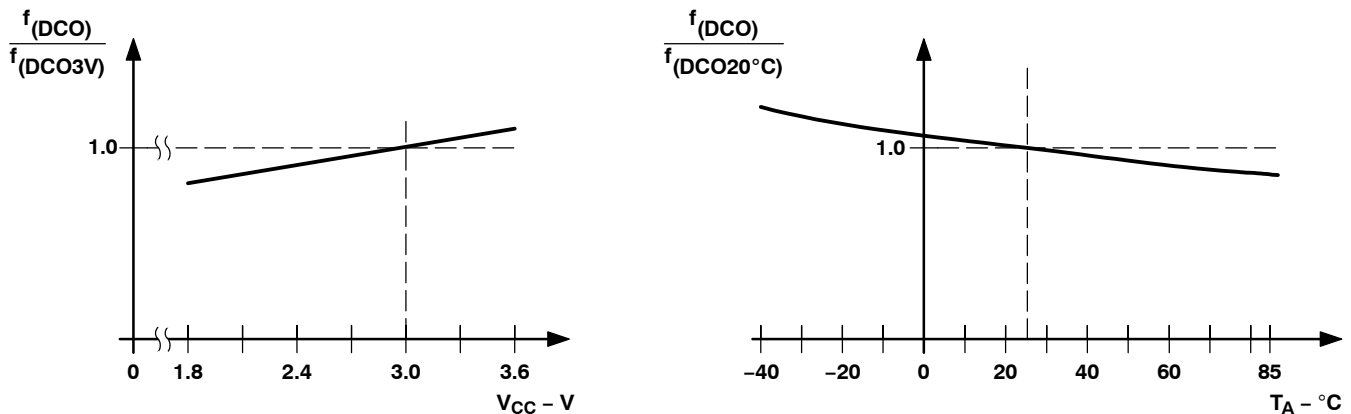

Figure 19. DCO Frequency vs Supply Voltage V_{CC} and vs Ambient Temperature



electrical characteristics over recommended operating free-air temperature (unless otherwise noted) (continued)

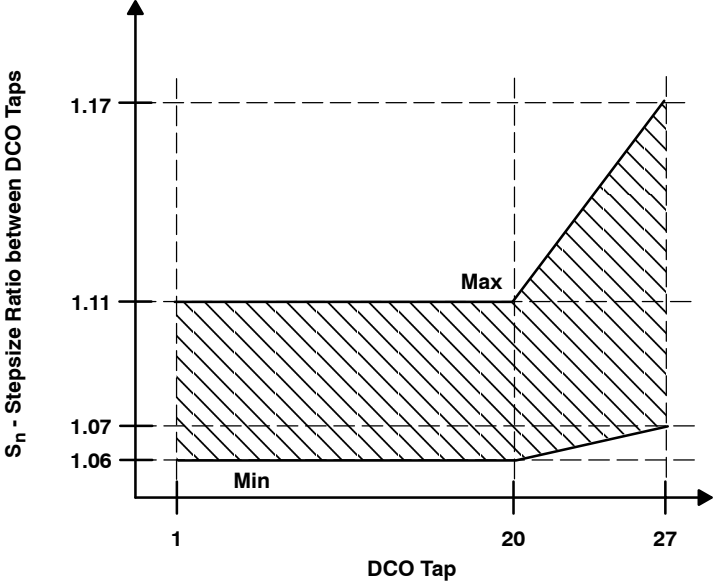

Figure 20. DCO Tap Step Size

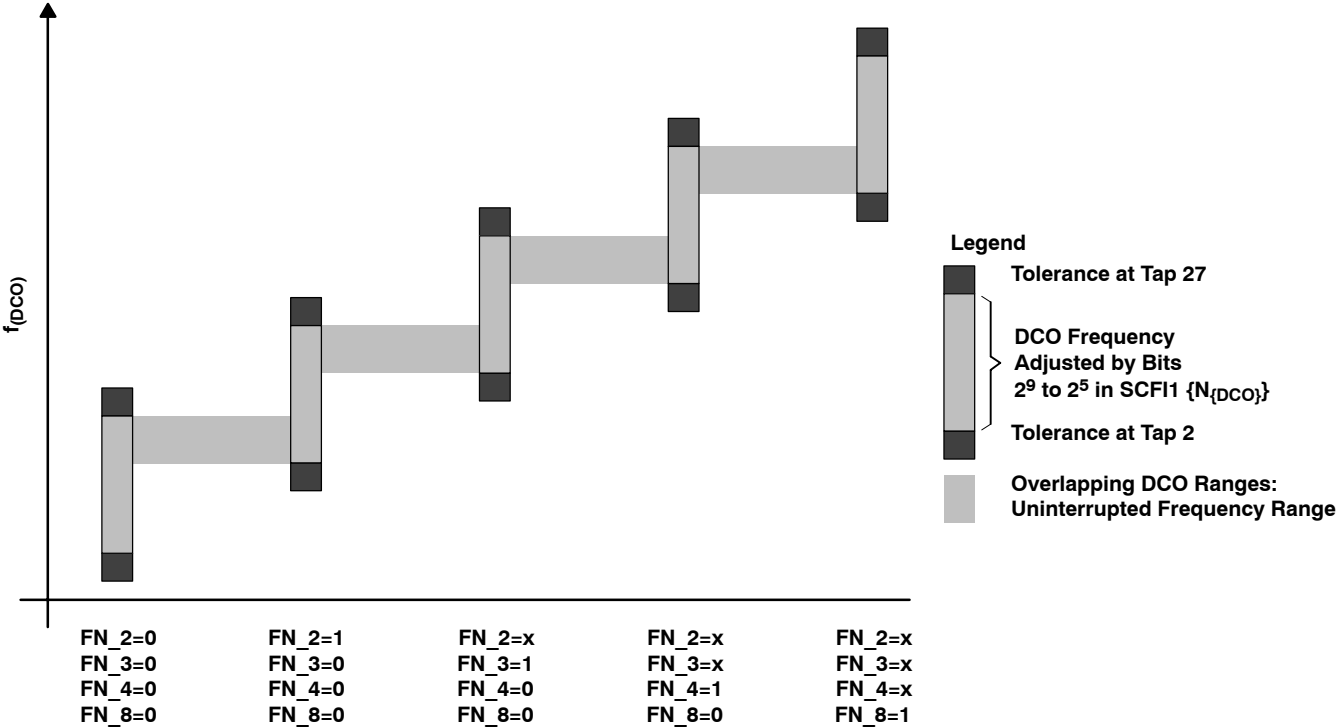

Figure 21. Five Overlapping DCO Ranges Controlled by FN_x Bits

MSP430x41x MIXED SIGNAL MICROCONTROLLER

SLAS340I – MAY 2001 – REVISED MARCH 2008

electrical characteristics over recommended operating free-air temperature (unless otherwise noted) (continued)

crystal oscillator, LFXT1 oscillator (see Notes 1 and 2)

PARAMETER		TEST CONDITIONS	V _{CC}	MIN	TYP	MAX	UNIT
C _{XIN}	Integrated load capacitance	OSCCAPx = 0h	2.2 V/3 V		0		pF
		OSCCAPx = 1h			10		
		OSCCAPx = 2h			14		
		OSCCAPx = 3h			18		
C _{XOUT}	Integrated load capacitance	OSCCAPx = 0h	2.2 V/3 V		0		pF
		OSCCAPx = 1h			10		
		OSCCAPx = 2h			14		
		OSCCAPx = 3h			18		
V _{IL}	Input levels at XIN	see Note 3	2.2 V/3 V	V _{SS}		0.2×V _{CC}	V
V _{IH}			2.2 V/3 V	0.8×V _{CC}		V _{CC}	

- NOTES:
- The parasitic capacitance from the package and board may be estimated to be 2pF. The effective load capacitor for the crystal is $(C_{XIN} \times C_{XOUT}) / (C_{XIN} + C_{XOUT})$. It is independent of XTS_FLL.
 - To improve EMI on the low-power LFXT1 oscillator, particularly in the LF mode (32 kHz), the following guidelines must be observed:
 - Keep the trace between the MSP430x41x and the crystal as short as possible.
 - Design a good ground plane around oscillator pins.
 - Prevent crosstalk from other clock or data lines into oscillator pins XIN and XOUT.
 - Avoid running PCB traces underneath or adjacent to XIN and XOUT pins.
 - Use assembly materials and praxis to avoid any parasitic load on the oscillator XIN and XOUT pins.
 - If conformal coating is used, ensure that it does not induce capacitive/resistive leakage between the oscillator pins.
 - Do not route the XOUT line to the JTAG header to support the serial programming adapter as shown in other documentation. This signal is no longer required for the serial programming adapter.
 - Applies only when using an external logic-level clock source. XTS_FLL must be set. Not applicable when using a crystal or resonator.
 - External capacitance is recommended for precision real-time clock applications; OSCCAPx = 0h.

electrical characteristics over recommended operating free-air temperature (unless otherwise noted) (continued)

flash memory

PARAMETER		TEST CONDITIONS	V _{CC}	MIN	TYP	MAX	UNIT
V _{CC(PGM/ERASE)}	Program and erase supply voltage			2.7		3.6	V
f _{FTG}	Flash timing generator frequency			257		476	kHz
I _{PGM}	Supply current from DV _{CC} during program		2.7 V/ 3.6 V		3	5	mA
I _{ERASE}	Supply current from DV _{CC} during erase		2.7 V/ 3.6 V		3	7	mA
t _{CPT}	Cumulative program time	See Note 1	2.7 V/ 3.6 V			10	ms
t _{CMErase}	Cumulative mass erase time	See Note 2	2.7 V/ 3.6 V	200			ms
	Program/erase endurance			10 ⁴	10 ⁵		cycles
t _{Retention}	Data retention duration	T _J = 25°C		100			years
t _{Word}	Word or byte program time	See Note 3			35		t _{FTG}
t _{Block, 0}	Block program time for 1 st byte or word				30		
t _{Block, 1-63}	Block program time for each additional byte or word				21		
t _{Block, End}	Block program end-sequence wait time				6		
t _{Mass Erase}	Mass erase time				5297		
t _{Seg Erase}	Segment erase time				4819		

- NOTES: 1. The cumulative program time must not be exceeded when writing to a 64-byte flash block. This parameter applies to all programming methods: individual word/byte write and block write modes.
2. The mass erase duration generated by the flash timing generator is at least 11.1 ms (= 5297x1/f_{FTG,max} = 5297x1/476kHz). To achieve the required cumulative mass erase time the flash controller's mass erase operation can be repeated until this time is met. (A worst case minimum of 19 cycles are required).
3. These values are hardwired into the flash controller's state machine (t_{FTG} = 1/f_{FTG}).

JTAG interface

PARAMETER		TEST CONDITIONS	V _{CC}	MIN	TYP	MAX	UNIT
f _{TCK}	TCK input frequency	see Note 1	2.2 V	0		5	MHz
			3 V	0		10	MHz
R _{Internal}	Internal pull-up resistance on TMS, TCK, TDI/TCLK	see Note 2	2.2 V/ 3 V	25	60	90	kΩ

- NOTES: 1. f_{TCK} may be restricted to meet the timing requirements of the module selected.
2. TMS, TDI/TCLK, and TCK pullup resistors are implemented in all versions.

JTAG fuse (see Note 1)

PARAMETER		TEST CONDITIONS	MIN	MAX	UNIT
V _{CC(FB)}	Supply voltage during fuse-blow condition	T _A = 25°C	2.5		V
V _{FB}	Voltage level on TDI/TCLK for fuse-blow	MSP430C41x	3.5	3.9	V
		MSP430F41x	6	7	V
I _{FB}	Supply current into TDI/TCLK during fuse blow			100	mA
t _{FB}	Time to blow fuse			1	ms

- NOTES: 1. Once the fuse is blown, no further access to the MSP430 JTAG/Test and emulation features is possible. The JTAG block is switched to bypass mode.

MSP430x41x MIXED SIGNAL MICROCONTROLLER

SLAS340I – MAY 2001 – REVISED MARCH 2008

APPLICATION INFORMATION

input/output schematics

Port P1, P1.0 to P1.5, input/output with Schmitt trigger

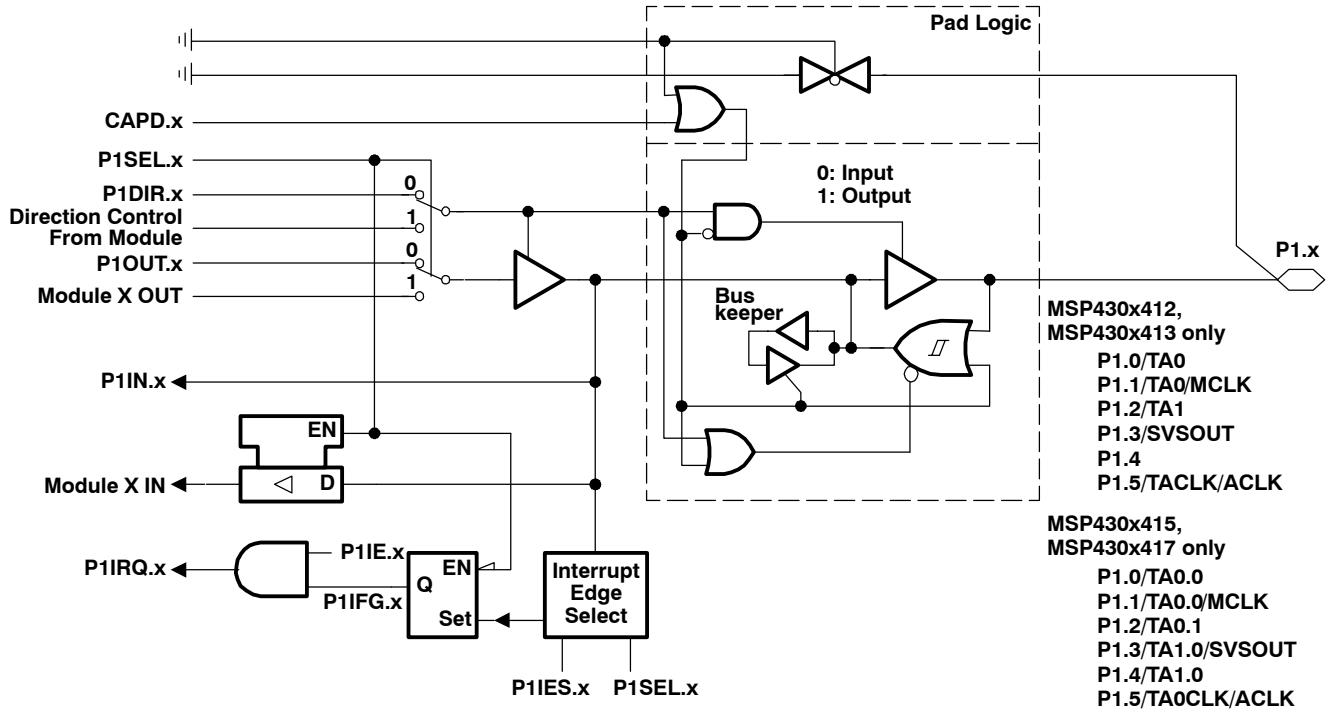

NOTE: $0 \leq x \leq 5$.
Port Function is Active if CAPD.x = 0

PnSEL.x	PnDIR.x	Direction Control From Module	PnOUT.x	Module X OUT	PnIN.x	Module X IN	PnIE.x	PnIFG.x	PnIES.x
P1SEL.0	P1DIR.0	P1DIR.0	P1OUT.0	Out0 Sig. [†]	P1IN.0	CCI0A [†]	P1IE.0	P1IFG.0	P1IES.0
P1SEL.1	P1DIR.1	P1DIR.1	P1OUT.1	MCLK	P1IN.1	CCI0B [†]	P1IE.1	P1IFG.1	P1IES.1
P1SEL.2	P1DIR.2	P1DIR.2	P1OUT.2	Out1 Sig. [†]	P1IN.2	CCI1A [†]	P1IE.2	P1IFG.2	P1IES.2
P1SEL.3	P1DIR.3	P1DIR.3	P1OUT.3	SVSOUT	P1IN.3	Unused	P1IE.3	P1IFG.3	P1IES.3
P1SEL.4	P1DIR.4	P1DIR.4	P1OUT.4	DVSS [§] Out0 Sig. [‡]	P1IN.4	Unused [§] CCI0A [†]	P1IE.4	P1IFG.4	P1IES.4
P1SEL.5	P1DIR.5	P1DIR.5	P1OUT.5	ACLK	P1IN.5	TACLK [†]	P1IE.5	P1IFG.5	P1IES.5

[†] Timer_A3/Timer0_A3

[‡] Timer1_A5 (MSP430x415, MSP430x417 only)

[§] MSP430x412, MSP430x413 only

APPLICATION INFORMATION

Port P1, P1.6, P1.7 input/output with Schmitt trigger

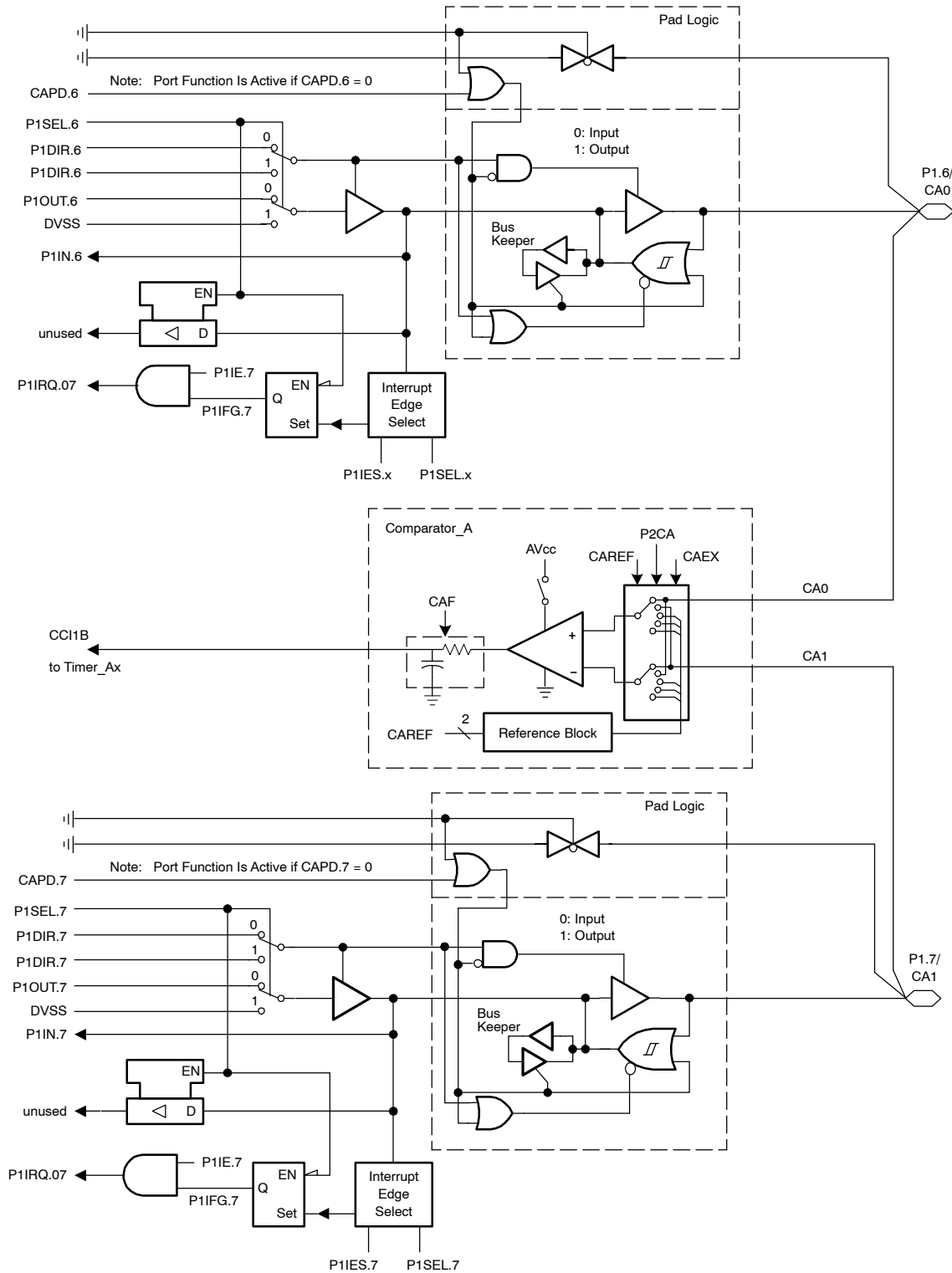

MSP430x41x MIXED SIGNAL MICROCONTROLLER

SLAS340I – MAY 2001 – REVISED MARCH 2008

APPLICATION INFORMATION

port P2, P2.0 to P2.7, input/output with Schmitt trigger

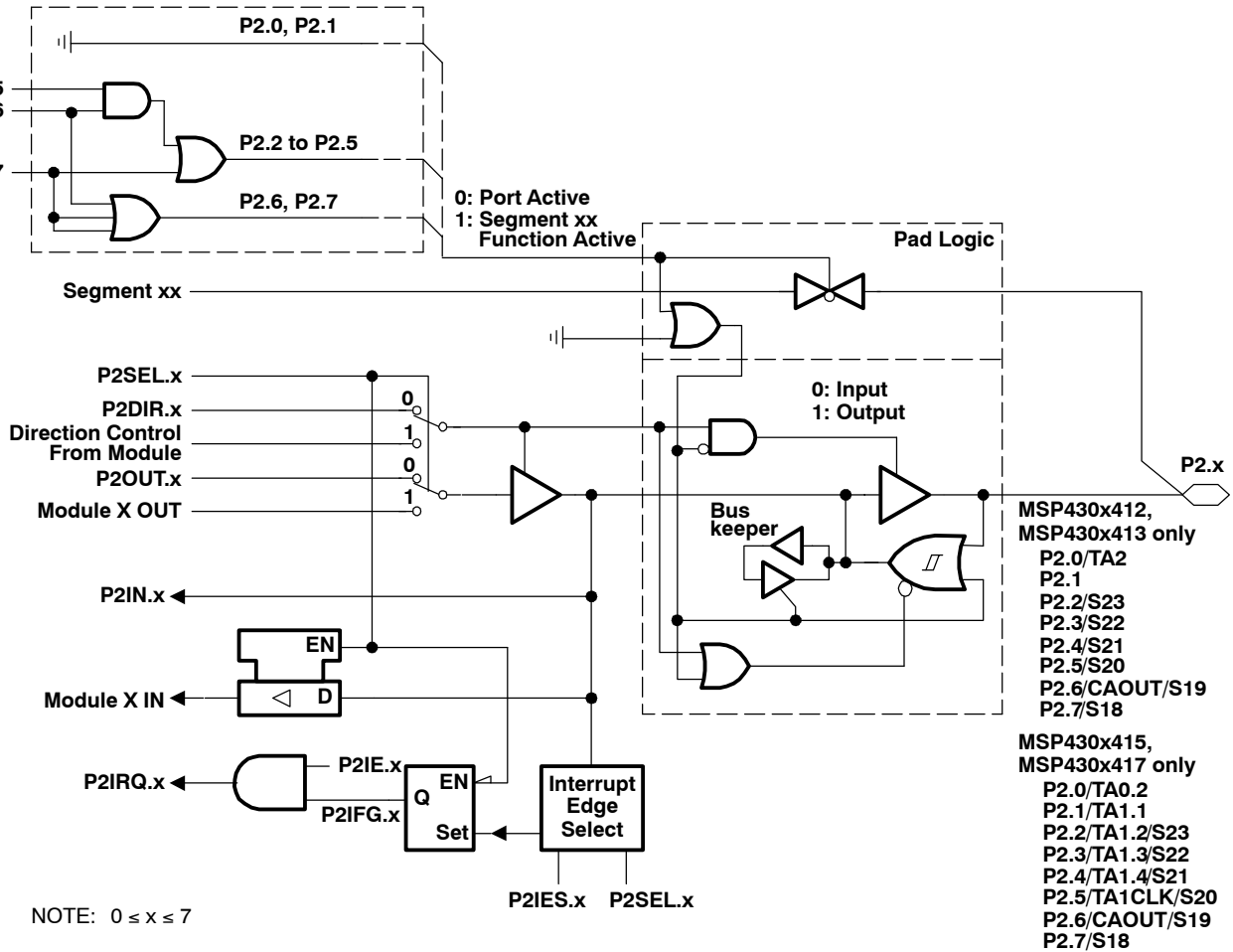

PnSEL.x	PnDIR.x	Direction Control From Module	PnOUT.x	Module X OUT	PnIN.x	Module X IN	PnIE.x	PnIFG.x	PnIES.x
P2SEL.0	P2DIR.0	P2DIR.0	P2OUT.0	Out2 Sig. [†]	P2IN.0	CCI2A [†]	P2IE.0	P2IFG.0	P2IES.0
P2SEL.1	P2DIR.1	P2DIR.1	P2OUT.1	DVSS [§] Out1 Sig. [‡]	P2IN.1	Unused [§] CCI1A [†]	P2IE.1	P2IFG.1	P2IES.1
P2SEL.2	P2DIR.2	P2DIR.2	P2OUT.2	DVSS [§] Out2 Sig. [‡]	P2IN.2	Unused [§] CCI2A [†]	P2IE.2	P2IFG.2	P2IES.2
P2SEL.3	P2DIR.3	P2DIR.3	P2OUT.3	DVSS [§] Out3 Sig. [‡]	P2IN.3	Unused [§] CCI3A [†]	P2IE.3	P2IFG.3	P2IES.3
P2SEL.4	P2DIR.4	P2DIR.4	P2OUT.4	DVSS [§] Out4 Sig. [‡]	P2IN.4	Unused [§] CCI4A [†]	P2IE.4	P2IFG.4	P2IES.4
P2SEL.5	P2DIR.5	P2DIR.5	P2OUT.5	DVSS	P2IN.5	Unused [§] TA1CLK [‡]	P2IE.5	P2IFG.5	P2IES.5
P2SEL.6	P2DIR.6	P2DIR.6	P2OUT.6	CAOUT	P2IN.6	Unused	P2IE.6	P2IFG.6	P2IES.6
P2SEL.7	P2DIR.7	P2DIR.7	P2OUT.7	DVSS	P2IN.7	Unused	P2IE.7	P2IFG.7	P2IES.7

[†] Timer_A3/Timer0_A3

[‡] Timer1_A5 (MSP430x415, MSP430x417 only)

[§] MSP430x412, MSP430x413 only



POST OFFICE BOX 655303 • DALLAS, TEXAS 75265

APPLICATION INFORMATION

port P3, P3.0 to P3.7, input/output with Schmitt trigger

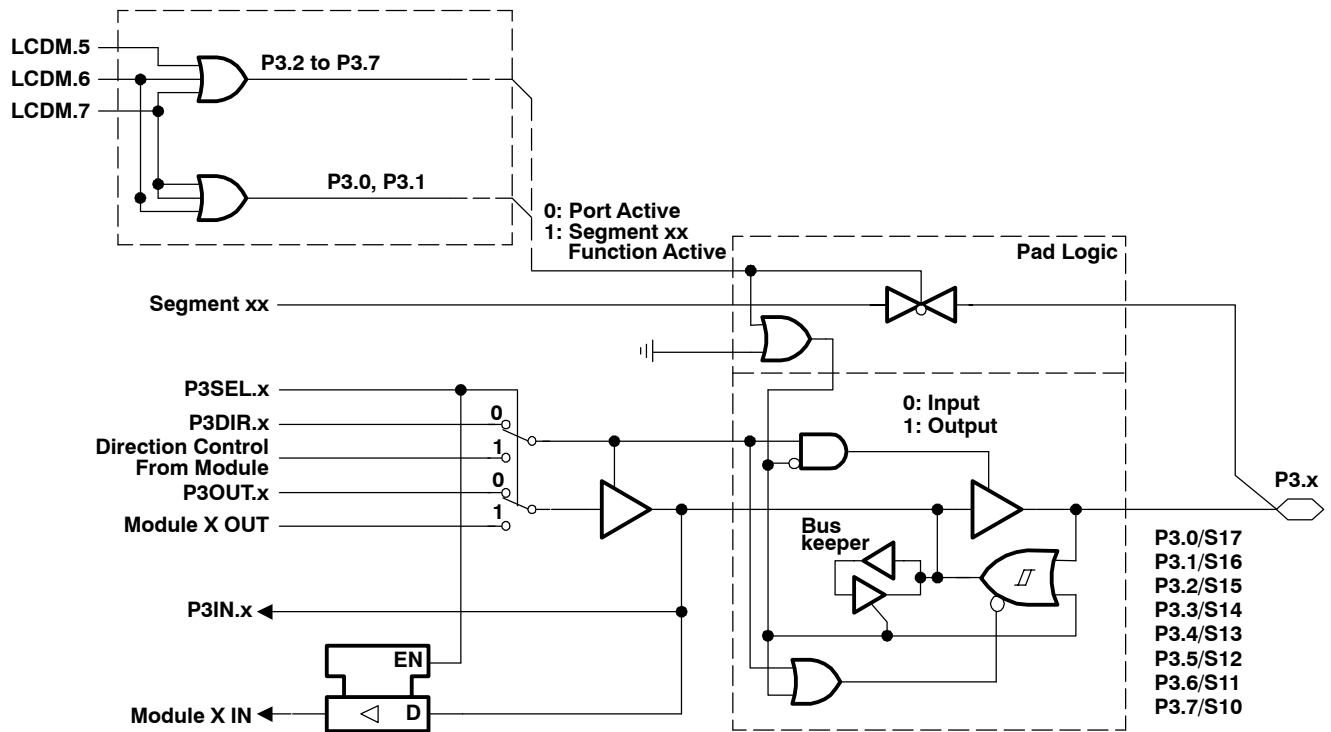

NOTE: $0 \leq x \leq 7$

PnSEL.x	PnDIR.x	Direction Control From Module	PnOUT.x	Module X OUT	PnIN.x	Module X IN
P3SEL.0	P3DIR.0	P3DIR.0	P3OUT.0	DVSS	P3IN.0	Unused
P3SEL.1	P3DIR.1	P3DIR.1	P3OUT.1	DVSS	P3IN.1	Unused
P3SEL.2	P3DIR.2	P3DIR.2	P3OUT.2	DVSS	P3IN.2	Unused
P3SEL.3	P3DIR.3	P3DIR.3	P3OUT.3	DVSS	P3IN.3	Unused
P3SEL.4	P3DIR.4	P3DIR.4	P3OUT.4	DVSS	P3IN.4	Unused
P3SEL.5	P3DIR.5	P3DIR.5	P3OUT.5	DVSS	P3IN.5	Unused
P3SEL.6	P3DIR.6	P3DIR.6	P3OUT.6	DVSS	P3IN.6	Unused
P3SEL.7	P3DIR.7	P3DIR.7	P3OUT.7	DVSS	P3IN.7	Unused

MSP430x41x MIXED SIGNAL MICROCONTROLLER

SLAS340I – MAY 2001 – REVISED MARCH 2008

APPLICATION INFORMATION

port P4, P4.0 to P4.7, input/output with Schmitt trigger

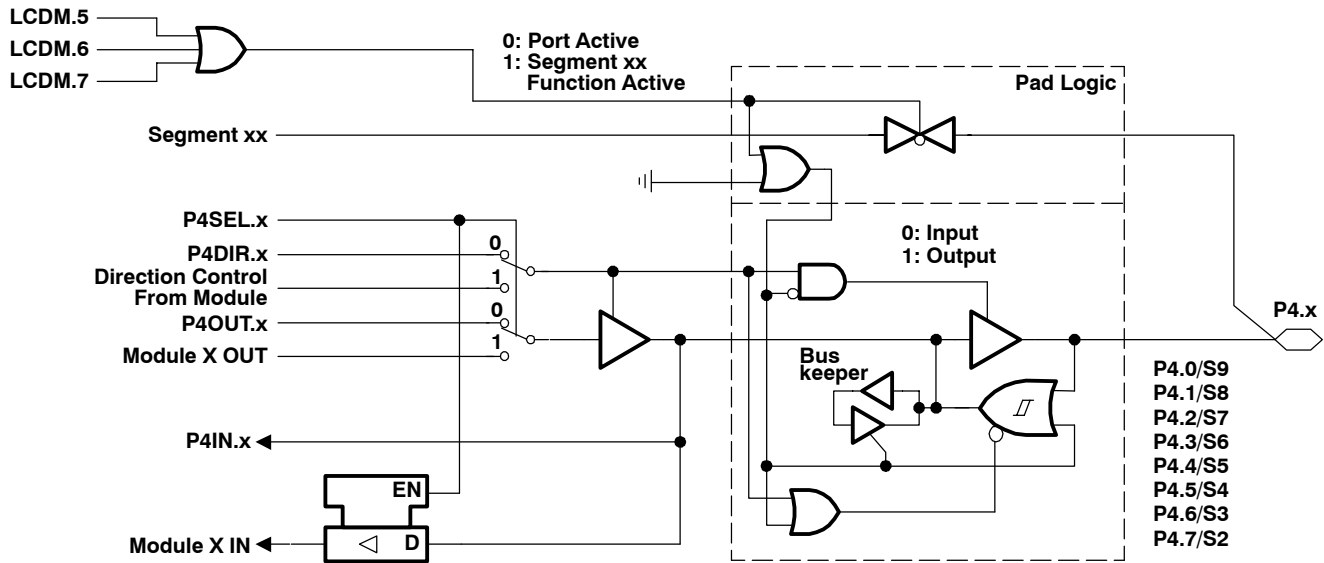

NOTE: $0 \leq x \leq 7$

PnSEL.x	PnDIR.x	Direction Control From Module	PnOUT.x	Module X OUT	PnIN.x	Module X IN
P4SEL.0	P4DIR.0	P4DIR.0	P4OUT.0	DVSS	P4IN.0	Unused
P4SEL.1	P4DIR.1	P4DIR.1	P4OUT.1	DVSS	P4IN.1	Unused
P4SEL.2	P4DIR.2	P4DIR.2	P4OUT.2	DVSS	P4IN.2	Unused
P4SEL.3	P4DIR.3	P4DIR.3	P4OUT.3	DVSS	P4IN.3	Unused
P4SEL.4	P4DIR.4	P4DIR.4	P4OUT.4	DVSS	P4IN.4	Unused
P4SEL.5	P4DIR.5	P4DIR.5	P4OUT.5	DVSS	P4IN.5	Unused
P4SEL.6	P4DIR.6	P4DIR.6	P4OUT.6	DVSS	P4IN.6	Unused
P4SEL.7	P4DIR.7	P4DIR.7	P4OUT.7	DVSS	P4IN.7	Unused

APPLICATION INFORMATION

port P5, P5.0, P5.1, input/output with Schmitt trigger

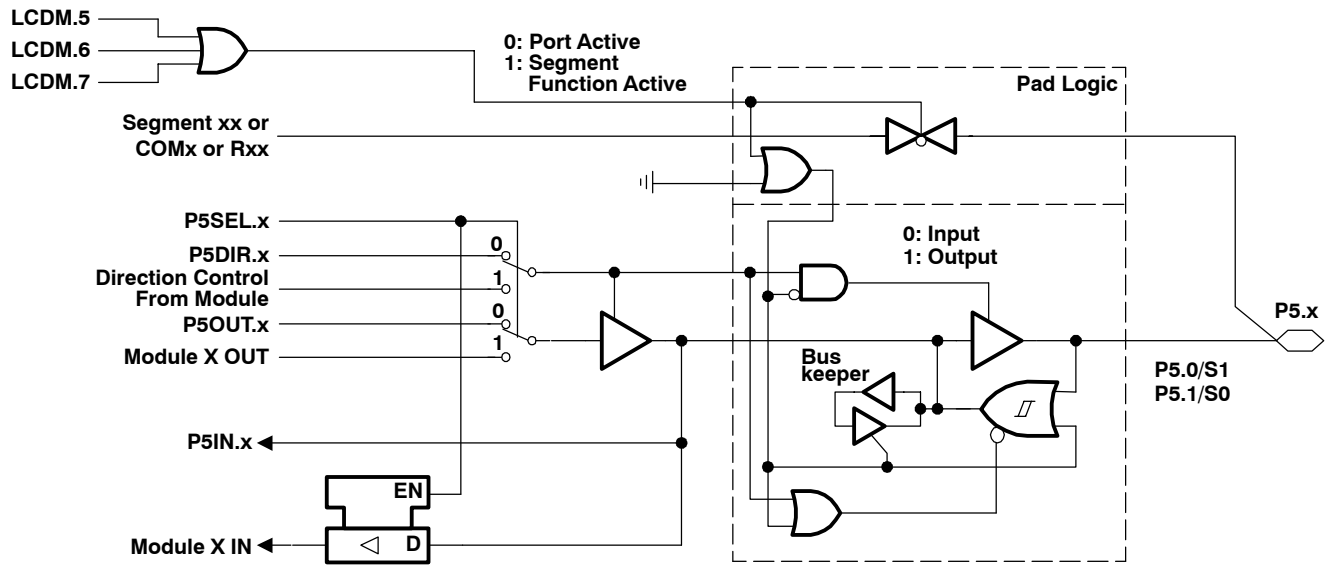

NOTE: x = 0, 1

PnSEL.x	PnDIR.x	Direction Control From Module	PnOUT.x	Module X OUT	PnIN.x	Module X IN	Segment
P5SEL.0	P5DIR.0	P5DIR.0	P5OUT.0	DVSS	P5IN.0	Unused	S1
P5SEL.1	P5DIR.1	P5DIR.1	P5OUT.1	DVSS	P5IN.1	Unused	S0

MSP430x41x MIXED SIGNAL MICROCONTROLLER

SLAS340I – MAY 2001 – REVISED MARCH 2008

APPLICATION INFORMATION

port P5, P5.2 to P5.4, input/output with Schmitt trigger

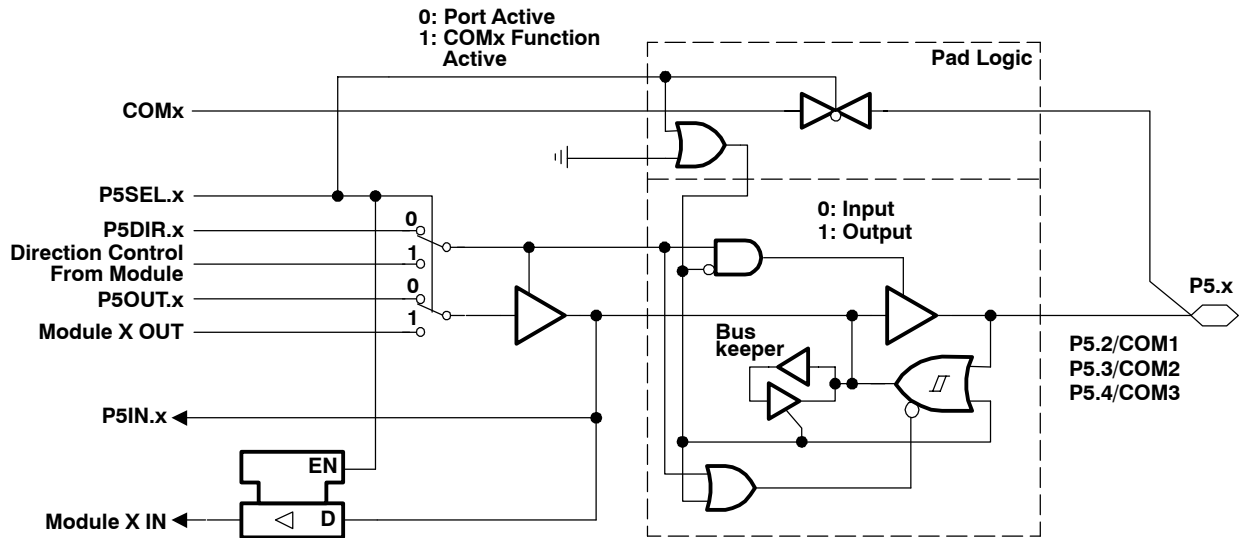

NOTE: $2 \leq x \leq 4$

PnSEL.x	PnDIR.x	Direction Control From Module	PnOUT.x	Module X OUT	PnIN.x	Module X IN	COMx
P5SEL.2	P5DIR.2	P5DIR.2	P5OUT.2	DVSS	P5IN.2	Unused	COM1
P5SEL.3	P5DIR.3	P5DIR.3	P5OUT.3	DVSS	P5IN.3	Unused	COM2
P5SEL.4	P5DIR.4	P5DIR.4	P5OUT.4	DVSS	P5IN.4	Unused	COM3

NOTE:

The direction control bits P5SEL.2, P5SEL.3, and P5SEL.4 are used to distinguish between port and common functions. Note that a 4MUX LCD requires all common signals COM3 to COM0, a 3MUX LCD requires COM2 to COM0, 2MUX LCD requires COM1 to COM0, and a static LCD requires only COM0.

APPLICATION INFORMATION

port P5, P5.5 to P5.7, input/output with Schmitt trigger

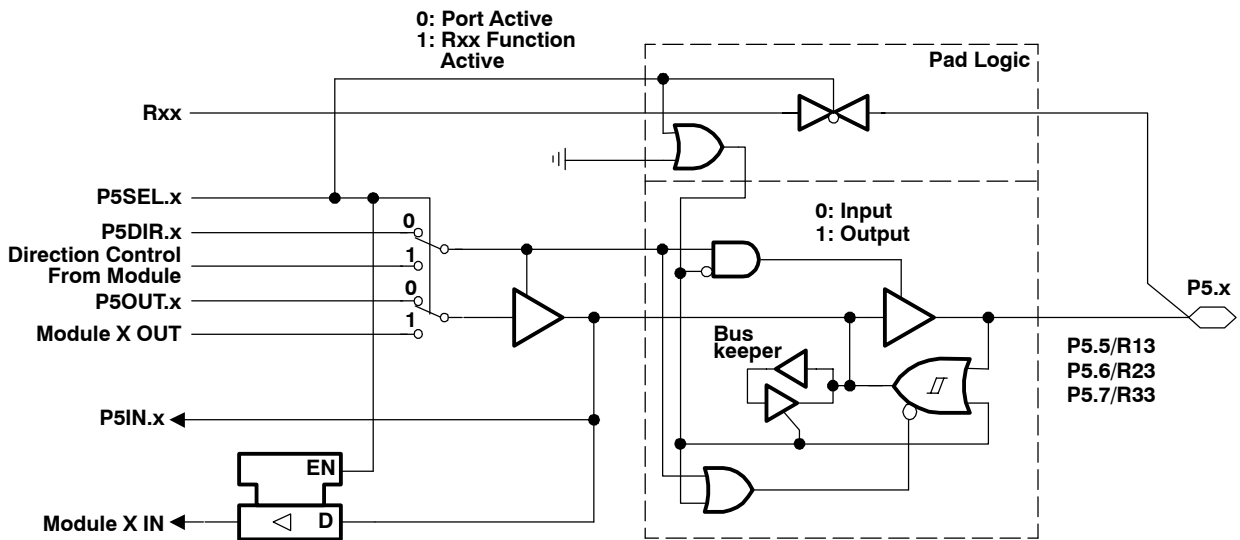

NOTE: $5 \leq x \leq 7$

PnSEL.x	PnDIR.x	Direction Control From Module	PnOUT.x	Module X OUT	PnIN.x	Module X IN	Rxx
P5SEL.5	P5DIR.5	P5DIR.5	P5OUT.5	DVSS	P5IN.5	Unused	R13
P5SEL.6	P5DIR.6	P5DIR.6	P5OUT.6	DVSS	P5IN.6	Unused	R23
P5SEL.7	P5DIR.7	P5DIR.7	P5OUT.7	DVSS	P5IN.7	Unused	R33

NOTE:

The direction control bits P5SEL.5, P5SEL.6, and P5SEL.7 are used to distinguish between port and LCD analog level functions. Note that 4MUX and 3MUX LCDs require all Rxx signals R33 to R03, a 2MUX LCD requires R33, R13, and R03, and a static LCD requires only R33 and R03.

MSP430x41x MIXED SIGNAL MICROCONTROLLER

SLAS340I – MAY 2001 – REVISED MARCH 2008

APPLICATION INFORMATION

port P6, P6.0 to P6.6, input/output with Schmitt trigger

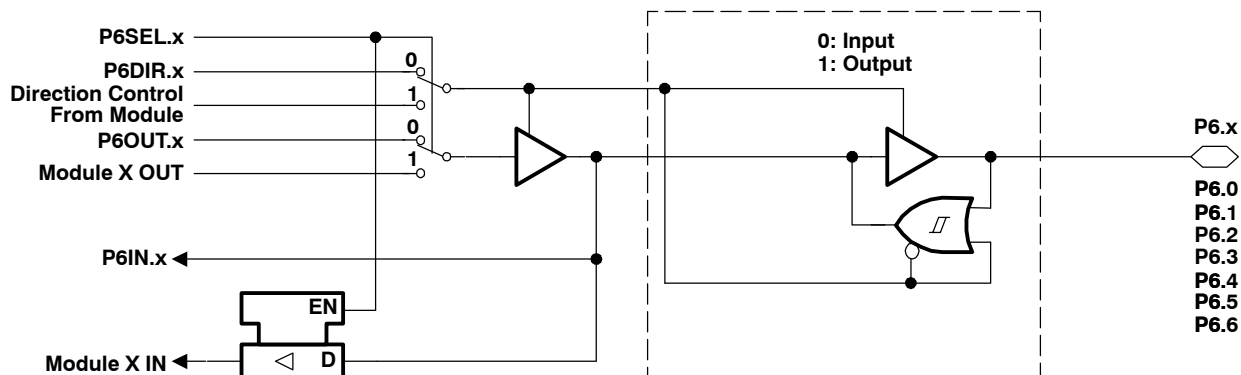

NOTE: $0 \leq x \leq 6$

PnSEL.x	PnDIR.x	Direction Control From Module	PnOUT.x	Module X OUT	PnIN.x	Module X IN
P6SEL.0	P6DIR.0	P6DIR.0	P6OUT.0	DVSS	P6IN.0	Unused
P6SEL.1	P6DIR.1	P6DIR.1	P6OUT.1	DVSS	P6IN.1	Unused
P6SEL.2	P6DIR.2	P6DIR.2	P6OUT.2	DVSS	P6IN.2	Unused
P6SEL.3	P6DIR.3	P6DIR.3	P6OUT.3	DVSS	P6IN.3	Unused
P6SEL.4	P6DIR.4	P6DIR.4	P6OUT.4	DVSS	P6IN.4	Unused
P6SEL.5	P6DIR.5	P6DIR.5	P6OUT.5	DVSS	P6IN.5	Unused
P6SEL.6	P6DIR.6	P6DIR.6	P6OUT.6	DVSS	P6IN.6	Unused

APPLICATION INFORMATION

port P6, P6.7 input/output with Schmitt trigger (MSP430x412/413 only)

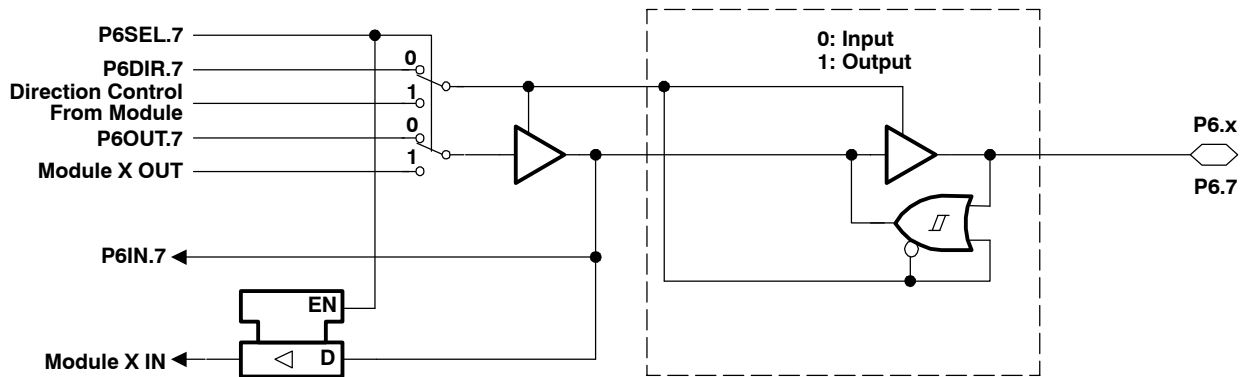

PnSEL.x	PnDIR.x	Direction Control From Module	PnOUT.x	Module X OUT	PnIN.x	Module X IN
P6SEL.7	P6DIR.7	P6DIR.7	P6OUT.7	DVSS	P6IN.7	Unused

MSP430x41x MIXED SIGNAL MICROCONTROLLER

SLAS340I – MAY 2001 – REVISED MARCH 2008

APPLICATION INFORMATION

port P6, P6.7 input/output with Schmitt trigger (MSP430F415/417 only)

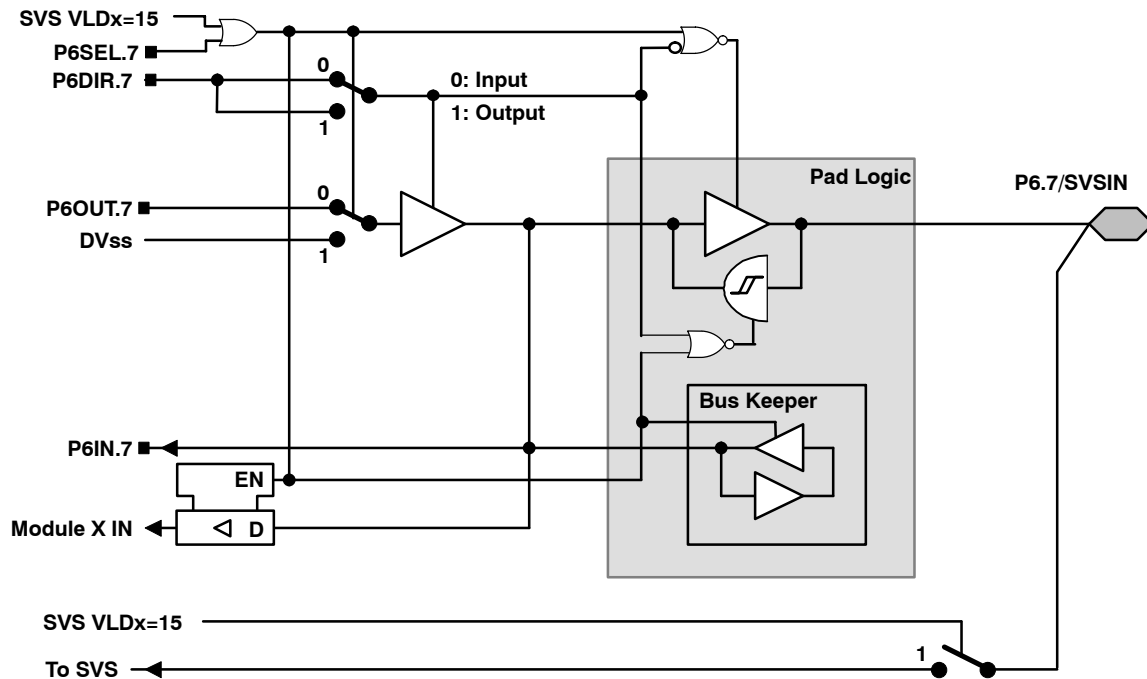

NOTE: Analog signals applied to digital gates can cause current flow from the positive to the negative terminal. The throughput current flows if the analog signal is in the range of transitions 0→1 or 1→0. The value of the throughput current depends on the driving capability of the gate. For MSP430, it is approximately 100 μ A. Use P6SEL.x=1 to prevent throughput current. P6SEL.x should be set, if an analog signal is applied to the pin.

SWS VLDx = 15	P6SEL.7	P6DIR.7	Port Function
0	0	0	P6.7 Input
0	0	1	P6.7 Output
0	1	X	Undefined
1	X	X	SVSIN

APPLICATION INFORMATION

JTAG pins (TMS, TCK, TDI/TCLK, TDO/TDI), input/output with Schmitt trigger or output

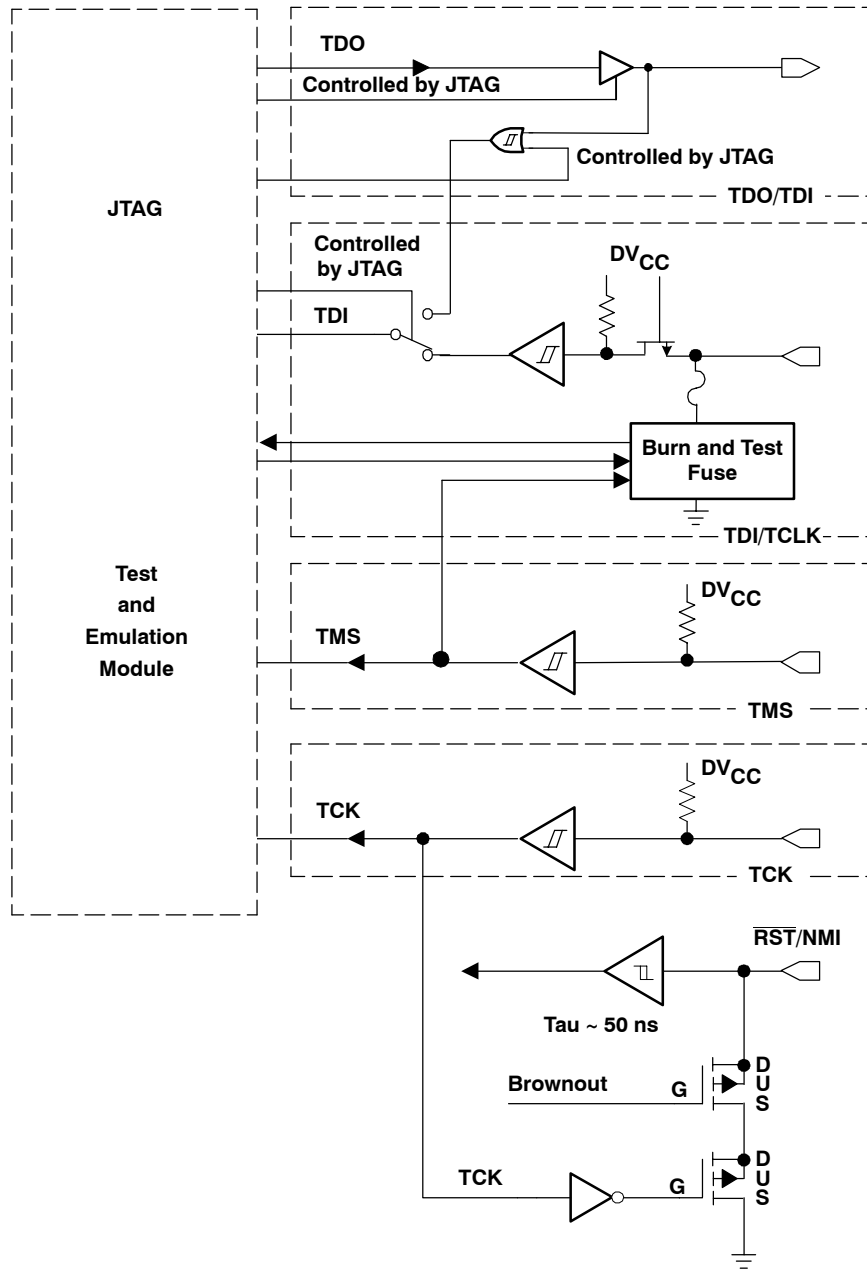

APPLICATION INFORMATION

JTAG fuse check mode

MSP430 devices that have the fuse on the TDI/TCLK terminal have a fuse check mode that tests the continuity of the fuse the first time the JTAG port is accessed after a power-on reset (POR). When activated, a fuse check current, I_{TF} , of 1.8 mA at 3 V can flow from the TDI/TCLK pin to ground if the fuse is not burned. Care must be taken to avoid accidentally activating the fuse check mode and increasing overall system power consumption.

Activation of the fuse check mode occurs with the first negative edge on the TMS pin after power up or if the TMS is being held low during power up. The second positive edge on the TMS pin deactivates the fuse check mode. After deactivation, the fuse check mode remains inactive until another POR occurs. After each POR the fuse check mode has the potential to be activated.

The fuse check current only flows when the fuse check mode is active and the TMS pin is in a low state (see Figure 22). Therefore, the additional current flow can be prevented by holding the TMS pin high (default condition).

The JTAG pins are terminated internally, and therefore do not require external termination.

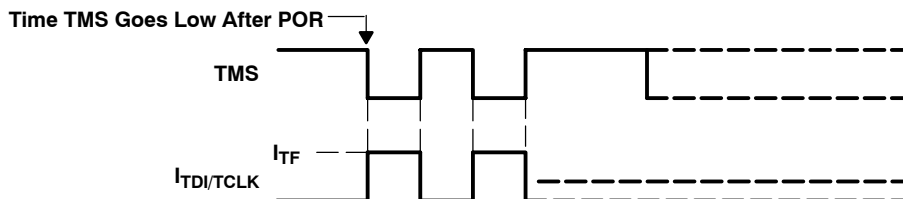

Figure 22. Fuse Check Mode Current, MSP430C41x, MSP430F41x

Data Sheet Revision History

Literature Number	Summary
SLAS340H	Updated functional block diagrams (page 4) Clarified test conditions in recommended operating conditions table (page 21) Split Supply voltage during program execution for MSP430x412/413 and MSP430x415/417 (page 21) Clarified test conditions for $I_{(LPM0)}$ in supply current into $AV_{CC} + DV_{CC}$ table (page 22) Added P2–P5 to leakage current table (page 23) Changed t_{CP1} maximum value from 4 ms to 10 ms in Flash memory table (page 37)
SLAS340I	Changed all RTD package options for MSP430C41x to RGC package.

NOTE: Page and figure numbers refer to the respective document revision.

MSP430x41x MIXED SIGNAL MICROCONTROLLER

SLAS340I – MAY 2001 – REVISED MARCH 2008

MECHANICAL DATA

RGC (S-PQFP-N64) CUSTOM DEVICE PLASTIC QUAD FLATPACK

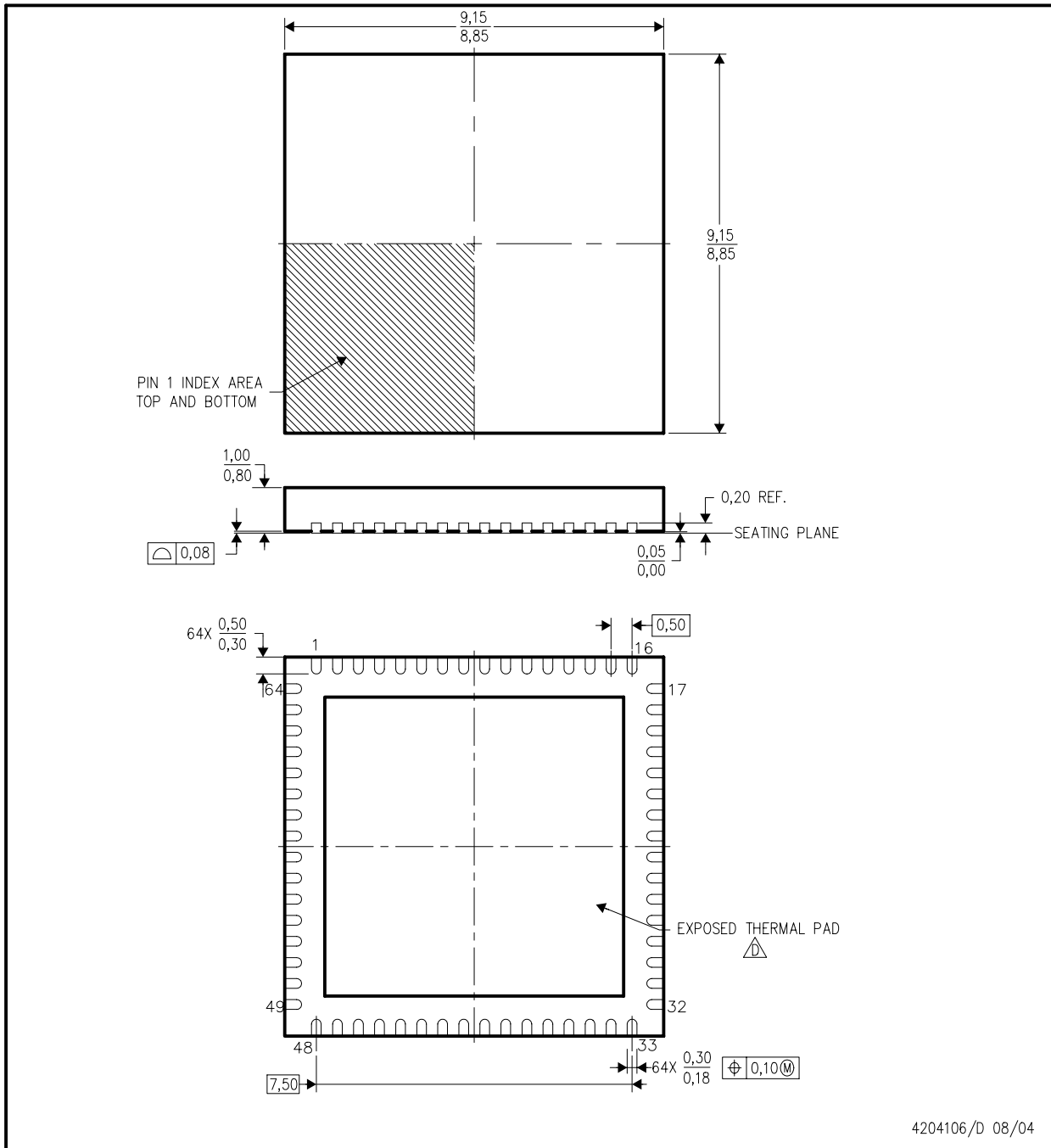

4204106/D 08/04

- NOTES:
- A. All linear dimensions are in millimeters. Dimensioning and tolerancing per ASME Y14.5-1994.
 - B. This drawing is subject to change without notice.
 - C. Quad Flatpack, No-leads (QFN) package configuration .
 -  The package thermal pad must be soldered to the board for thermal and mechanical performance. See the Product Data Sheet for details regarding the exposed thermal pad dimensions.



POST OFFICE BOX 655303 • DALLAS, TEXAS 75265

THERMAL INFORMATION

RGC (S-PQFP-N64)

This package incorporates an exposed thermal pad that is designed to be attached directly to an external heatsink. The thermal pad must be soldered directly to the printed circuit board (PCB). After soldering, the PCB can be used as a heatsink. In addition, through the use of thermal vias, the thermal pad can be attached directly to the appropriate copper plane shown in the electrical schematic for the device, or alternatively, can be attached to a special heatsink structure designed into the PCB. This design optimizes the heat transfer from the integrated circuit (IC).

For information on the Quad Flatpack No-Lead (QFN) package and its advantages, refer to Application Report, Quad Flatpack No-Lead Logic Packages, Texas Instruments Literature No. SCBA017. This document is available at www.ti.com.

The exposed thermal pad dimensions for this package are shown in the following illustration.

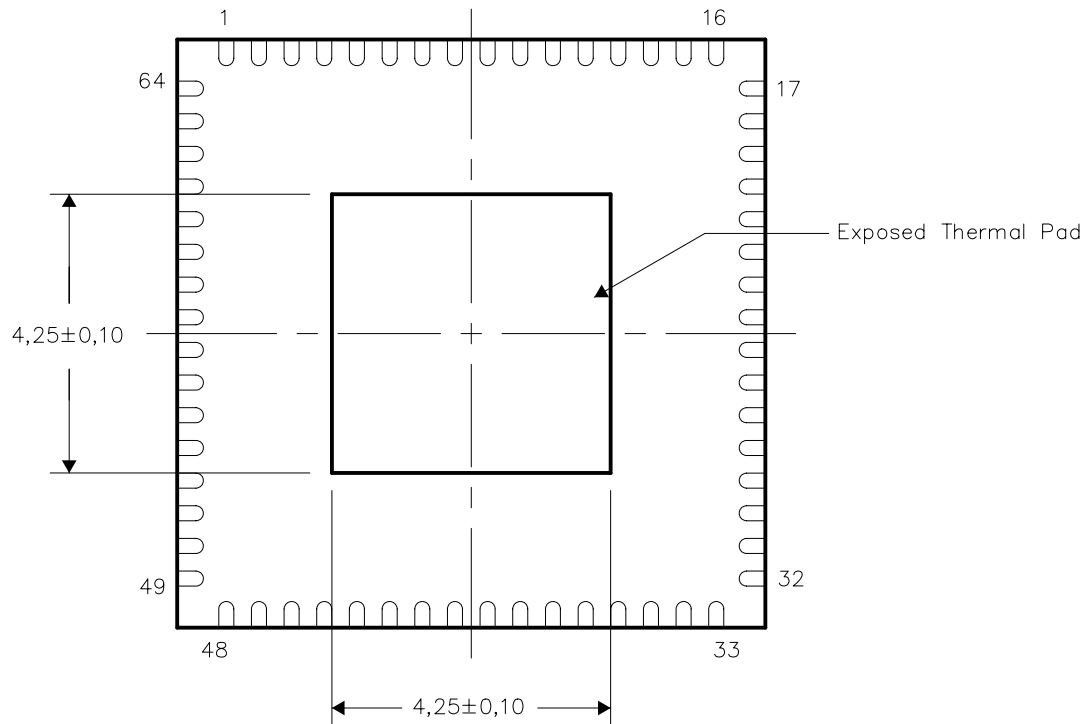

Bottom View

NOTE: All linear dimensions are in millimeters

Exposed Thermal Pad Dimensions

MSP430x41x MIXED SIGNAL MICROCONTROLLER

SLAS340I – MAY 2001 – REVISED MARCH 2008

RGC (S-PQFP-N64)

LAND PATTERN

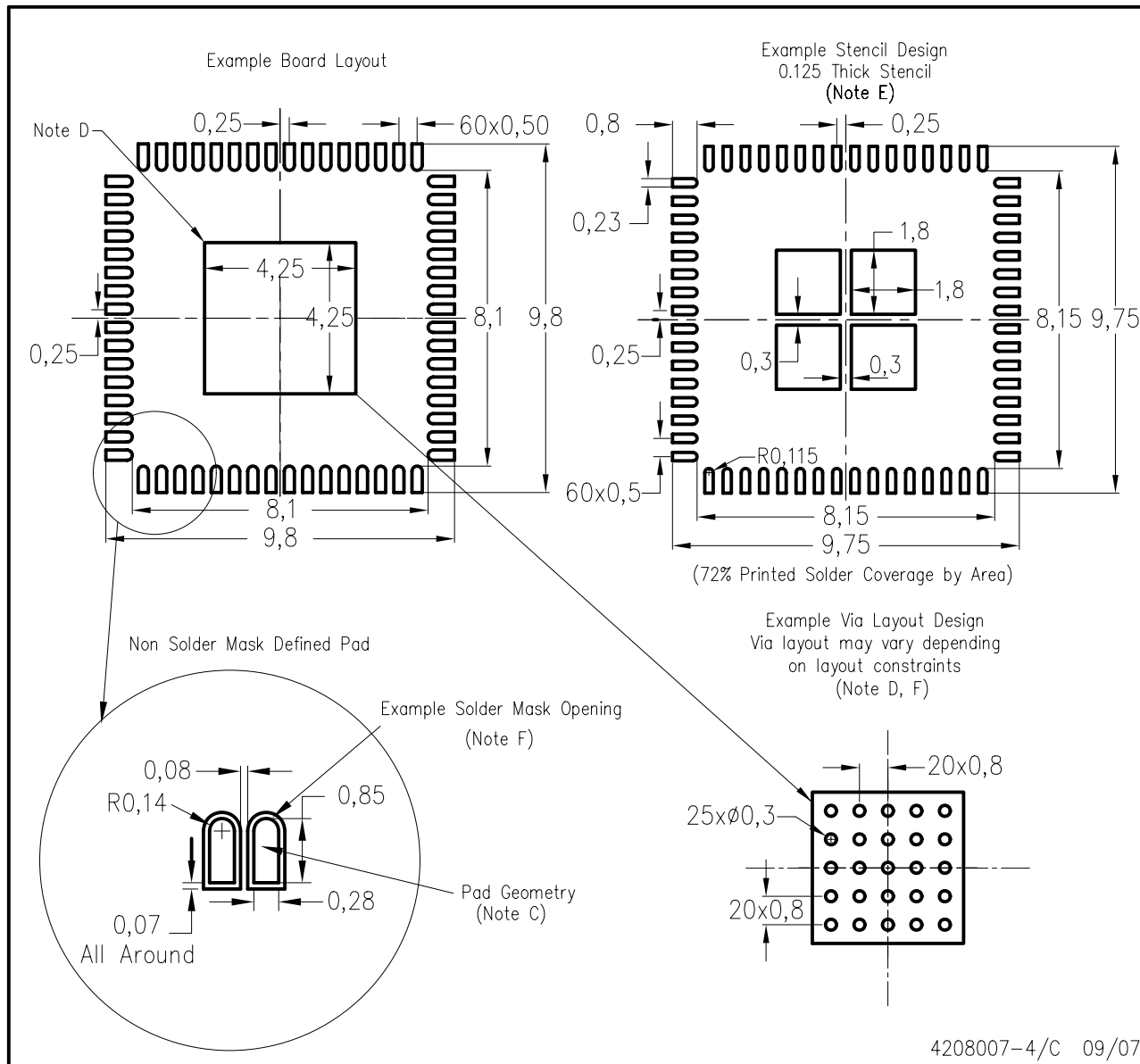

- NOTES:
- All linear dimensions are in millimeters.
 - This drawing is subject to change without notice.
 - Publication IPC-7351 is recommended for alternate designs.
 - This package is designed to be soldered to a thermal pad on the board. Refer to Application Note, Quad Flat-Pack Packages, Texas Instruments Literature No. SCBA017, SLUA271, and also the Product Data Sheets for specific thermal information, via requirements, and recommended board layout. These documents are available at www.ti.com <<http://www.ti.com>>.
 - Laser cutting apertures with trapezoidal walls and also rounding corners will offer better paste release. Customers should contact their board assembly site for stencil design recommendations. Refer to IPC 7525 for stencil design considerations.
 - Customers should contact their board fabrication site for recommended solder mask tolerances and via tenting recommendations for vias placed in thermal pad.

PACKAGING INFORMATION

Orderable Device	Status ⁽¹⁾	Package Type	Package Drawing	Pins	Package Qty	Eco Plan ⁽²⁾	Lead/Ball Finish	MSL Peak Temp ⁽³⁾
MSP430C413CY	ACTIVE					TBD	Call TI	Call TI
MSP430F412IPM	ACTIVE	LQFP	PM	64	160	Green (RoHS & no Sb/Br)	CU NIPDAU	Level-3-260C-168 HR
MSP430F412IPMR	ACTIVE	LQFP	PM	64	1000	Green (RoHS & no Sb/Br)	CU NIPDAU	Level-3-260C-168 HR
MSP430F412IRTDR	ACTIVE	QFN	RTD	64	2500	Green (RoHS & no Sb/Br)	CU SN	Level-3-260C-168 HR
MSP430F412IRTD	ACTIVE	QFN	RTD	64	250	Green (RoHS & no Sb/Br)	CU SN	Level-3-260C-168 HR
MSP430F413CY	ACTIVE					Green (RoHS & no Sb/Br)	Call TI	N / A for Pkg Type
MSP430F413IPM	ACTIVE	LQFP	PM	64	160	Green (RoHS & no Sb/Br)	CU NIPDAU	Level-3-260C-168 HR
MSP430F413IPMR	ACTIVE	LQFP	PM	64	1000	Green (RoHS & no Sb/Br)	CU NIPDAU	Level-3-260C-168 HR
MSP430F413IRTDR	ACTIVE	QFN	RTD	64	2500	TBD	Call TI	Call TI
MSP430F413IRTD	ACTIVE	QFN	RTD	64	250	Green (RoHS & no Sb/Br)	CU SN	Level-3-260C-168 HR
MSP430F415CY	ACTIVE					TBD	Call TI	Call TI
MSP430F415IPM	ACTIVE	LQFP	PM	64	160	Green (RoHS & no Sb/Br)	CU NIPDAU	Level-3-260C-168 HR
MSP430F415IPMR	ACTIVE	LQFP	PM	64	1000	Green (RoHS & no Sb/Br)	CU NIPDAU	Level-3-260C-168 HR
MSP430F415IRTDR	ACTIVE	QFN	RTD	64	2500	Green (RoHS & no Sb/Br)	CU SN	Level-3-260C-168 HR
MSP430F415IRTD	ACTIVE	QFN	RTD	64	250	Green (RoHS & no Sb/Br)	CU SN	Level-3-260C-168 HR
MSP430F417CY	ACTIVE					Green (RoHS & no Sb/Br)	Call TI	N / A for Pkg Type
MSP430F417IPM	ACTIVE	LQFP	PM	64	160	Green (RoHS & no Sb/Br)	CU NIPDAU	Level-3-260C-168 HR
MSP430F417IPMR	ACTIVE	LQFP	PM	64	1000	Green (RoHS & no Sb/Br)	CU NIPDAU	Level-3-260C-168 HR
MSP430F417IRTDR	ACTIVE	QFN	RTD	64	2500	Green (RoHS & no Sb/Br)	CU SN	Level-3-260C-168 HR
MSP430F417IRTD	ACTIVE	QFN	RTD	64	250	Green (RoHS & no Sb/Br)	CU SN	Level-3-260C-168 HR

⁽¹⁾ The marketing status values are defined as follows:

ACTIVE: Product device recommended for new designs.

LIFEBUY: TI has announced that the device will be discontinued, and a lifetime-buy period is in effect.

NRND: Not recommended for new designs. Device is in production to support existing customers, but TI does not recommend using this part in a new design.

PREVIEW: Device has been announced but is not in production. Samples may or may not be available.

OBSELETE: TI has discontinued the production of the device.

⁽²⁾ Eco Plan - The planned eco-friendly classification: Pb-Free (RoHS), Pb-Free (RoHS Exempt), or Green (RoHS & no Sb/Br) - please check <http://www.ti.com/productcontent> for the latest availability information and additional product content details.

TBD: The Pb-Free/Green conversion plan has not been defined.

Pb-Free (RoHS): TI's terms "Lead-Free" or "Pb-Free" mean semiconductor products that are compatible with the current RoHS requirements for all 6 substances, including the requirement that lead not exceed 0.1% by weight in homogeneous materials. Where designed to be soldered

at high temperatures, TI Pb-Free products are suitable for use in specified lead-free processes.

Pb-Free (RoHS Exempt): This component has a RoHS exemption for either 1) lead-based flip-chip solder bumps used between the die and package, or 2) lead-based die adhesive used between the die and leadframe. The component is otherwise considered Pb-Free (RoHS compatible) as defined above.

Green (RoHS & no Sb/Br): TI defines "Green" to mean Pb-Free (RoHS compatible), and free of Bromine (Br) and Antimony (Sb) based flame retardants (Br or Sb do not exceed 0.1% by weight in homogeneous material)

⁽³⁾ MSL, Peak Temp. -- The Moisture Sensitivity Level rating according to the JEDEC industry standard classifications, and peak solder temperature.

Important Information and Disclaimer:The information provided on this page represents TI's knowledge and belief as of the date that it is provided. TI bases its knowledge and belief on information provided by third parties, and makes no representation or warranty as to the accuracy of such information. Efforts are underway to better integrate information from third parties. TI has taken and continues to take reasonable steps to provide representative and accurate information but may not have conducted destructive testing or chemical analysis on incoming materials and chemicals. TI and TI suppliers consider certain information to be proprietary, and thus CAS numbers and other limited information may not be available for release.

In no event shall TI's liability arising out of such information exceed the total purchase price of the TI part(s) at issue in this document sold by TI to Customer on an annual basis.

PM (S-PQFP-G64)

PLASTIC QUAD FLATPACK

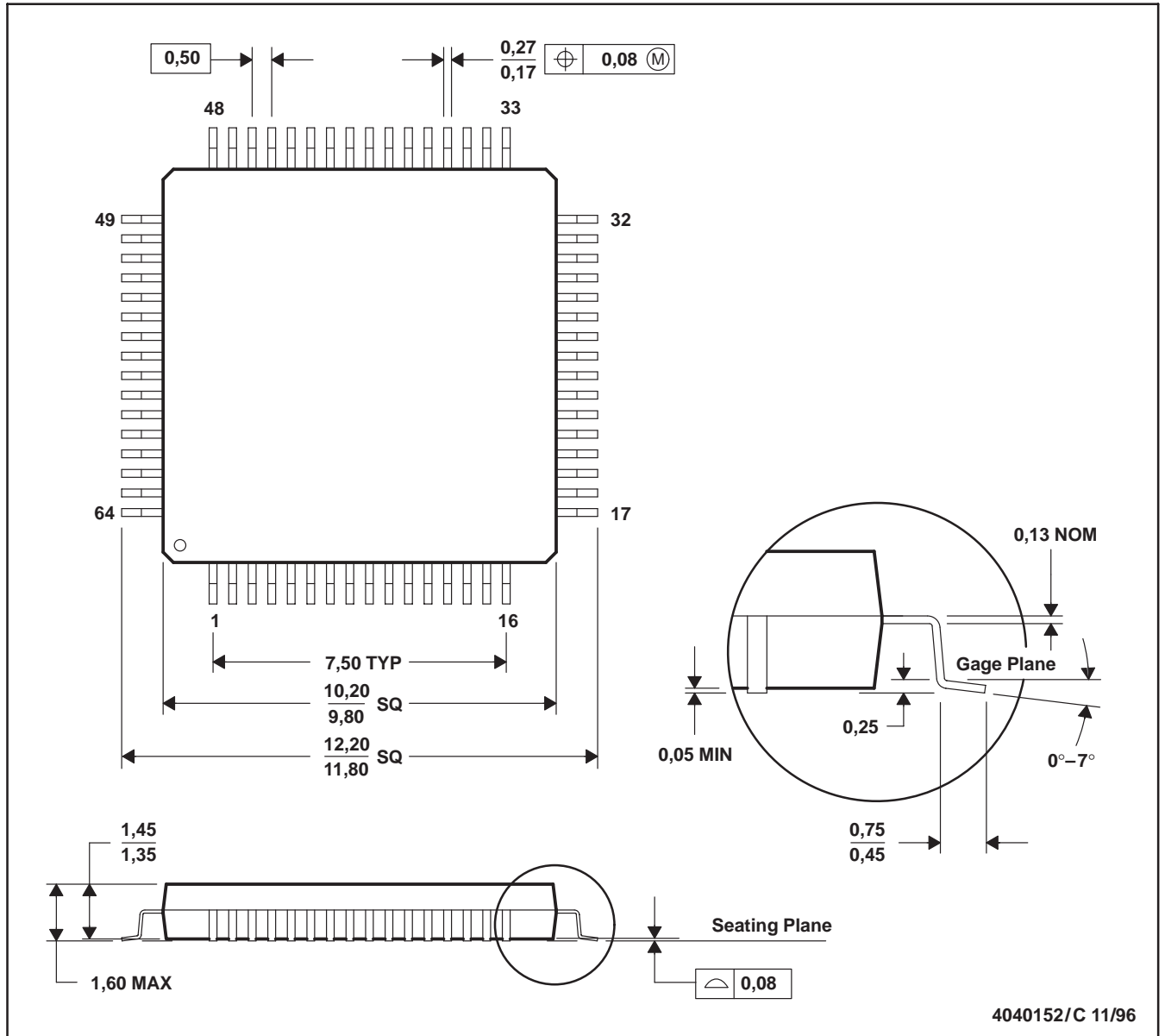

- NOTES: A. All linear dimensions are in millimeters.
 B. This drawing is subject to change without notice.
 C. Falls within JEDEC MS-026
 D. May also be thermally enhanced plastic with leads connected to the die pads.

RTD (S-PQFP-N64)

PLASTIC QUAD FLATPACK

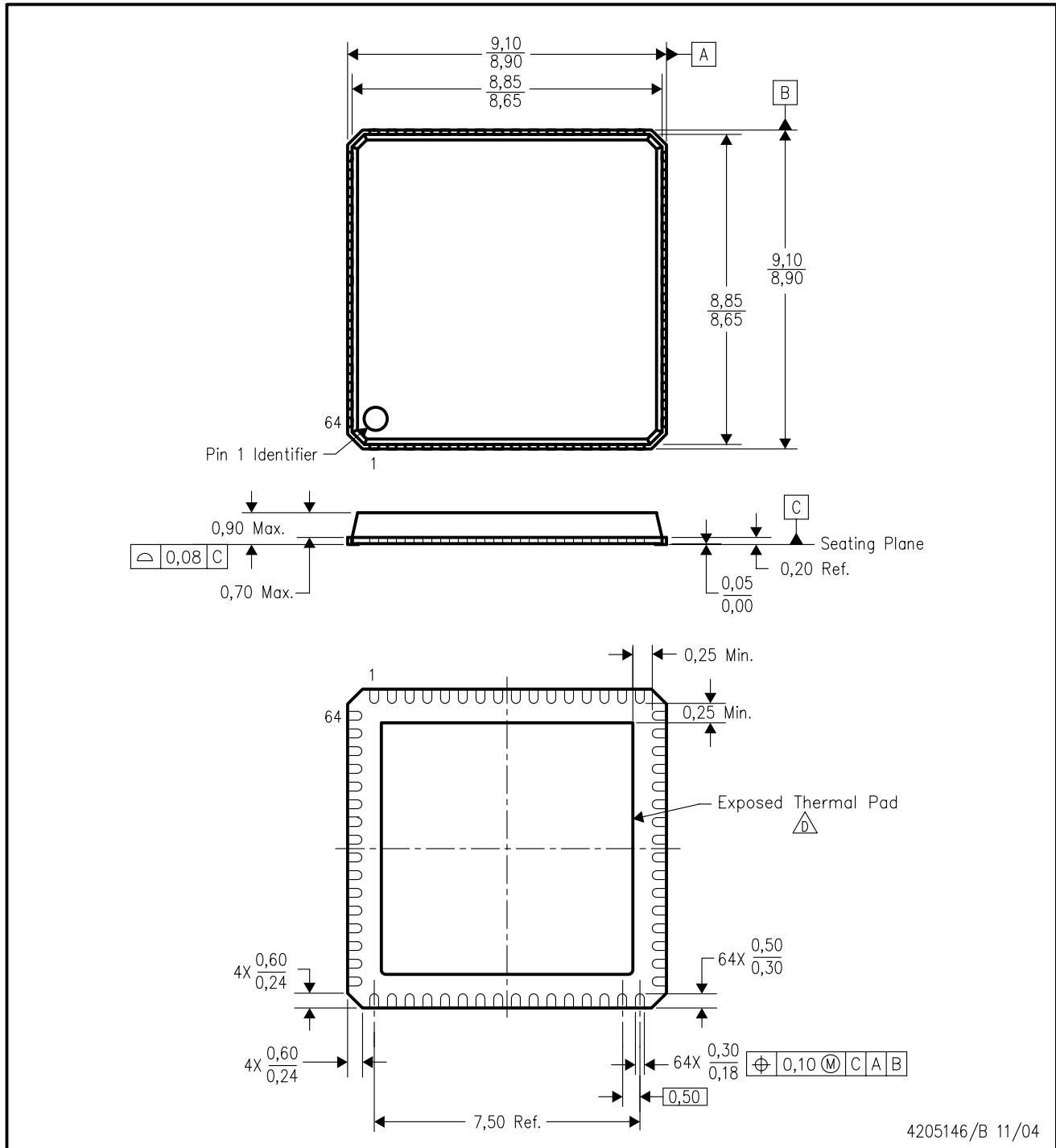

4205146/B 11/04

- NOTES:
- A. All linear dimensions are in millimeters. Dimensioning and tolerancing per ASME Y14.5M-1994.
 - B. This drawing is subject to change without notice.
 - C. QFN (Quad Flatpack No-Lead) Package configuration.
 -  The package thermal pad must be soldered to the board for thermal and mechanical performance. See the Product Data Sheet for details regarding the exposed thermal pad dimensions.

THERMAL INFORMATION

This package incorporates an exposed thermal pad that is designed to be attached directly to an external heatsink. The thermal pad must be soldered directly to the printed circuit board (PCB). After soldering, the PCB can be used as a heatsink. In addition, through the use of thermal vias, the thermal pad can be attached directly to the appropriate copper plane shown in the electrical schematic for the device, or alternatively, can be attached to a special heatsink structure designed into the PCB. This design optimizes the heat transfer from the integrated circuit (IC).

For information on the Quad Flatpack No-Lead (QFN) package and its advantages, refer to Application Report, Quad Flatpack No-Lead Logic Packages, Texas Instruments Literature No. SCBA017. This document is available at www.ti.com.

The exposed thermal pad dimensions for this package are shown in the following illustration.

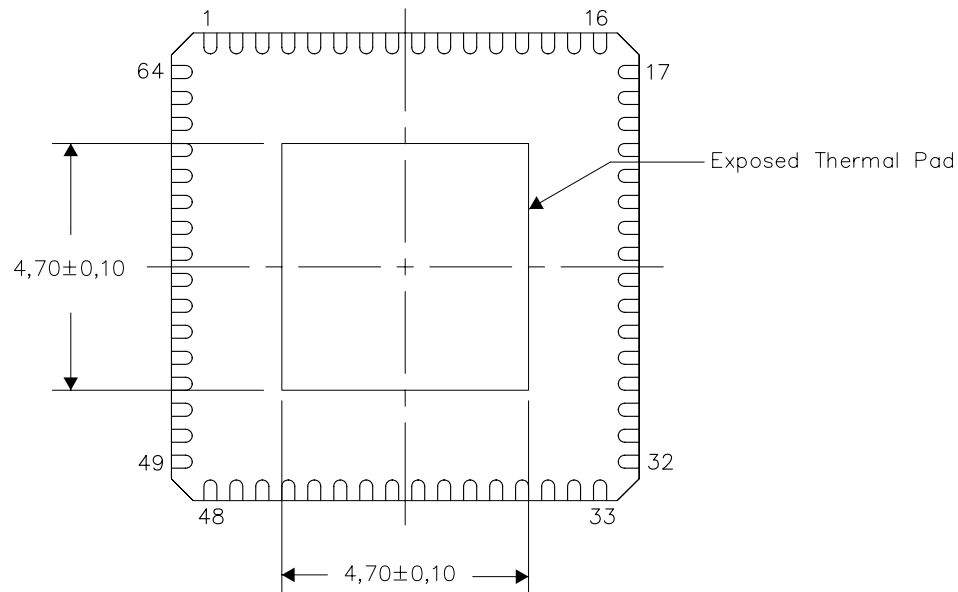

Bottom View

NOTE: All linear dimensions are in millimeters

Exposed Thermal Pad Dimensions

RTD (S-PQFP-N64)

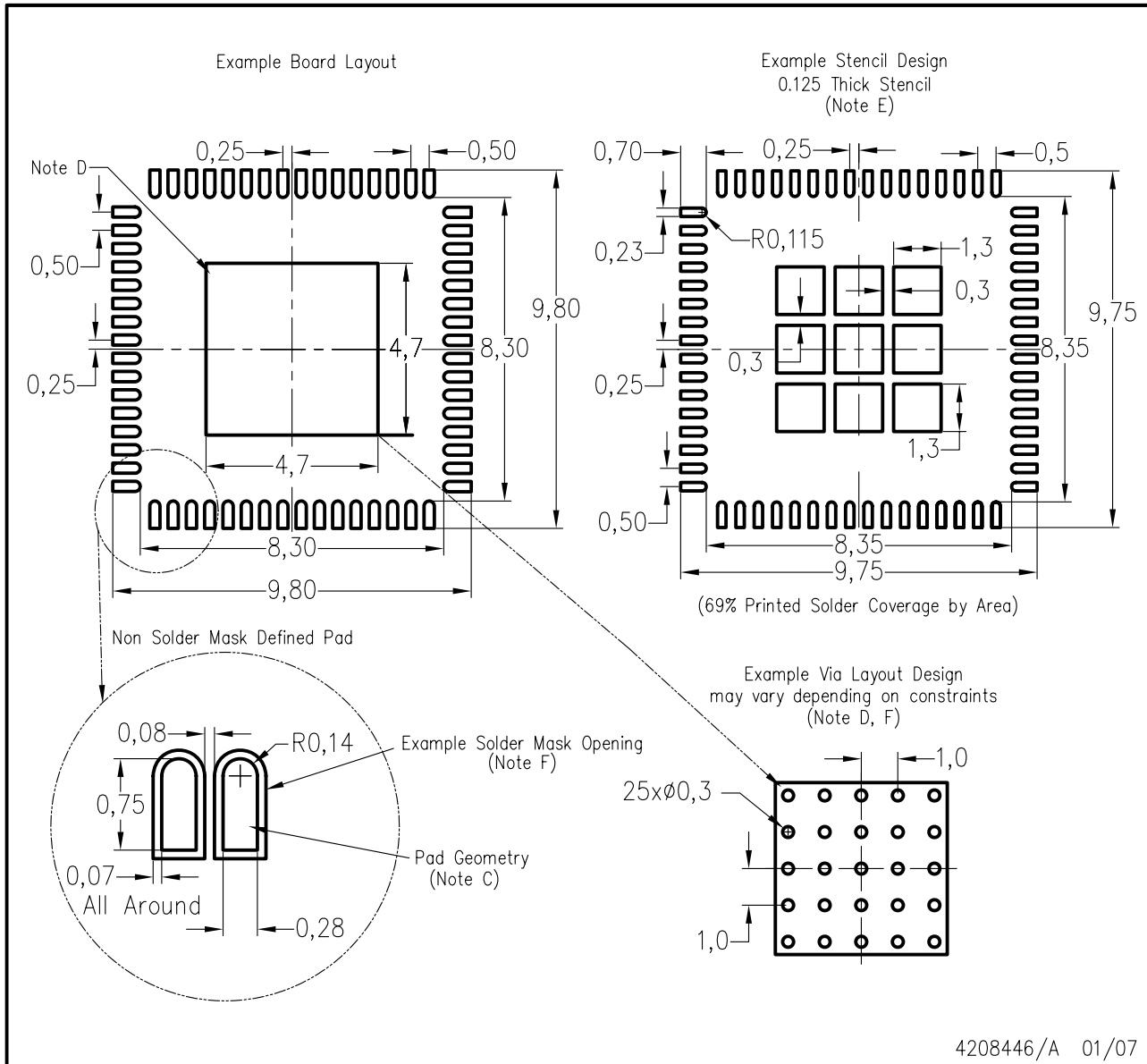

- NOTES:
- A. All linear dimensions are in millimeters.
 - B. This drawing is subject to change without notice.
 - C. Publication IPC-7351 is recommended for alternate designs.
 - D. This package is designed to be soldered to a thermal pad on the board. Refer to Application Note, Quad Flat-Pack Package, Texas Instruments Literature No. SCBA017 and SLUA271, and also the Product Data Sheets for specific thermal information, via requirements, and recommended board layout. These documents are available at www.ti.com <<http://www.ti.com>>.
 - E. Laser cutting apertures with electropolish and also rounding corners will offer better paste release. Customers should contact their board assembly site for stencil design recommendations. Refer to IPC 7525 for stencil design considerations.
 - F. Customer should contact their board fabrication site for recommended solder mask tolerances and vias tenting recommendations for vias placed into the thermal pad.

IMPORTANT NOTICE

Texas Instruments Incorporated and its subsidiaries (TI) reserve the right to make corrections, modifications, enhancements, improvements, and other changes to its products and services at any time and to discontinue any product or service without notice. Customers should obtain the latest relevant information before placing orders and should verify that such information is current and complete. All products are sold subject to TI's terms and conditions of sale supplied at the time of order acknowledgment.

TI warrants performance of its hardware products to the specifications applicable at the time of sale in accordance with TI's standard warranty. Testing and other quality control techniques are used to the extent TI deems necessary to support this warranty. Except where mandated by government requirements, testing of all parameters of each product is not necessarily performed.

TI assumes no liability for applications assistance or customer product design. Customers are responsible for their products and applications using TI components. To minimize the risks associated with customer products and applications, customers should provide adequate design and operating safeguards.

TI does not warrant or represent that any license, either express or implied, is granted under any TI patent right, copyright, mask work right, or other TI intellectual property right relating to any combination, machine, or process in which TI products or services are used. Information published by TI regarding third-party products or services does not constitute a license from TI to use such products or services or a warranty or endorsement thereof. Use of such information may require a license from a third party under the patents or other intellectual property of the third party, or a license from TI under the patents or other intellectual property of TI.

Reproduction of TI information in TI data books or data sheets is permissible only if reproduction is without alteration and is accompanied by all associated warranties, conditions, limitations, and notices. Reproduction of this information with alteration is an unfair and deceptive business practice. TI is not responsible or liable for such altered documentation. Information of third parties may be subject to additional restrictions.

Resale of TI products or services with statements different from or beyond the parameters stated by TI for that product or service voids all express and any implied warranties for the associated TI product or service and is an unfair and deceptive business practice. TI is not responsible or liable for any such statements.

TI products are not authorized for use in safety-critical applications (such as life support) where a failure of the TI product would reasonably be expected to cause severe personal injury or death, unless officers of the parties have executed an agreement specifically governing such use. Buyers represent that they have all necessary expertise in the safety and regulatory ramifications of their applications, and acknowledge and agree that they are solely responsible for all legal, regulatory and safety-related requirements concerning their products and any use of TI products in such safety-critical applications, notwithstanding any applications-related information or support that may be provided by TI. Further, Buyers must fully indemnify TI and its representatives against any damages arising out of the use of TI products in such safety-critical applications.

TI products are neither designed nor intended for use in military/aerospace applications or environments unless the TI products are specifically designated by TI as military-grade or "enhanced plastic." Only products designated by TI as military-grade meet military specifications. Buyers acknowledge and agree that any such use of TI products which TI has not designated as military-grade is solely at the Buyer's risk, and that they are solely responsible for compliance with all legal and regulatory requirements in connection with such use.

TI products are neither designed nor intended for use in automotive applications or environments unless the specific TI products are designated by TI as compliant with ISO/TS 16949 requirements. Buyers acknowledge and agree that, if they use any non-designated products in automotive applications, TI will not be responsible for any failure to meet such requirements.

Following are URLs where you can obtain information on other Texas Instruments products and application solutions:

Products

Amplifiers	amplifier.ti.com
Data Converters	dataconverter.ti.com
DSP	dsp.ti.com
Clocks and Timers	www.ti.com/clocks
Interface	interface.ti.com
Logic	logic.ti.com
Power Mgmt	power.ti.com
Microcontrollers	microcontroller.ti.com
RFID	www.ti-rfid.com
RF/IF and ZigBee® Solutions	www.ti.com/lprf

Applications

Audio	www.ti.com/audio
Automotive	www.ti.com/automotive
Broadband	www.ti.com/broadband
Digital Control	www.ti.com/digitalcontrol
Medical	www.ti.com/medical
Military	www.ti.com/military
Optical Networking	www.ti.com/opticalnetwork
Security	www.ti.com/security
Telephony	www.ti.com/telephony
Video & Imaging	www.ti.com/video
Wireless	www.ti.com/wireless

Mailing Address: Texas Instruments, Post Office Box 655303, Dallas, Texas 75265
Copyright © 2008, Texas Instruments Incorporated