

# MSP430F471x6, MSP430F471x7 MIXED SIGNAL MICROCONTROLLER

SLAS626A – OCTOBER 2008 – REVISED MAY 2009

- Low Supply-Voltage Range: 1.8 V to 3.6 V
- Ultralow Power Consumption
  - Active Mode: 350  $\mu$ A at 1 MHz, 2.2 V
  - Standby Mode: 1.1  $\mu$ A
  - Off Mode (RAM Retention): 0.2  $\mu$ A
- Five Power-Saving Modes
- Wake-Up From Standby Mode in Less Than 6  $\mu$ s
- 16-Bit RISC Architecture, 62.5-ns Instruction Cycle Time
- Three-Channel Internal DMA
- Six or Seven 16-Bit Sigma-Delta Analog-to-Digital (A/D) Converters With Differential PGA Inputs
- 16-Bit Timer\_B With Three Capture/Compare-With-Shadow Registers
- 16-Bit Timer\_A With Three Capture/Compare Registers
- On-Chip Comparator
- Four Universal Serial Communication Interface (USCI) Modules
  - USCI\_A0 and USCI\_A1
    - Enhanced UART Supporting Auto-Baudrate Detection
    - IrDA Encoder and Decoder
    - Synchronous SPI
  - USCI\_B0 and USCI\_B1
    - I2C
    - Synchronous SPI
- Integrated LCD Driver With Contrast Control for Up to 160 Segments
- Basic Timer With Real-Time Clock Feature
- 32-Bit Hardware Multiplier
- Brownout Detector
- Supply Voltage Supervisor/Monitor With Programmable Level Detection
- Serial Onboard Programming, No External Programming Voltage Needed
- Programmable Code Protection by Security Fuse
- Bootstrap Loader
- On-Chip Emulation Module
- Family Members Include
  - MSP430F47166: 92KB + 256B Flash  
4KB RAM  
6 Sigma-Delta ADCs
  - MSP430F47176: 92KB + 256B Flash  
8KB RAM  
6 Sigma-Delta ADCs
  - MSP430F47186: 116KB + 256B Flash  
8KB RAM  
6 Sigma-Delta ADCs
  - MSP430F47196: 120KB + 256B Flash  
4KB RAM  
6 Sigma-Delta ADCs
  - MSP430F47167: 92KB + 256B Flash  
4KB RAM  
7 Sigma-Delta ADCs
  - MSP430F47177: 92KB + 256B Flash  
8KB RAM  
7 Sigma-Delta ADCs
  - MSP430F47187: 116KB + 256B Flash  
8KB RAM  
7 Sigma-Delta ADCs
  - MSP430F47197: 120KB + 256B Flash  
4KB RAM  
7 Sigma-Delta ADCs
- Available in a 100-Pin Plastic Quad Flatpack (QFP) Package
- For Complete Module Descriptions, See the *MSP430x4xx Family User's Guide*, Literature Number SLAU056
- For E-Meter Reference Design and Software, See *Implementation of a Three-Phase Electronic Watt-Hour Meter using the MSP430F471xx*, Literature Number SLAA409



This integrated circuit can be damaged by ESD. Texas Instruments recommends that all integrated circuits be handled with appropriate precautions. Failure to observe proper handling and installation procedures can cause damage. ESD damage can range from subtle performance degradation to complete device failure. Precision integrated circuits may be more susceptible to damage because very small parametric changes could cause the device not to meet its published specifications. These devices have limited built-in ESD protection.



Please be aware that an important notice concerning availability, standard warranty, and use in critical applications of Texas Instruments semiconductor products and disclaimers thereto appears at the end of this data sheet.

PRODUCTION DATA information is current as of publication date. Products conform to specifications per the terms of Texas Instruments standard warranty. Production processing does not necessarily include testing of all parameters.



POST OFFICE BOX 655303 • DALLAS, TEXAS 75265

Copyright © 2009, Texas Instruments Incorporated

# MSP430F471x6, MSP430F471x7 MIXED SIGNAL MICROCONTROLLER

SLAS626A – OCTOBER 2008 – REVISED MAY 2009

## description

The Texas Instruments MSP430 family of ultralow-power microcontrollers consists of several devices featuring different sets of peripherals targeted for various applications. The architecture, combined with five low-power modes is optimized to achieve extended battery life in portable measurement applications. The device features a powerful 16-bit RISC CPU, 16-bit registers, and constant generators that contribute to maximum code efficiency. The digitally controlled oscillator (DCO) allows wake-up from low-power modes to active mode in less than 6 $\mu$ s.

The MSP430F471xx series are microcontroller configurations targeted to poly-phase electricity meters with six or seven 16-bit sigma-delta A/D converters. Each channel as a differential input pair and programmable input gain. Also integrated are two 16-bit timers, four universal serial communication interfaces (USCI), DMA, 68 I/O pins, and a liquid crystal driver (LCD) with integrated contrast control.

### AVAILABLE OPTIONS

T <sub>A</sub>	PACKAGED DEVICES
	PLASTIC 100-PIN QFP (PZ)
-40°C to 85°C	MSP430F47167IPZ
	MSP430F47177IPZ
	MSP430F47187IPZ
	MSP430F47197IPZ
	MSP430F47166IPZ
	MSP430F47176IPZ
	MSP430F47186IPZ
	MSP430F47196IPZ

† For the most current package and ordering information, see the Package Option Addendum at the end of this document, or see the TI web site at [www.ti.com](http://www.ti.com).

‡ Package drawings, thermal data, and symbolization are available at [www.ti.com/packaging](http://www.ti.com/packaging).

## DEVELOPMENT TOOL SUPPORT

All MSP430 microcontrollers include an Embedded Emulation Module (EEM) allowing advanced debugging and programming through easy to use development tools. Recommended hardware options include the following:

- Debugging and Programming Interface
  - MSP-FET430UIF (USB)
  - MSP-FET430PIF (Parallel Port)
- Debugging and Programming Interface with Target Board
  - MSP-FET430U100A
- Stand-Alone Target Board
  - MSP-TS430PZ100A
- Production Programmer
  - MSP-GANG430



POST OFFICE BOX 655303 • DALLAS, TEXAS 75265

# MSP430F471x6, MSP430F471x7 MIXED SIGNAL MICROCONTROLLER

SLAS626A – OCTOBER 2008 – REVISED MAY 2009

**functional block diagram, MSP430F471x7**

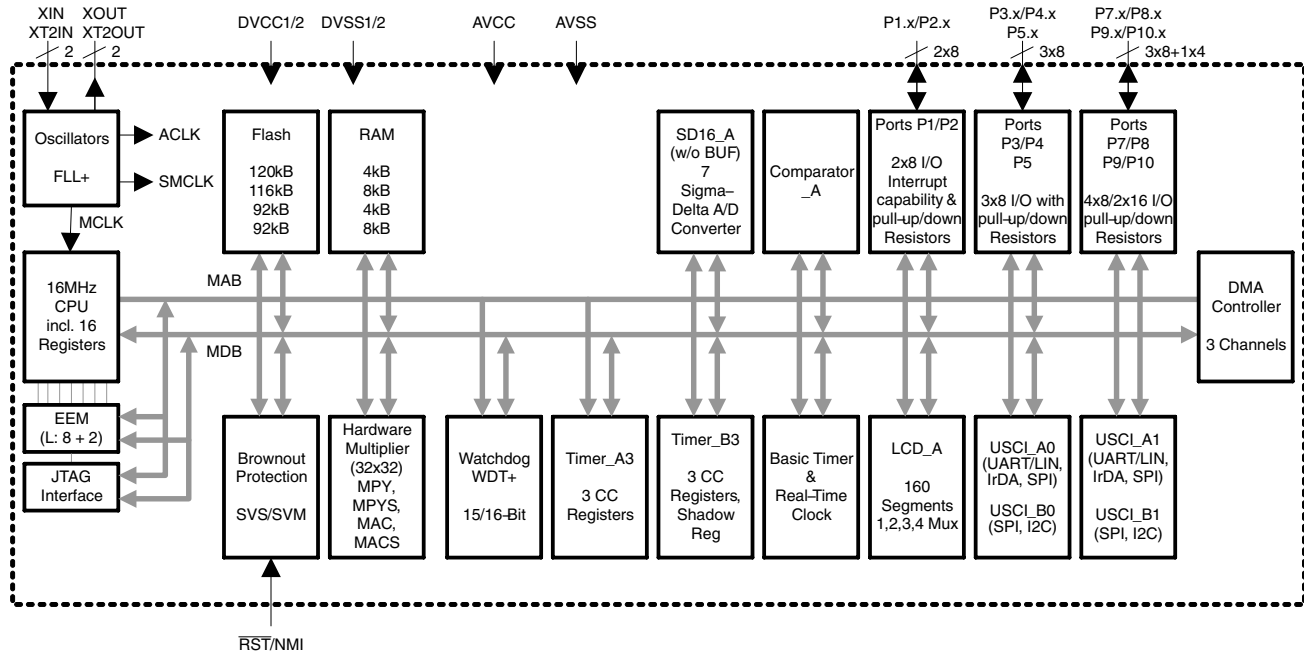

**functional block diagram, MSP430F471x6**

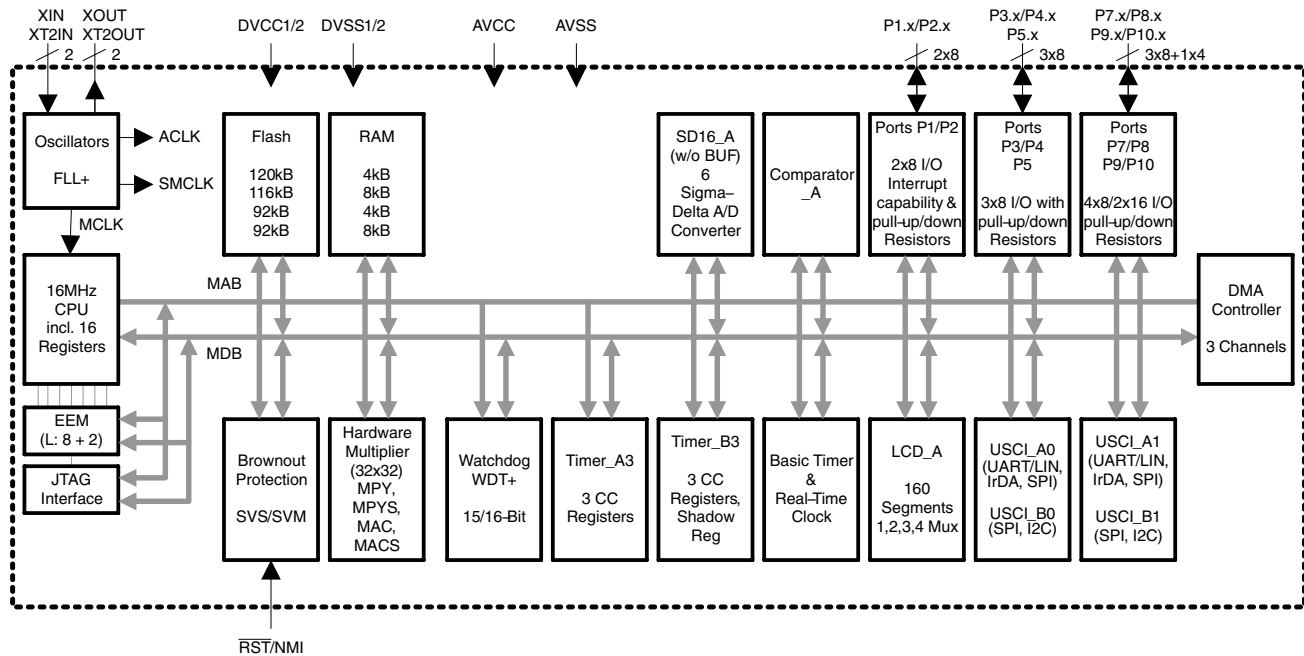

# MSP430F471x6, MSP430F471x7 MIXED SIGNAL MICROCONTROLLER

SLAS626A – OCTOBER 2008 – REVISED MAY 2009

## pin designation, MSP430F471x7IPZ

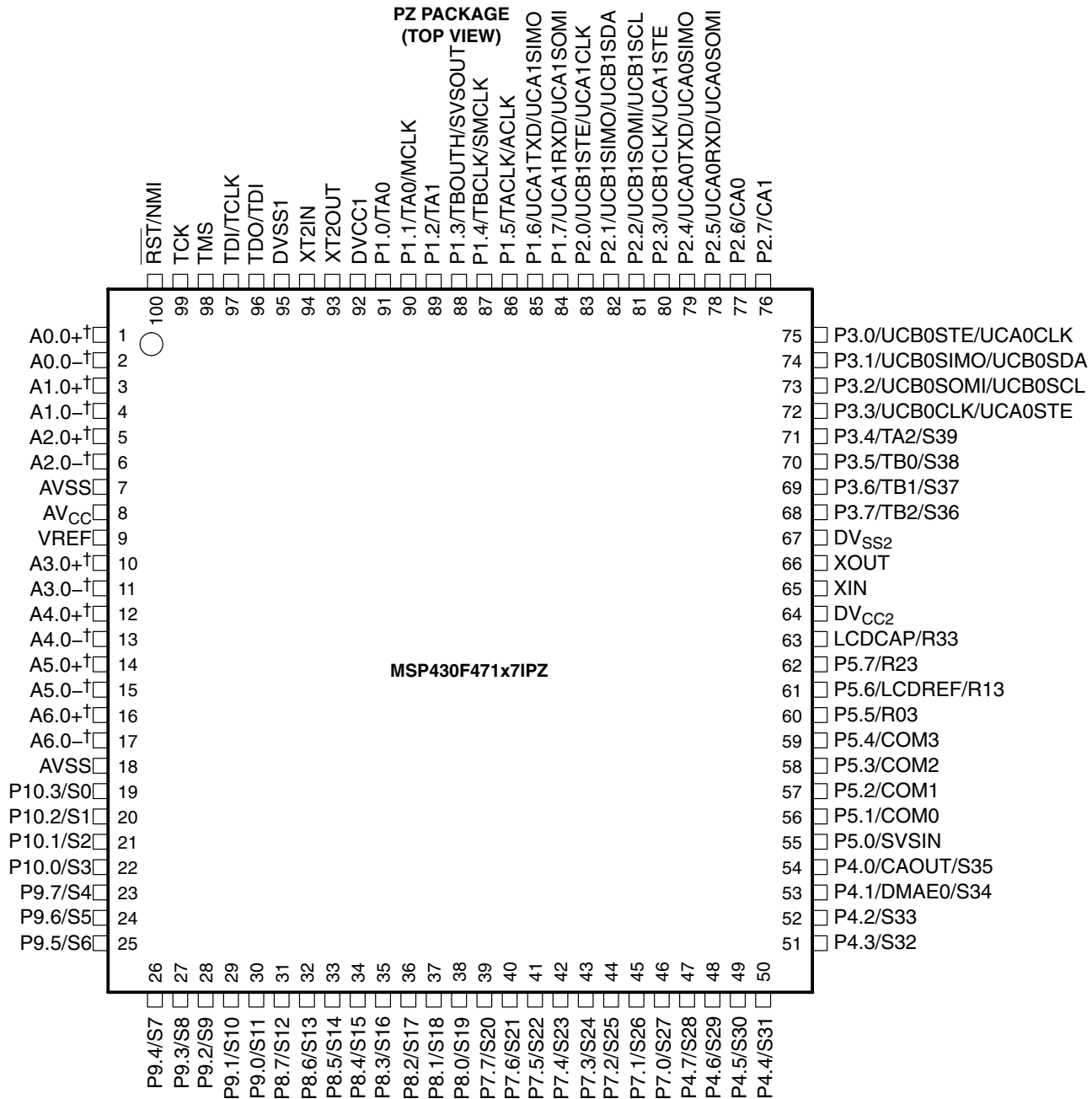

† It is recommended to short unused analog input pairs and connect them to analog ground.

## pin designation, MSP430F471x6IPZ

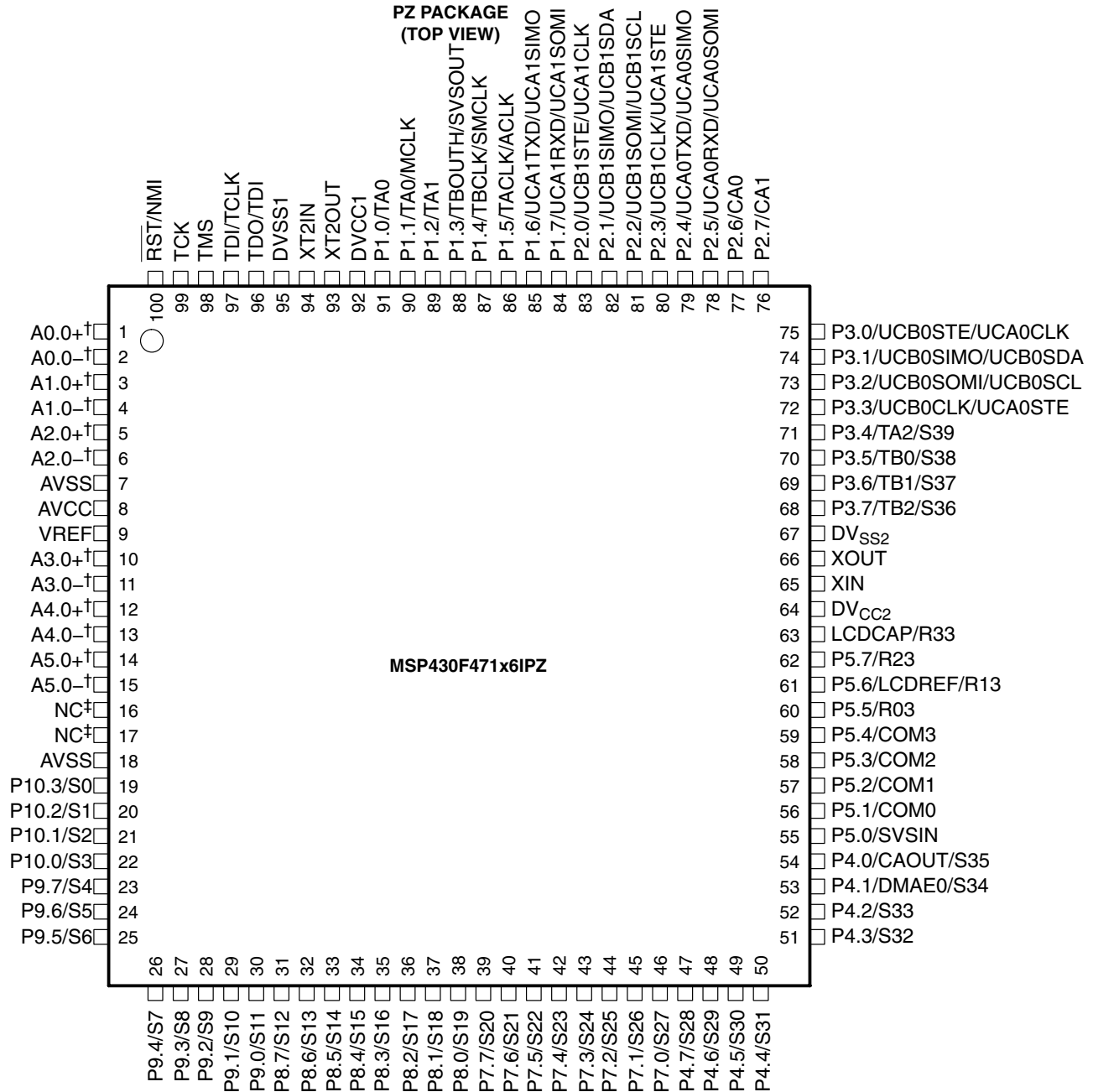

† It is recommended to short unused analog input pairs and connect them to analog ground.

‡ Connect pin to analog ground (AVSS).

# MSP430F471x6, MSP430F471x7 MIXED SIGNAL MICROCONTROLLER

SLAS626A – OCTOBER 2008 – REVISED MAY 2009

## Terminal Functions

TERMINAL NAME	NO.	I/O	DESCRIPTION
A0.0+	1	I	SD16_A positive analog input A0.0 (see Note 1)
A0.0-	2	I	SD16_A negative analog input A0.0 (see Note 1)
A1.0+	3	I	SD16_A positive analog input A1.0 (see Note 1)
A1.0-	4	I	SD16_A negative analog input A1.0 (see Note 1)
A2.0+	5	I	SD16_A positive analog input A2.0 (see Note 1)
A2.0-	6	I	SD16_A negative analog input A2.0 (see Note 1)
AV <sub>SS</sub>	7		Analog supply voltage, negative terminal.
AV <sub>CC</sub>	8		Analog supply voltage, positive terminal. Must not power up prior to DV <sub>CC1</sub> /DV <sub>CC2</sub> .
V <sub>REF</sub>	9	I/O	Input for an external reference voltage / internal reference voltage output (can be used as mid-voltage)
A3.0+	10	I	SD16_A positive analog input A3.0 (see Note 1)
A3.0-	11	I	SD16_A negative analog input A3.0 (see Note 1)
A4.0+	12	I	SD16_A positive analog input A4.0 (see Note 1)
A4.0-	13	I	SD16_A negative analog input A4.0 (see Note 1)
A5.0+	14	I	SD16_A positive analog input A5.0 (see Note 1)
A5.0-	15	I	SD16_A negative analog input A5.0 (see Note 1)
A6.0+ (MSP430F471x7 only)	16	I	SD16_A positive analog input A6.0 (see Note 1) – Not connected in MSP430F471x6, connect pin to analog ground (AV <sub>SS</sub> ).
A6.0- (MSP430F471x7 only)	17	I	SD16_A negative analog input A6.0 (see Note 1) – Not connected in MSP430F471x6, connect pin to analog ground (AV <sub>SS</sub> ).
AV <sub>SS</sub>	18		Analog supply voltage, negative terminal.
P10.3/S0	19	I/O	General-purpose digital I/O / LCD segment output 0
P10.2/S1	20	I/O	General-purpose digital I/O / LCD segment output 1
P10.1/S2	21	I/O	General-purpose digital I/O / LCD segment output 2
P10.0/S3	22	I/O	General-purpose digital I/O / LCD segment output 3
P9.7/S4	23	I/O	General-purpose digital I/O / LCD segment output 4
P9.6/S5	24	I/O	General-purpose digital I/O / LCD segment output 5
P9.5/S6	25	I/O	General-purpose digital I/O / LCD segment output 6
P9.4/S7	26	I/O	General-purpose digital I/O / LCD segment output 7
P9.3/S8	27	I/O	General-purpose digital I/O / LCD segment output 8
P9.2/S9	28	I/O	General-purpose digital I/O / LCD segment output 9
P9.1/S10	29	I/O	General-purpose digital I/O / LCD segment output 10
P9.0/S11	30	I/O	General-purpose digital I/O / LCD segment output 11
P8.7/S12	31	I/O	General-purpose digital I/O / LCD segment output 12
P8.6/S13	32	I/O	General-purpose digital I/O / LCD segment output 13
P8.5/S14	33	I/O	General-purpose digital I/O / LCD segment output 14
P8.4/S15	34	I/O	General-purpose digital I/O / LCD segment output 15
P8.3/S16	35	I/O	General-purpose digital I/O / LCD segment output 16
P8.2/S17	36	I/O	General-purpose digital I/O / LCD segment output 17
P8.1/S18	37	I/O	General-purpose digital I/O / LCD segment output 18
P8.0/S19	38	I/O	General-purpose digital I/O / LCD segment output 19
P7.7/S20	39	I/O	General-purpose digital I/O / LCD segment output 20
P7.6/S21	40	I/O	General-purpose digital I/O / LCD segment output 21

NOTES: 1. It is recommended to short unused analog input pairs and connect them to analog ground.



**Terminal Functions (continued)**

<b>TERMINAL NAME</b>	<b>NO.</b>	<b>I/O</b>	<b>DESCRIPTION</b>
P7.5/S22	41	I/O	General-purpose digital I/O / LCD segment output 22
P7.4/S23	42	I/O	General-purpose digital I/O / LCD segment output 23
P7.3/S24	43	I/O	General-purpose digital I/O / LCD segment output 24
P7.2/S25	44	I/O	General-purpose digital I/O / LCD segment output 25
P7.1/S26	45	I/O	General-purpose digital I/O / LCD segment output 26
P7.0/S27	46	I/O	General-purpose digital I/O / LCD segment output 27
P4.7/S28	47	I/O	General-purpose digital I/O / LCD segment output 28
P4.6/S29	48	I/O	General-purpose digital I/O / LCD segment output 29
P4.5/S30	49	I/O	General-purpose digital I/O / LCD segment output 30
P4.4/S31	50	I/O	General-purpose digital I/O / LCD segment output 31
P4.3/S32	51	I/O	General-purpose digital I/O / LCD segment output 32
P4.2/S33	52	I/O	General-purpose digital I/O / LCD segment output 33
P4.1/DMAE0/S34	53	I/O	General-purpose digital I/O / DMA Channel 0 external trigger / LCD segment output 34
P4.0/CAOUT/S35	54	I/O	General-purpose digital I/O / Comparator_A output / LCD segment output 35
P5.0/SVSIN	55	I/O	General-purpose digital I/O / analog input to supply voltage supervisor
P5.1/COM0	56	I/O	General-purpose digital I/O / common output, COM0–3 are used for LCD backplanes.
P5.2/COM1	57	I/O	General-purpose digital I/O / common output, COM0–3 are used for LCD backplanes.
P5.3/COM2	58	I/O	General-purpose digital I/O / common output, COM0–3 are used for LCD backplanes.
P5.4/COM3	59	I/O	General-purpose digital I/O / common output, COM0–3 are used for LCD backplanes.
P5.5/R03	60	I/O	General-purpose digital I/O / Input port of lowest analog LCD level (V5)
P5.6/LCDREF/R13	61	I/O	General-purpose digital I/O / External reference voltage input for regulated LCD voltage / Input port of third most positive analog LCD level (V4 or V3)
P5.7/R23	62	I/O	General-purpose digital I/O / Input port of second most positive analog LCD level (V2)
LCDCAP/R33	63	I	LCD Capacitor connection / Input/output port of most positive analog LCD level (V1)
DV <sub>CC2</sub>	64		Digital supply voltage, positive terminal.
XIN	65	I	Input port for crystal oscillator XT1. Standard or watch crystals can be connected.
XOUT	66	O	Output terminal of crystal oscillator XT1
DV <sub>SS2</sub>	67		Digital supply voltage, negative terminal.
P3.7/TB2/S36	68	I/O	General-purpose digital I/O / Timer_B3 CCR2. Capture: CCI2A/CCI2B input, compare: Out2 output / LCD segment output 36
P3.6/TB1/S37	69	I/O	General-purpose digital I/O / Timer_B3 CCR1. Capture: CCI1A/CCI1B input, compare: Out1 output / LCD segment output 37
P3.5/TB0/S38	70	I/O	General-purpose digital I/O / Timer_B3 CCR0. Capture: CCI0A/CCI0B input, compare: Out0 output / LCD segment output 38
P3.4/TA2/S39	71	I/O	General-purpose digital I/O / Timer_A Capture: CCI2A input, compare: Out2 output / LCD segment output 39
P3.3/ UCB0CLK/UCA0STE	72	I/O	General-purpose digital I/O / USCI_B0 clock input/output / USCI_A0 slave transmit enable
P3.2/ UCB0SOMI/UCB0SCL	73	I/O	General-purpose digital I/O / USCI_B1 slave out/master in in SPI mode, SCL I <sup>2</sup> C clock in I <sup>2</sup> C mode
P3.1/ UCB0SIMO/UCB0SDA	74	I/O	General-purpose digital I/O / USCI_B1 slave in/master out in SPI mode, SDA I <sup>2</sup> C data in I <sup>2</sup> C mode
P3.0/ UCB0STE/UCA0CLK	75	I/O	General-purpose digital I/O / USCI_B0 slave transmit enable / USCI_A0 clock input/output
P2.7/CA1	76	I/O	General-purpose digital I/O / Comparator_A input
P2.6/CA0	77	I/O	General-purpose digital I/O / Comparator_A input

# MSP430F471x6, MSP430F471x7 MIXED SIGNAL MICROCONTROLLER

SLAS626A – OCTOBER 2008 – REVISED MAY 2009

## Terminal Functions (continued)

TERMINAL NAME	NO.	I/O	DESCRIPTION
P2.5/ UCA0RXD/UCA0SOMI	78	I/O	General-purpose digital I/O / USCI_A0 receive data input in UART mode, slave out/master in in SPI mode
P2.4/ UCA0TXD/UCA0SIMO	79	I/O	General-purpose digital I/O / USCI_A0 transmit data output in UART mode, slave in/master out in SPI mode
P2.3/ UCB1CLK/UCA1STE	80	I/O	General-purpose digital I/O / USCI_B1 clock input/output / USCI_A1 slave transmit enable
P2.2/ UCB1SOMI/UCB1SCL	81	I/O	General-purpose digital I/O / USCI_B1 slave out/master in in SPI mode, SCL I <sup>2</sup> C clock in I <sup>2</sup> C mode
P2.1/ UCB1SIMO/UCB1SDA	82	I/O	General-purpose digital I/O / USCI_B1 slave in/master out in SPI mode, SDA I <sup>2</sup> C data in I <sup>2</sup> C mode
P2.0/ UCB1STE/UCA1CLK	83	I/O	General-purpose digital I/O / USCI_B1 slave transmit enable / USCI_A1 clock input/output
P1.7/ UCA1RXD/UCA1SOMI	84	I/O	General-purpose digital I/O / USCI_A1 receive data input in UART mode, slave out/master in in SPI mode
P1.6/ UCA1TXD/UCA1SIMO	85	I/O	General-purpose digital I/O / USCI_A1 transmit data output in UART mode, slave in/master out in SPI mode
P1.5/TACLK/ACLK	86	I/O	General-purpose digital I/O / Timer_A, clock signal TACLK input / ACLK output (divided by 1, 2, 4, or 8)
P1.4/TBCLK/SMCLK	87	I/O	General-purpose digital I/O / input clock TBCLK—Timer_B3 / submain system clock SMCLK output
P1.3/TBOUTH/SVSOUT	88	I/O	General-purpose digital I/O / switch all PWM digital output ports to high impedance—Timer_B3 TB0 to TB2 / SVS: output of SVS comparator
P1.2/TA1	89	I/O	General-purpose digital I/O / Timer_A, Capture: CCI1A input, compare: Out1 output
P1.1/TA0/MCLK	90	I/O	General-purpose digital I/O / Timer_A. Capture: CCI0B input / MCLK output. Note: TA0 is only an input on this pin / BSL receive
P1.0/TA0	91	I/O	General-purpose digital I/O / Timer_A. Capture: CCI0A input, compare: Out0 output / BSL transmit
DV <sub>CC1</sub>	92		Digital supply voltage, positive terminal.
XT2OUT	93	O	Output terminal of crystal oscillator XT2
XT2IN	94	I	Input port for crystal oscillator XT2. Only standard crystals can be connected.
DV <sub>SS1</sub>	95		Digital supply voltage, negative terminal.
TDO/TDI	96	I/O	Test data output port. TDO/TDI data output or programming data input terminal
TDI/TCLK	97	I	Test data input or test clock input. The device protection fuse is connected to TDI/TCLK.
TMS	98	I	Test mode select. TMS is used as an input port for device programming and test.
TCK	99	I	Test clock. TCK is the clock input port for device programming and test.
RST/NMI	100	I	Reset input or nonmaskable interrupt input port





## short-form description

### CPU

The MSP430 CPU has a 16-bit RISC architecture that is highly transparent to the application. All operations, other than program-flow instructions, are performed as register operations in conjunction with seven addressing modes for source operand and four addressing modes for destination operand.

The CPU is integrated with 16 registers that provide reduced instruction execution time. The register-to-register operation execution time is one cycle of the CPU clock.

Four of the registers, R0 to R3, are dedicated as program counter, stack pointer, status register, and constant generator, respectively. The remaining registers are general-purpose registers.

Peripherals are connected to the CPU using data, address, and control buses and can be handled with all instructions.

Program Counter	PC/R0
Stack Pointer	SP/R1
Status Register	SR/CG1/R2
Constant Generator	CG2/R3
General-Purpose Register	R4
General-Purpose Register	R5
General-Purpose Register	R6
General-Purpose Register	R7
General-Purpose Register	R8
General-Purpose Register	R9
General-Purpose Register	R10
General-Purpose Register	R11
General-Purpose Register	R12
General-Purpose Register	R13
General-Purpose Register	R14
General-Purpose Register	R15

### instruction set

The instruction set consists of 51 instructions with three formats and seven address modes. Each instruction can operate on word and byte data. Table 1 shows examples of the three types of instruction formats; Table 2 shows the address modes.

**Table 1. Instruction Word Formats**

Dual operands, source-destination	e.g., ADD R4,R5	R4 + R5 ----> R5
Single operands, destination only	e.g., CALL R8	PC ---->(TOS), R8----> PC
Relative jump, un/conditional	e.g., JNE	Jump-on-equal bit = 0

**Table 2. Address Mode Descriptions**

ADDRESS MODE	S	D	SYNTAX	EXAMPLE	OPERATION
Register	●	●	MOV Rs,Rd	MOV R10,R11	R10 --> R11
Indexed	●	●	MOV X(Rn),Y(Rm)	MOV 2(R5),6(R6)	M(2+R5)----> M(6+R6)
Symbolic (PC relative)	●	●	MOV EDE,TONI		M(EDE) --> M(TONI)
Absolute	●	●	MOV &MEM,&TCDAT		M(MEM) --> M(TCDAT)
Indirect	●		MOV @Rn,Y(Rm)	MOV @R10,Tab(R6)	M(R10) --> M(Tab+R6)
Indirect autoincrement	●		MOV @Rn+,Rm	MOV @R10+,R11	M(R10) --> R11 R10 + 2----> R10
Immediate	●		MOV #X,TONI	MOV #45,TONI	#45 --> M(TONI)

NOTE: S = source, D = destination

# MSP430F471x6, MSP430F471x7 MIXED SIGNAL MICROCONTROLLER

SLAS626A – OCTOBER 2008 – REVISED MAY 2009

---

## operating modes

The MSP430 has one active mode and five software-selectable low-power modes of operation. An interrupt event can wake up the device from any of the five low-power modes, service the request, and restore back to the low-power mode on return from the interrupt program.

The following six operating modes can be configured by software:

- Active mode AM
  - All clocks are active
- Low-power mode 0 (LPM0)
  - CPU is disabled
  - ACLK and SMCLK remain active. MCLK is disabled.
  - FLL+ loop control remains active
- Low-power mode 1 (LPM1)
  - CPU is disabled
  - FLL+ loop control is disabled
  - ACLK and SMCLK remain active. MCLK is disabled.
- Low-power mode 2 (LPM2)
  - CPU is disabled
  - MCLK and FLL+ loop control and DCOCLK are disabled
  - DCO's dc generator remains enabled
  - ACLK remains active
- Low-power mode 3 (LPM3)
  - CPU is disabled
  - MCLK, FLL+ loop control, and DCOCLK are disabled
  - DCO's dc generator is disabled
  - ACLK remains active
- Low-power mode 4 (LPM4)
  - CPU is disabled
  - ACLK is disabled
  - MCLK, FLL+ loop control, and DCOCLK are disabled
  - DCO's dc generator is disabled
  - Crystal oscillator is stopped



## interrupt vector addresses

The interrupt vectors and the power-up starting address are located in the address range 0FFFFh to 0FFC0h. The vector contains the 16-bit address of the appropriate interrupt-handler instruction sequence. If the reset vector (at 0FFFEh) contains 0FFFFh (e.g., flash is not programmed) the CPU enters LPM4 after power-up.

INTERRUPT SOURCE	INTERRUPT FLAG	SYSTEM INTERRUPT	WORD ADDRESS	PRIORITY
Power-Up External Reset Watchdog Flash Memory PC Out-of-Range (see Note 4)	PORIFG RSTIFG WDTIFG KEYV (see Note 1)	Reset	0FFFEh	31, highest
NMI Oscillator Fault Flash Memory Access Violation	NMIIFG (see Notes 1 and 3) OFIFG (see Notes 1 and 3) ACCVIFG (see Notes 1 and 3)	(Non)maskable (Non)maskable (Non)maskable	0FFFCh	30
Timer_B3	TBCCR0 CCIFG (see Note 2)	Maskable	0FFFAh	29
Timer_B3	TBCCR1 to TBCCR2 CCIFGs TBIFG (see Notes 1 and 2)	Maskable	0FFF8h	28
Comparator_A	CAIFG	Maskable	0FFF6h	27
Watchdog Timer	WDTIFG	Maskable	0FFF4h	26
USCI_A0/B0 Receive USCI_B0 I2C Status	UCA0RXIFG, UCB0RXIFG (see Notes 1 and 5)	Maskable	0FFF2h	25
USCI_A0/B0 Transmit USCI_B0 I2C Receive/Transmit	UCA0TXIFG, UCB0TXIFG (see Notes 1 and 6)	Maskable	0FFF0h	24
SD16_A	SD16CCTLx SD16OVIFG, SD16CCTLx SD16IFG (see Notes 1 and 2)	Maskable	0FFEEh	23
Timer_A3	TACCR0 CCIFG (see Note 2)	Maskable	0FFECh	22
Timer_A3	TACCR1 and TACCR2 CCIFGs, TAIFG (see Notes 1 and 2)	Maskable	0FFEAh	21
I/O Port P1 (Eight Flags)	P1IFG.0 to P1IFG.7 (see Notes 1 and 2)	Maskable	0FFE8h	20
USCI_A1/B1 Receive USCI_B1 I2C Status	UCA1RXIFG, UCB1RXIFG (see Notes 1 and 5)	Maskable	0FFE6h	19
USCI_A1/B1 Transmit USCI_B1 I2C Receive/Transmit	UCA1TXIFG, UCB1TXIFG (see Notes 1 and 6)	Maskable	0FFE4h	18
I/O Port P2 (Eight Flags)	P2IFG.0 to P2IFG.7 (see Notes 1 and 2)	Maskable	0FFE2h	17
Basic Timer1/RTC	BTIFG	Maskable	0FFE0h	16
DMA	DMA0IFG, DMA1IFG, DMA2IFG (see Notes 1 and 2)	Maskable	0FFDEh	15
Reserved	Reserved (see Note 8)		0FFDCh to	14 to
			0FFC0h	0, lowest

- NOTES:
- Multiple source flags
  - Interrupt flags are located in the module.
  - (Non)maskable: the individual interrupt-enable bit can disable an interrupt event, but the general-interrupt enable can not disable it.
  - A reset is generated if the CPU tries to fetch instructions from within the module register memory address range (0h to 01FFh) or from within unused address ranges.
  - USCI\_B in SPI mode: UCBxRXIFG. USCI\_B in I2C mode: UCALIFG, UCNACKIFG, ICSTTIFG, UCSTPIFG
  - USCI\_B in SPI mode: UCBxTXIFG. USCI\_B in I2C mode: UCBxRXIFG, UCBxTXIFG
  - The address 0x0FFBE is used as bootstrap loader security key (BSLSKEY).  
A 0x0AA55 at this location disables the BSL completely.  
A zero disables the erasure of the flash if an invalid password is supplied.
  - The interrupt vectors at addresses 0FFDCh to 0FFC0h are not used in this device and can be used for regular program code if necessary.

# MSP430F471x6, MSP430F471x7 MIXED SIGNAL MICROCONTROLLER

SLAS626A – OCTOBER 2008 – REVISED MAY 2009

## special function registers

The MSP430 special function registers (SFR) are located in the lowest address space and are organized as byte mode registers. SFRs should be accessed with byte instructions.

### interrupt enable 1 and 2

Address	7	6	5	4	3	2	1	0
00h			ACCVIE	NMIIE			OFIE	WDTIE
			rw-0	rw-0			rw-0	rw-0

WDTIE Watchdog timer interrupt enable. Inactive if watchdog mode is selected. Active if watchdog timer is configured in interval timer mode.

OFIE Oscillator fault enable

NMIIE (Non)maskable interrupt enable

ACCVIE Flash access violation interrupt enable

Address	7	6	5	4	3	2	1	0
01h	BTIE				UCB0TXIE	UCB0RXIE	UCA0TXIE	UCA0RXIE
	rw-0				rw-0	rw-0	rw-0	rw-0

UCA0RXIE USCI\_A0 receive interrupt enable

UCA0TXIE USCI\_A0 transmit interrupt enable

UCB0RXIE USCI\_B0 receive interrupt enable

UCB0TXIE USCI\_B0 transmit interrupt enable

BTIE Basic timer interrupt enable

interrupt flag register 1 and 2

Address	7	6	5	4	3	2	1	0
02h				NMIIFG	RSTIFG	PORIFG	OFIFG	WDTIFG
				rw-0	rw-(0)	rw-(1)	rw-1	rw-(0)

- WDTIFG Set on watchdog timer overflow or security key violation.  
Reset on V<sub>CC</sub> power-up or a reset condition at  $\overline{\text{RST}}$ /NMI pin in reset mode.
- OFIFG Flag set on oscillator fault
- RSTIFG External reset interrupt flag. Set on a reset condition at  $\overline{\text{RST}}$ /NMI pin in reset mode. Reset on V<sub>CC</sub> power-up
- PORIFG Power-on interrupt flag. Set on V<sub>CC</sub> power-up.
- NMIIFG Set via  $\overline{\text{RST}}$ /NMI-pin

Address	7	6	5	4	3	2	1	0
03h	BTIFG				UCB0 TXIFG	UCB0 RXIFG	UCA0 TXIFG	UCA0 RXIFG
	rw-0				rw-1	rw-0	rw-1	rw-0

- UCA0RXIFG USCI\_A0 receive interrupt flag
- UCA0TXIFG USCI\_A0 transmit interrupt flag
- UCB0RXIFG USCI\_B0 receive interrupt flag
- UCB0TXIFG USCI\_B0 transmit interrupt flag
- BTIFG Basic Timer1 interrupt flag

- Legend** rw: Bit can be read and written.  
 rw-0,1: Bit can be read and written. It is Reset or Set by PUC.  
 rw-(0,1): Bit can be read and written. It is Reset or Set by POR.

SFR bit is not present in device

# MSP430F471x6, MSP430F471x7 MIXED SIGNAL MICROCONTROLLER

SLAS626A – OCTOBER 2008 – REVISED MAY 2009

## memory organization

		MSP430F47166/ MSP430F47167	MSP430F47176/ MSP430F47177	MSP430F47186 MSP430F47187	MSP430F47196 MSP430F47197
Memory Main: interrupt vector Main: code memory	Size	92KB	92KB	116KB	120KB
	Flash Flash	0FFFFh – 0FFC0h 018FFFh – 002100h	0FFFFh – 0FFC0h 019FFFh – 003100h	0FFFFh – 0FFC0h 01FFFFh – 003100h	0FFFFh – 0FFC0h 01FFFFh – 002100h
RAM (Total)	Size	4KB	8KB	8KB	4KB
	Extended	020FFh – 01100h	030FFh – 01100h	030FFh – 01100h	020FFh – 01100h
	Mirrored	020FFh – 01900h	030FFh – 01900h	030FFh – 01900h	020FFh – 01900h
Information memory	Size	256 Byte	256 Byte	256 Byte	256 Byte
	Flash	010FFh – 01000h	010FFh – 01000h	010FFh – 01000h	010FFh – 01000h
Boot memory	Size	1KB	1KB	1KB	1KB
	ROM	0FFFh – 0C00h	0FFFh – 0C00h	0FFFh – 0C00h	0FFFh – 0C00h
RAM (mirrored at 018FFh – 01100h)	Size	2KB	2KB	2KB	2KB
Peripherals	16-bit	01FFh – 0100h	01FFh – 0100h	01FFh – 0100h	01FFh – 0100h
	8-bit	0FFh – 010h	0FFh – 010h	0FFh – 010h	0FFh – 010h
	8-bit SFR	0Fh – 00h	0Fh – 00h	0Fh – 00h	0Fh – 00h

## bootstrap loader (BSL)

The MSP430 bootstrap loader (BSL) enables users to program the flash memory or RAM using a UART serial interface. Access to the MSP430 memory via the BSL is protected by user-defined password. For complete description of the features of the BSL and its implementation, see the *MSP430 Memory Programming User's Guide*, literature number SLAU265.

BSL FUNCTION	PZ PACKAGE PINS
Data Transmit	87 - P1.0
Data Receive	86 - P1.1

## flash memory

The flash memory can be programmed via the JTAG port, the bootstrap loader, or in-system by the CPU. The CPU can perform single-byte and single-word writes to the flash memory. Features of the flash memory include:

- Flash memory has n segments of main memory and four segments of information memory (A to D) of 64 bytes each. Each segment in main memory is 512 bytes in size.
- Segments 0 to n may be erased in one step, or each segment may be individually erased.
- Segments A to D can be erased individually, or as a group with segments 0 to n. Segments A to D are also called *information memory*.
- Segment A might contain calibration data. After reset segment A is protected against programming or erasing. It can be unlocked but care should be taken not to erase this segment if the calibration data is required.
- Flash content integrity check with marginal read modes.



## peripherals

Peripherals are connected to the CPU through data, address, and control buses and can be handled using all instructions. For complete module descriptions, see the *MSP430x4xx Family User's Guide*, literature number SLAU056.

## oscillator and system clock

The clock system is supported by the FLL+ module that includes support for a 32768-Hz watch crystal oscillator, an internal digitally-controlled oscillator (DCO) and an 8-MHz high-frequency crystal oscillator (XT1) plus a 16-MHz high-frequency crystal oscillator (XT2). The FLL+ clock module is designed to meet the requirements of both low system cost and low power consumption. The FLL+ features a digital frequency locked loop (FLL) hardware that, in conjunction with a digital modulator, stabilizes the DCO frequency to a programmable multiple of the watch crystal frequency. The internal DCO provides a fast turn-on clock source and stabilizes in less than 6  $\mu$ s. The FLL+ module provides the following clock signals:

- Auxiliary clock (ACLK), sourced from a 32768-Hz watch crystal or a high-frequency crystal
- Main clock (MCLK), the system clock used by the CPU
- Sub-Main clock (SMCLK), the sub-system clock used by the peripheral modules
- ACLK/n, the buffered output of ACLK, ACLK/2, ACLK/4, or ACLK/8

## brownout, supply voltage supervisor (SVS)

The brownout circuit is implemented to provide the proper internal reset signal to the device during power on and power off. The SVS circuitry detects if the supply voltage drops below a user selectable level and supports both supply voltage supervision (the device is automatically reset) and supply voltage monitoring (SVM, the device is not automatically reset).

The CPU begins code execution after the brownout circuit releases the device reset. However,  $V_{CC}$  may not have ramped to  $V_{CC(min)}$  at that time. The user must insure the default FLL+ settings are not changed until  $V_{CC}$  reaches  $V_{CC(min)}$ . If desired, the SVS circuit can be used to determine when  $V_{CC}$  reaches  $V_{CC(min)}$ .

## digital I/O

There are nine 8-bit I/O ports implemented—ports P1 through P5 and P7 through P10.

- All individual I/O bits are independently programmable.
- Any combination of input, output, and interrupt conditions is possible.
- Edge-selectable interrupt input capability for all the eight bits of ports P1 and P2.
- Read/write access to port-control registers is supported by all instructions.
- Ports P7/P8 and P9/P10 can be accessed word-wise as ports PA and PB respectively.
- Each I/O has an individually programmable pullup/pulldown resistor.

**Note:** Only four bits of port P10 (P10.0 to P10.3) are available on external pins, but all control and data bits for port P10 are implemented.

# MSP430F471x6, MSP430F471x7 MIXED SIGNAL MICROCONTROLLER

SLAS626A – OCTOBER 2008 – REVISED MAY 2009

## DMA controller

The DMA controller allows movement of data from one memory address to another without CPU intervention. For example, the DMA controller can be used to move data from a USCI module to RAM. Using the DMA controller can increase the throughput of peripheral modules. The DMA controller reduces system power consumption by allowing the CPU to remain in sleep mode without having to awaken to move data to or from a peripheral.

DMA TRIGGER SELECT DMAXTSELX	DESCRIPTION
0000	DMAREQ bit (software trigger)
0001	TACCR2 CCIFG bit
0010	TBCCR2 CCIFG bit
0011	UCA0RXIFG bit
0100	UCA0TXIFG bit
0101	N/A
0110	SD16IFG bit
0111	TACCR0 CCIFG bit
1000	TBCCR0 CCIFG bit
1001	UCA1RXIFG bit
1010	UCA1TXIFG bit
1011	Multiplier ready
1100	UCB0RXIFG bit
1101	UCB0TXIFG bit
1110	DMA0IFG bit triggers DMA channel 1 DMA1IFG bit triggers DMA channel 2 DMA2IFG bit triggers DMA channel 0
1111	External trigger DMAE0

## hardware multiplier

The multiplication operation is supported by a dedicated peripheral module. The module performs operations with 32-bit, 24-bit, 16-bit and 8-bit operands. The module is capable of supporting signed and unsigned multiplication as well as signed and unsigned multiply and accumulate operations.

## watchdog timer (WDT+)

The primary function of the WDT+ module is to perform a controlled system restart after a software problem occurs. If the selected time interval expires, a system reset is generated. If the watchdog function is not needed in an application, the module can be configured as an interval timer and can generate interrupts at selected time intervals.

## Basic Timer1 and Real-Time Clock (RTC)

The Basic Timer1 has two independent 8-bit timers that can be cascaded to form a 16-bit timer/counter. Both timers can be read and written by software. The Basic Timer1 is extended to provide an integrated real-time clock (RTC). An internal calendar compensates for months with less than 31 days and includes leap year correction.





**universal serial communication interfaces (USCIs) (USCI\_A0, USCI\_B0, USCI\_A1, USCI\_B1)**

The USCI module is used for serial data communication. The USCI module supports synchronous communication protocols such as SPI (3-pin or 4-pin) and I2C and asynchronous communication protocols such as UART, enhanced UART with automatic baudrate detection (LIN), and IrDA.

USCI\_A0 and USCI\_A1 provides support for SPI (3-pin or 4-pin), UART, enhanced UART, and IrDA.

USCI\_B0 and USCI\_B1 provides support for SPI (3-pin or 4-pin) and I2C.

**Timer\_A3**

Timer\_A3 is a 16-bit timer/counter with three capture/compare registers. Timer\_A3 can support multiple capture/compares, PWM outputs, and interval timing. Timer\_A3 also has extensive interrupt capabilities. Interrupts may be generated from the counter on overflow conditions and from each of the capture/compare registers.

TIMER_A3 SIGNAL CONNECTIONS					
INPUT PIN NUMBER	DEVICE INPUT SIGNAL	MODULE INPUT NAME	MODULE BLOCK	MODULE OUTPUT SIGNAL	OUTPUT PIN NUMBER
86 - P1.5	TACLK	TACLK	Timer	NA	
	ACLK	ACLK			
	SMCLK	SMCLK			
86 - P1.5	TACLK	INCLK			
91 - P1.0	TA0	CCI0A	CCR0	TA0	91 - P1.0
90 - P1.1	TA0	CCI0B			
	DV <sub>SS</sub>	GND			
	DV <sub>CC</sub>	V <sub>CC</sub>			
89 - P1.2	TA1	CCI1A	CCR1	TA1	89 - P1.2
	CAOUT (internal)	CCI1B			
	DV <sub>SS</sub>	GND			
	DV <sub>CC</sub>	V <sub>CC</sub>			
71 - P3.4	TA2	CCI2A	CCR2	TA2	71 - P3.4
	ACLK (internal)	CCI2B			
	DV <sub>SS</sub>	GND			
	DV <sub>CC</sub>	V <sub>CC</sub>			

# MSP430F471x6, MSP430F471x7 MIXED SIGNAL MICROCONTROLLER

SLAS626A – OCTOBER 2008 – REVISED MAY 2009

## Timer\_B3

Timer\_B3 is a 16-bit timer/counter with three capture/compare registers. Timer\_B3 can support multiple capture/compares, PWM outputs, and interval timing. Timer\_B3 also has extensive interrupt capabilities. Interrupts may be generated from the counter on overflow conditions and from each of the capture/compare registers.

TIMER_B3 SIGNAL CONNECTIONS					
INPUT PIN NUMBER	DEVICE INPUT SIGNAL	MODULE INPUT NAME	MODULE BLOCK	MODULE OUTPUT SIGNAL	OUTPUT PIN NUMBER
87 - P1.4	TBCLK	TBCLK	Timer	NA	
	ACLK	ACLK			
	SMCLK	SMCLK			
87 - P1.4	TBCLK	INCLK			
70 - P3.5	TB0	CCI0A	CCR0	TB0	70 - P3.5
70 - P3.5	TB0	CCI0B			
	DV <sub>SS</sub>	GND			
	DV <sub>CC</sub>	V <sub>CC</sub>			
69 - P3.6	TB1	CCI1A	CCR1	TB1	69 - P3.6
69 - P3.6	TB1	CCI1B			
	DV <sub>SS</sub>	GND			
	DV <sub>CC</sub>	V <sub>CC</sub>			
68 - P3.7	TB2	CCI2A	CCR2	TB2	68 - P3.7
68 - P3.7	TB2	CCI2B			
	DV <sub>SS</sub>	GND			
	DV <sub>CC</sub>	V <sub>CC</sub>			



### **Comparator\_A**

The primary function of the comparator\_A module is to support precision slope analog-to-digital conversions, battery-voltage supervision, and monitoring of external analog signals.

### **SD16\_A**

The SD16\_A module integrates six (MSP430F471x6) or seven (MSP430F471x7) independent 16-bit sigma-delta A/D converters. Each channel is designed with a fully differential analog input pair and programmable gain amplifier input stage. In addition to external analog inputs, an internal  $V_{CC}$  sense and temperature sensor are also available.

### **LCD driver with regulated charge pump**

The LCD\_A driver generates the segment and common signals required to drive an LCD display. The LCD\_A controller has dedicated data memory to hold segment drive information. Common and segment signals are generated as defined by the mode. Static, 2-MUX, 3-MUX, and 4-MUX LCDs are supported by this peripheral. The module can provide a LCD voltage independent of the supply voltage via an integrated charge pump. Furthermore it is possible to control the level of the LCD voltage and thus contrast in software.

### **embedded emulation module (EEM)**

All MSP430F471x6 and MSP430F471x7 devices have an EEM that supports real-time in-system debugging. The implemented L version of the EEM has the following features:

- Eight hardware triggers on memory address or data bus
- Two hardware triggers on write accesses to CPU register
- Eight combinational triggers to combine any of the 10 above hardware triggers
- Trigger sequencer
- CPU break reaction on combinational triggers for breakpoints
- State storage to trace internal buses
- Clock control on module level

# MSP430F471x6, MSP430F471x7 MIXED SIGNAL MICROCONTROLLER

SLAS626A – OCTOBER 2008 – REVISED MAY 2009

## peripheral file map

PERIPHERALS WITH WORD ACCESS			
<b>Watchdog</b>	Watchdog timer control	WDTCTL	0120h
<b>Flash_A</b>	Flash control 4	FCTL4	01BEh
	Flash control 3	FCTL3	012Ch
	Flash control 2	FCTL2	012Ah
	Flash control 1	FCTL1	0128h
<b>Timer_B3</b>	Capture/compare register 2	TBCCR2	0196h
	Capture/compare register 1	TBCCR1	0194h
	Capture/compare register 0	TBCCR0	0192h
	Timer_B register	TBR	0190h
	Capture/compare control 2	TBCCTL2	0186h
	Capture/compare control 1	TBCCTL1	0184h
	Capture/compare control 0	TBCCTL0	0182h
	Timer_B control	TBCTL	0180h
	Timer_B interrupt vector	TBIV	011Eh
<b>Timer_A3</b>	Capture/compare register 2	TACCR2	0176h
	Capture/compare register 1	TACCR1	0174h
	Capture/compare register 0	TACCR0	0172h
	Timer_A register	TAR	0170h
	Capture/compare control 2	TACCTL2	0166h
	Capture/compare control 1	TACCTL1	0164h
	Capture/compare control 0	TACCTL0	0162h
	Timer_A control	TACTL	0160h
	Timer_A interrupt vector	TAIV	012Eh
<b>32-bit Hardware Multiplier</b>	MPY32 control 0	MPY32CTL0	015Ch
	64-bit result 3 – most significant word	RES3	015Ah
	64-bit result 2	RES2	0158h
	64-bit result 1	RES1	0156h
	64-bit result 0 – least significant word	RES0	0154h
	Second 32-bit operand, high word	OP2H	0152h
	Second 32-bit operand, low word	OP2L	0150h
	Multiply signed + accumulate/ 32-bit operand1, high word	MACS32H	014Eh
	Multiply signed + accumulate/ 32-bit operand1, low word	MACS32L	014Ch
	Multiply + accumulate/ 32-bit operand1, high word	MAC32H	014Ah
	Multiply + accumulate/ 32-bit operand1, low word	MAC32L	0148h
	Multiply signed/32-bit operand1, high word	MPYS32H	0146h
	Multiply signed/32-bit operand1, low word	MPYS32L	0144h
	Multiply unsigned/32-bit operand1, high word	MPY32H	0142h
	Multiply unsigned/32-bit operand1, low word	MPY32L	0140h



**peripheral file map (continued)**

<b>PERIPHERALS WITH WORD ACCESS (CONTINUED)</b>			
<b>32-bit Hardware Multiplier</b>	Sum extend	SUMEXT	013Eh
	Result high word	RESHI	013Ch
	Result low word	RESLO	013Ah
	Second operand	OP2	0138h
	Multiply signed + accumulate/operand1	MACS	0136h
	Multiply + accumulate/operand1	MAC	0134h
	Multiply signed/operand1	MPYS	0132h
	Multiply unsigned/operand1	MPY	0130h
<b>USCI_B0</b> (see also: Peripherals with Byte Access)	USCI_B0 I2C own address	UCB0I2COA	016Ch
	USCI_B0 I2C slave address	UCB0I2CSA	016Eh
<b>USCI_B1</b> (see also: Peripherals with Byte Access)	USCI_B1 I2C own address	UCB1I2COA	017Ch
	USCI_B1 I2C slave address	UCB1I2CSA	017Eh
<b>SD16_A</b> (see also: Peripherals with Byte Access)	General Control	SD16CTL	0100h
	Channel 0 Control	SD16CCTL0	0102h
	Channel 1 Control	SD16CCTL1	0104h
	Channel 2 Control	SD16CCTL2	0106h
	Channel 3 Control	SD16CCTL3	0108h
	Channel 4 Control	SD16CCTL4	010Ah
	Channel 5 Control	SD16CCTL5	010Ch
	Channel 6 Control	SD16CCTL6	010Eh
	Channel 0 conversion memory	SD16MEM0	0110h
	Channel 1 conversion memory	SD16MEM1	0112h
	Channel 2 conversion memory	SD16MEM2	0114h
	Channel 3 conversion memory	SD16MEM3	0116h
	Channel 4 conversion memory	SD16MEM4	0118h
	Channel 5 conversion memory	SD16MEM5	011Ah
	Channel 6 conversion memory	SD16MEM6	011Ch
	SD16 Interrupt vector word register	SD16IV	01AEh
<b>Port PA</b>	Port PA resistor enable	PAREN	014h
	Port PA selection	PASEL	03Eh
	Port PA direction	PADIR	03Ch
	Port PA output	PAOUT	03Ah
	Port PA input	PAIN	038h
<b>Port PB</b>	Port PB resistor enable	PBREN	016h
	Port PB selection	PBSEL	00Eh
	Port PB direction	PBDIR	00Ch
	Port PB output	PBOUT	00Ah
	Port PB input	PBIN	008h

# MSP430F471x6, MSP430F471x7 MIXED SIGNAL MICROCONTROLLER

SLAS626A – OCTOBER 2008 – REVISED MAY 2009

## peripheral file map (continued)

PERIPHERALS WITH WORD ACCESS (CONTINUED)			
<b>DMA</b>	DMA module control 0	DMACTL0	0122h
	DMA module control 1	DMACTL1	0124h
	DMA interrupt vector	DMAIV	0126h
<b>DMA Channel 0</b>	DMA channel 0 control	DMA0CTL	01D0h
	DMA channel 0 source address	DMA0SA	01D2h
	DMA channel 0 destination address	DMA0DA	01D6h
	DMA channel 0 transfer size	DMA0SZ	01DAh
<b>DMA Channel 1</b>	DMA channel 1 control	DMA1CTL	01DCh
	DMA channel 1 source address	DMA1SA	01DEh
	DMA channel 1 destination address	DMA1DA	01E2h
	DMA channel 1 transfer size	DMA1SZ	01E6h
<b>DMA Channel 2</b>	DMA channel 2 control	DMA2CTL	01E8h
	DMA channel 2 source address	DMA2SA	01EAh
	DMA channel 2 destination address	DMA2DA	01EEh
	DMA channel 2 transfer size	DMA2SZ	01F2h



**peripheral file map (continued)**

<b>PERIPHERALS WITH BYTE ACCESS</b>				
<b>SD16_A</b> (see also: Peripherals with Word Access)	Channel 0 Input Control	SD16INCTL0	0B0h	
	Channel 1 Input Control	SD16INCTL1	0B1h	
	Channel 2 Input Control	SD16INCTL2	0B2h	
	Channel 3 Input Control	SD16INCTL3	0B3h	
	Channel 4 Input Control	SD16INCTL4	0B4h	
	Channel 5 Input Control	SD16INCTL5	0B5h	
	Channel 6 Input Control	SD16INCTL6	0B6h	
	Reserved		0B7h	
	Channel 0 preload	SD16PRE0	0B8h	
	Channel 1 preload	SD16PRE1	0B9h	
	Channel 2 preload	SD16PRE2	0BAh	
	Channel 3 preload	SD16PRE3	0BBh	
	Channel 4 preload	SD16PRE4	0BCh	
	Channel 5 preload	SD16PRE5	0BDh	
	Channel 6 preload	SD16PRE6	0BEh	
	Reserved	SD16CONF1	0BFh	
	<b>LCD_A</b>	LCD Voltage Control 1	LCDAVCTL1	0AFh
		LCD Voltage Control 0	LCDAVCTL0	0AEh
		LCD Voltage Port Control 1	LCDAPCTL1	0ADh
		LCD Voltage Port Control 0	LCDAPCTL0	0ACh
LCD memory 20		LCDM20	0A4h	
:		:	:	
LCD memory 16		LCDM16	0A0h	
LCD memory 15		LCDM15	09Fh	
:		:	:	
LCD memory 1		LCDM1	091h	
LCD control and mode		LCDACTL	090h	

# MSP430F471x6, MSP430F471x7 MIXED SIGNAL MICROCONTROLLER

SLAS626A – OCTOBER 2008 – REVISED MAY 2009

## peripheral file map (continued)

PERIPHERALS WITH BYTE ACCESS (CONTINUED)			
<b>USCI_A0</b>	USCI_A0 transmit buffer	UCA0TXBUF	067h
	USCI_A0 receive buffer	UCA0RXBUF	066h
	USCI_A0 status	UCA0STAT	065h
	USCI_A0 modulation control	UCA0MCTL	064h
	USCI_A0 baud rate control 1	UCA0BR1	063h
	USCI_A0 baud rate control 0	UCA0BR0	062h
	USCI_A0 control 1	UCA0CTL1	061h
	USCI_A0 control 0	UCA0CTL0	060h
	USCI_A0 IrDA receive control	UCA0IRRCTL	05Fh
	USCI_A0 IrDA transmit control	UCA0IRTCTL	05Eh
	USCI_A0 auto baud rate control	UCA0ABCTL	05Dh
	<b>USCI_B0</b>	USCI_B0 transmit buffer	UCB0TXBUF
USCI_B0 receive buffer		UCB0RXBUF	06Eh
USCI_B0 status		UCB0STAT	06Dh
USCI_B1 I2C interrupt enable		UCB0I2CIE	06Ch
USCI_B0 bit rate control 1		UCB0BR1	06Bh
USCI_B0 bit rate control 0		UCB0BR0	06Ah
USCI_B0 control 1		UCB0CTL1	069h
USCI_B0 control 0		UCB0CTL0	068h
<b>USCI_A1</b>	USCI_A1 transmit buffer	UCA1TXBUF	0D7h
	USCI_A1 receive buffer	UCA1RXBUF	0D6h
	USCI_A1 status	UCA1STAT	0D5h
	USCI_A1 modulation control	UCA1MCTL	0D4h
	USCI_A1 baud rate control 1	UCA1BR1	0D3h
	USCI_A1 baud rate control 0	UCA1BR0	0D2h
	USCI_A1 control 1	UCA1CTL1	0D1h
	USCI_A1 control 0	UCA1CTL0	0D0h
	USCI_A1 IrDA receive control	UCA1IRRCTL	0CFh
	USCI_A1 IrDA transmit control	UCA1IRTCTL	0CEh
	USCI_A1 auto baud rate control	UCA1ABCTL	0CDh
	USCI_A1 interrupt flag	UC1IFG	007h
	USCI_A1 interrupt enable	UC1IE	006h
<b>USCI_B1</b>	USCI_B1 transmit buffer	UCB1TXBUF	0DFh
	USCI_B1 receive buffer	UCB1RXBUF	0DEh
	USCI_B1 status	UCB1STAT	0DDh
	USCI_B1 I2C interrupt enable	UCB1I2CIE	0DCh
	USCI_B1 bit rate control 1	UCB1BR1	0DBh
	USCI_B1 bit rate control 0	UCB1BR0	0DAh
	USCI_B1 control 1	UCB1CTL1	0D9h
	USCI_B1 control 0	UCB1CTL0	0D8h
	USCI_A1 interrupt flag	UC1IFG	007h
	USCI_A1 interrupt enable	UC1IE	006h
	<b>Comparator_A</b>	Comparator_A port disable	CAPD
Comparator_A control2		CACTL2	05Ah
Comparator_A control1		CACTL1	059h
<b>BrownOUT, SVS</b>	SVS control register (Reset by brownout signal)	SVSCTL	056h



**peripheral file map (continued)**

<b>PERIPHERALS WITH BYTE ACCESS (CONTINUED)</b>				
<b>FLL+ Clock</b>	FLL+ Control2	FLL_CTL2	055h	
	FLL+ Control1	FLL_CTL1	054h	
	FLL+ Control0	FLL_CTL0	053h	
	System clock frequency control	SCFQCTL	052h	
	System clock frequency integrator	SCFI1	051h	
	System clock frequency integrator	SCFI0	050h	
<b>RTC (Basic Timer 1)</b>	Real Time Clock Year High Byte	RTCYEARH	04Fh	
	Real Time Clock Year Low Byte	RTCYEARL	04Eh	
	Real Time Clock Month	RTCMON	04Dh	
	Real Time Clock Day of Month	RTCDAY	04Ch	
	Basic Timer1 Counter 2	BTCNT2	047h	
	Basic Timer1 Counter 1	BTCNT1	046h	
	Real Time Counter 4 (Real Time Clock Day of Week)	RTCNT4 (RTCDOW)	045h	
	Real Time Counter 3 (Real Time Clock Hour)	RTCNT3 (RTCHOUR)	044h	
	Real Time Counter 2 (Real Time Clock Minute)	RTCNT2 (RTCMIN)	043h	
	Real Time Counter 1 (Real Time Clock Second)	RTCNT1 (RTCSEC)	042h	
	Real Time Clock Control	RTCCTL	041h	
	Basic Timer1 Control	BTCTL	040h	
	<b>Port P10</b>	Port P10 resistor enable	P10REN	017h
		Port P10 selection	P10SEL	00Fh
Port P10 direction		P10DIR	00Dh	
Port P10 output		P10OUT	00Bh	
Port P10 input		P10IN	009h	
<b>Port P9</b>	Port P9 resistor enable	P9REN	016h	
	Port P9 selection	P9SEL	00Eh	
	Port P9 direction	P9DIR	00Ch	
	Port P9 output	P9OUT	00Ah	
	Port P9 input	P9IN	008h	
<b>Port P8</b>	Port P8 resistor enable	P8REN	015h	
	Port P8 selection	P8SEL	03Fh	
	Port P8 direction	P8DIR	03Dh	
	Port P8 output	P8OUT	03Bh	
	Port P8 input	P8IN	039h	
<b>Port P7</b>	Port P7 resistor enable	P7REN	014h	
	Port P7 selection	P7SEL	03Eh	
	Port P7 direction	P7DIR	03Ch	
	Port P7 output	P7OUT	03Ah	
	Port P7 input	P7IN	038h	

# MSP430F471x6, MSP430F471x7 MIXED SIGNAL MICROCONTROLLER

SLAS626A – OCTOBER 2008 – REVISED MAY 2009

## peripheral file map (continued)

PERIPHERALS WITH BYTE ACCESS (CONTINUED)			
<b>Port P5</b>	Port P5 resistor enable	P5REN	012h
	Port P5 selection	P5SEL	033h
	Port P5 direction	P5DIR	032h
	Port P5 output	P5OUT	031h
	Port P5 input	P5IN	030h
<b>Port P4</b>	Port P4 resistor enable	P4REN	011h
	Port P4 selection	P4SEL	01Fh
	Port P4 direction	P4DIR	01Eh
	Port P4 output	P4OUT	01Dh
	Port P4 input	P4IN	01Ch
<b>Port P3</b>	Port P3 resistor enable	P3REN	010h
	Port P3 selection	P3SEL	01Bh
	Port P3 direction	P3DIR	01Ah
	Port P3 output	P3OUT	019h
	Port P3 input	P3IN	018h
<b>Port P2</b>	Port P2 resistor enable	P2REN	02Fh
	Port P2 selection	P2SEL	02Eh
	Port P2 interrupt enable	P2IE	02Dh
	Port P2 interrupt-edge select	P2IES	02Ch
	Port P2 interrupt flag	P2IFG	02Bh
	Port P2 direction	P2DIR	02Ah
	Port P2 output	P2OUT	029h
	Port P2 input	P2IN	028h
<b>Port P1</b>	Port P1 resistor enable	P1REN	027h
	Port P1 selection	P1SEL	026h
	Port P1 interrupt enable	P1IE	025h
	Port P1 interrupt-edge select	P1IES	024h
	Port P1 interrupt flag	P1IFG	023h
	Port P1 direction	P1DIR	022h
	Port P1 output	P1OUT	021h
	Port P1 input	P1IN	020h
<b>Special Functions</b>	SFR interrupt flag2	IFG2	003h
	SFR interrupt flag1	IFG1	002h
	SFR interrupt enable2	IE2	001h
	SFR interrupt enable1	IE1	000h



**absolute maximum ratings (see Note 1)**

Voltage applied at $V_{CC}$ to $V_{SS}$ .....	–0.3 V to 4.1 V
Voltage applied to any pin (see Note 2) .....	–0.3 V to $V_{CC} + 0.3$ V
Diode current at any device terminal . . . . .	$\pm 2$ mA
Storage temperature, $T_{stg}$ : Unprogrammed device (see Note 3) .....	–55°C to 150°C
Programmed device (see Note 3) .....	–40°C to 85°C

- NOTES: 1. Stresses beyond those listed under “absolute maximum ratings” may cause permanent damage to the device. These are stress ratings only, and functional operation of the device at these or any other conditions beyond those indicated under “recommended operating conditions” is not implied. Exposure to absolute-maximum-rated conditions for extended periods may affect device reliability.
2. All voltages referenced to  $V_{SS}$ . The JTAG fuse-blow voltage,  $V_{FB}$ , is allowed to exceed the absolute maximum rating. The voltage is applied to the TDI/TCLK pin when blowing the JTAG fuse.
3. Higher temperature may be applied during board soldering process according to the current JEDEC J–STD–020 specification with peak reflow temperatures not higher than classified on the device label on the shipping boxes or reels.

# MSP430F471x6, MSP430F471x7 MIXED SIGNAL MICROCONTROLLER

SLAS626A – OCTOBER 2008 – REVISED MAY 2009

## recommended operating conditions

	MIN	NOM	MAX	UNIT
Supply voltage during program execution, $V_{CC}$ ( $AV_{CC} = DV_{CC} = V_{CC}$ ) (see Note 1)	1.8		3.6	V
Supply voltage during program execution, SVS enabled, PORON = 1, $V_{CC}$ ( $AV_{CC} = DV_{CC} = V_{CC}$ ) (see Notes 1, 2)	2.0		3.6	V
Supply voltage during program/erase flash memory, $V_{CC}$ ( $AV_{CC} = DV_{CC} = V_{CC}$ ) (see Note 1)	2.2		3.6	V
Supply voltage, $V_{SS}$		0		V
Operating free-air temperature range, $T_A$	-40		85	°C
Processor frequency $f_{SYSTEM}$ (Maximum MCLK frequency) (see Notes 3, 4 and Figure 1)	$V_{CC} = 1.8$ V, Duty cycle = 50% $\pm$ 10%	dc	4.15	MHz
	$V_{CC} = 2.2$ V, Duty cycle = 50% $\pm$ 10%	dc	7.5	MHz
	$V_{CC} = 2.7$ V, Duty cycle = 50% $\pm$ 10%	dc	12	MHz
	$V_{CC} \geq 3.3$ V, Duty cycle = 50% $\pm$ 10%	dc	16	

- NOTES: 1. It is recommended to power  $AV_{CC}$  and  $DV_{CC}$  from the same source. A maximum difference of 0.3 V between  $AV_{CC}$  and  $DV_{CC}$  can be tolerated during power up and operation.
2. The minimum operating supply voltage is defined according to the trip point where POR is going active by decreasing supply voltage. POR is going inactive when the supply voltage is raised above minimum supply voltage plus the hysteresis of the SVS circuitry.
3. The MSP430 CPU is clocked directly with MCLK. Both the high and low phase of MCLK must not exceed the pulse width of the specified maximum frequency.
4. Modules might have a different maximum input clock specification. Refer to the specification of the respective module in this data sheet.

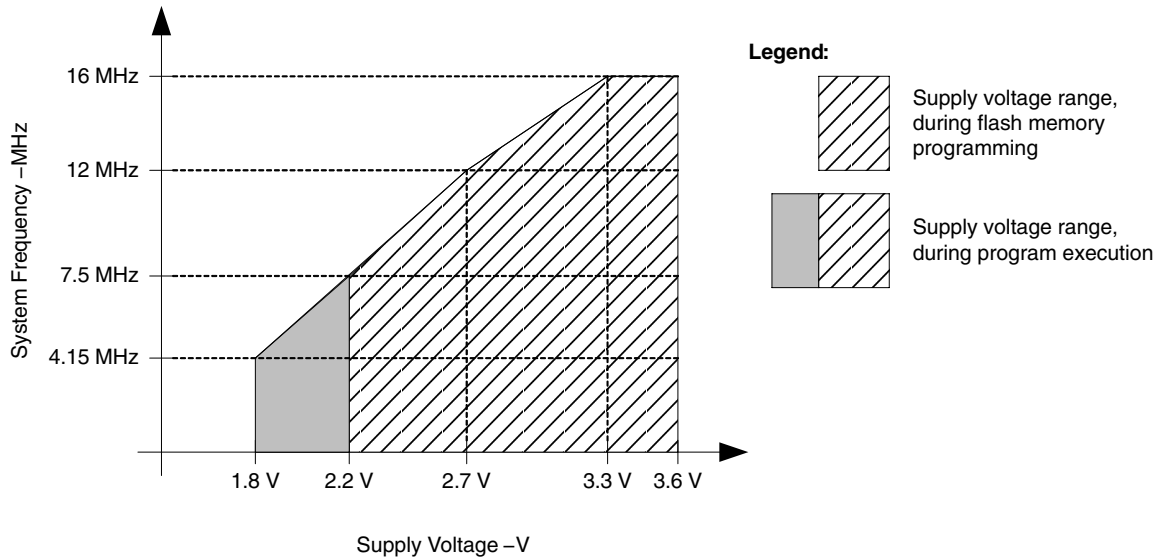

NOTE: Minimum processor frequency is defined by system clock. Flash program or erase operations require a minimum  $V_{CC}$  of 2.2 V.

**Figure 1. Operating Area**

**electrical characteristics over recommended operating free-air temperature (unless otherwise noted)**

**supply current into AV<sub>CC</sub> + DV<sub>CC</sub> excluding external current**

PARAMETER		TEST CONDITIONS	V <sub>CC</sub>	MIN	TYP	MAX	UNIT
I <sub>(AM)</sub>	Active mode, (see Note 1) f <sub>(MCLK)</sub> = f <sub>(SMCLK)</sub> = 1 MHz, f <sub>(ACLK)</sub> = 32768 Hz XTS = 0, SELM = (0,1) (Program executes from flash)	T <sub>A</sub> = -40°C to 85°C	2.2 V		350	400	μA
			3 V		500	560	
I <sub>(LPM0)</sub>	Low-power mode, (LPM0) (see Notes 1, 4)	T <sub>A</sub> = -40°C to 85°C	2.2 V		45	70	μA
			3 V		75	110	
I <sub>(LPM2)</sub>	Low-power mode, (LPM2), f <sub>(MCLK)</sub> = f <sub>(SMCLK)</sub> = 0 MHz, f <sub>(ACLK)</sub> = 32768 Hz, SCG0 = 0 (see Notes 2, 4)	T <sub>A</sub> = -40°C to 85°C	2.2 V		11	14	μA
			3 V		17	22	
I <sub>(LPM3)</sub>	Low-power mode, (LPM3) f <sub>(MCLK)</sub> = f <sub>(SMCLK)</sub> = 0 MHz, f <sub>(ACLK)</sub> = 32768 Hz, SCG0 = 1 Basic Timer1 and RTC enabled, ACLK selected LCD_A enabled, LCDCPEN = 0: (static mode, f <sub>LCD</sub> = f <sub>(ACLK)</sub> /32) (see Notes 2, 3, and 4)	T <sub>A</sub> = -40°C	2.2 V		0.7	2.0	μA
		T <sub>A</sub> = 25°C			0.8	2.0	
		T <sub>A</sub> = 60°C			2.0	3.5	
		T <sub>A</sub> = 85°C			5.0	9.5	
		T <sub>A</sub> = -40°C	3 V		1.1	3.0	μA
		T <sub>A</sub> = 25°C			1.2	3.0	
		T <sub>A</sub> = 60°C			2.5	4.0	
		T <sub>A</sub> = 85°C			6.0	10.0	
I <sub>(LPM3)</sub>	Low-power mode, (LPM3) f <sub>(MCLK)</sub> = f <sub>(SMCLK)</sub> = 0 MHz, f <sub>(ACLK)</sub> = 32768 Hz, SCG0 = 1 Basic Timer1 and RTC enabled, ACLK selected LCD_A enabled, LCDCPEN = 0: (4-mux mode, f <sub>LCD</sub> = f <sub>(ACLK)</sub> /32) (see Notes 2, 3, and 4)	T <sub>A</sub> = -40°C	2.2 V		3.5	5.5	μA
		T <sub>A</sub> = 25°C			3.5	5.5	
		T <sub>A</sub> = 60°C			5.5	7.0	
		T <sub>A</sub> = 85°C			11.0	17.0	
		T <sub>A</sub> = -40°C	3 V		4.0	6.5	μA
		T <sub>A</sub> = 25°C			4.0	6.5	
		T <sub>A</sub> = 60°C			6.0	8.0	
		T <sub>A</sub> = 85°C			13.0	20.0	
I <sub>(LPM4)</sub>	Low-power mode, (LPM4) f <sub>(MCLK)</sub> = 0 MHz, f <sub>(SMCLK)</sub> = 0 MHz, f <sub>(ACLK)</sub> = 0 Hz, SCG0 = 1 (see Notes 2 and 4)	T <sub>A</sub> = -40°C	2.2 V		0.1	1.0	μA
		T <sub>A</sub> = 25°C			0.2	1.0	
		T <sub>A</sub> = 60°C			1.0	2.5	
		T <sub>A</sub> = 85°C			4.5	8.5	
		T <sub>A</sub> = -40°C	3 V		0.1	2.0	μA
		T <sub>A</sub> = 25°C			0.2	2.0	
		T <sub>A</sub> = 60°C			1.5	3.0	
		T <sub>A</sub> = 85°C			5.0	9.0	

- NOTES: 1. Timer\_A is clocked by f<sub>(DCOCLK)</sub> = f<sub>(DCO)</sub> = 1 MHz. All inputs are tied to 0 V or to V<sub>CC</sub>. Outputs do not source or sink any current.  
 2. All inputs are tied to 0 V or to V<sub>CC</sub>. Outputs do not source or sink any current.  
 3. The LPM3 currents are characterized with a Micro Crystal CC4V-T1A (9 pF) crystal and OSCCAPx = 01h.  
 4. Current for brownout included.

# MSP430F471x6, MSP430F471x7 MIXED SIGNAL MICROCONTROLLER

SLAS626A – OCTOBER 2008 – REVISED MAY 2009

## typical characteristics – active mode supply current (into $V_{CC}$ )

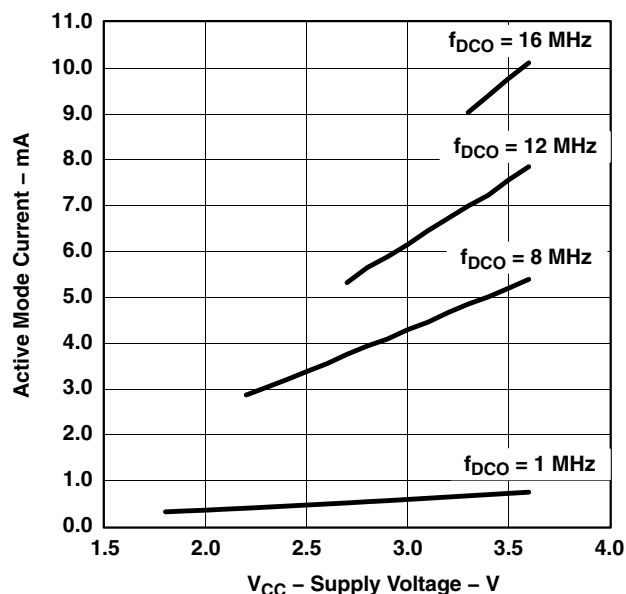

Figure 2. Active Mode Current vs  $V_{CC}$ ,  $T_A = 25^\circ\text{C}$

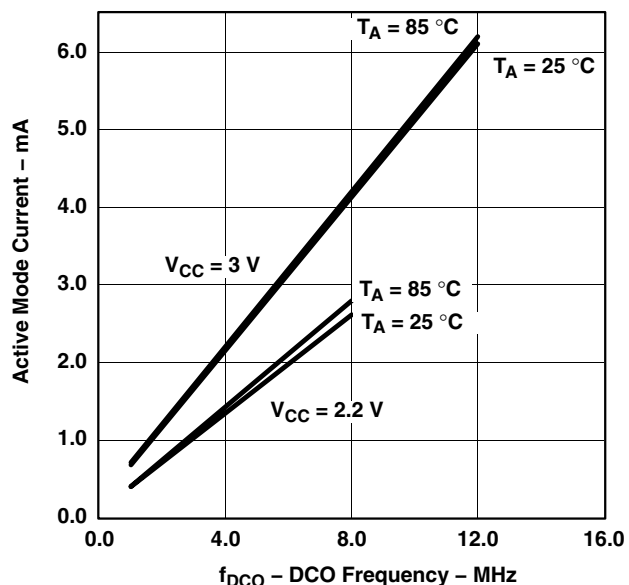

Figure 3. Active Mode Current vs DCO Frequency

electrical characteristics over recommended ranges of supply voltage and operating free-air temperature (unless otherwise noted) (continued)

**Schmitt-trigger inputs – Ports P1 to P5, P7 to P10, RST/NMI, JTAG (TCK, TMS, TDI/TCLK, TDO/TDI)**

PARAMETER		TEST CONDITIONS	V <sub>CC</sub>	MIN	TYP	MAX	UNIT
V <sub>IT+</sub>	Positive-going input threshold voltage			0.45		0.75	V <sub>CC</sub>
			2.2 V	1.00		1.65	V
			3 V	1.35		2.25	V
V <sub>IT-</sub>	Negative-going input threshold voltage			0.25		0.55	V <sub>CC</sub>
			2.2 V	0.55		1.20	V
			3 V	0.75		1.65	V
V <sub>hys</sub>	Input voltage hysteresis (V <sub>IT+</sub> – V <sub>IT-</sub> )		2.2 V	0.2		1.0	V
			3 V	0.3		1.0	V
R <sub>Pull</sub>	Pullup/pulldown resistor (not RST/NMI and JTAG pins)	For pullup: V <sub>IN</sub> = V <sub>SS</sub> , For pulldown: V <sub>IN</sub> = V <sub>CC</sub>		20	35	50	kΩ
C <sub>I</sub>	Input capacitance	V <sub>IN</sub> = V <sub>SS</sub> or V <sub>CC</sub>			5		pF

**inputs – Ports P1, P2**

PARAMETER		TEST CONDITIONS	V <sub>CC</sub>	MIN	MAX	UNIT
t <sub>(int)</sub>	External interrupt timing	Port P1, P2: P1.x to P2.x, external trigger puls width to set interrupt flag (see Note 1)	2.2 V/3 V	20		ns

NOTES: 1. An external signal sets the interrupt flag every time the minimum interrupt puls width t<sub>(int)</sub> is met. It may be set even with trigger signals shorter than t<sub>(int)</sub>.

**leakage current – Ports P1 to P5, P7 to P10**

PARAMETER		TEST CONDITIONS	V <sub>CC</sub>	MIN	MAX	UNIT
I <sub>lkg(Px.x)</sub>	High-impedance leakage current	See Notes 1 and 2	2.2 V/3 V		±50	nA

NOTES: 1. The leakage current is measured with V<sub>SS</sub> or V<sub>CC</sub> applied to the corresponding pin(s), unless otherwise noted.  
2. The leakage of the digital port pins is measured individually. The port pin is selected for input and the pullup/pulldown resistor is disabled.

# MSP430F471x6, MSP430F471x7 MIXED SIGNAL MICROCONTROLLER

SLAS626A – OCTOBER 2008 – REVISED MAY 2009

electrical characteristics over recommended ranges of supply voltage and operating free-air temperature (unless otherwise noted) (continued)

## outputs – Ports P1 to P5, P7 to P10

PARAMETER		TEST CONDITIONS	V <sub>CC</sub>	MIN	MAX	UNIT
V <sub>OH</sub>	High-level output voltage	I <sub>(OHmax)</sub> = -1.5 mA (see Note 1)	2.2 V	V <sub>CC</sub> -0.25	V <sub>CC</sub>	V
		I <sub>(OHmax)</sub> = -6 mA (see Note 2)	2.2 V	V <sub>CC</sub> -0.6	V <sub>CC</sub>	
		I <sub>(OHmax)</sub> = -1.5 mA (see Note 1)	3 V	V <sub>CC</sub> -0.25	V <sub>CC</sub>	
		I <sub>(OHmax)</sub> = -6 mA (see Note 2)	3 V	V <sub>CC</sub> -0.6	V <sub>CC</sub>	
V <sub>OL</sub>	Low-level output voltage	I <sub>(OLmax)</sub> = 1.5 mA (see Note 1)	2.2 V	V <sub>SS</sub>	V <sub>SS</sub> +0.25	V
		I <sub>(OLmax)</sub> = 6 mA (see Note 2)	2.2 V	V <sub>SS</sub>	V <sub>SS</sub> +0.6	
		I <sub>(OLmax)</sub> = 1.5 mA (see Note 1)	3 V	V <sub>SS</sub>	V <sub>SS</sub> +0.25	
		I <sub>(OLmax)</sub> = 6 mA (see Note 2)	3 V	V <sub>SS</sub>	V <sub>SS</sub> +0.6	

- NOTES: 1. The maximum total current, I<sub>OHmax</sub> and I<sub>OLmax</sub>, for all outputs combined, should not exceed ±12 mA to hold the maximum voltage drop specified.  
 2. The maximum total current, I<sub>OHmax</sub> and I<sub>OLmax</sub>, for all outputs combined, should not exceed ±48 mA to hold the maximum voltage drop specified.

## output frequency – Ports P1 to P5, P7 to P10

PARAMETER		TEST CONDITIONS	V <sub>CC</sub>	MIN	MAX	UNIT
f <sub>Px.y</sub>	Port output frequency (with load)	P1.4/TBCLK/SMCLK, C <sub>L</sub> = 20 pF, R <sub>L</sub> = 1 kΩ against V <sub>CC</sub> /2 (see Notes 1 and 2)	2.2 V		10	MHz
			3 V		12	MHz
f <sub>Port_CLK</sub>	Clock output frequency	P1.1/TA0/MCLK, P1.5/TACLK/ACLK, P1.4/TBCLK/SMCLK, C <sub>L</sub> = 20 pF (see Note 2)	2.2 V		12	MHz
			3 V		16	MHz

- NOTES: 1. Alternatively a resistive divider with 2 times 2 kΩ between V<sub>CC</sub> and V<sub>SS</sub> is used as load. The output is connected to the center tap of the divider.  
 2. The output voltage reaches at least 10% and 90% V<sub>CC</sub> at the specified toggle frequency.





electrical characteristics over recommended ranges of supply voltage and operating free-air temperature (unless otherwise noted) (continued)

typical characteristics – outputs

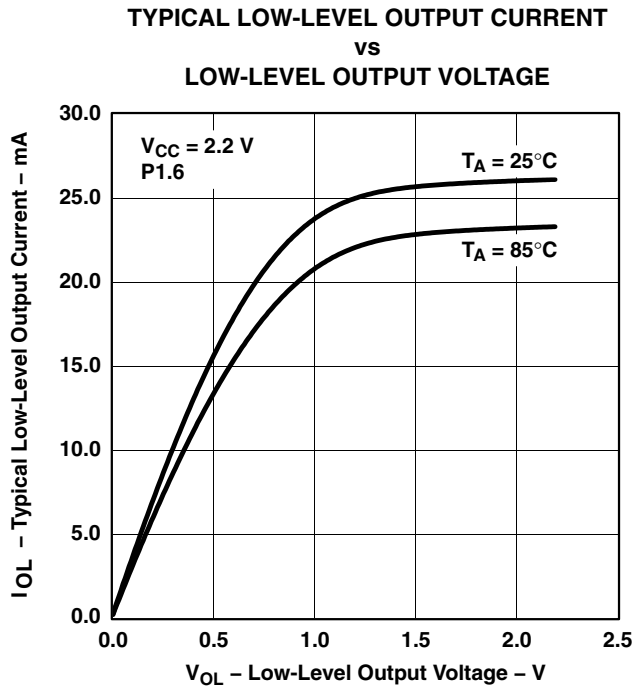

Figure 4

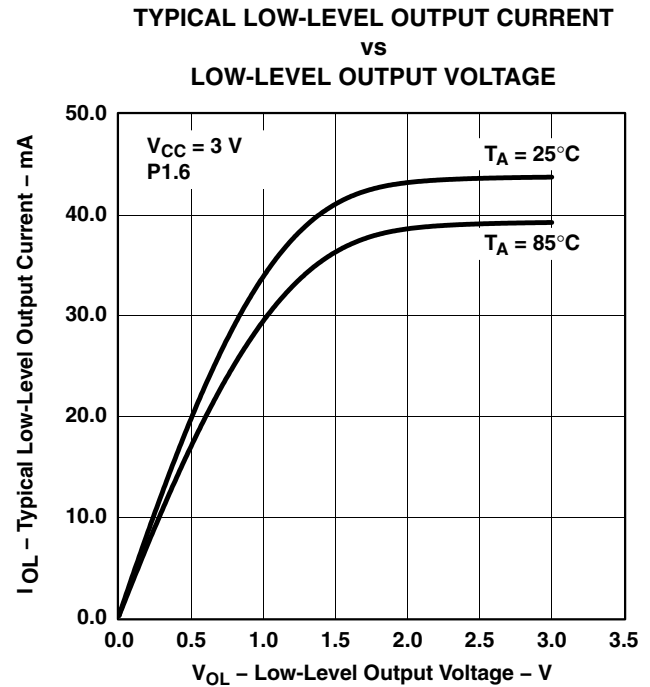

Figure 5

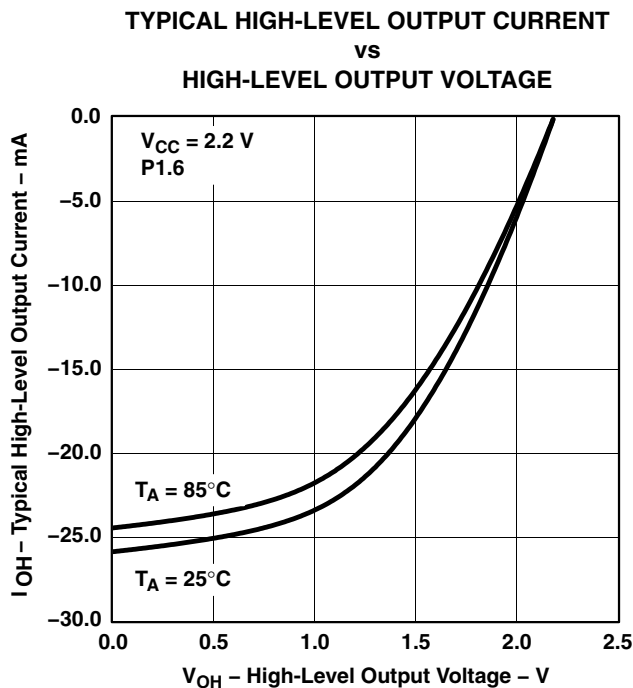

Figure 6

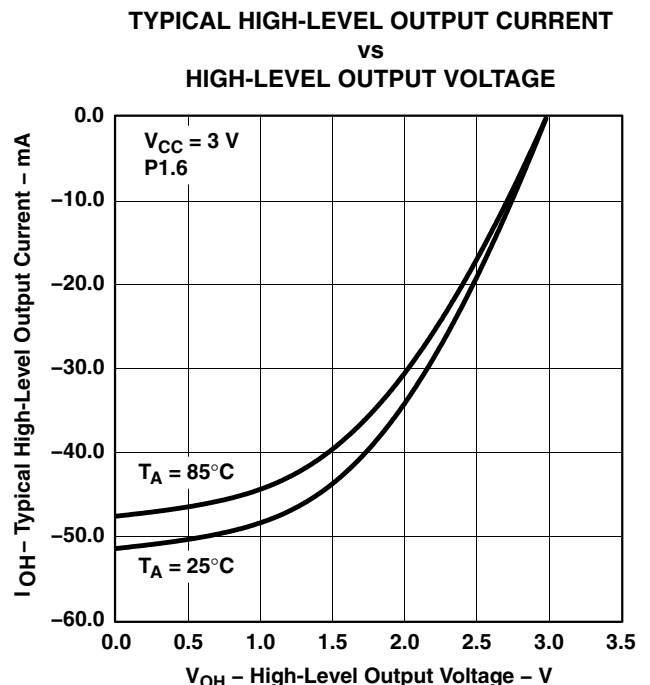

Figure 7

NOTE: One output loaded at a time.

# MSP430F471x6, MSP430F471x7 MIXED SIGNAL MICROCONTROLLER

SLAS626A – OCTOBER 2008 – REVISED MAY 2009

electrical characteristics over recommended ranges of supply voltage and operating free-air temperature (unless otherwise noted) (continued)

## POR/brownout reset (BOR) (see Notes 1 and 2)

PARAMETER	TEST CONDITIONS	V <sub>CC</sub>	MIN	TYP	MAX	UNIT
V <sub>CC(start)</sub>	(See Figure 8)	dV <sub>CC</sub> /dt ≤ 3 V/s		0.7 × V <sub>(B_IT-)</sub>		V
V <sub>(B_IT-)</sub>	(See Figure 8 through Figure 10)	dV <sub>CC</sub> /dt ≤ 3 V/s		1.71		V
V <sub>hys(B_IT-)</sub>	(See Figure 8)	dV <sub>CC</sub> /dt ≤ 3 V/s	70	130	180	mV
t <sub>d(BOR)</sub>	(See Figure 8)			2000		μs
t <sub>(reset)</sub>	Pulse length needed at RST/NMI pin to accepted reset internally	2.2 V/3 V	2			μs

- NOTES: 1. The current consumption of the brownout module is already included in the I<sub>CC</sub> current consumption data. The voltage level V<sub>(B\_IT-)</sub> + V<sub>hys(B\_IT-)</sub> is ≤ 1.8 V.
2. During power up, the CPU begins code execution following a period of t<sub>d(BOR)</sub> after V<sub>CC</sub> = V<sub>(B\_IT-)</sub> + V<sub>hys(B\_IT-)</sub>. The default FLL+ settings must not be changed until V<sub>CC</sub> ≥ V<sub>CC(min)</sub>, where V<sub>CC(min)</sub> is the minimum supply voltage for the desired operating frequency. See the MSP430x4xx Family User's Guide (SLAU056) for more information on the brownout/SVS circuit.

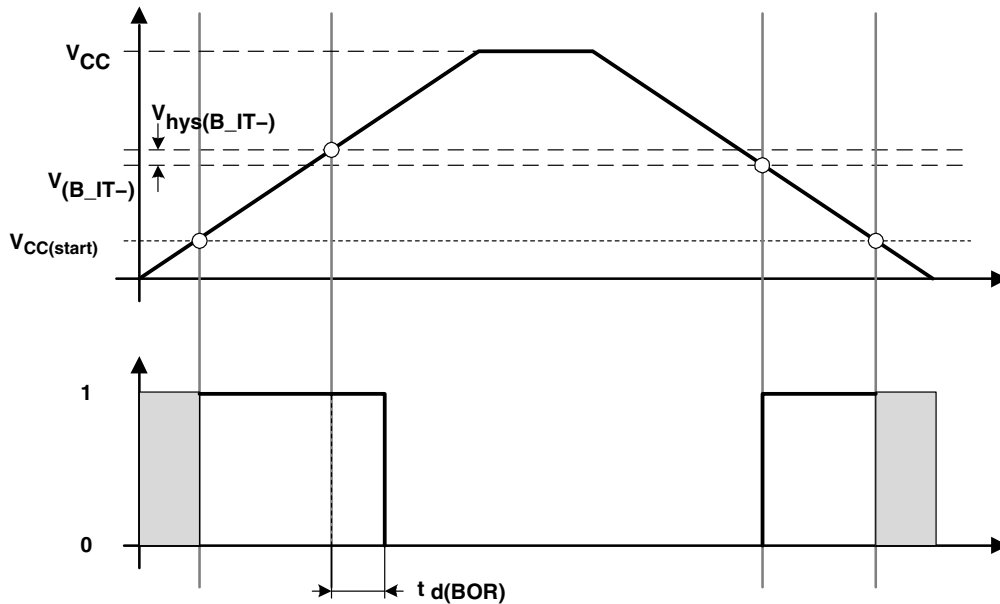

Figure 8. POR/Brownout Reset (BOR) vs Supply Voltage

electrical characteristics over recommended ranges of supply voltage and operating free-air temperature (unless otherwise noted) (continued)

typical characteristics – POR/brownout reset (BOR)

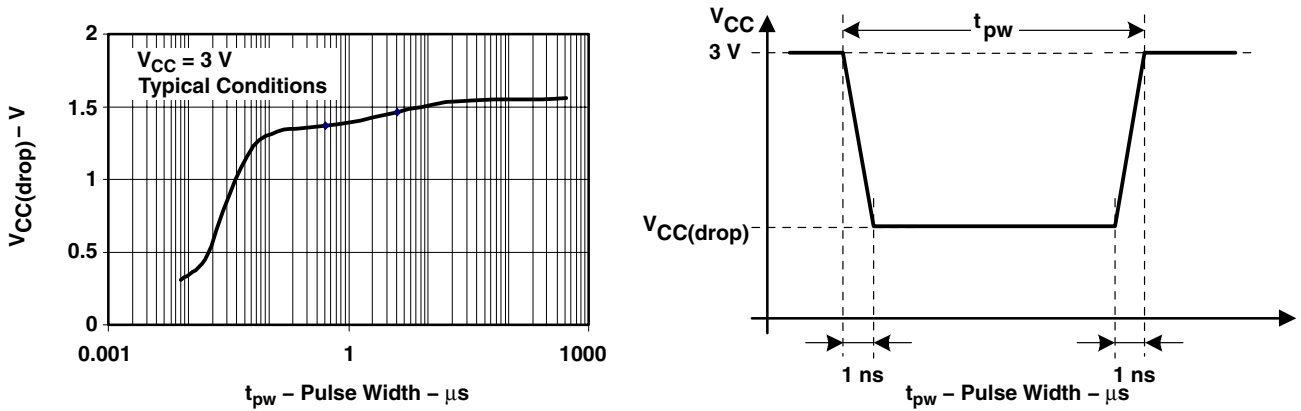

Figure 9.  $V_{CC(drop)}$  Level With a Square Voltage Drop to Generate a POR/Brownout Signal

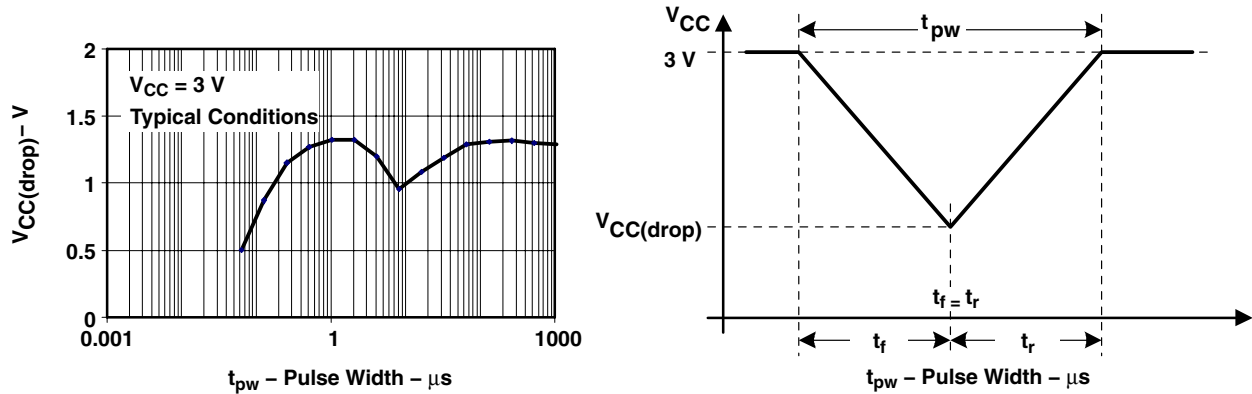

Figure 10.  $V_{CC(drop)}$  Level With a Triangle Voltage Drop to Generate a POR/Brownout Signal

# MSP430F471x6, MSP430F471x7 MIXED SIGNAL MICROCONTROLLER

SLAS626A – OCTOBER 2008 – REVISED MAY 2009

electrical characteristics over recommended ranges of supply voltage and operating free-air temperature (unless otherwise noted) (continued)

## SVS (supply voltage supervisor/monitor) (see Note 1)

PARAMETER	TEST CONDITIONS	MIN	TYP	MAX	UNIT	
$t_{(SVSR)}$	$dV_{CC}/dt > 30 \text{ V/ms}$ (see Figure 11)	5		150	$\mu\text{s}$	
	$dV_{CC}/dt \leq 30 \text{ V/ms}$			2000	$\mu\text{s}$	
$t_{d(SV\text{Son})}$	SVSon, switch from VLD = 0 to VLD $\neq$ 0, $V_{CC} = 3 \text{ V}$	20		200	$\mu\text{s}$	
$t_{\text{settle}}$	VLD $\neq$ 0 (see Note 2)			12	$\mu\text{s}$	
$V_{(SV\text{Sstart})}$	VLD $\neq$ 0, $V_{CC}/dt \leq 3 \text{ V/s}$ (see Figure 11)		1.55	1.7	V	
$V_{\text{hys}(SV\text{S\_IT-})}$	$V_{CC}/dt \leq 3 \text{ V/s}$ (see Figure 11)	VLD = 1	70	120	155	mV
		VLD = 2 to 14	$V_{(SV\text{S\_IT-})} \times 0.001$		$V_{(SV\text{S\_IT-})} \times 0.016$	
	$V_{CC}/dt \leq 3 \text{ V/s}$ (see Figure 11), External voltage applied on A7	VLD = 15	4.4		10.4	mV
$V_{(SV\text{S\_IT-})}$	$V_{CC}/dt \leq 3 \text{ V/s}$ (see Figure 11)	VLD = 1	1.8	1.9	2.05	V
		VLD = 2	1.94	2.1	2.25	
		VLD = 3	2.05	2.2	2.37	
		VLD = 4	2.14	2.3	2.48	
		VLD = 5	2.24	2.4	2.6	
		VLD = 6	2.33	2.5	2.71	
		VLD = 7	2.46	2.65	2.86	
		VLD = 8	2.58	2.8	3	
		VLD = 9	2.69	2.9	3.13	
		VLD = 10	2.83	3.05	3.29	
		VLD = 11	2.94	3.2	3.42	
		VLD = 12	3.11	3.35	3.61 <sup>†</sup>	
		VLD = 13	3.24	3.5	3.76 <sup>†</sup>	
		VLD = 14	3.43	3.7 <sup>†</sup>	3.99 <sup>†</sup>	
		$V_{CC}/dt \leq 3 \text{ V/s}$ (see Figure 11), External voltage applied on A7	VLD = 15	1.1	1.2	1.3
$I_{CC(SVS)}$ (see Note 1)	VLD $\neq$ 0, $V_{CC} = 2.2 \text{ V}/3 \text{ V}$		10	15	$\mu\text{A}$	

<sup>†</sup> The recommended operating voltage range is limited to 3.6 V.

NOTES: 1. The current consumption of the SVS module is not included in the  $I_{CC}$  current consumption data.

2.  $t_{\text{settle}}$  is the settling time that the comparator output needs to have a stable level after VLD is switched VLD  $\neq$  0 to a different VLD value somewhere between 2 and 15. The overdrive is assumed to be > 50 mV.

typical characteristics

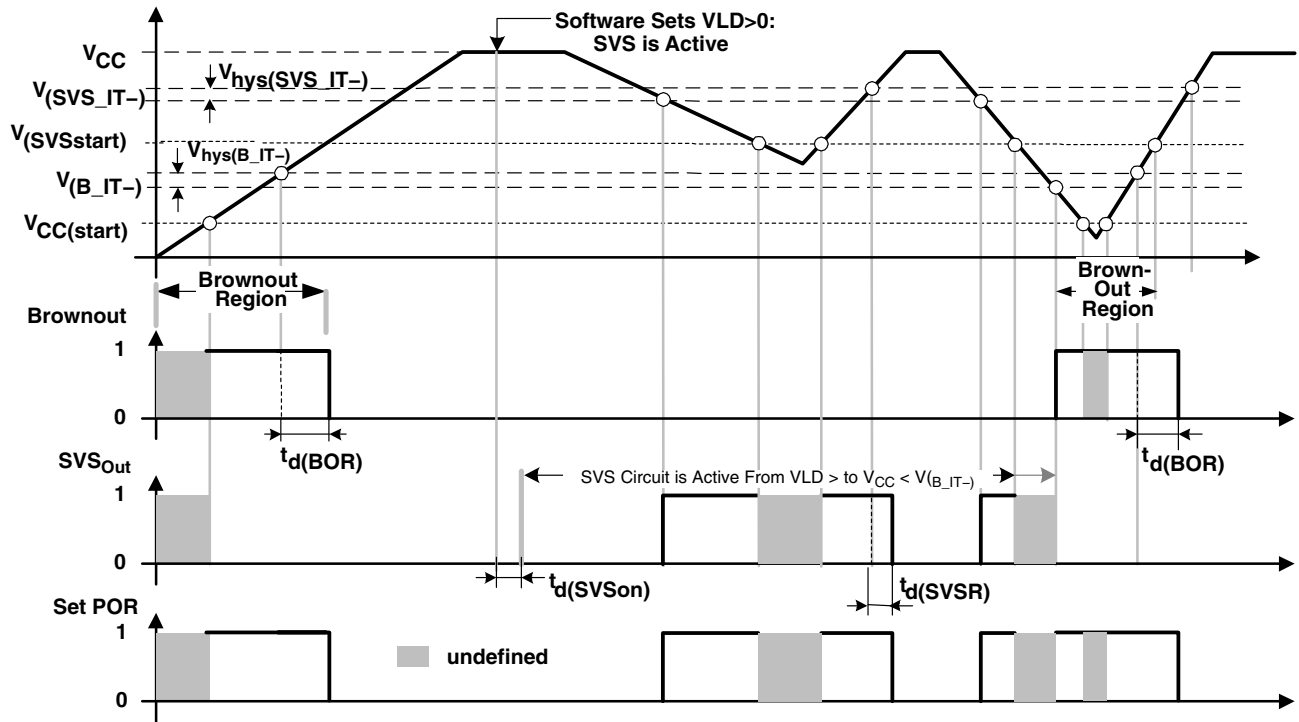

Figure 11. SVS Reset (SVSR) vs Supply Voltage

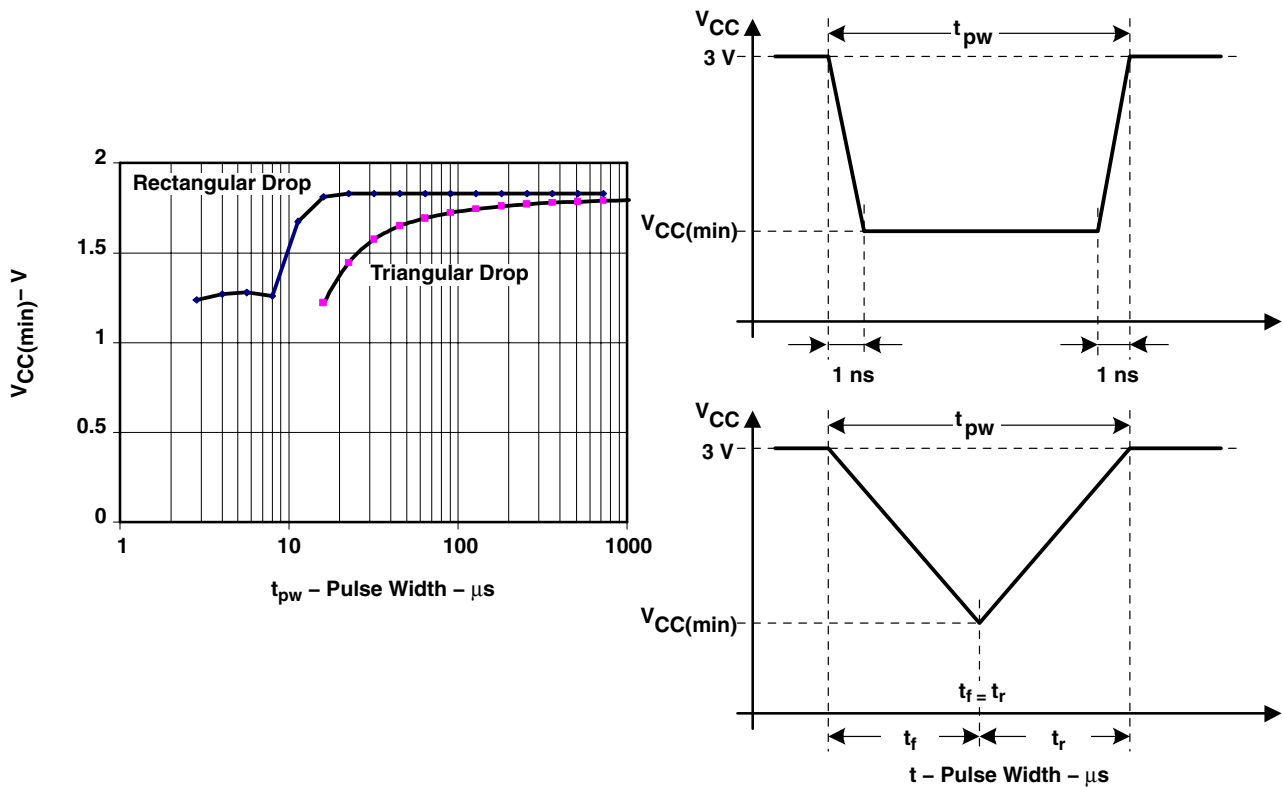

Figure 12.  $V_{CC(min)}$  With a Square Voltage Drop and a Triangle Voltage Drop to Generate an SVS Signal

# MSP430F471x6, MSP430F471x7 MIXED SIGNAL MICROCONTROLLER

SLAS626A – OCTOBER 2008 – REVISED MAY 2009

electrical characteristics over recommended operating free-air temperature (unless otherwise noted)

## DCO

PARAMETER	TEST CONDITIONS	MIN	TYP	MAX	UNIT			
$f_{(DCOCLK)}$	$N_{(DCO)} = 01Eh, FN_8 = FN_4 = FN_3 = FN_2 = 0, D = 2, DCOPLUS = 0$	$V_{CC} = 2.2\text{ V}/3\text{ V}$			1	MHz		
$f_{(DCO = 2)}$	$FN_8 = FN_4 = FN_3 = FN_2 = 0, DCOPLUS = 1$	$V_{CC} = 2.2\text{ V}$			0.3	0.65	1.25	MHz
		$V_{CC} = 3\text{ V}$			0.3	0.7	1.3	
$f_{(DCO = 27)}$	$FN_8 = FN_4 = FN_3 = FN_2 = 0, DCOPLUS = 1$	$V_{CC} = 2.2\text{ V}$			2.5	5.6	10.5	MHz
		$V_{CC} = 3\text{ V}$			2.7	6.1	11.3	
$f_{(DCO = 2)}$	$FN_8 = FN_4 = FN_3 = 0, FN_2 = 1, DCOPLUS = 1$	$V_{CC} = 2.2\text{ V}$			0.7	1.3	2.3	MHz
		$V_{CC} = 3\text{ V}$			0.8	1.5	2.5	
$f_{(DCO = 27)}$	$FN_8 = FN_4 = FN_3 = 0, FN_2 = 1, DCOPLUS = 1$	$V_{CC} = 2.2\text{ V}$			5.7	10.8	18	MHz
		$V_{CC} = 3\text{ V}$			6.5	12.1	20	
$f_{(DCO = 2)}$	$FN_8 = FN_4 = 0, FN_3 = 1, FN_2 = x, DCOPLUS = 1$	$V_{CC} = 2.2\text{ V}$			1.2	2	3	MHz
		$V_{CC} = 3\text{ V}$			1.3	2.2	3.5	
$f_{(DCO = 27)}$	$FN_8 = FN_4 = 0, FN_3 = 1, FN_2 = x, DCOPLUS = 1$	$V_{CC} = 2.2\text{ V}$			9	15.5	25	MHz
		$V_{CC} = 3\text{ V}$			10.3	17.9	28.5	
$f_{(DCO = 2)}$	$FN_8 = 0, FN_4 = 1, FN_3 = FN_2 = x, DCOPLUS = 1$	$V_{CC} = 2.2\text{ V}$			1.8	2.8	4.2	MHz
		$V_{CC} = 3\text{ V}$			2.1	3.4	5.2	
$f_{(DCO = 27)}$	$FN_8 = 0, FN_4 = 1, FN_3 = FN_2 = x, DCOPLUS = 1$	$V_{CC} = 2.2\text{ V}$			13.5	21.5	33	MHz
		$V_{CC} = 3\text{ V}$			16	26.6	41	
$f_{(DCO = 2)}$	$FN_8 = 1, FN_4 = FN_3 = FN_2 = x, DCOPLUS = 1$	$V_{CC} = 2.2\text{ V}$			2.8	4.2	6.2	MHz
		$V_{CC} = 3\text{ V}$			4.2	6.3	9.2	
$f_{(DCO = 27)}$	$FN_8 = 1, FN_4 = FN_3 = FN_2 = x, DCOPLUS = 1$	$V_{CC} = 2.2\text{ V}$			21	32	46	MHz
		$V_{CC} = 3\text{ V}$			30	46	70	
$S_n$	Step size between adjacent DCO taps: $S_n = f_{DCO(Tap\ n+1)} / f_{DCO(Tap\ n)}$ , (see Figure 14 for taps 21 to 27)	$1 < TAP \leq 20$			1.06		1.11	
		$TAP = 27$			1.07		1.17	
$D_t$	Temperature drift, $N_{(DCO)} = 01Eh, FN_8 = FN_4 = FN_3 = FN_2 = 0, D = 2, DCOPLUS = 0$	$V_{CC} = 2.2\text{ V}$			-0.2	-0.4	-0.6	%/°C
		$V_{CC} = 3\text{ V}$			-0.2	-0.4	-0.6	
$D_V$	Drift with $V_{CC}$ variation, $N_{(DCO)} = 01Eh, FN_8 = FN_4 = FN_3 = FN_2 = 0, D = 2, DCOPLUS = 0$	$V_{CC} = 2.2\text{ V}/3\text{ V}$			0	5	15	%/V

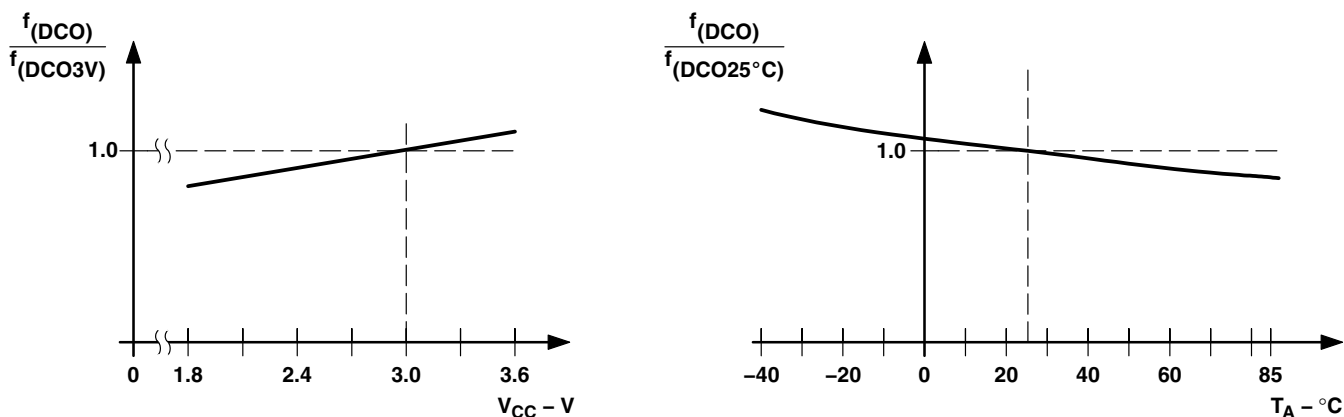

Figure 13. DCO Frequency vs Supply Voltage  $V_{CC}$  and vs Ambient Temperature



electrical characteristics over recommended operating free-air temperature (unless otherwise noted)

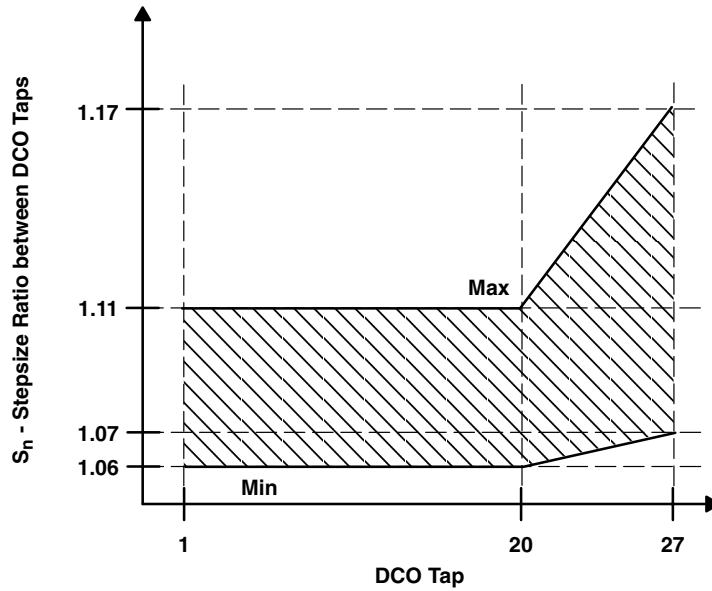

Figure 14. DCO Tap Step Size

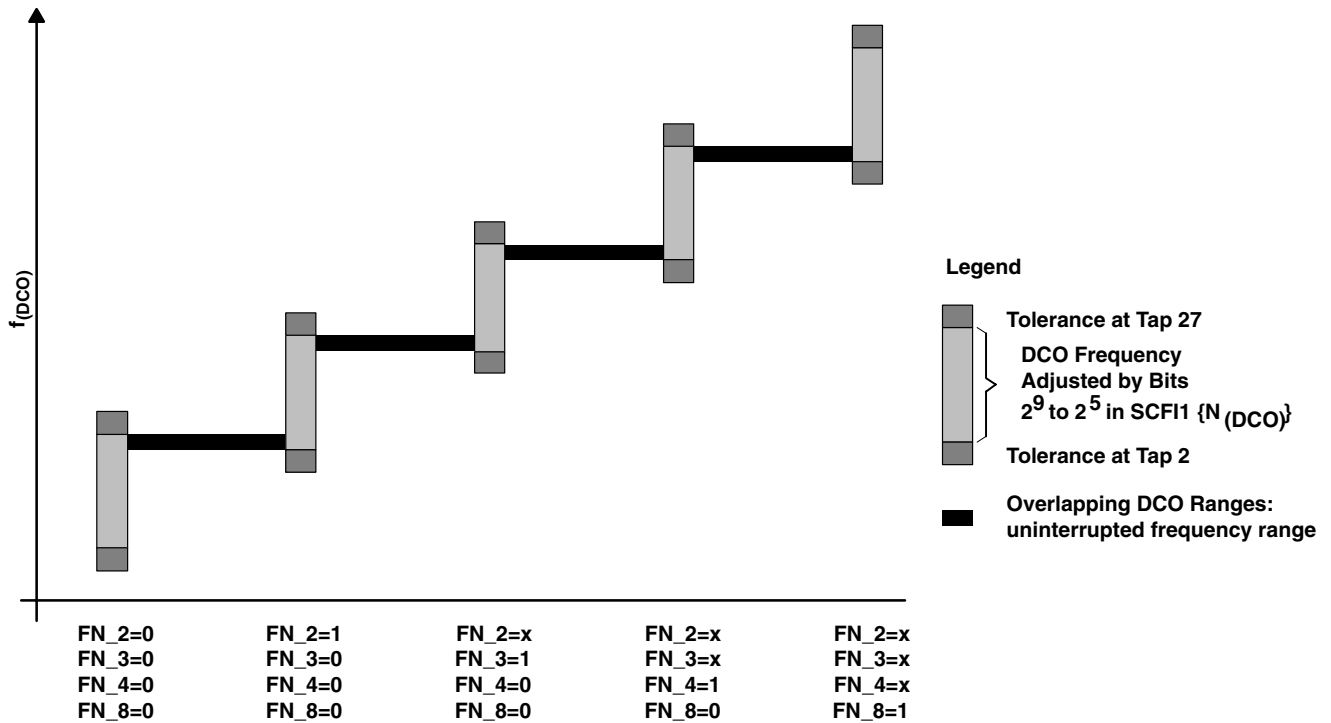

Figure 15. Five Overlapping DCO Ranges Controlled by FN\_x Bits

# MSP430F471x6, MSP430F471x7 MIXED SIGNAL MICROCONTROLLER

SLAS626A – OCTOBER 2008 – REVISED MAY 2009

## electrical characteristics over recommended operating free-air temperature (unless otherwise noted) (continued)

### crystal oscillator, LFXT1, low-frequency mode (see Note 4)

PARAMETER		TEST CONDITIONS	V <sub>CC</sub>	MIN	TYP	MAX	UNIT
f <sub>LFXT1,LF</sub>	LFXT1 oscillator crystal frequency, LF mode	XTS = 0	1.8 V to 3.6 V		32768		Hz
OA <sub>LF</sub>	Oscillation allowance for LF crystals	XTS = 0, LFXT1Sx = 0, f <sub>LFXT1,LF</sub> = 32768 Hz, C <sub>L,eff</sub> = 6 pF			500		kΩ
		XTS = 0, LFXT1Sx = 0, f <sub>LFXT1,LF</sub> = 32768 Hz, C <sub>L,eff</sub> = 12 pF			200		kΩ
C <sub>L,eff</sub>	Integrated effective load capacitance, LF mode (see Note 1)	XTS = 0, XCAPxPF = 0			1		pF
		XTS = 0, XCAPxPF = 1			5.5		pF
		XTS = 0, XCAPxPF = 2			8.5		pF
		XTS = 0, XCAPxPF = 3			11		pF
Duty Cycle	LF mode	XTS = 0, f <sub>LFXT1,LF</sub> = 32768 Hz Measured at P1.5/TACLK/ACLK	2.2 V/3 V	30	50	70	%
f <sub>Fault,LF</sub>	Oscillator fault frequency, LF mode (see Note 3)	XTS = 0 (see Note 2)	2.2 V/3 V	10		10,000	Hz

- NOTES: 1. Includes parasitic bond and package capacitance (approximately 2 pF per pin).  
Since the PCB adds additional capacitance it is recommended to verify the correct load by measuring the ACLK frequency. For a correct setup the effective load capacitance should always match the specification of the used crystal.
2. Measured with logic level input frequency but also applies to operation with crystals.
3. Frequencies below the MIN specification will set the fault flag, frequencies above the MAX specification will not set the fault flag. Frequencies in between might set the flag.
4. To improve EMI on the LFXT1 oscillator the following guidelines should be observed.
- Keep the trace between the device and the crystal as short as possible.
  - Design a good ground plane around the oscillator pins.
  - Prevent crosstalk from other clock or data lines into oscillator pins XIN and XOUT.
  - Avoid running PCB traces underneath or adjacent to the XIN and XOUT pins.
  - Use assembly materials and praxis to avoid any parasitic load on the oscillator XIN and XOUT pins.
  - If conformal coating is used, ensure that it does not induce capacitive/resistive leakage between the oscillator pins.
  - Do not route the XOUT line to the JTAG header to support the serial programming adapter as shown in other documentation. This signal is no longer required for the serial programming adapter.

### crystal oscillator, LFXT1, high-frequency mode

PARAMETER		TEST CONDITIONS	V <sub>CC</sub>	MIN	TYP	MAX	UNIT
f <sub>XT1</sub>	XT1 oscillator crystal frequency	XTS = 1, Ceramic resonator	1.8 V to 3.6 V	0.45		6	MHz
f <sub>XT1</sub>	XT1 oscillator crystal frequency	XTS = 1, Crystal	1.8 V to 3.6 V	1		6	MHz
C <sub>L,eff</sub>	Integrated effective load capacitance (see Note 1)	(see Note 2)			1		pF
Duty Cycle		Measured at P1.5/TACLK/ACLK	2.2 V/3 V	40	50	60	%

- NOTES: 1. Includes parasitic bond and package capacitance (approximately 2pF per pin).  
Since the PCB adds additional capacitance it is recommended to verify the correct load by measuring the ACLK frequency. For a correct setup the effective load capacitance should always match the specification of the used crystal.
2. Requires external capacitors at both terminals. Values are specified by crystal manufacturers.





electrical characteristics over recommended operating free-air temperature (unless otherwise noted) (continued)

crystal oscillator, XT2 oscillator (see Note 5)

PARAMETER		TEST CONDITIONS	V <sub>CC</sub>	MIN	TYP	MAX	UNIT
f <sub>XT2,0</sub>	XT2 oscillator crystal frequency, mode 0	XT2Sx = 0	1.8 V to 3.6 V	0.4		1	MHz
f <sub>XT2,1</sub>	XT2 oscillator crystal frequency, mode 1	XT2Sx = 1	1.8 V to 3.6 V	1		4	MHz
f <sub>XT2,2</sub>	XT2 oscillator crystal frequency, mode 2	XT2Sx = 2	1.8 V to 3.6 V	2		10	MHz
			2.2 V to 3.6 V	2		12	MHz
			3.0 V to 3.6 V	2		16	MHz
f <sub>XT2,logic</sub>	XT2 oscillator logic level square wave input frequency	XT2Sx = 3	1.8 V to 3.6 V	0.4		10	MHz
			2.2 V to 3.6 V	0.4		12	MHz
			3.0 V to 3.6 V	0.4		16	MHz
OA <sub>XT2</sub>	Oscillation allowance for HF crystals (see Figure 16)	XT2Sx = 0, f <sub>XT2</sub> = 1 MHz, C <sub>L,eff</sub> = 15 pF			2700		Ω
		XT2Sx = 1 f <sub>XT2</sub> = 4 MHz, C <sub>L,eff</sub> = 15 pF			800		Ω
		XT2Sx = 2 f <sub>XT2</sub> = 16 MHz, C <sub>L,eff</sub> = 15 pF			300		Ω
C <sub>L,eff</sub>	Integrated effective load capacitance (see Note 1)	(see Note 2)			1		pF
Duty cycle		Measured at P1.5/TACLK/ACLK, f <sub>XT2</sub> = 10 MHz	2.2 V/3 V	40	50	60	%
		Measured at P1.5/TACLK/ACLK, f <sub>XT2</sub> = 16 MHz	2.2 V/3 V	40	50	60	%
f <sub>Fault,XT2</sub>	Oscillator fault frequency (see Note 4)	XT2Sx = 3 (see Notes 3)	2.2 V/3 V	30		300	kHz

- NOTES:
- Includes parasitic bond and package capacitance (approximately 2pF per pin).  
Since the PCB adds additional capacitance it is recommended to verify the correct load by measuring the frequency. For a correct setup the effective load capacitance should always match the specification of the used crystal.
  - Requires external capacitors at both terminals. Values are specified by crystal manufacturers.
  - Measured with logic level input frequency but also applies to operation with crystals.
  - Frequencies below the MIN specification will set the fault flag, frequencies above the MAX specification will not set the fault flag. Frequencies in between might set the flag.
  - To improve EMI on the XT2 oscillator the following guidelines should be observed.
    - Keep the trace between the device and the crystal as short as possible.
    - Design a good ground plane around the oscillator pins.
    - Prevent crosstalk from other clock or data lines into oscillator pins XT2IN and XT2OUT.
    - Avoid running PCB traces underneath or adjacent to the XT2IN and XT2OUT pins.
    - Use assembly materials and praxis to avoid any parasitic load on the oscillator XT2IN and XT2OUT pins.
    - If conformal coating is used, ensure that it does not induce capacitive/resistive leakage between the oscillator pins.

# MSP430F471x6, MSP430F471x7 MIXED SIGNAL MICROCONTROLLER

SLAS626A – OCTOBER 2008 – REVISED MAY 2009

electrical characteristics over recommended ranges of supply voltage and operating free-air temperature (unless otherwise noted) (continued)

typical characteristics – XT2 oscillator

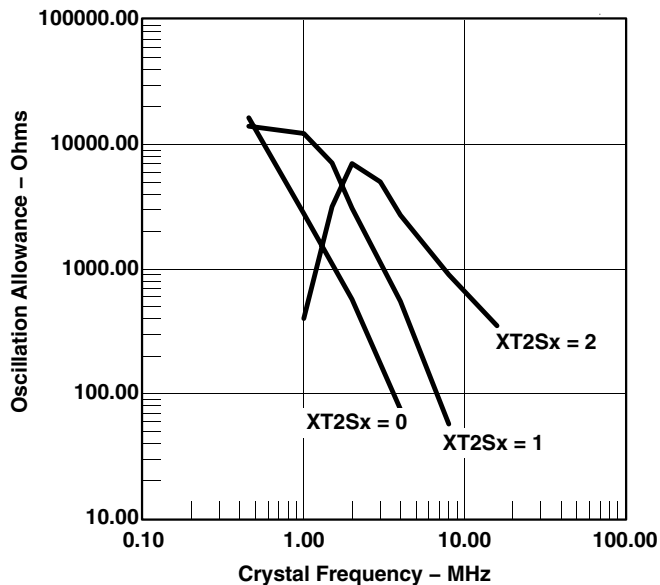

Figure 16. Oscillation Allowance vs Crystal Frequency,  $C_{L,eff} = 15 \text{ pF}$ ,  $T_A = 25^\circ\text{C}$

electrical characteristics over recommended operating free-air temperature (unless otherwise noted) (continued)

wake-up LPM3

PARAMETER		TEST CONDITIONS		MIN	MAX	UNIT
$t_{d(LPM3)}$	Delay time	f = 1 MHz	$V_{CC} = 2.2 \text{ V}/3 \text{ V}$		6	$\mu\text{s}$
		f = 2 MHz		6		
		f = 3 MHz		6		

LCD\_A

PARAMETER		TEST CONDITIONS	$V_{CC}$	MIN	TYP	MAX	UNIT
$V_{CC(LCD)}$	Supply voltage range	Charge pump enabled (LCDCPEN = 1, VLCDx > 0000)		2.2		3.6	V
$C_{LCD}$	Capacitor on LCDCAP (see Note 1)	Charge pump enabled (LCDCPEN = 1, VLCDx > 0000)		4.7			$\mu\text{F}$
$I_{CC(LCD)}$	Supply current	$V_{LCD(typ)} = 3 \text{ V}$ , LCDCPEN = 1, VLCDx = 1000, all segments on, $f_{LCD} = f_{ACLK}/32$ no LCD connected (see Note 2), $T_A = 25^\circ\text{C}$	2.2 V		3.8		$\mu\text{A}$
$f_{LCD}$	LCD frequency					1.1	kHz
$V_{LCD}$	LCD voltage	VLCDx = 0000			$V_{CC}$		V
$V_{LCD}$	LCD voltage	VLCDx = 0001			2.60		V
$V_{LCD}$	LCD voltage	VLCDx = 0010			2.66		V
$V_{LCD}$	LCD voltage	VLCDx = 0011			2.72		V
$V_{LCD}$	LCD voltage	VLCDx = 0100			2.78		V
$V_{LCD}$	LCD voltage	VLCDx = 0101			2.84		V
$V_{LCD}$	LCD voltage	VLCDx = 0110			2.90		V
$V_{LCD}$	LCD voltage	VLCDx = 0111			2.96		V
$V_{LCD}$	LCD voltage	VLCDx = 1000			3.02		V
$V_{LCD}$	LCD voltage	VLCDx = 1001			3.08		V
$V_{LCD}$	LCD voltage	VLCDx = 1010			3.14		V
$V_{LCD}$	LCD voltage	VLCDx = 1011			3.20		V
$V_{LCD}$	LCD voltage	VLCDx = 1100			3.26		V
$V_{LCD}$	LCD voltage	VLCDx = 1101			3.32		V
$V_{LCD}$	LCD voltage	VLCDx = 1110			3.38		V
$V_{LCD}$	LCD voltage	VLCDx = 1111			3.44	3.60	V
$R_{LCD}$	LCD driver output impedance	$V_{LCD} = 3 \text{ V}$ , LCDCPEN = 1, VLCDx = 1000, $I_{LOAD} = \pm 10 \mu\text{A}$	2.2 V			10	k $\Omega$

- NOTES: 1. Enabling the internal charge pump with an external capacitor smaller than the minimum specified might damage the device.  
2. Connecting an actual display will increase the current consumption depending on the size of the LCD.

# MSP430F471x6, MSP430F471x7 MIXED SIGNAL MICROCONTROLLER

SLAS626A – OCTOBER 2008 – REVISED MAY 2009

## electrical characteristics over recommended operating free-air temperature (unless otherwise noted) (continued)

### Comparator\_A (see Note 1)

PARAMETER	TEST CONDITIONS	V <sub>CC</sub>	MIN	TYP	MAX	UNIT
I <sub>(CC)</sub>	CAON = 1, CARSEL = 0, CAREF = 0	2.2 V		25	40	μA
		3 V		45	60	
I <sub>(RefLadder/RefDiode)</sub>	CAON = 1, CARSEL = 0, CAREF = 1/2/3, No load at P2.6/CA0 and P2.7/CA1	2.2 V		30	50	μA
		3 V		45	80	
V <sub>(Ref025)</sub>	$\frac{\text{Voltage @ } 0.25 V_{CC} \text{ node}}{V_{CC}}$ PCA0 = 1, CARSEL = 1, CAREF = 1, No load at P2.6/CA0 and P2.7/CA1	2.2 V / 3 V	0.23	0.24	0.25	
V <sub>(Ref050)</sub>	$\frac{\text{Voltage @ } 0.5 V_{CC} \text{ node}}{V_{CC}}$ PCA0 = 1, CARSEL = 1, CAREF = 2, No load at P2.6/CA0 and P2.7/CA1	2.2V / 3 V	0.47	0.48	0.5	
V <sub>(RefVT)</sub>	See Figure 17 and Figure 18 PCA0 = 1, CARSEL = 1, CAREF = 3, No load at P2.6/CA0 and P2.7/CA1, T <sub>A</sub> = 85°C	2.2 V	390	480	540	mV
		3 V	400	490	550	
V <sub>IC</sub>	Common-mode input voltage range CAON = 1	2.2 V / 3 V	0		V <sub>CC</sub> -1	V
V <sub>p</sub> -V <sub>S</sub>	Offset voltage See Note 2	2.2 V / 3 V	-30		30	mV
V <sub>hys</sub>	Input hysteresis CAON = 1	2.2 V / 3 V	0	0.7	1.4	mV
t <sub>(response LH and HL)</sub> (See Note 3)	T <sub>A</sub> = 25°C, Overdrive 10 mV, without filter: CAF = 0	2.2 V	80	165	300	ns
		3 V	70	120	240	
	T <sub>A</sub> = 25°C Overdrive 10 mV, with filter: CAF = 1	2.2 V	1.4	1.9	2.8	μs
		3 V	0.9	1.5	2.2	

- NOTES: 1. The leakage current for the Comparator\_A terminals is identical to I<sub>lkg(Px.x)</sub> specification.  
 2. The input offset voltage can be cancelled by using the CAEX bit to invert the Comparator\_A inputs on successive measurements. The two successive measurements are then summed together.  
 3. The response time is measured at P2.6/CA0 with an input voltage step and the Comparator\_A already enabled (CAON = 1). If CAON is set at the same time, a settling time of up to 300 ns is added to the response time.



electrical characteristics over recommended operating free-air temperature (unless otherwise noted) (continued)

typical characteristics

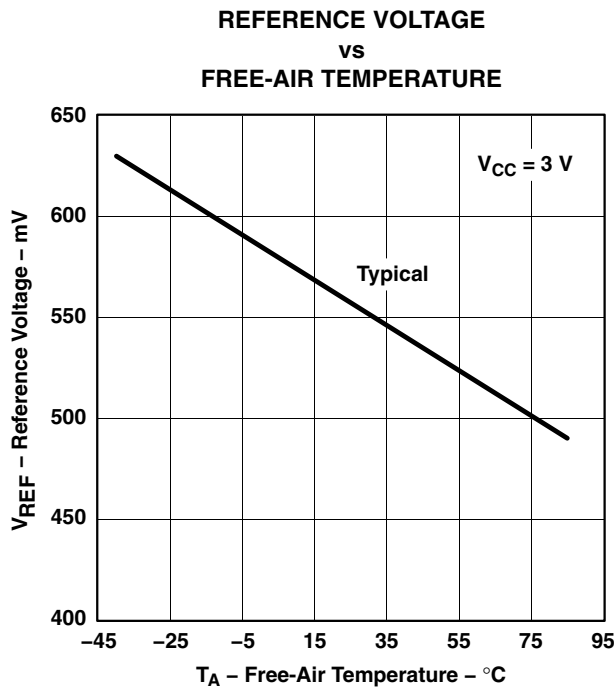

Figure 17. V<sub>(RefVT)</sub> vs Temperature

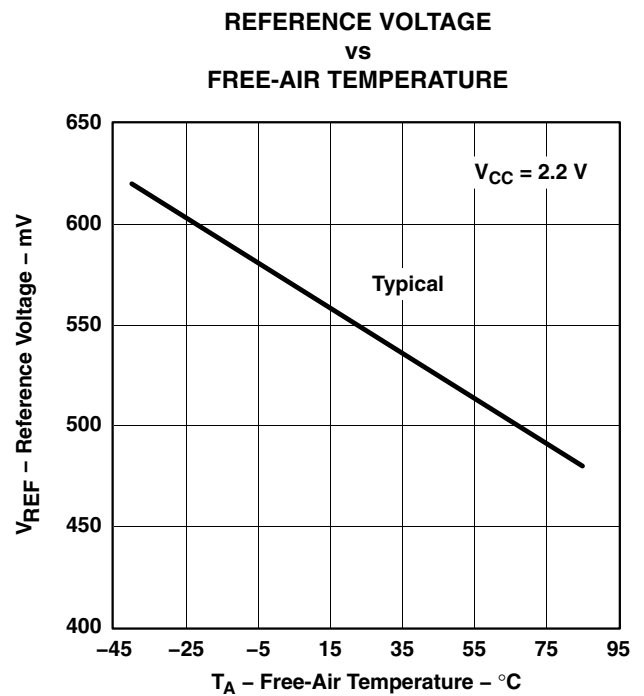

Figure 18. V<sub>(RefVT)</sub> vs Temperature

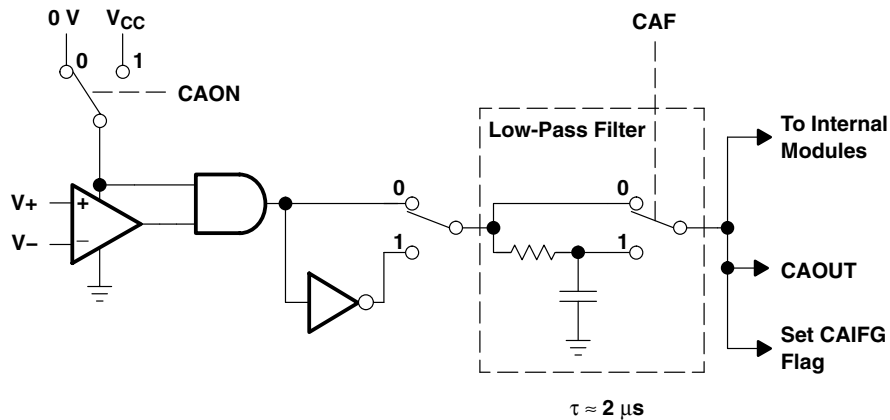

Figure 19. Block Diagram of Comparator\_A Module

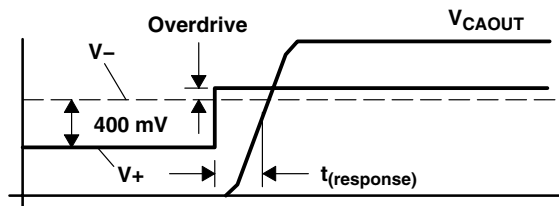

Figure 20. Overdrive Definition

# MSP430F471x6, MSP430F471x7 MIXED SIGNAL MICROCONTROLLER

SLAS626A – OCTOBER 2008 – REVISED MAY 2009

electrical characteristics over recommended ranges of supply voltage and operating free-air temperature (unless otherwise noted) (continued)

## Timer\_A

PARAMETER		TEST CONDITIONS	V <sub>CC</sub>	MIN	MAX	UNIT
f <sub>TA</sub>	Timer_A clock frequency	Internal: SMCLK, ACLK, External: TACLK, INCLK, Duty cycle = 50% ±10%	2.2 V		10	MHz
			3 V		16	
t <sub>TA,cap</sub>	Timer_A, capture timing	TA0, TA1, TA2	2.2 V/3 V	20		ns

## Timer\_B

PARAMETER		TEST CONDITIONS	V <sub>CC</sub>	MIN	MAX	UNIT
f <sub>TB</sub>	Timer_B clock frequency	Internal: SMCLK, ACLK, External: TBCLK, Duty cycle = 50% ±10%	2.2 V		10	MHz
			3 V		16	
t <sub>TB,cap</sub>	Timer_B, capture timing	TB0, TB1, TB2	2.2 V/3 V	20		ns



**electrical characteristics over recommended ranges of supply voltage and operating free-air temperature (unless otherwise noted) (continued)**

**USCI (UART mode) – recommended operating conditions**

PARAMETER		CONDITIONS	MIN	MAX	UNIT
f <sub>USCI</sub>	USCI input clock frequency	Internal: SMCLK, ACLK External: UCLK Duty cycle = 50% ± 10%		f <sub>SYSTEM</sub>	MHz
f <sub>BITCLK</sub>	BITCLK clock frequency (equals baud rate in MBaud)			1	MHz

**USCI (UART mode)**

PARAMETER		TEST CONDITIONS	V <sub>CC</sub>	MIN	TYP	MAX	UNIT
t <sub>τ</sub>	UART receive deglitch time (see Note 1)		2.2 V	50	150	600	ns
			3 V	50	100	600	ns

NOTES: 1. Pulses on the UART receive input (UCxRX) shorter than the UART receive deglitch time are suppressed. To ensure that pulses are correctly recognized their width should exceed the maximum specification of the deglitch time.

**USCI (SPI master mode) – recommended operating conditions**

PARAMETER		CONDITIONS	MIN	MAX	UNIT
f <sub>USCI</sub>	USCI input clock frequency	SMCLK, ACLK Duty cycle = 50% ± 10%		f <sub>SYSTEM</sub>	MHz

**USCI (SPI master mode) (see Note 1, Figure 21, and Figure 22)**

PARAMETER		TEST CONDITIONS	V <sub>CC</sub>	MIN	MAX	UNIT
f <sub>USCI</sub>	USCI input clock frequency	SMCLK, ACLK Duty cycle = 50% ± 10%		f <sub>SYSTEM</sub>	MHz	
t <sub>SU,MI</sub>	SOMI input data setup time		2.2 V	110		ns
			3 V	75		ns
t <sub>HD,MI</sub>	SOMI input data hold time		2.2 V	0		ns
			3 V	0		ns
t <sub>VALID,MO</sub>	SIMO output data valid time (Note 2)	UCLK edge to SIMO valid, C <sub>L</sub> = 20 pF	2.2 V		30	ns
			3 V		20	ns
t <sub>HD,MO</sub>	SIMO output data hold time (Note 3)	C <sub>L</sub> = 20 pF	2.2 V	0		ns
			3 V	0		ns

NOTES: 1.  $f_{UCxCLK} = \frac{1}{2t_{LO/HI}}$  with  $t_{LO/HI} \geq \max(t_{VALID,MO(USCI)} + t_{SU,SI(Slave)}, t_{SU,MI(USCI)} + t_{VALID,SO(Slave)})$ .

For the slave's parameters t<sub>SU,SI(Slave)</sub> and t<sub>VALID,SO(Slave)</sub> refer to the SPI parameters of the attached slave.

- Specifies the time to drive the next valid data to the SIMO output after the output changing UCLK clock edge. Refer to the timing diagrams in Figure 21 and Figure 22.
- Specifies how long data on the SIMO output is valid after the output changing UCLK clock edge. Negative values indicate that the data on the SIMO output can become invalid before the output changing clock edge observed on UCLK. Refer to the timing diagrams in Figure 21 and Figure 22.

# MSP430F471x6, MSP430F471x7 MIXED SIGNAL MICROCONTROLLER

SLAS626A – OCTOBER 2008 – REVISED MAY 2009

electrical characteristics over recommended ranges of supply voltage and operating free-air temperature (unless otherwise noted) (continued)

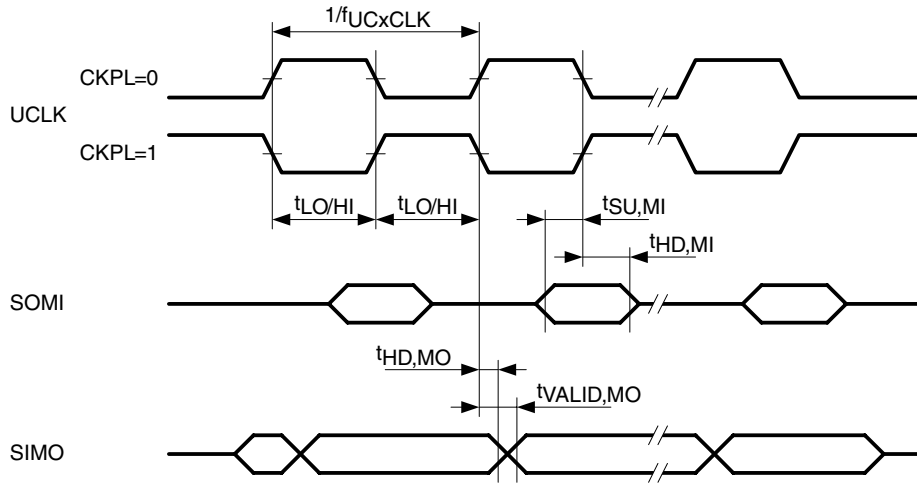

Figure 21. SPI Master Mode, CKPH = 0

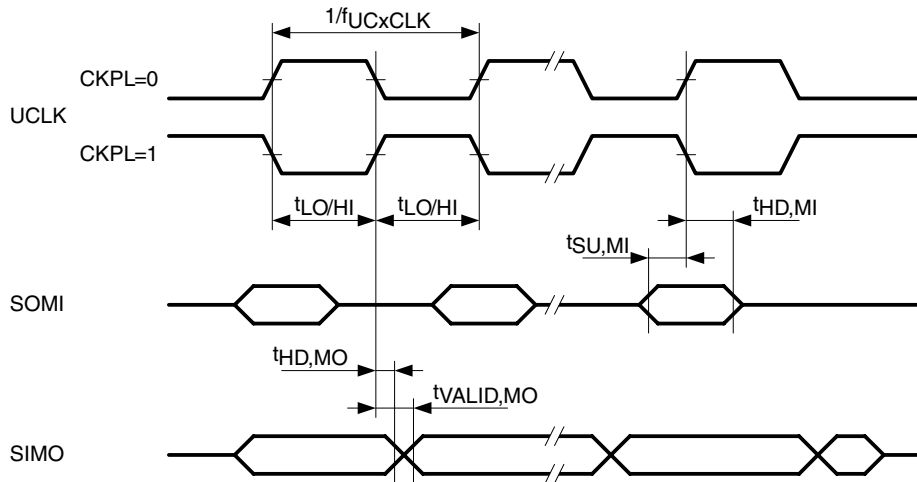

Figure 22. SPI Master Mode, CKPH = 1



electrical characteristics over recommended ranges of supply voltage and operating free-air temperature (unless otherwise noted) (continued)

USCI (SPI slave mode) (see Note 1, Figure 23, and Figure 24)

PARAMETER		TEST CONDITIONS	V <sub>CC</sub>	MIN	TYP	MAX	UNIT
t <sub>STE,LEAD</sub>	STE lead time STE low to clock		2.2 V/3 V		50		ns
t <sub>STE,LAG</sub>	STE lag time Last clock to STE high		2.2 V/3 V	10			ns
t <sub>STE,ACC</sub>	STE access time STE low to SOMI data out		2.2 V/3 V		50		ns
t <sub>STE,DIS</sub>	STE disable time STE high to SOMI high impedance		2.2 V/3 V		50		ns
t <sub>SU,SI</sub>	SIMO input data setup time		2.2 V	20			ns
			3 V	15			ns
t <sub>HD,SI</sub>	SIMO input data hold time		2.2 V	10			ns
			3 V	10			ns
t <sub>VALID,SO</sub>	SOMI output data valid time (Note 2)	UCLK edge to SOMI valid, C <sub>L</sub> = 20 pF	2.2 V		75	110	ns
			3 V		50	75	ns
t <sub>HD,MO</sub>	SOMI output data hold time (Note 3)	C <sub>L</sub> = 20 pF	2.2 V	0			ns
			3 V	0			ns

NOTES: 1.  $f_{UCxCLK} = \frac{1}{2t_{LO/HI}}$  with  $t_{LO/HI} \geq \max(t_{VALID,MO(Master)} + t_{SU,SI(USCI)}, t_{SU,MI(Master)} + t_{VALID,SO(USCI)})$ .

For the master's parameters t<sub>SU,MI(Master)</sub> and t<sub>VALID,MO(Master)</sub> refer to the SPI parameters of the attached master.

- Specifies the time to drive the next valid data to the SOMI output after the output changing UCLK clock edge. Refer to the timing diagrams in Figure 23 and Figure 24.
- Specifies how long data on the SOMI output is valid after the output changing UCLK clock edge. Negative values indicate that the data on the SOMI output can become invalid before the output changing clock edge observed on UCLK. Refer to the timing diagrams in Figure 23 and Figure 24.

# MSP430F471x6, MSP430F471x7 MIXED SIGNAL MICROCONTROLLER

SLAS626A – OCTOBER 2008 – REVISED MAY 2009

electrical characteristics over recommended ranges of supply voltage and operating free-air temperature (unless otherwise noted) (continued)

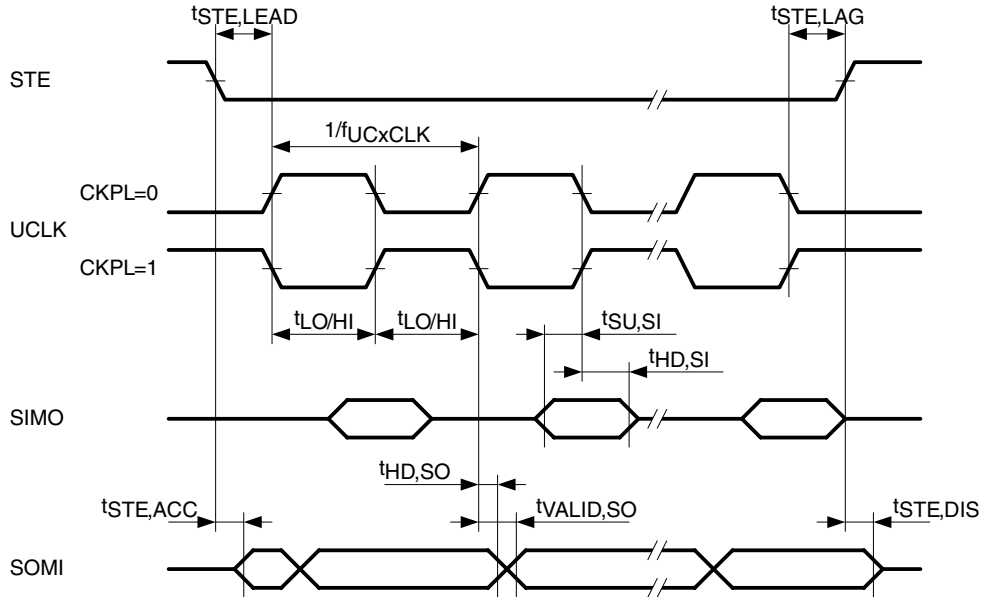

Figure 23. SPI Slave Mode, CKPH = 0

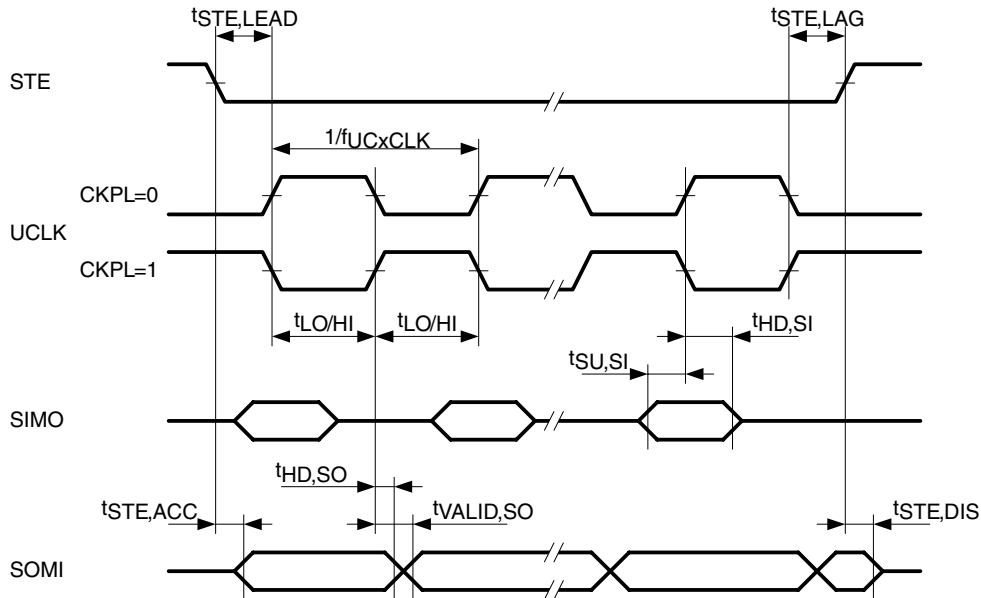

Figure 24. SPI Slave Mode, CKPH = 1

electrical characteristics over recommended ranges of supply voltage and operating free-air temperature (unless otherwise noted) (continued)

USCI (I2C mode) (see Figure 25)

PARAMETER	TEST CONDITIONS	V <sub>CC</sub>	MIN	TYP	MAX	UNIT	
f <sub>USCI</sub>	USCI input clock frequency	Internal: SMCLK, ACLK External: UCLK Duty cycle = 50% ± 10%		f <sub>SYSTEM</sub>		MHz	
f <sub>SCL</sub>	SCL clock frequency		0		400	kHz	
t <sub>HD,STA</sub>	Hold time (repeated) START	f <sub>SCL</sub> ≤ 100kHz (standard mode)	2.2 V/3 V	4.0		μs	
		f <sub>SCL</sub> > 100kHz (fast mode)	2.2 V/3 V	0.6		μs	
t <sub>SU,STA</sub>	Setup time for a repeated START	f <sub>SCL</sub> ≤ 100kHz (standard mode)	2.2 V/3 V	4.7		μs	
		f <sub>SCL</sub> > 100kHz (fast mode)	2.2 V/3 V	0.6		μs	
t <sub>HD,DAT</sub>	Data hold time		2.2 V/3 V	0		ns	
t <sub>SU,DAT</sub>	Data setup time		2.2 V/3 V	250		ns	
t <sub>SU,STO</sub>	Setup time for STOP	f <sub>SCL</sub> ≤ 100kHz (standard mode)	2.2 V/3 V	4.0		μs	
		f <sub>SCL</sub> > 100kHz (fast mode)	2.2 V/3 V	0.6		μs	
t <sub>SP</sub>	Pulse width of spikes suppressed by input filter	2.2 V		50	150	600	ns
		3 V		50	100	600	ns

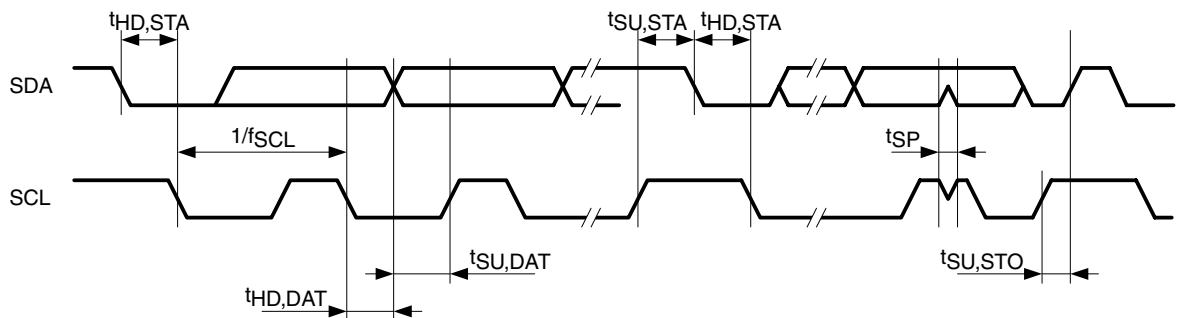

Figure 25. I2C Mode Timing

# MSP430F471x6, MSP430F471x7 MIXED SIGNAL MICROCONTROLLER

SLAS626A – OCTOBER 2008 – REVISED MAY 2009

## electrical characteristics over recommended operating free-air temperature (unless otherwise noted) (continued)

### SD16\_A, power supply and recommended operating conditions

PARAMETER		TEST CONDITIONS		V <sub>CC</sub>	MIN	TYP	MAX	UNIT
AV <sub>CC</sub>	Analog supply voltage	AV <sub>CC</sub> = DV <sub>CC</sub> AV <sub>SS</sub> = DV <sub>SS</sub> = 0V			2.5		3.6	V
I <sub>SD16</sub>	Analog supply current: 1 active SD16_A channel including internal reference	SD16LP = 0, f <sub>SD16</sub> = 1 MHz, SD16OSR = 256	GAIN: 1,2	3 V		800	1100	μA
			GAIN: 4,8,16	3 V		900	1200	
			GAIN: 32	3 V		1200	1700	
		SD16LP = 1, f <sub>SD16</sub> = 0.5 MHz, SD16OSR = 256	GAIN: 1	3 V		800	1100	
			GAIN: 32	3 V		900	1200	
f <sub>SD16</sub>	Analog front-end input clock frequency	SD16LP = 0 (low-power mode disabled)		3 V	0.03	1	1.1	MHz
		SD16LP = 1 (low-power mode enabled)		3 V	0.03	0.5		

### SD16\_A, input range (see Note 1)

PARAMETER		TEST CONDITIONS		V <sub>CC</sub>	MIN	TYP	MAX	UNIT
V <sub>ID,FSR</sub>	Differential full scale input voltage range	Bipolar mode, SD16UNI = 0			-V <sub>REF</sub> /2GAIN		+V <sub>REF</sub> /2GAIN	mV
		Unipolar mode, SD16UNI = 1			0		+V <sub>REF</sub> /2GAIN	mV
V <sub>ID</sub>	Differential input voltage range for specified performance (see Note 2)	SD16REFON = 1	SD16GAINx = 1			±500		mV
			SD16GAINx = 2			±250		
			SD16GAINx = 4			±125		
			SD16GAINx = 8			±62		
			SD16GAINx = 16			±31		
			SD16GAINx = 32			±15		
Z <sub>I</sub>	Input impedance (one input pin to AV <sub>SS</sub> )	f <sub>SD16</sub> = 1 MHz	SD16GAINx = 1	3 V		200		kΩ
			SD16GAINx = 32	3 V		75		
Z <sub>ID</sub>	Differential input impedance (IN+ to IN-)	f <sub>SD16</sub> = 1 MHz	SD16GAINx = 1	3 V	300	400		kΩ
			SD16GAINx = 32	3 V	100	150		
V <sub>I</sub>	Absolute input voltage range				AV <sub>SS</sub> -1V		AV <sub>CC</sub>	V
V <sub>IC</sub>	Common-mode input voltage range				AV <sub>SS</sub> -1V		AV <sub>CC</sub>	V

- NOTES: 1. All parameters pertain to each SD16\_A channel.  
 2. The full-scale range is defined by V<sub>FSR+</sub> = +(V<sub>REF</sub>/2)/GAIN and V<sub>FSR-</sub> = -(V<sub>REF</sub>/2)/GAIN.  
 If V<sub>REF</sub> is sourced externally, the analog input range should not exceed 80% of V<sub>FSR+</sub> or V<sub>FSR-</sub>; i.e., V<sub>ID</sub> = 0.8 V<sub>FSR-</sub> to 0.8 V<sub>FSR+</sub>.  
 If V<sub>REF</sub> is sourced internally, the given V<sub>ID</sub> ranges apply.



electrical characteristics over recommended operating free-air temperature (unless otherwise noted) (continued)

SD16\_A, performance ( $f_{SD16} = 1$  MHz, SD16OSRx = 256, SD16REFON = 1)

PARAMETER		TEST CONDITIONS	V <sub>CC</sub>	MIN	TYP	MAX	UNIT
SINAD	Signal-to-noise + distortion ratio	SD16GAINx = 1, Signal amplitude V <sub>PP</sub> = 500 mV	3 V	83	85		dB
		SD16GAINx = 2, Signal amplitude V <sub>PP</sub> = 250 mV					
		SD16GAINx = 4, Signal amplitude V <sub>PP</sub> = 125 mV					
		SD16GAINx = 8, Signal amplitude V <sub>PP</sub> = 62 mV					
		SD16GAINx = 16, Signal amplitude V <sub>PP</sub> = 31 mV					
		SD16GAINx = 32, Signal amplitude V <sub>PP</sub> = 15 mV					
G	Nominal gain	SD16GAINx = 1	3 V	0.97	1.00	1.02	
		SD16GAINx = 2	3 V	1.90	1.96	2.02	
		SD16GAINx = 4	3 V	3.76	3.86	3.96	
		SD16GAINx = 8	3 V	7.36	7.62	7.84	
		SD16GAINx = 16	3 V	14.56	15.04	15.52	
		SD16GAINx = 32	3 V	27.20	28.35	29.76	
E <sub>OS</sub>	Offset error	SD16GAINx = 1	3 V			±0.2	%FSR
		SD16GAINx = 32	3 V			±1.5	
dE <sub>OS</sub> /dT	Offset error temperature coefficient	SD16GAINx = 1	3 V		±4	±20	ppm FSR/°C
		SD16GAINx = 32	3 V		±20	±100	
CMRR	Common-mode rejection ratio	SD16GAINx = 1, Common-mode input signal: V <sub>ID</sub> = 500 mV, f <sub>IN</sub> = 50 Hz, 100 Hz	3 V		>90		dB
		SD16GAINx = 32, Common-mode input signal: V <sub>ID</sub> = 16 mV, f <sub>IN</sub> = 50 Hz, 100 Hz	3 V		>75		
AC PSRR	AC power supply rejection ratio	SD16GAINx = 1, V <sub>CC</sub> = 3 V ± 100 mV, f <sub>VCC</sub> = 50 Hz	3 V		>80		dB
X <sub>T</sub>	Crosstalk	SD16GAINx = 1, V <sub>ID</sub> = 500 mV, f <sub>IN</sub> = 50 Hz, 100 Hz	3 V		<-100		dB

NOTE 1: The following voltages were applied to the SD16\_A inputs:

$$V_{IN,A+}(t) = 0V + V_{PP}/2 \times \sin(2\pi \times f_{IN} \times t)$$

$$V_{IN,A-}(t) = 0V - V_{PP}/2 \times \sin(2\pi \times f_{IN} \times t)$$

$$\text{resulting in a differential voltage of } V_{diff} = V_{IN,A+}(t) - V_{IN,A-}(t) = V_{PP} \times \sin(2\pi \times f_{IN} \times t)$$

# MSP430F471x6, MSP430F471x7 MIXED SIGNAL MICROCONTROLLER

SLAS626A – OCTOBER 2008 – REVISED MAY 2009

electrical characteristics over recommended operating free-air temperature (unless otherwise noted) (continued)

typical characteristics – SD16\_A SINAD performance over OSR

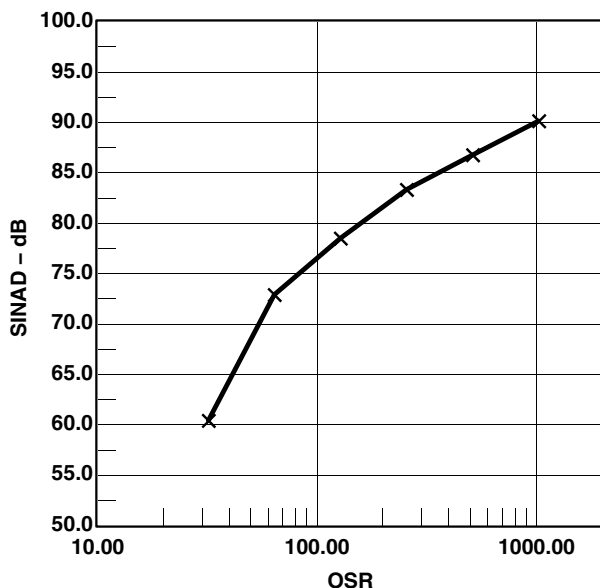

Figure 26. SINAD performance over OSR,  $f_{SD16} = 1$  MHz, SD16REFON = 1, SD16GAINx = 1

## SD16\_A, temperature sensor and built-in $V_{CC}$ sense

PARAMETER		TEST CONDITIONS	$V_{CC}$	MIN	TYP	MAX	UNIT
$TC_{Sensor}$	Sensor temperature coefficient			1.18	1.32	1.46	mV/K
$V_{Offset,sensor}$	Sensor offset voltage			-100		100	mV
$V_{Sensor}$	Sensor output voltage (see Note 2)	Temperature sensor voltage at $T_A = 85^\circ C$	3 V	435	475	515	mV
		Temperature sensor voltage at $T_A = 25^\circ C$	3 V	355	395	435	
		Temperature sensor voltage at $T_A = 0^\circ C$	3 V	320	360	400	
$V_{CC,Sense}$	$V_{CC}$ divider at input 5	$f_{SD16} = 1$ MHz, SD16OSRx = 256, SD16REFON = 1		0.08	1/11	0.1	$V_{CC}$
$R_{Source,VCC}$	Source resistance of $V_{CC}$ divider at input 5				20		k $\Omega$

- NOTES: 1. The following formula can be used to calculate the temperature sensor output voltage:  
 $V_{Sensor,typ} = TC_{Sensor} ( 273 + T [^\circ C] ) + V_{Offset,sensor}$  [mV]  
 2. Results based on characterization and/or production test, not  $TC_{Sensor}$  or  $V_{Offset,sensor}$ .  
 Measured with  $f_{SD16} = 1$  MHz, SD16OSRx = 256, SD16REFON = 1.



electrical characteristics over recommended operating free-air temperature (unless otherwise noted) (continued)

SD16\_A, built-in voltage reference

PARAMETER		TEST CONDITIONS	V <sub>CC</sub>	MIN	TYP	MAX	UNIT
V <sub>REF</sub>	Internal reference voltage	SD16REFON = 1, SD16VMIDON = 0	3 V	1.14	1.20	1.26	V
I <sub>REF</sub>	Reference supply current	SD16REFON = 1, SD16VMIDON = 0	3 V		175	260	μA
TC	Temperature coefficient	SD16REFON = 1, SD16VMIDON = 0 (see Note 1)	3 V		18	50	ppm/°C
C <sub>REF</sub>	V <sub>REF</sub> load capacitance	SD16REFON = 1, SD16VMIDON = 0 (see Note 2)			100		nF
I <sub>LOAD</sub>	V <sub>REF(I)</sub> maximum load current	SD16REFON = 1, SD16VMIDON = 0	3 V			±200	nA
t <sub>ON</sub>	Turn-on time	SD16REFON = 0→1, SD16VMIDON = 0, C <sub>REF</sub> = 100nF	3 V		5		ms
DC PSR	DC power supply rejection ΔV <sub>REF</sub> /ΔV <sub>CC</sub>	SD16REFON = 1, SD16VMIDON = 0, V <sub>CC</sub> = 2.5 V to 3.6 V			100		uV/V

- NOTES: 1. Calculated using the box method: (MAX(-40...85°C) – MIN(-40...85°C)) / MIN(-40...85°C) / (85°C – (-40°C))  
2. There is no capacitance required on V<sub>REF</sub>. However, a capacitance of at least 100 nF is recommended to reduce any reference voltage noise.

SD16\_A, reference output buffer

PARAMETER		TEST CONDITIONS	V <sub>CC</sub>	MIN	TYP	MAX	UNIT
V <sub>REF,BUF</sub>	Reference buffer output voltage	SD16REFON = 1, SD16VMIDON = 1	3 V		1.2		V
I <sub>REF,BUF</sub>	Reference supply + reference output buffer quiescent current	SD16REFON = 1, SD16VMIDON = 1	3 V		385	600	μA
C <sub>REF(O)</sub>	Required load capacitance on V <sub>REF</sub>	SD16REFON = 1, SD16VMIDON = 1		470			nF
I <sub>LOAD,Max</sub>	Maximum load current on V <sub>REF</sub>	SD16REFON = 1, SD16VMIDON = 1	3 V			±1	mA
	Maximum voltage variation vs load current	I <sub>LOAD</sub>   = 0 to 1mA	3 V	-15		+15	mV
t <sub>ON</sub>	Turn-on time	SD16REFON = 0→1, SD16VMIDON = 0→1, C <sub>REF</sub> = 470nF	3 V		100		μs

SD16\_A, external reference input

PARAMETER		TEST CONDITIONS	V <sub>CC</sub>	MIN	TYP	MAX	UNIT
V <sub>REF(I)</sub>	Input voltage range	SD16REFON = 0	3 V	1.0	1.25	1.5	V
I <sub>REF(I)</sub>	Input current	SD16REFON = 0	3 V			50	nA

# MSP430F471x6, MSP430F471x7 MIXED SIGNAL MICROCONTROLLER

SLAS626A – OCTOBER 2008 – REVISED MAY 2009

electrical characteristics over recommended ranges of supply voltage and operating free-air temperature (unless otherwise noted) (continued)

## flash memory

PARAMETER		TEST CONDITIONS	V <sub>CC</sub>	MIN	TYP	MAX	UNIT
V <sub>CC(PGM/ERASE)</sub>	Program and erase supply voltage			2.2		3.6	V
f <sub>FTG</sub>	Flash timing generator frequency			257		476	kHz
I <sub>PGM</sub>	Supply current from V <sub>CC</sub> during program		2.2 V/3.6 V		3	5	mA
I <sub>ERASE</sub>	Supply current from V <sub>CC</sub> during erase		2.2 V/3.6 V		3	7	mA
t <sub>CPT</sub>	Cumulative program time (see Note 1)		2.2 V/3.6 V			10	ms
t <sub>CMErase</sub>	Cumulative mass erase time		2.2 V/3.6 V	20			ms
	Program/Erase endurance			10 <sup>4</sup>	10 <sup>5</sup>		cycles
t <sub>Retention</sub>	Data retention duration	T <sub>J</sub> = 25°C		100			years
t <sub>Word</sub>	Word or byte program time	see Note 2			30		t <sub>FTG</sub>
t <sub>Block, 0</sub>	Block program time for 1 <sup>st</sup> byte or word				25		t <sub>FTG</sub>
t <sub>Block, 1-63</sub>	Block program time for each additional byte or word				18		t <sub>FTG</sub>
t <sub>Block, End</sub>	Block program end-sequence wait time				6		t <sub>FTG</sub>
t <sub>Mass Erase</sub>	Mass erase time				10593		t <sub>FTG</sub>
t <sub>Seg Erase</sub>	Segment erase time				4819		t <sub>FTG</sub>
f <sub>MCLK,MGR</sub>	MCLK frequency in marginal read mode (FCTL4.MGR0 = 1 or FCTL4.MGR1 = 1)			0		1	MHz

- NOTES: 1. The cumulative program time must not be exceeded when writing to a 64-byte flash block. This parameter applies to all programming methods: individual word/byte write and block write modes.  
2. These values are hardwired into the Flash Controller's state machine (t<sub>FTG</sub> = 1/f<sub>FTG</sub>).

## RAM

PARAMETER	TEST CONDITIONS	MIN	MAX	UNIT
V <sub>(RAMh)</sub>	RAM retention supply voltage (see Note 1)	CPU halted	1.6	V

NOTE 1: This parameter defines the minimum supply voltage V<sub>CC</sub> when the data in RAM remains unchanged. No program execution should happen during this supply voltage condition.

## JTAG interface

PARAMETER	TEST CONDITIONS	V <sub>CC</sub>	MIN	TYP	MAX	UNIT	
f <sub>TCK</sub>	TCK input frequency	See Note 1	2.2 V	0	5	MHz	
			3 V	0	10	MHz	
R <sub>Internal</sub>	Internal pullup resistance on TMS, TCK, TDI/TCLK	See Note 2	2.2 V/ 3 V	25	40	90	kΩ

- NOTES: 1. f<sub>TCK</sub> may be restricted to meet the timing requirements of the module selected.  
2. TMS, TDI/TCLK, and TCK pull-up resistors are implemented in all versions.

## JTAG fuse (see Note 1)

PARAMETER	TEST CONDITIONS	V <sub>CC</sub>	MIN	NOM	MAX	UNIT
V <sub>CC(FB)</sub>	Supply voltage during fuse-blow condition	T <sub>A</sub> = 25°C	2.5			V
V <sub>FB</sub>	Voltage level on TDI/TCLK for fuse-blow: F versions		6		7	V
I <sub>FB</sub>	Supply current into TDI/TCLK during fuse blow				100	mA
t <sub>FB</sub>	Time to blow fuse				1	ms

NOTES: 1. Once the fuse is blown, no further access to the MSP430 JTAG/test and emulation features is possible. The JTAG block is switched to bypass mode.





APPLICATION INFORMATION

Port P1, P1.0 to P1.5, input/output with Schmitt trigger

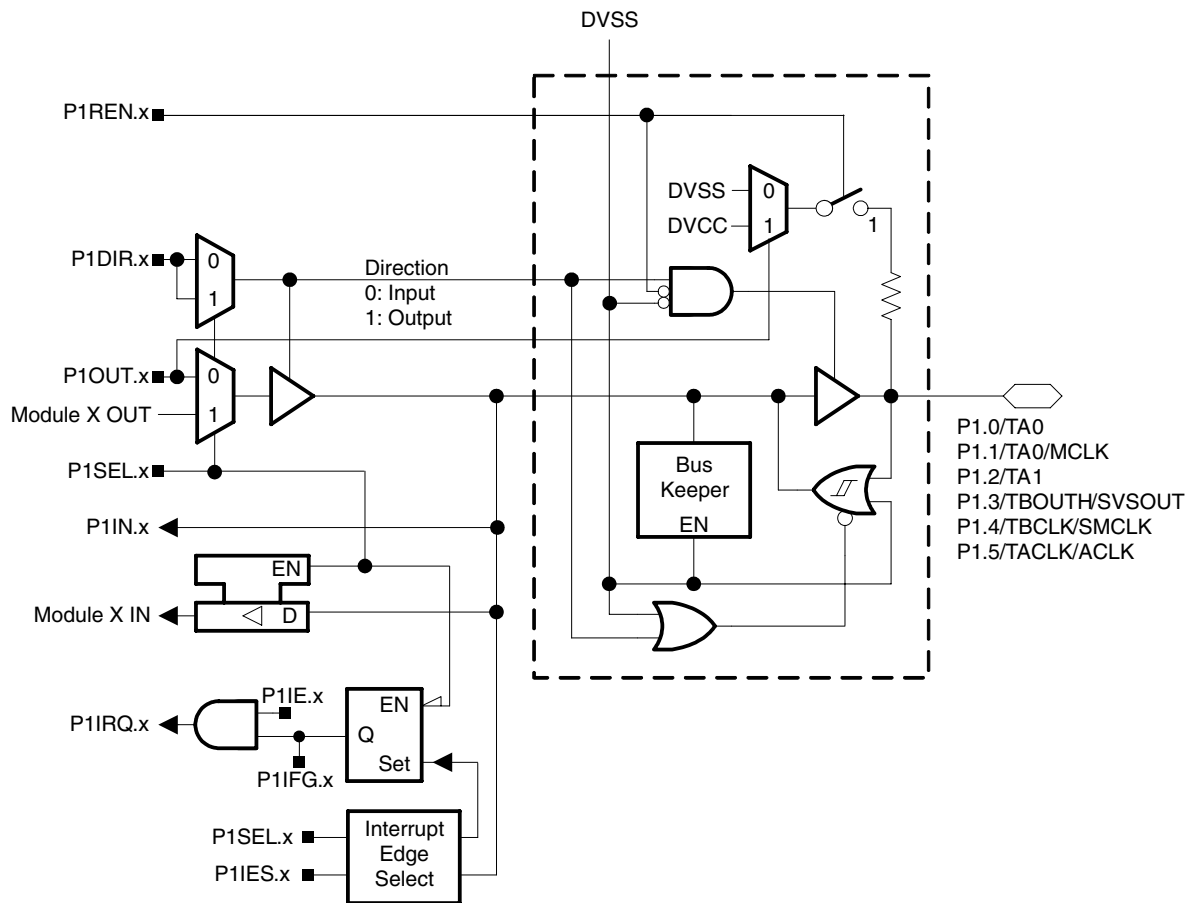

# MSP430F471x6, MSP430F471x7 MIXED SIGNAL MICROCONTROLLER

SLAS626A – OCTOBER 2008 – REVISED MAY 2009

## Port P1 (P1.0 to P1.5) pin functions

PIN NAME (P1.X)	X	FUNCTION	CONTROL BITS / SIGNALS	
			P1DIR.x	P1SEL.x
P1.0/TA0	0	P1.0 (I/O)	I: 0, O: 1	0
		Timer_A3.CCI0A	0	1
		Timer_A3.TA0	1	1
P1.1/TA0/MCLK	1	P1.1 (I/O)	I: 0, O: 1	0
		Timer_A3.CCI0B	0	1
		MCLK	1	1
P1.2/TA1	2	P1.2 (I/O)	I: 0, O: 1	0
		Timer_A3.CCI1A	0	1
		Timer_A3.TA1	1	1
P1.3/ TBOUTH/SVSOUT	3	P1.3 (I/O)	I: 0, O: 1	0
		Timer_B7.TBOUTH	0	1
		SVSOUT	1	1
P1.4/TBCLK/SMCLK	4	P1.4 (I/O)	I: 0, O: 1	0
		Timer_B7.TBCLK	0	1
		SMCLK	1	1
P1.5/TACLK/ACLK	5	P1.5 (I/O)	I: 0, O: 1	0
		Timer_A3.TACLK	0	1
		ACLK	1	1

NOTES: 1. X: Don't care

## Port P1, P1.6 and P1.7, input/output with Schmitt trigger

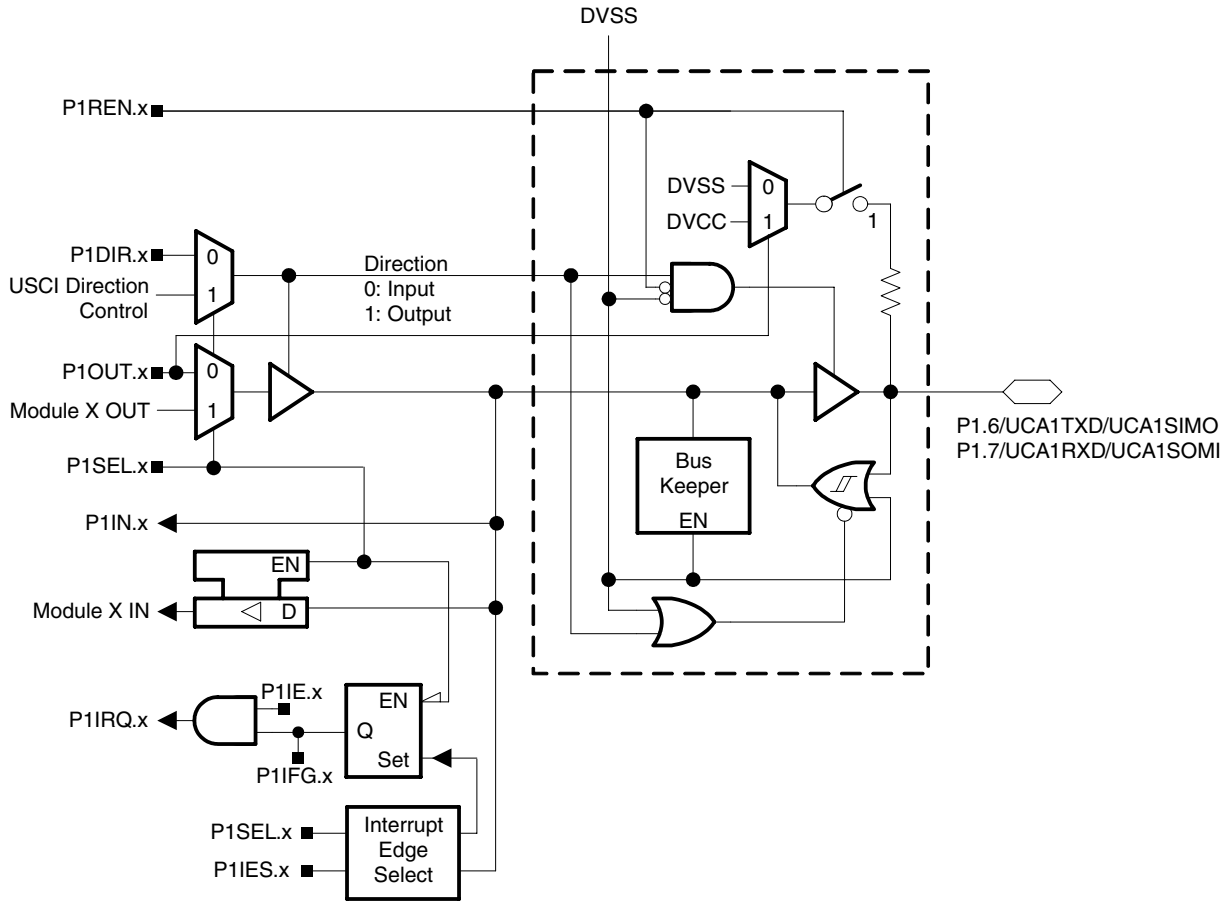

## Port P1 (P1.6 and P1.7) pin functions

PIN NAME (P1.X)	X	FUNCTION	CONTROL BITS / SIGNALS	
			P1DIR.x	P1SEL.x
P1.6/ UCA1TXD/UCA1SIMO	4	P1.6 (I/O)	I: 0, O: 1	0
		UCA1TXD/UCA1SIMO (see Note 1, 2)	X	1
P1.7/ UCA1RXD/UCA1SOMI	5	P1.7 (I/O)	I: 0, O: 1	0
		UCA1RXD/UCA1SOMI (see Note 1, 2)	X	1

NOTES: 1. X: Don't care  
2. The pin direction is controlled by the USC1 module.

# MSP430F471x6, MSP430F471x7 MIXED SIGNAL MICROCONTROLLER

SLAS626A – OCTOBER 2008 – REVISED MAY 2009

## Port P2, P2.0 to P2.5, input/output with Schmitt trigger

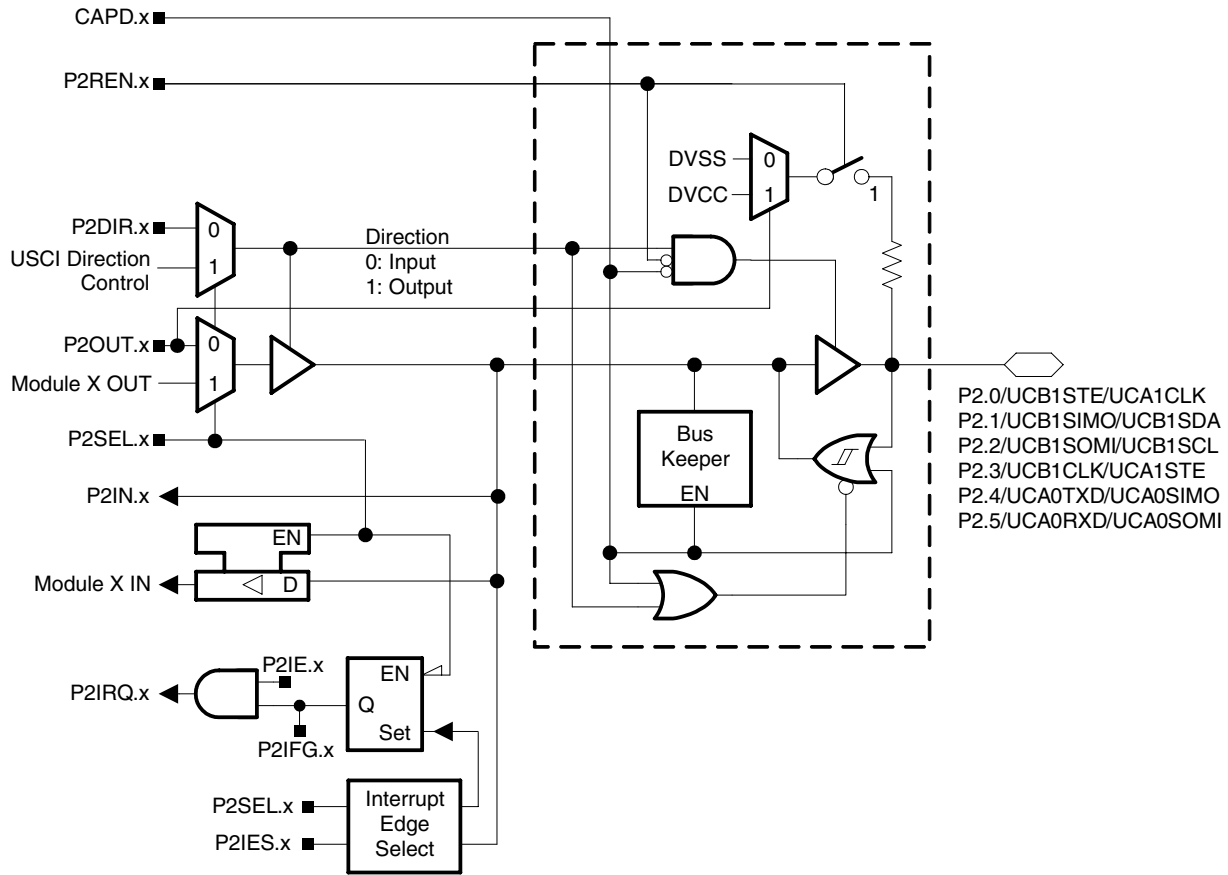

## Port P2 (P2.0 to P2.5) pin functions

PIN NAME (P2.X)	X	FUNCTION	CONTROL BITS / SIGNALS		
			P2DIR.x	P2SEL.x	CAPD.x
P2.0/ UCB1STE/UCA1CLK	4	P2.0 (I/O)	I: 0, O: 1	0	0
		UCB1STE/UCA1CLK (see Note 1, 2, 3)	X	1	0
		Input buffer disabled (see Note 6)	X	X	1
P2.1/ UCB1SIMO/UCB1SDA	4	P2.1 (I/O)	I: 0, O: 1	0	0
		UCB1SIMO/UCB1SDA (see Note 1, 2, 4)	X	1	0
		Input buffer disabled (see Note 6)	X	X	1
P2.2/ UCB1SOMI/UCB1SCL	4	P2.2 (I/O)	I: 0, O: 1	0	0
		UCB1SOMI/UCB1SCL (see Note 1, 2, 4)	X	1	0
		Input buffer disabled (see Note 6)	X	X	1
P2.3/ UCB1CLK/UCA1STE	4	P2.3 (I/O)	I: 0, O: 1	0	0
		UCB1CLK/UCA1STE (see Note 1, 2, 5)	X	1	0
		Input buffer disabled (see Note 6)	X	X	1
P2.4/ UCA0TXD/UCA0SIMO	4	P2.4 (I/O)	I: 0, O: 1	0	0
		UCA0TXD/UCA0SIMO (see Note 1, 2)	X	1	0
		Input buffer disabled (see Note 6)	X	X	1
P2.5/ UCA0RXD/UCA0SOMI	5	P2.5 (I/O)	I: 0, O: 1	0	0
		UCA0RXD/UCA0SOMI (see Note 1, 2)	X	1	0
		Input buffer disabled (see Note 6)	X	X	1

- NOTES:
1. X: Don't care
  2. The pin direction is controlled by the USCI module.
  3. UCA1CLK function takes precedence over UCB1STE function. If the pin is required as UCA1CLK input or output USCI\_B1 will be forced to 3-wire SPI mode even if 4-wire SPI mode is selected.
  4. In case the I2C functionality is selected the output drives only the logical 0 to  $V_{SS}$  level.
  5. UCB1CLK function takes precedence over UCA1STE function. If the pin is required as UCB1CLK input or output USCI\_A1 will be forced to 3-wire SPI mode even if 4-wire SPI mode is selected.
  6. Setting the CAPD.x bit disables the output driver as well as the input schmitt trigger to prevent parasitic cross currents when applying analog signals.

# MSP430F471x6, MSP430F471x7 MIXED SIGNAL MICROCONTROLLER

SLAS626A – OCTOBER 2008 – REVISED MAY 2009

## Port P2, P2.6 and P2.7, input/output with Schmitt trigger

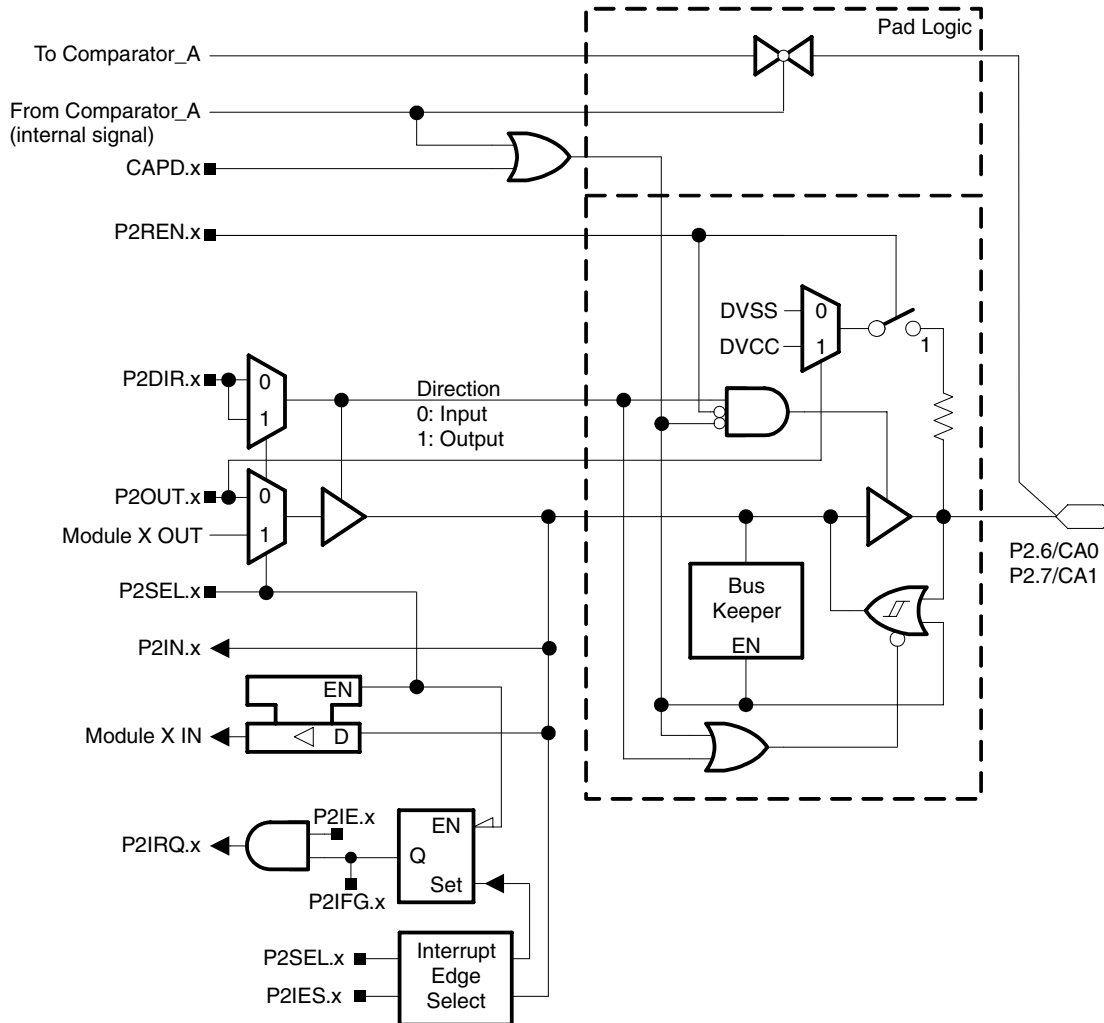

## Port P2 (P2.6 and P2.7) pin functions

PIN NAME (P2.X)	X	FUNCTION	CONTROL BITS / SIGNALS		
			P2DIR.x	P2SEL.x	CAPD.x
P2.6/CA0	6	P2.6 (I/O)	I: 0, O: 1	0	0
		N/A	0	1	0
		DVSS	1	1	0
		CA0 (see Note 3)	X	X	1
P2.7/CA1	7	P2.7 (I/O)	I: 0, O: 1	0	0
		N/A	0	1	0
		DVSS	1	1	0
		CA1 (see Note 3)	X	X	1

- NOTES: 1. X: Don't care  
 2. N/A: Not available or not applicable.  
 3. Setting the CAPD.x bit disables the output driver as well as the input schmitt trigger to prevent parasitic cross currents when applying analog signals.



POST OFFICE BOX 655303 • DALLAS, TEXAS 75265

## Port P3, P3.0 to P3.3, input/output with Schmitt trigger

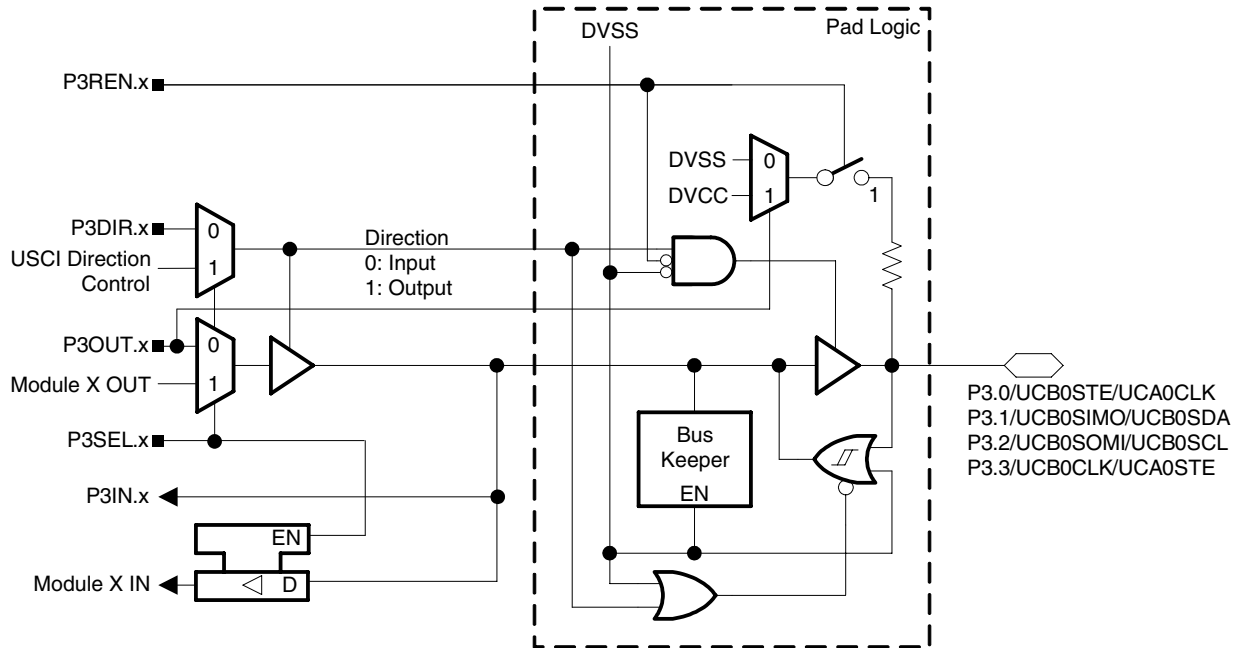

## Port P3 (P3.0 to P3.3) pin functions

PIN NAME (P3.X)	X	FUNCTION	CONTROL BITS / SIGNALS	
			P3DIR.x	P3SEL.x
P3.0/ UCA0CLK/UCB0STE	0	P3.0 (I/O)	I: 0, O: 1	0
		UCA0CLK/UCB0STE (see Notes 1, 2, 3)	X	1
P3.1/ UCB0SIMO/ UCB0SDA	1	P3.1 (I/O)	I: 0, O: 1	0
		UCB0SIMO/UCB0SDA (see Notes 1, 2, 4)	X	1
P3.2/ UCB0SOMI/ UCB0SCL	2	P3.2 (I/O)	I: 0, O: 1	0
		UCB0SOMI/UCB0SCL (see Notes 1, 2, 4)	X	1
P3.3/ UCB0CLK/UCA0STE	3	P3.3 (I/O)	I: 0, O: 1	0
		UCB0CLK/UCA0STE (see Notes 1, 2, 5)	X	1

- NOTES:
1. X: Don't care
  2. The pin direction is controlled by the USCI module.
  3. UCA0CLK function takes precedence over UCB0STE function. If the pin is required as UCA0CLK input or output USCI\_B0 will be forced to 3-wire SPI mode even if 4-wire SPI mode is selected.
  4. In case the I2C functionality is selected the output drives only the logical 0 to  $V_{SS}$  level.
  5. UCB0CLK function takes precedence over UCA0STE function. If the pin is required as UCB0CLK input or output USCI\_A0 will be forced to 3-wire SPI mode even if 4-wire SPI mode is selected.

# MSP430F471x6, MSP430F471x7 MIXED SIGNAL MICROCONTROLLER

SLAS626A – OCTOBER 2008 – REVISED MAY 2009

## Port P3, P3.4, input/output with Schmitt trigger

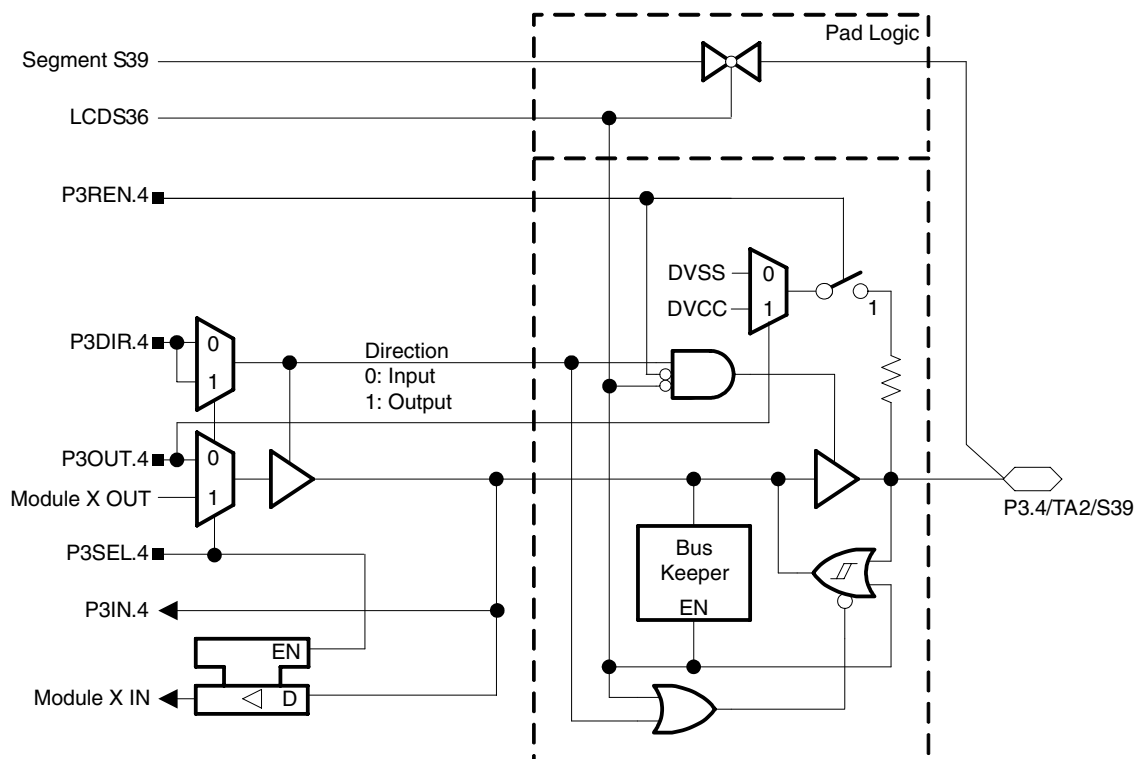

## Port P3 (P3.4) pin functions

PIN NAME (P3.X)	X	FUNCTION	CONTROL BITS / SIGNALS		
			P3DIR.x	P3SEL.x	LCDS36
P3.4/TA2/S39	4	P3.4 (I/O)	I: 0, O: 1	0	0
		Timer_A3.CCI2A	0	1	0
		Timer_A3.TA2	1	1	0
		S39	X	X	1

NOTES: 1. X: Don't care



## Port P3, P3.5 to P3.7, input/output with Schmitt trigger

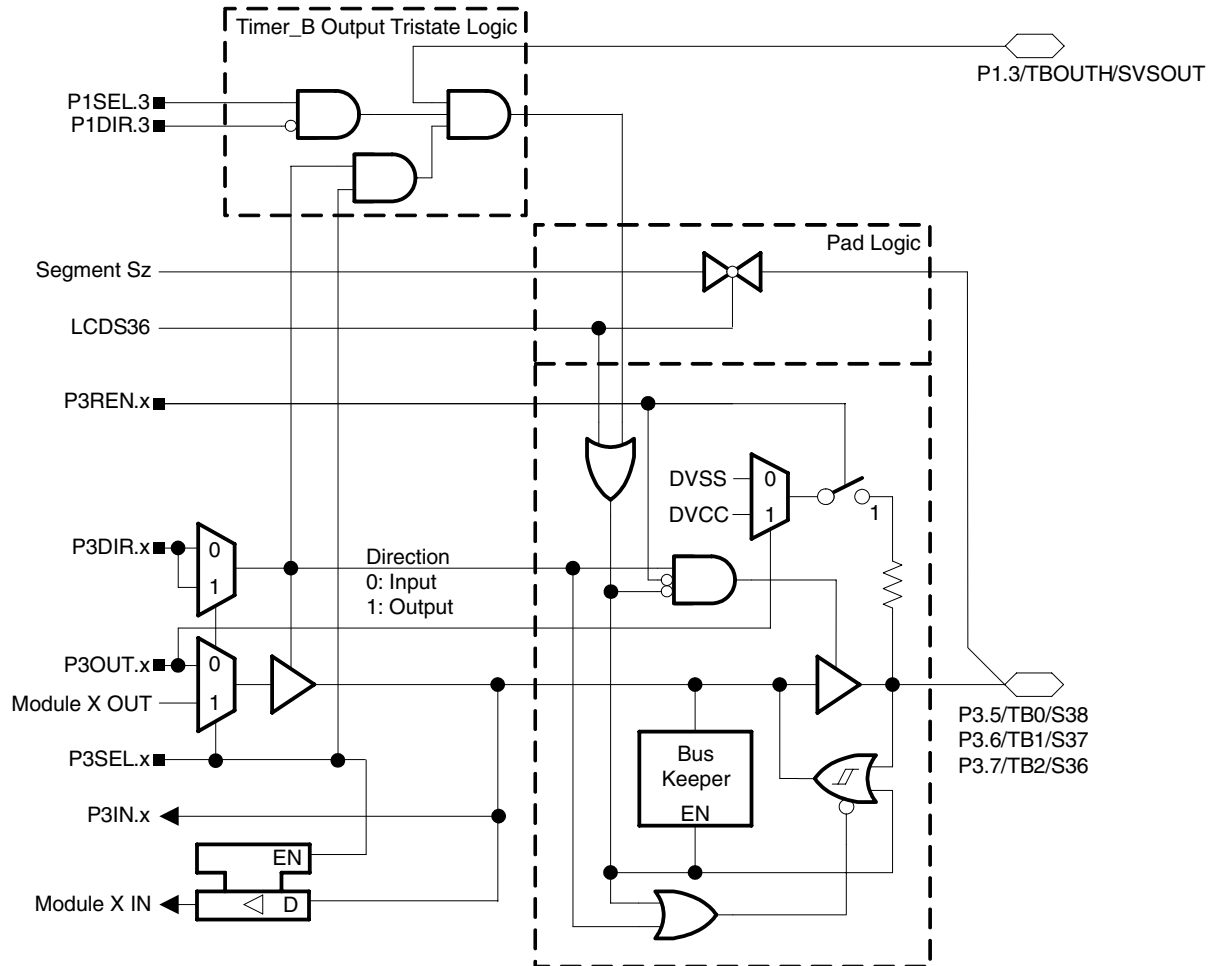

## Port P3 (P3.5 to P3.7) pin functions

PIN NAME (P3.X)	X	FUNCTION	CONTROL BITS / SIGNALS		
			P3DIR.x	P3SEL.x	LCDS36
P3.5/TB0/S38	5	P3.5 (I/O)	I: 0, O: 1	0	0
		Timer_B3.CCI0A and Timer_B3.CCI0B	0	1	0
		Timer_B3.TB0 (see Note 2)	1	1	0
		S38	X	X	1
P3.6/TB1/S37	6	P3.6 (I/O)	I: 0, O: 1	0	0
		Timer_B3.CCI1A and Timer_B3.CCI1B	0	1	0
		Timer_B3.TB1 (see Note 2)	1	1	0
		S37	X	X	1
P3.7/TB2/S36	7	P3.7 (I/O)	I: 0, O: 1	0	0
		Timer_B3.CCI2A and Timer_B3.CCI2B	0	1	0
		Timer_B3.TB3 (see Note 2)	1	1	0
		S36	X	X	1

NOTES: 1. X: Don't care  
2. Setting TBOUTH causes all Timer\_B outputs to be set to high impedance.

# MSP430F471x6, MSP430F471x7 MIXED SIGNAL MICROCONTROLLER

SLAS626A – OCTOBER 2008 – REVISED MAY 2009

## Port P4, P4.0 and P4.1, input/output with Schmitt trigger

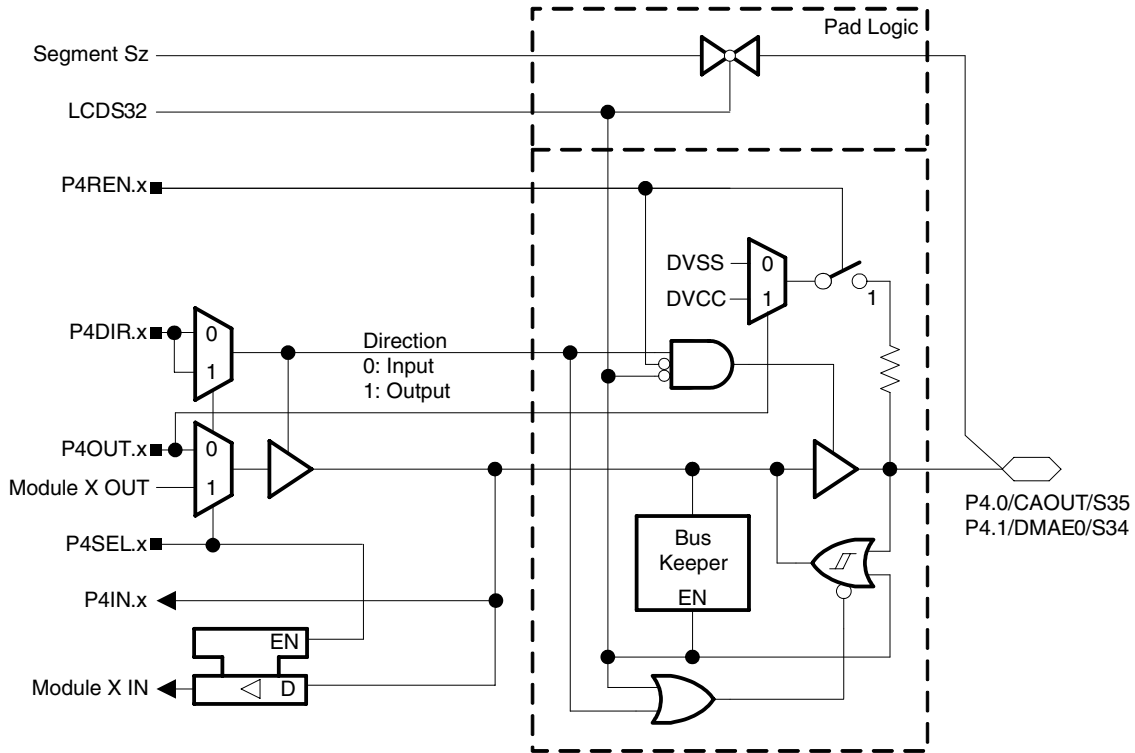

## Port P4 (P4.0 and P4.1) pin functions

PIN NAME (P4.X)	X	FUNCTION	CONTROL BITS / SIGNALS		
			P4DIR.x	P4SEL.x	LCDS32
P4.0/CAOUT/S35	0	P4.0 (I/O)	I: 0, O: 1	0	0
		N/A	0	1	0
		CAOUT	1	1	0
		S35	X	X	1
P4.1/DMAE0/S34	1	P4.1 (I/O)	I: 0, O: 1	0	0
		DMAE0	0	1	0
		DVSS	1	1	0
		S34	X	X	1

NOTES: 1. X: Don't care  
2. N/A: Not available or not applicable.

## Port P4, P4.2 to P4.7, input/output with Schmitt trigger

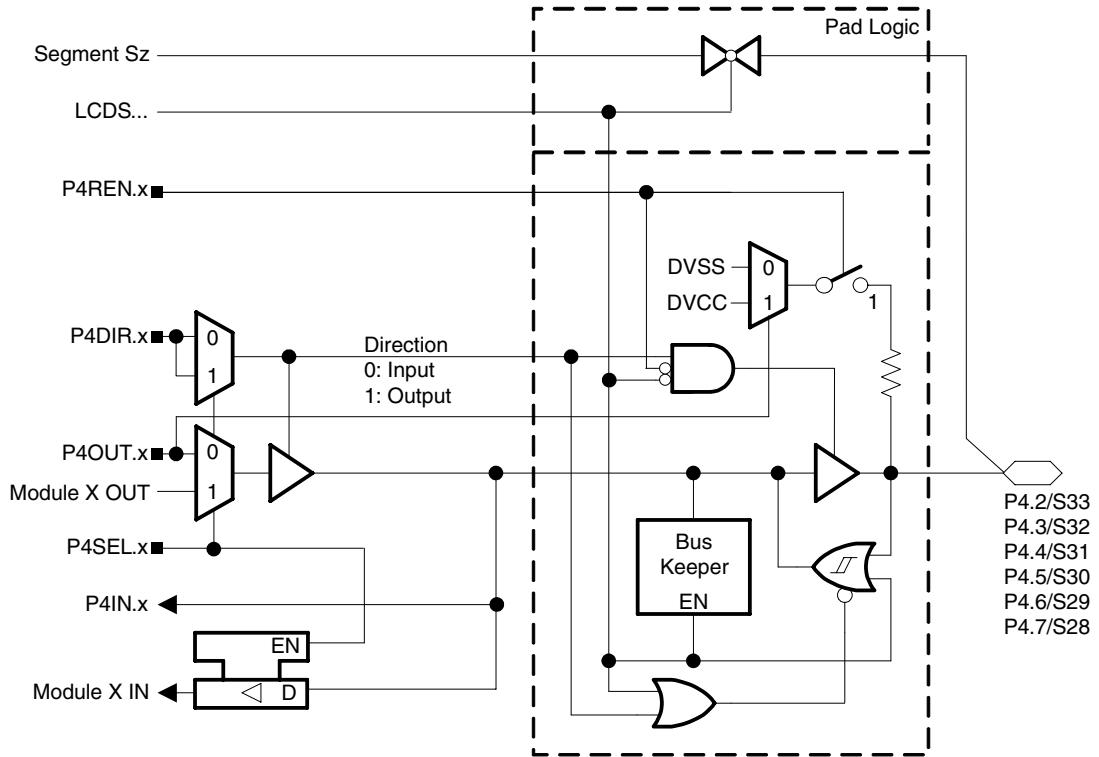

# MSP430F471x6, MSP430F471x7 MIXED SIGNAL MICROCONTROLLER

SLAS626A – OCTOBER 2008 – REVISED MAY 2009

## Port P4 (P4.2 and P4.3) pin functions

PIN NAME (P4.X)	X	FUNCTION	CONTROL BITS / SIGNALS		
			P4DIR.x	P4SEL.x	LCDS32
P4.2/S33	2	P4.2 (I/O)	I: 0, O: 1	0	0
		N/A	0	1	0
		DVSS	1	1	0
		S33	X	X	1
P4.3/S32	3	P4.3 (I/O)	I: 0, O: 1	0	0
		N/A	0	1	0
		DVSS	1	1	0
		S32	X	X	1

NOTES: 1. X: Don't care  
2. N/A: Not available or not applicable.

## Port P4 (P4.4 to P4.7) pin functions

PIN NAME (P4.X)	X	FUNCTION	CONTROL BITS / SIGNALS		
			P4DIR.x	P4SEL.x	LCDS28
P4.4/S31	4	P4.4 (I/O)	I: 0, O: 1	0	0
		N/A	0	1	0
		DVSS	1	1	0
		S31	X	X	1
P4.5/S30	5	P4.5 (I/O)	I: 0, O: 1	0	0
		N/A	0	1	0
		DVSS	1	1	0
		S30	X	X	1
P4.6/S29	5	P4.6 (I/O)	I: 0, O: 1	0	0
		N/A	0	1	0
		DVSS	1	1	0
		S29	X	X	1
P4.7/S28	5	P4.7 (I/O)	I: 0, O: 1	0	0
		N/A	0	1	0
		DVSS	1	1	0
		S28	X	X	1

NOTES: 1. X: Don't care  
2. N/A: Not available or not applicable.



Port P5, P5.0, input/output with Schmitt trigger

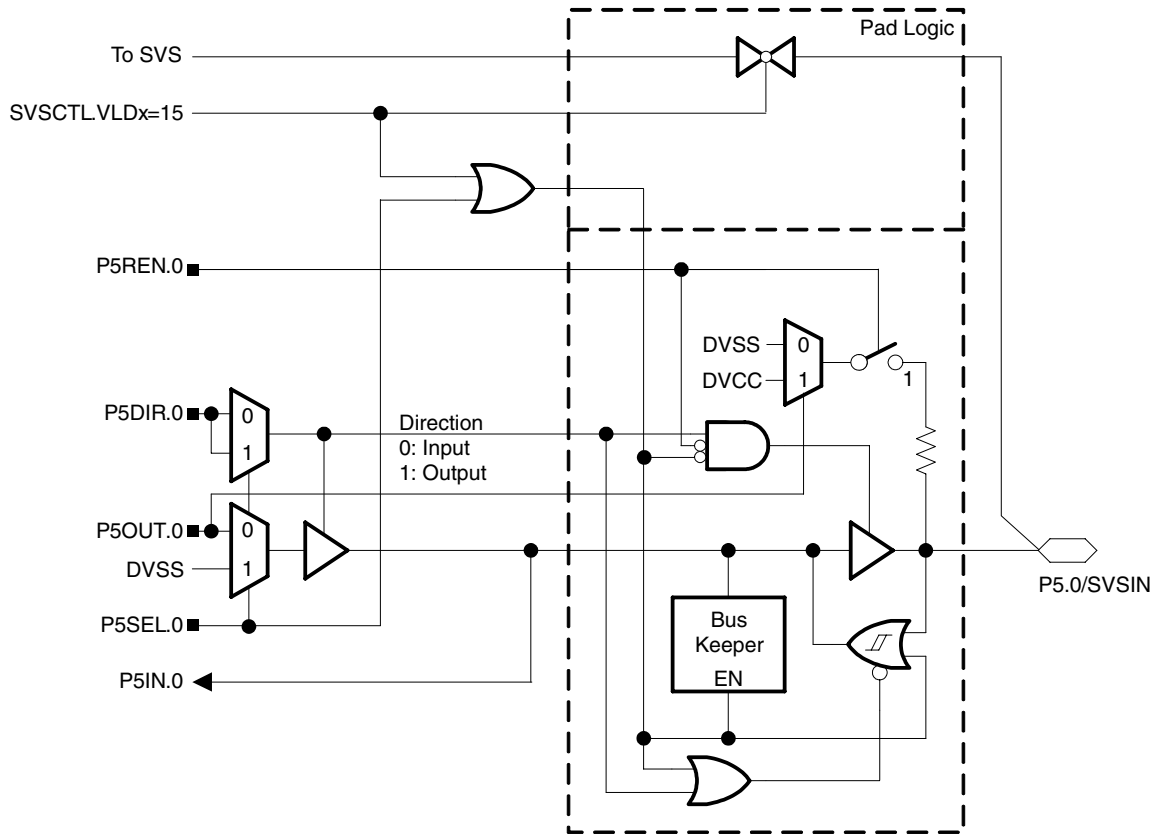

Port P5 (P5.0) pin functions

PIN NAME (P5.X)	X	FUNCTION	CONTROL BITS / SIGNALS	
			P5DIR.x	P5SEL.x
P5.0/SVSIN	0	P5.0 (I/O) (see Note 1)	I: 0, O: 1	0
		SVSIN (see Notes 1 and 3)	X	1

- NOTES: 1. X: Don't care  
 2. N/A: Not available or not applicable.  
 3. Setting the P5SEL.x bit disables the output driver as well as the input Schmitt trigger to prevent parasitic cross currents when applying analog signals. To enable the SVSIN function the SVS input also needs to be selected in the SVS module by setting the VLDx bits to 15.

# MSP430F471x6, MSP430F471x7 MIXED SIGNAL MICROCONTROLLER

SLAS626A – OCTOBER 2008 – REVISED MAY 2009

## Port P5, P5.1 to P5.7, input/output with Schmitt trigger

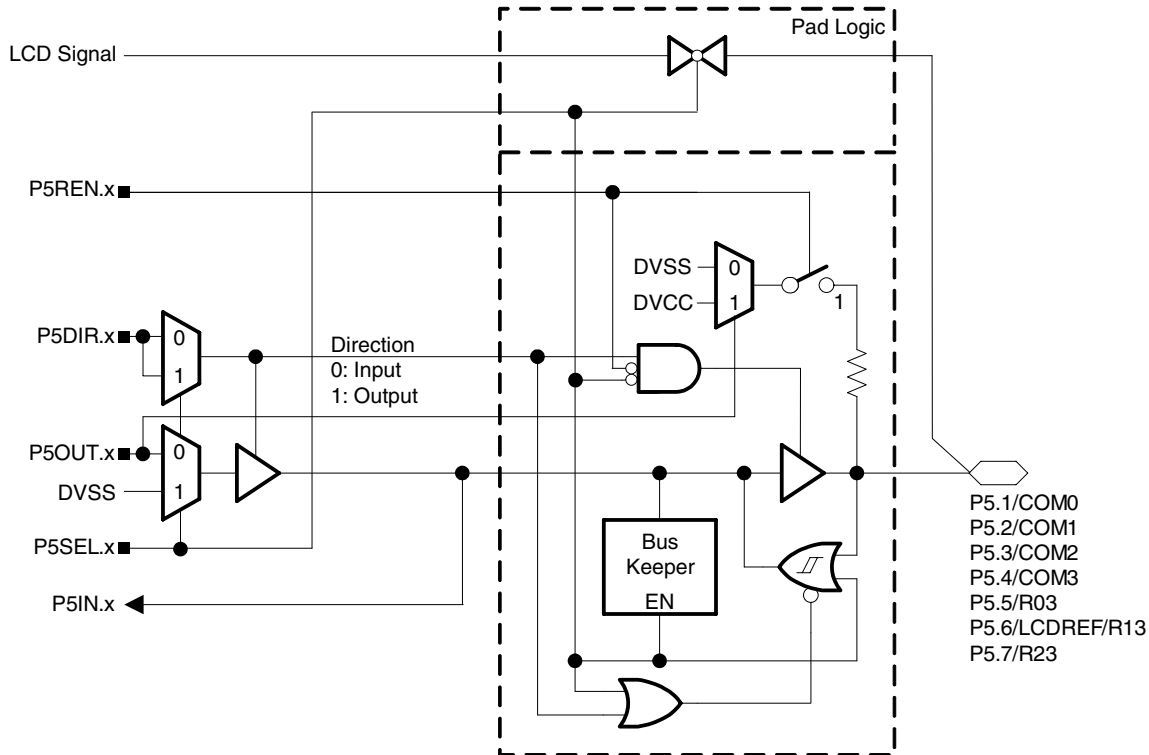

## Port P5 (P5.1 to P5.7) pin functions

PIN NAME (P5.X)	X	FUNCTION	CONTROL BITS / SIGNALS	
			P5DIR.x	P5SEL.x
P5.1/COM0	2	P5.2 (I/O)	I: 0, O: 1	0
		COM0 (see Note 2)	X	1
P5.2/COM1	2	P5.2 (I/O)	I: 0, O: 1	0
		COM1 (see Note 2)	X	1
P5.3/COM2	3	P5.3 (I/O)	I: 0, O: 1	0
		COM2 (see Note 2)	X	1
P5.4/COM3	4	P5.4 (I/O)	I: 0, O: 1	0
		COM3 (see Note 2)	X	1
P5.5/R03	5	P5.5 (I/O)	I: 0, O: 1	0
		R03 (see Note 2)	X	1
P5.6/LCDREF/R13	6	P5.6 (I/O)	I: 0, O: 1	0
		R13 or LCDREF (see Notes 2 and 3)	X	1
P5.7/R23	7	P5.7 (I/O)	I: 0, O: 1	0
		R23 (see Note 2)	X	1

NOTES: 1. X: Don't care

2. Setting the P5SEL.x bit disables the output driver as well as the input Schmitt trigger to prevent parasitic cross currents when applying analog signals.

3. External reference for the LCD\_A charge pump is applied when VLCDREFx = 01. Otherwise R13 is selected.



POST OFFICE BOX 655303 • DALLAS, TEXAS 75265

Port P7 to port P10, input/output with Schmitt trigger

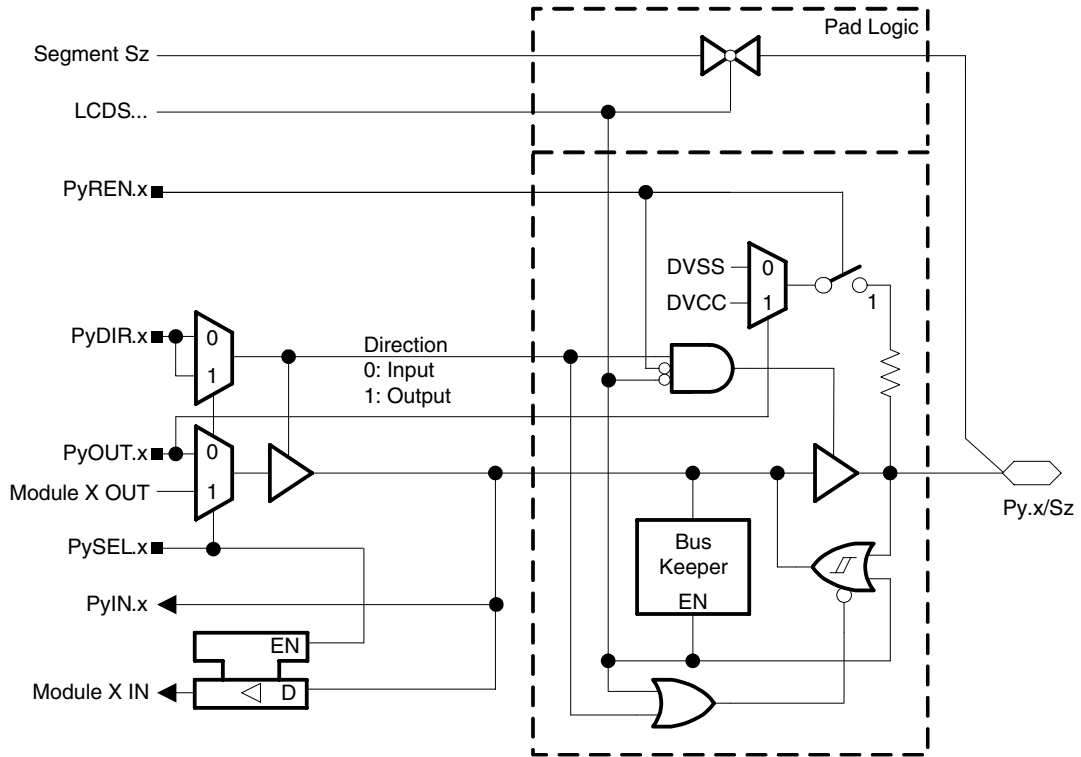

# MSP430F471x6, MSP430F471x7 MIXED SIGNAL MICROCONTROLLER

SLAS626A – OCTOBER 2008 – REVISED MAY 2009

## Port P7 (P7.0 to P7.3) pin functions

PIN NAME (P7.X)	X	FUNCTION	CONTROL BITS / SIGNALS		
			P7DIR.x	P7SEL.x	LCDS24
P7.0/S27	0	P7.0 (I/O)	I: 0, O: 1	0	0
		N/A	0	1	0
		DVSS	1	1	0
		S27	X	X	1
P7.1/S26	1	P7.1 (I/O)	I: 0, O: 1	0	0
		N/A	0	1	0
		DVSS	1	1	0
		S26	X	X	1
P7.2/S25	2	P7.2 (I/O)	I: 0, O: 1	0	0
		N/A	0	1	0
		DVSS	1	1	0
		S25	X	X	1
P7.3/S24	3	P7.3 (I/O)	I: 0, O: 1	0	0
		N/A	0	1	0
		DVSS	1	1	0
		S24	X	X	1

NOTES: 1. X: Don't care  
2. N/A: Not available or not applicable.

## Port P7 (P7.4 to P7.7) pin functions

PIN NAME (P7.X)	X	FUNCTION	CONTROL BITS / SIGNALS		
			P7DIR.x	P7SEL.x	LCDS20
P7.4/S23	4	P7.4 (I/O)	I: 0, O: 1	0	0
		N/A	0	1	0
		DVSS	1	1	0
		S23	X	X	1
P7.5/S22	5	P7.5 (I/O)	I: 0, O: 1	0	0
		N/A	0	1	0
		DVSS	1	1	0
		S22	X	X	1
P7.6/S21	6	P7.6 (I/O)	I: 0, O: 1	0	0
		N/A	0	1	0
		DVSS	1	1	0
		S21	X	X	1
P7.7/S20	7	P7.7 (I/O)	I: 0, O: 1	0	0
		N/A	0	1	0
		DVSS	1	1	0
		S20	X	X	1

NOTES: 1. X: Don't care  
2. N/A: Not available or not applicable.





# MSP430F471x6, MSP430F471x7 MIXED SIGNAL MICROCONTROLLER

SLAS626A – OCTOBER 2008 – REVISED MAY 2009

## Port P8 (P8.0 to P8.3) pin functions

PIN NAME (P8.X)	X	FUNCTION	CONTROL BITS / SIGNALS		
			P8DIR.x	P8SEL.x	LCDS16
P8.0/S19	0	P8.0 (I/O)	I: 0, O: 1	0	0
		N/A	0	1	0
		DVSS	1	1	0
		S19	X	X	1
P8.1/S18	1	P8.0 (I/O)	I: 0, O: 1	0	0
		N/A	0	1	0
		DVSS	1	1	0
		S18	X	X	1
P8.2/S17	2	P8.2 (I/O)	I: 0, O: 1	0	0
		N/A	0	1	0
		DVSS	1	1	0
		S17	X	X	1
P8.3/S16	3	P8.3 (I/O)	I: 0, O: 1	0	0
		N/A	0	1	0
		DVSS	1	1	0
		S16	X	X	1

NOTES: 1. X: Don't care  
2. N/A: Not available or not applicable.

## Port P8 (P8.4 to P8.7) pin functions

PIN NAME (P8.X)	X	FUNCTION	CONTROL BITS / SIGNALS		
			P8DIR.x	P8SEL.x	LCDS12
P8.4/S15	4	P8.4 (I/O)	I: 0, O: 1	0	0
		N/A	0	1	0
		DVSS	1	1	0
		S15	X	X	1
P8.5/S14	5	P8.5 (I/O)	I: 0, O: 1	0	0
		N/A	0	1	0
		DVSS	1	1	0
		S14	X	X	1
P8.6/S13	6	P8.6 (I/O)	I: 0, O: 1	0	0
		N/A	0	1	0
		DVSS	1	1	0
		S13	X	X	1
P8.7/S12	7	P8.7 (I/O)	I: 0, O: 1	0	0
		N/A	0	1	0
		DVSS	1	1	0
		S12	X	X	1

NOTES: 1. X: Don't care  
2. N/A: Not available or not applicable.



# MSP430F471x6, MSP430F471x7 MIXED SIGNAL MICROCONTROLLER

SLAS626A – OCTOBER 2008 – REVISED MAY 2009

## Port P9 (P9.0 to P9.3) pin functions

PIN NAME (P9.X)	X	FUNCTION	CONTROL BITS / SIGNALS		
			P9DIR.x	P9SEL.x	LCDS8
P9.0/S11	0	P9.0 (I/O)	I: 0, O: 1	0	0
		N/A	0	1	0
		DVSS	1	1	0
		S11	X	X	1
P9.1/S10	1	P9.1 (I/O)	I: 0, O: 1	0	0
		N/A	0	1	0
		DVSS	1	1	0
		S10	X	X	1
P9.2/S9	2	P9.2 (I/O)	I: 0, O: 1	0	0
		N/A	0	1	0
		DVSS	1	1	0
		S9	X	X	1
P9.3/S8	3	P9.3 (I/O)	I: 0, O: 1	0	0
		N/A	0	1	0
		DVSS	1	1	0
		S8	X	X	1

NOTES: 1. X: Don't care  
2. N/A: Not available or not applicable.

## Port P9 (P9.4 to P9.7) pin functions

PIN NAME (P9.X)	X	FUNCTION	CONTROL BITS / SIGNALS		
			P9DIR.x	P9SEL.x	LCDS4
P9.4/S7	4	P9.4 (I/O)	I: 0, O: 1	0	0
		N/A	0	1	0
		DVSS	1	1	0
		S7	X	X	1
P9.5/S6	5	P9.5 (I/O)	I: 0, O: 1	0	0
		N/A	0	1	0
		DVSS	1	1	0
		S6	X	X	1
P9.6/S5	6	P9.6 (I/O)	I: 0, O: 1	0	0
		N/A	0	1	0
		DVSS	1	1	0
		S5	X	X	1
P9.7/S4	7	P9.7 (I/O)	I: 0, O: 1	0	0
		N/A	0	1	0
		DVSS	1	1	0
		S4	X	X	1

NOTES: 1. X: Don't care  
2. N/A: Not available or not applicable.



# MSP430F471x6, MSP430F471x7 MIXED SIGNAL MICROCONTROLLER

SLAS626A – OCTOBER 2008 – REVISED MAY 2009

## Port P10 (P10.0 to P10.3) pin functions

PIN NAME (P10.X)	X	FUNCTION	CONTROL BITS / SIGNALS		
			P10DIR.x	P10SEL.x	LCDS0
P10.0/S3	0	P10.0 (I/O)	I: 0, O: 1	0	0
		N/A	0	1	0
		DVSS	1	1	0
		S3	X	X	1
P10.1/S2	1	P10.1 (I/O)	I: 0, O: 1	0	0
		N/A	0	1	0
		DVSS	1	1	0
		S2	X	X	1
P10.2/S1	2	P10.2 (I/O)	I: 0, O: 1	0	0
		N/A	0	1	0
		DVSS	1	1	0
		S1	X	X	1
P10.3/S0	3	P10.3 (I/O)	I: 0, O: 1	0	0
		N/A	0	1	0
		DVSS	1	1	0
		S0	X	X	1

NOTES: 1. X: Don't care  
2. N/A: Not available or not applicable.



## JTAG fuse check mode

MSP430 devices that have the fuse on the TDI/TCLK terminal have a fuse check mode that tests the continuity of the fuse the first time the JTAG port is accessed after a power-on reset (POR). When activated, a fuse check current ( $I_{(TF)}$ ) of 1 mA at 3 V can flow from the TDI/TCLK pin to ground if the fuse is not burned. Care must be taken to avoid accidentally activating the fuse check mode and increasing overall system power consumption.

Activation of the fuse check mode occurs with the first negative edge on the TMS pin after power up or if the TMS is being held low during power up. The second positive edge on the TMS pin deactivates the fuse check mode. After deactivation, the fuse check mode remains inactive until another POR occurs. After each POR the fuse check mode has the potential to be activated.

The fuse check current only flows when the fuse check mode is active and the TMS pin is in a low state (see Figure 27). Therefore, the additional current flow can be prevented by holding the TMS pin high (default condition). The JTAG pins are terminated internally and therefore do not require external termination.

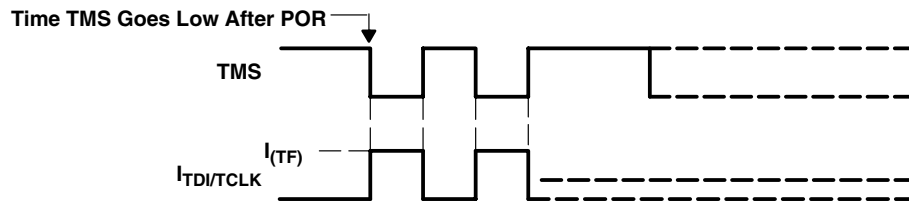

Figure 27. Fuse Check Mode Current MSP430F471x7

# MSP430F471x6, MSP430F471x7 MIXED SIGNAL MICROCONTROLLER

SLAS626A – OCTOBER 2008 – REVISED MAY 2009

---

## Data Sheet Revision History

LITERATURE NUMBER	SUMMARY
SLAS626	Product Preview release
SLAS626A	Production Data release

NOTE: Page and figure numbers refer to the respective document revision and may differ in other revisions.



**PACKAGING INFORMATION**

Orderable Device	Status <sup>(1)</sup>	Package Type	Package Drawing	Pins	Package Qty	Eco Plan <sup>(2)</sup>	Lead/Ball Finish	MSL Peak Temp <sup>(3)</sup>
MSP430F47166IPZ	ACTIVE	LQFP	PZ	100	50	Green (RoHS & no Sb/Br)	NIPDAU	Level-3-260C-168 HR
MSP430F47166IPZR	ACTIVE	LQFP	PZ	100	1000	Green (RoHS & no Sb/Br)	NIPDAU	Level-3-260C-168 HR
MSP430F47167IPZ	ACTIVE	LQFP	PZ	100	50	Green (RoHS & no Sb/Br)	NIPDAU	Level-3-260C-168 HR
MSP430F47167IPZR	ACTIVE	LQFP	PZ	100	1000	Green (RoHS & no Sb/Br)	NIPDAU	Level-3-260C-168 HR
MSP430F47176IPZ	ACTIVE	LQFP	PZ	100	50	Green (RoHS & no Sb/Br)	NIPDAU	Level-3-260C-168 HR
MSP430F47176IPZR	ACTIVE	LQFP	PZ	100	1000	Green (RoHS & no Sb/Br)	NIPDAU	Level-3-260C-168 HR
MSP430F47177IPZ	ACTIVE	LQFP	PZ	100	50	Green (RoHS & no Sb/Br)	NIPDAU	Level-3-260C-168 HR
MSP430F47177IPZR	ACTIVE	LQFP	PZ	100	1000	Green (RoHS & no Sb/Br)	NIPDAU	Level-3-260C-168 HR
MSP430F47186IPZ	ACTIVE	LQFP	PZ	100	50	Green (RoHS & no Sb/Br)	NIPDAU	Level-3-260C-168 HR
MSP430F47186IPZR	ACTIVE	LQFP	PZ	100	1000	Green (RoHS & no Sb/Br)	NIPDAU	Level-3-260C-168 HR
MSP430F47187IPZ	ACTIVE	LQFP	PZ	100	50	Green (RoHS & no Sb/Br)	NIPDAU	Level-3-260C-168 HR
MSP430F47187IPZR	ACTIVE	LQFP	PZ	100	1000	Green (RoHS & no Sb/Br)	NIPDAU	Level-3-260C-168 HR
MSP430F47196IPZ	ACTIVE	LQFP	PZ	100	50	Green (RoHS & no Sb/Br)	NIPDAU	Level-3-260C-168 HR
MSP430F47196IPZR	ACTIVE	LQFP	PZ	100	1000	Green (RoHS & no Sb/Br)	NIPDAU	Level-3-260C-168 HR
MSP430F47197IPZ	ACTIVE	LQFP	PZ	100	50	Green (RoHS & no Sb/Br)	NIPDAU	Level-3-260C-168 HR
MSP430F47197IPZR	ACTIVE	LQFP	PZ	100	1000	Green (RoHS & no Sb/Br)	NIPDAU	Level-3-260C-168 HR

<sup>(1)</sup> The marketing status values are defined as follows:

**ACTIVE:** Product device recommended for new designs.

**LIFEBUY:** TI has announced that the device will be discontinued, and a lifetime-buy period is in effect.

**NRND:** Not recommended for new designs. Device is in production to support existing customers, but TI does not recommend using this part in a new design.

**PREVIEW:** Device has been announced but is not in production. Samples may or may not be available.

**OBsolete:** TI has discontinued the production of the device.

<sup>(2)</sup> Eco Plan - The planned eco-friendly classification: Pb-Free (RoHS), Pb-Free (RoHS Exempt), or Green (RoHS & no Sb/Br) - please check <http://www.ti.com/productcontent> for the latest availability information and additional product content details.

**TBD:** The Pb-Free/Green conversion plan has not been defined.

**Pb-Free (RoHS):** TI's terms "Lead-Free" or "Pb-Free" mean semiconductor products that are compatible with the current RoHS requirements for all 6 substances, including the requirement that lead not exceed 0.1% by weight in homogeneous materials. Where designed to be soldered at high temperatures, TI Pb-Free products are suitable for use in specified lead-free processes.

**Pb-Free (RoHS Exempt):** This component has a RoHS exemption for either 1) lead-based flip-chip solder bumps used between the die and package, or 2) lead-based die adhesive used between the die and leadframe. The component is otherwise considered Pb-Free (RoHS compatible) as defined above.

**Green (RoHS & no Sb/Br):** TI defines "Green" to mean Pb-Free (RoHS compatible), and free of Bromine (Br) and Antimony (Sb) based flame retardants (Br or Sb do not exceed 0.1% by weight in homogeneous material)

<sup>(3)</sup> MSL, Peak Temp. -- The Moisture Sensitivity Level rating according to the JEDEC industry standard classifications, and peak solder temperature.

**Important Information and Disclaimer:**The information provided on this page represents TI's knowledge and belief as of the date that it is provided. TI bases its knowledge and belief on information provided by third parties, and makes no representation or warranty as to the accuracy of such information. Efforts are underway to better integrate information from third parties. TI has taken and continues to take reasonable steps to provide representative and accurate information but may not have conducted destructive testing or chemical analysis on incoming materials and chemicals. TI and TI suppliers consider certain information to be proprietary, and thus CAS numbers and other limited information may not be available for release.

In no event shall TI's liability arising out of such information exceed the total purchase price of the TI part(s) at issue in this document sold by TI to Customer on an annual basis.



PZ (S-PQFP-G100)

PLASTIC QUAD FLATPACK

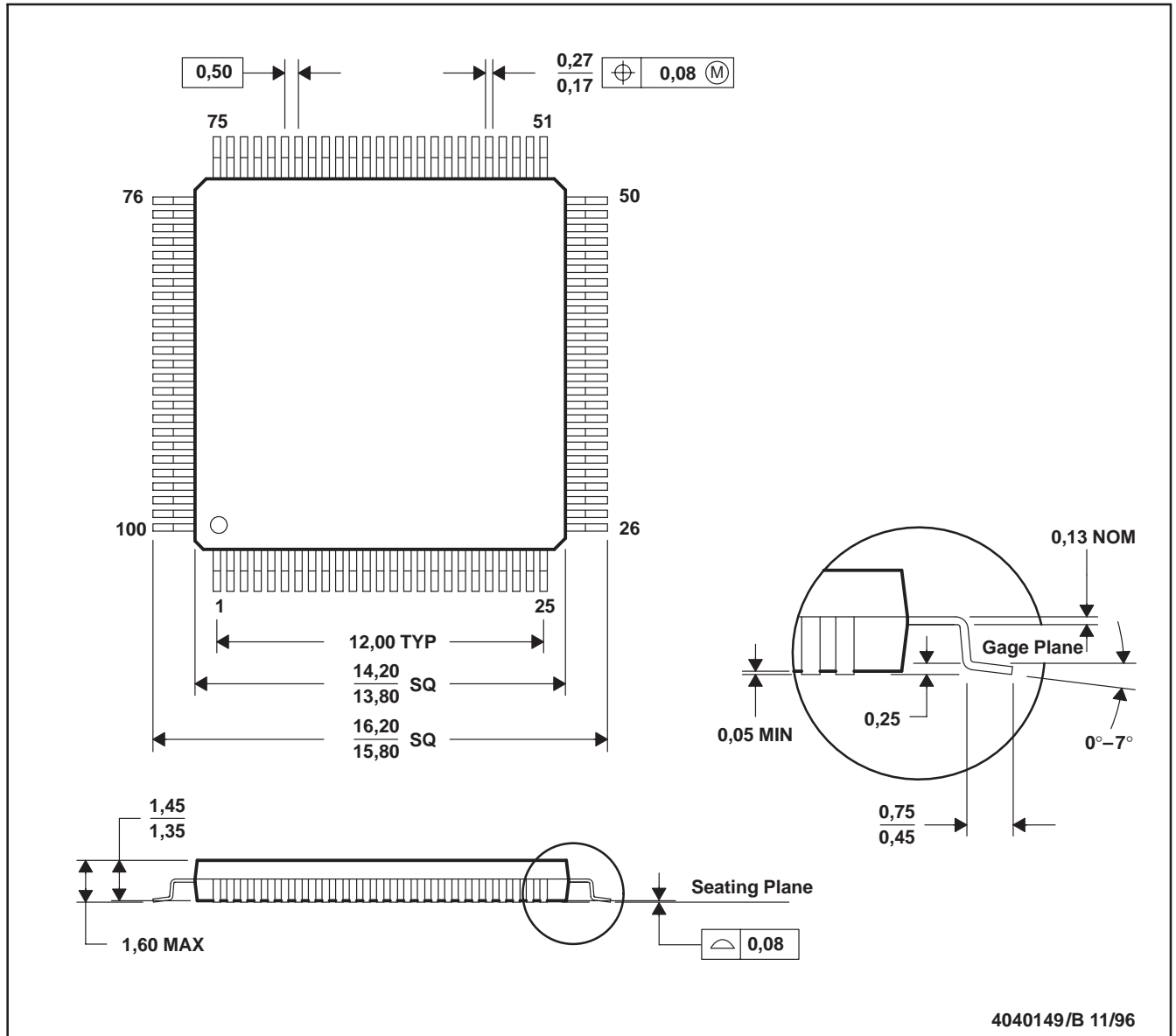

4040149/B 11/96

- NOTES: A. All linear dimensions are in millimeters.  
 B. This drawing is subject to change without notice.  
 C. Falls within JEDEC MS-026

## IMPORTANT NOTICE

Texas Instruments Incorporated and its subsidiaries (TI) reserve the right to make corrections, modifications, enhancements, improvements, and other changes to its products and services at any time and to discontinue any product or service without notice. Customers should obtain the latest relevant information before placing orders and should verify that such information is current and complete. All products are sold subject to TI's terms and conditions of sale supplied at the time of order acknowledgment.

TI warrants performance of its hardware products to the specifications applicable at the time of sale in accordance with TI's standard warranty. Testing and other quality control techniques are used to the extent TI deems necessary to support this warranty. Except where mandated by government requirements, testing of all parameters of each product is not necessarily performed.

TI assumes no liability for applications assistance or customer product design. Customers are responsible for their products and applications using TI components. To minimize the risks associated with customer products and applications, customers should provide adequate design and operating safeguards.

TI does not warrant or represent that any license, either express or implied, is granted under any TI patent right, copyright, mask work right, or other TI intellectual property right relating to any combination, machine, or process in which TI products or services are used. Information published by TI regarding third-party products or services does not constitute a license from TI to use such products or services or a warranty or endorsement thereof. Use of such information may require a license from a third party under the patents or other intellectual property of the third party, or a license from TI under the patents or other intellectual property of TI.

Reproduction of TI information in TI data books or data sheets is permissible only if reproduction is without alteration and is accompanied by all associated warranties, conditions, limitations, and notices. Reproduction of this information with alteration is an unfair and deceptive business practice. TI is not responsible or liable for such altered documentation. Information of third parties may be subject to additional restrictions.

Resale of TI products or services with statements different from or beyond the parameters stated by TI for that product or service voids all express and any implied warranties for the associated TI product or service and is an unfair and deceptive business practice. TI is not responsible or liable for any such statements.

TI products are not authorized for use in safety-critical applications (such as life support) where a failure of the TI product would reasonably be expected to cause severe personal injury or death, unless officers of the parties have executed an agreement specifically governing such use. Buyers represent that they have all necessary expertise in the safety and regulatory ramifications of their applications, and acknowledge and agree that they are solely responsible for all legal, regulatory and safety-related requirements concerning their products and any use of TI products in such safety-critical applications, notwithstanding any applications-related information or support that may be provided by TI. Further, Buyers must fully indemnify TI and its representatives against any damages arising out of the use of TI products in such safety-critical applications.

TI products are neither designed nor intended for use in military/aerospace applications or environments unless the TI products are specifically designated by TI as military-grade or "enhanced plastic." Only products designated by TI as military-grade meet military specifications. Buyers acknowledge and agree that any such use of TI products which TI has not designated as military-grade is solely at the Buyer's risk, and that they are solely responsible for compliance with all legal and regulatory requirements in connection with such use.

TI products are neither designed nor intended for use in automotive applications or environments unless the specific TI products are designated by TI as compliant with ISO/TS 16949 requirements. Buyers acknowledge and agree that, if they use any non-designated products in automotive applications, TI will not be responsible for any failure to meet such requirements.

Following are URLs where you can obtain information on other Texas Instruments products and application solutions:

### Products

Amplifiers	<a href="http://amplifier.ti.com">amplifier.ti.com</a>
Data Converters	<a href="http://dataconverter.ti.com">dataconverter.ti.com</a>
DLP® Products	<a href="http://www.dlp.com">www.dlp.com</a>
DSP	<a href="http://dsp.ti.com">dsp.ti.com</a>
Clocks and Timers	<a href="http://www.ti.com/clocks">www.ti.com/clocks</a>
Interface	<a href="http://interface.ti.com">interface.ti.com</a>
Logic	<a href="http://logic.ti.com">logic.ti.com</a>
Power Mgmt	<a href="http://power.ti.com">power.ti.com</a>
Microcontrollers	<a href="http://microcontroller.ti.com">microcontroller.ti.com</a>
RFID	<a href="http://www.ti-rfid.com">www.ti-rfid.com</a>
RF/IF and ZigBee® Solutions	<a href="http://www.ti.com/lprf">www.ti.com/lprf</a>

### Applications

Audio	<a href="http://www.ti.com/audio">www.ti.com/audio</a>
Automotive	<a href="http://www.ti.com/automotive">www.ti.com/automotive</a>
Broadband	<a href="http://www.ti.com/broadband">www.ti.com/broadband</a>
Digital Control	<a href="http://www.ti.com/digitalcontrol">www.ti.com/digitalcontrol</a>
Medical	<a href="http://www.ti.com/medical">www.ti.com/medical</a>
Military	<a href="http://www.ti.com/military">www.ti.com/military</a>
Optical Networking	<a href="http://www.ti.com/opticalnetwork">www.ti.com/opticalnetwork</a>
Security	<a href="http://www.ti.com/security">www.ti.com/security</a>
Telephony	<a href="http://www.ti.com/telephony">www.ti.com/telephony</a>
Video & Imaging	<a href="http://www.ti.com/video">www.ti.com/video</a>
Wireless	<a href="http://www.ti.com/wireless">www.ti.com/wireless</a>

Mailing Address: Texas Instruments, Post Office Box 655303, Dallas, Texas 75265  
Copyright © 2009, Texas Instruments Incorporated