

DATA SHEET

For a complete data sheet, please also download:

- The IC04 LOCMOS HE4000B Logic Family Specifications HEF, HEC
- The IC04 LOCMOS HE4000B Logic Package Outlines/Information HEF, HEC

HEF4001B

gates

Quadruple 2-input NOR gate

Product specification
File under Integrated Circuits, IC04

January 1995

Quadruple 2-input NOR gate

HEF4001B
gates

DESCRIPTION

The HEF4001B provides the positive quadruple 2-input NOR function. The outputs are fully buffered for highest noise immunity and pattern insensitivity of output impedance.

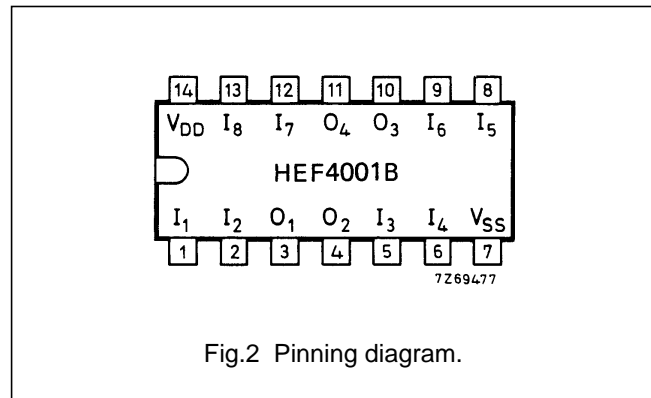
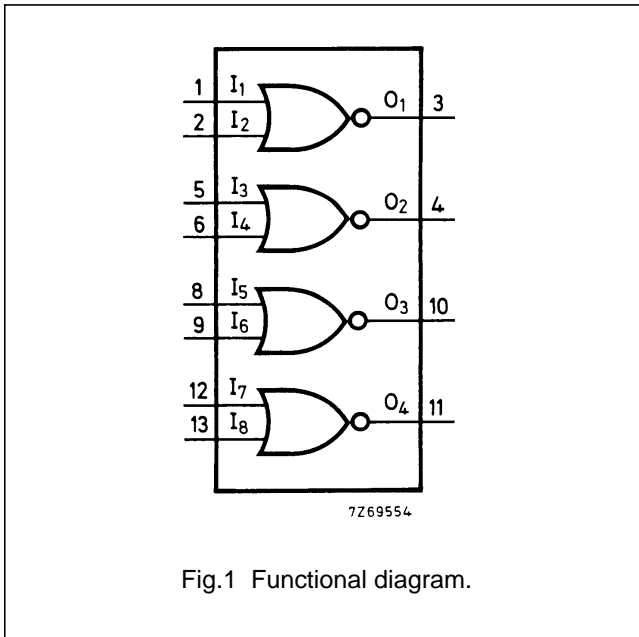

- HEF4001BP(N): 14-lead DIL; plastic (SOT27-1)
 - HEF4001BD(F): 14-lead DIL; ceramic (cerdip) (SOT73)
 - HEF4001BT(D): 14-lead SO; plastic (SOT108-1)
- () : Package Designator North America

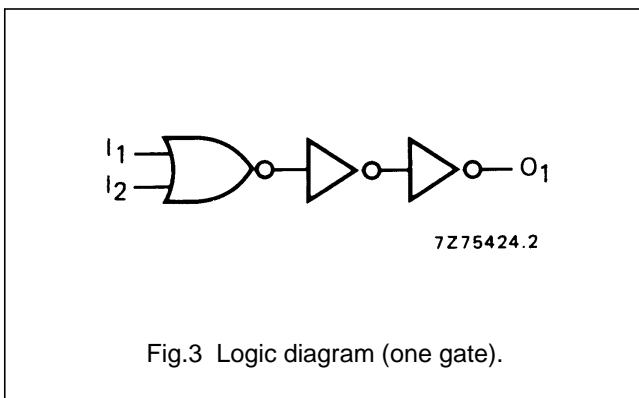

FAMILY DATA, I_{DD} LIMITS category GATES

See Family Specifications

Quadruple 2-input NOR gate

HEF4001B gates

AC CHARACTERISTICS

$V_{SS} = 0$ V; $T_{amb} = 25$ °C; $C_L = 50$ pF; input transition times ≤ 20 ns

	V_{DD} V	SYMBOL	TYP	MAX		TYPICAL EXTRAPOLATION FORMULA
Propagation delays $I_n \rightarrow O_n$ HIGH to LOW	5	t_{PHL}	60	120	ns	33 ns + (0,55 ns/pF) C_L
	10		25	50	ns	14 ns + (0,23 ns/pF) C_L
	15		20	40	ns	12 ns + (0,16 ns/pF) C_L
LOW to HIGH	5	t_{PLH}	50	100	ns	23 ns + (0,55 ns/pF) C_L
	10		25	45	ns	14 ns + (0,23 ns/pF) C_L
	15		20	35	ns	12 ns + (0,16 ns/pF) C_L
Output transition times HIGH to LOW	5	t_{THL}	60	120	ns	10 ns + (1,0 ns/pF) C_L
	10		30	60	ns	9 ns + (0,42 ns/pF) C_L
	15		20	40	ns	6 ns + (0,28 ns/pF) C_L
LOW to HIGH	5	t_{TLH}	60	120	ns	10 ns + (1,0 ns/pF) C_L
	10		30	60	ns	9 ns + (0,42 ns/pF) C_L
	15		20	40	ns	6 ns + (0,28 ns/pF) C_L

	V_{DD} V	TYPICAL FORMULA FOR P (μ W)	
Dynamic power dissipation per package (P)	5	$1100 f_i + \sum (f_o C_L) \times V_{DD}^2$	where f_i = input freq. (MHz) f_o = output freq. (MHz) C_L = load capacitance (pF) $\sum (f_o C_L)$ = sum of outputs V_{DD} = supply voltage (V)
	10	$5000 f_i + \sum (f_o C_L) \times V_{DD}^2$	
	15	$14\,200 f_i + \sum (f_o C_L) \times V_{DD}^2$	