

MC14553B

3-Digit BCD Counter

The MC14553B 3-digit BCD counter consists of 3 negative edge triggered BCD counters that are cascaded synchronously. A quad latch at the output of each counter permits storage of any given count. The information is then time division multiplexed, providing one BCD number or digit at a time. Digit select outputs provide display control. All outputs are TTL compatible.

An on-chip oscillator provides the low-frequency scanning clock which drives the multiplexer output selector.

This device is used in instrumentation counters, clock displays, digital panel meters, and as a building block for general logic applications.

- TTL Compatible Outputs
- On-Chip Oscillator
- Cascadable
- Clock Disable Input
- Pulse Shaping Permits Very Slow Rise Times on Input Clock
- Output Latches
- Master Reset

MAXIMUM RATINGS (Voltages Referenced to V_{SS}) (Note 1.)

Symbol	Parameter	Value	Unit
V_{DD}	DC Supply Voltage Range	-0.5 to +18.0	V
V_{in}, V_{out}	Input or Output Voltage Range (DC or Transient)	-0.5 to $V_{DD} + 0.5$	V
I_{in}	Input Current (DC or Transient) per Pin	± 10	mA
I_{out}	Output Current (DC or Transient) per Pin	+20	mA
P_D	Power Dissipation, per Package (Note 2.)	500	mW
T_A	Ambient Temperature Range	-55 to +125	$^{\circ}C$
T_{stg}	Storage Temperature Range	-65 to +150	$^{\circ}C$
T_L	Lead Temperature (8-Second Soldering)	260	$^{\circ}C$

1. Maximum Ratings are those values beyond which damage to the device may occur.
2. Temperature Derating:
Plastic "P and D/DW" Packages: - 7.0 mW/ $^{\circ}C$ From 65 $^{\circ}C$ To 125 $^{\circ}C$

This device contains protection circuitry to guard against damage due to high static voltages or electric fields. However, precautions must be taken to avoid applications of any voltage higher than maximum rated voltages to this high-impedance circuit. For proper operation, V_{in} and V_{out} should be constrained to the range $V_{SS} \leq (V_{in} \text{ or } V_{out}) \leq V_{DD}$.

Unused inputs must always be tied to an appropriate logic voltage level (e.g., either V_{SS} or V_{DD}). Unused outputs must be left open.



ON Semiconductor

<http://onsemi.com>

MARKING DIAGRAMS

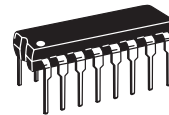

PDIP-16
P SUFFIX
CASE 648

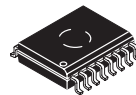
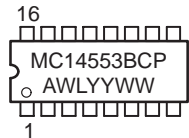

SOIC-16
DW SUFFIX
CASE 751G

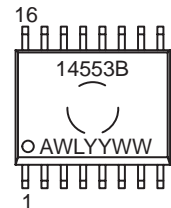

A = Assembly Location
WL or L = Wafer Lot
YY or Y = Year
WW or W = Work Week

ORDERING INFORMATION

Device	Package	Shipping
MC14553BCP	PDIP-16	25/Rail
MC14553BDW	SOIC-16	47/Rail

MC14553B

BLOCK DIAGRAM

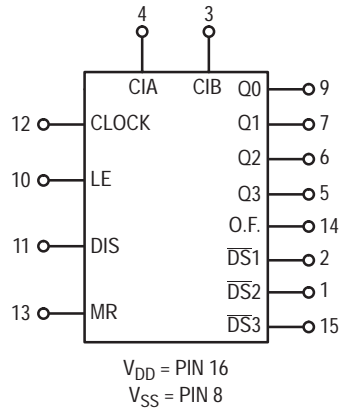

TRUTH TABLE

Inputs				Outputs
Master Reset	Clock	Disable	LE	
0		0	0	No Change
0		0	0	Advance
0	X	1	X	No Change
0	1		0	Advance
0	1		0	No Change
0	0	X	X	No Change
0	X	X		Latched
0	X	X	1	Latched
1	X	X	0	Q0 = Q1 = Q2 = Q3 = 0

X = Don't Care

MC14553B

ELECTRICAL CHARACTERISTICS (Voltages Referenced to V_{SS})

Characteristic	Symbol	V _{DD} Vdc	- 55°C		25°C			125°C		Unit		
			Min	Max	Min	Typ ^(3.)	Max	Min	Max			
Output Voltage V _{in} = V _{DD} or 0 V _{in} = 0 or V _{DD}	"0" Level V _{OL}	5.0	—	0.05	—	0	0.05	—	0.05	Vdc		
		10	—	0.05	—	0	0.05	—	0.05			
		15	—	0.05	—	0	0.05	—	0.05			
	"1" Level V _{OH}	5.0	4.95	—	4.95	5.0	—	4.95	—	Vdc		
		10	9.95	—	9.95	10	—	9.95	—			
		15	14.95	—	14.95	15	—	14.95	—			
Input Voltage "0" Level (V _O = 4.5 or 0.5 Vdc) (V _O = 9.0 or 1.0 Vdc) (V _O = 13.5 or 1.5 Vdc) "1" Level (V _O = 0.5 or 4.5 Vdc) (V _O = 1.0 or 9.0 Vdc) (V _O = 1.5 or 13.5 Vdc)	V _{IL}	5.0	—	1.5	—	2.25	1.5	—	1.5	Vdc		
		10	—	3.0	—	4.50	3.0	—	3.0			
		15	—	4.0	—	6.75	4.0	—	4.0			
	V _{IH}	5.0	3.5	—	3.5	2.75	—	3.5	—	Vdc		
		10	7.0	—	7.0	5.50	—	7.0	—			
		15	11	—	11	8.25	—	11	—			
Output Drive Current (V _{OH} = 4.6 Vdc) (V _{OH} = 9.5 Vdc) (V _{OH} = 13.5 Vdc) (V _{OH} = 4.6 Vdc) (V _{OH} = 9.5 Vdc) (V _{OH} = 13.5 Vdc) (V _{OL} = 0.4 Vdc) (V _{OL} = 0.5 Vdc) (V _{OL} = 1.5 Vdc) (V _{OL} = 0.4 Vdc) (V _{OL} = 0.5 Vdc) (V _{OL} = 1.5 Vdc)	Source — Pin 3	I _{OH}	5.0	-0.25	—	-0.2	-0.36	—	0.14	—	mAdc	
			10	-0.62	—	-0.5	-0.9	—	0.35	—		
			15	-1.8	—	-1.5	-3.5	—	1.1	—		
		Source — Other Outputs	I _{OH}	5.0	-0.64	—	-0.51	-0.88	—	-0.36	—	mAdc
				10	-1.6	—	-1.3	-2.25	—	-0.9	—	
				15	-4.2	—	-3.4	-8.8	—	-2.4	—	
	Sink — Pin 3 Sink — Other Outputs	I _{OL}	5.0	0.5	—	0.4	0.88	—	0.28	—	mAdc	
			10	1.1	—	0.9	2.25	—	0.65	—		
			15	1.8	—	1.5	8.8	—	1.20	—		
		Sink — Other Outputs	I _{OL}	5.0	3.0	—	2.5	4.0	—	1.6	—	mAdc
				10	6.0	—	5.0	8.0	—	3.5	—	
				15	18	—	15	20	—	10	—	
Input Current	I _{in}	15	—	±0.1	—	±0.00001	±0.1	—	±1.0	μAdc		
Input Capacitance (V _{in} = 0)	C _{in}	—	—	—	—	5.0	7.5	—	—	pF		
Quiescent Current (Per Package) MR = V _{DD}	I _{DD}	5.0	—	5.0	—	0.010	5.0	—	150	μAdc		
		10	—	10	—	0.020	10	—	300			
		15	—	20	—	0.030	20	—	600			
Total Supply Current ^(4.) ^(5.) (Dynamic plus Quiescent, Per Package) (C _L = 50 pF on all outputs, all buffers switching)	I _T	5.0 10 15	I _T = (0.35 μA/kHz) f + I _{DD} I _T = (0.85 μA/kHz) f + I _{DD} I _T = (1.50 μA/kHz) f + I _{DD}							μAdc		

3. Data labelled "Typ" is not to be used for design purposes but is intended as an indication of the IC's potential performance.

4. The formulas given are for the typical characteristics only at 25°C.

5. To calculate total supply current at loads other than 50 pF:

$$I_T(C_L) = I_T(50 \text{ pF}) + (C_L - 50) Vfk$$

where: I_T is in μA (per package), C_L in pF, V = (V_{DD} - V_{SS}) in volts, f in kHz is input frequency, and k = 0.004.

MC14553B

SWITCHING CHARACTERISTICS ^(6.) ($C_L = 50 \text{ pF}$, $T_A = 25^\circ\text{C}$)

Characteristic	Figure	Symbol	V_{DD}	Min	Typ ^(7.)	Max	Unit
Output Rise and Fall Time t_{TLH} , $t_{THL} = (1.5 \text{ ns/pF}) C_L + 25 \text{ ns}$ t_{TLH} , $t_{THL} = (0.75 \text{ ns/pF}) C_L + 12.5 \text{ ns}$ t_{TLH} , $t_{THL} = (0.55 \text{ ns/pF}) C_L + 9.5 \text{ ns}$	2a	t_{TLH} , t_{THL}	5.0 10 15	— — —	100 50 40	200 100 80	ns
Clock to BCD Out	2a	t_{PLH} , t_{PHL}	5.0 10 15	— — —	900 500 200	1800 1000 400	ns
Clock to Overflow	2a	t_{PHL}	5.0 10 15	— — —	600 400 200	1200 800 400	ns
Reset to BCD Out	2b	t_{PHL}	5.0 10 15	— — —	900 500 300	1800 1000 600	ns
Clock to Latch Enable Setup Time Master Reset to Latch Enable Setup Time	2b	t_{su}	5.0 10 15	600 400 200	300 200 100	— — —	ns
Removal Time Latch Enable to Clock	2b	t_{rem}	5.0 10 15	-80 -10 0	-200 -70 -50	— — —	ns
Clock Pulse Width	2a	$t_{WH(cl)}$	5.0 10 15	550 200 150	275 100 75	— — —	ns
Reset Pulse Width	2b	$t_{WH(R)}$	5.0 10 15	1200 600 450	600 300 225	— — —	ns
Reset Removal Time	—	t_{rem}	5.0 10 15	-80 0 20	-180 -50 -30	— — —	ns
Input Clock Frequency	2a	f_{cl}	5.0 10 15	— — —	1.5 5.0 7.0	0.9 2.5 3.5	MHz
Input Clock Rise Time	2b	t_{TLH}	5.0 10 15	No Limit			ns
Disable, MR, Latch Enable Rise and Fall Times	—	t_{TLH} , t_{THL}	5.0 10 15	— — —	— — —	15 5.0 4.0	μs
Scan Oscillator Frequency (C1 measured in μF)	1	f_{osc}	5.0 10 15	— — —	1.5/C1 4.2/C1 7.0/C1	— — —	Hz

6. The formulas given are for the typical characteristics only at 25°C .

7. Data labelled "Typ" is not to be used for design purposes but is intended as an indication of the IC's potential performance.

MC14553B

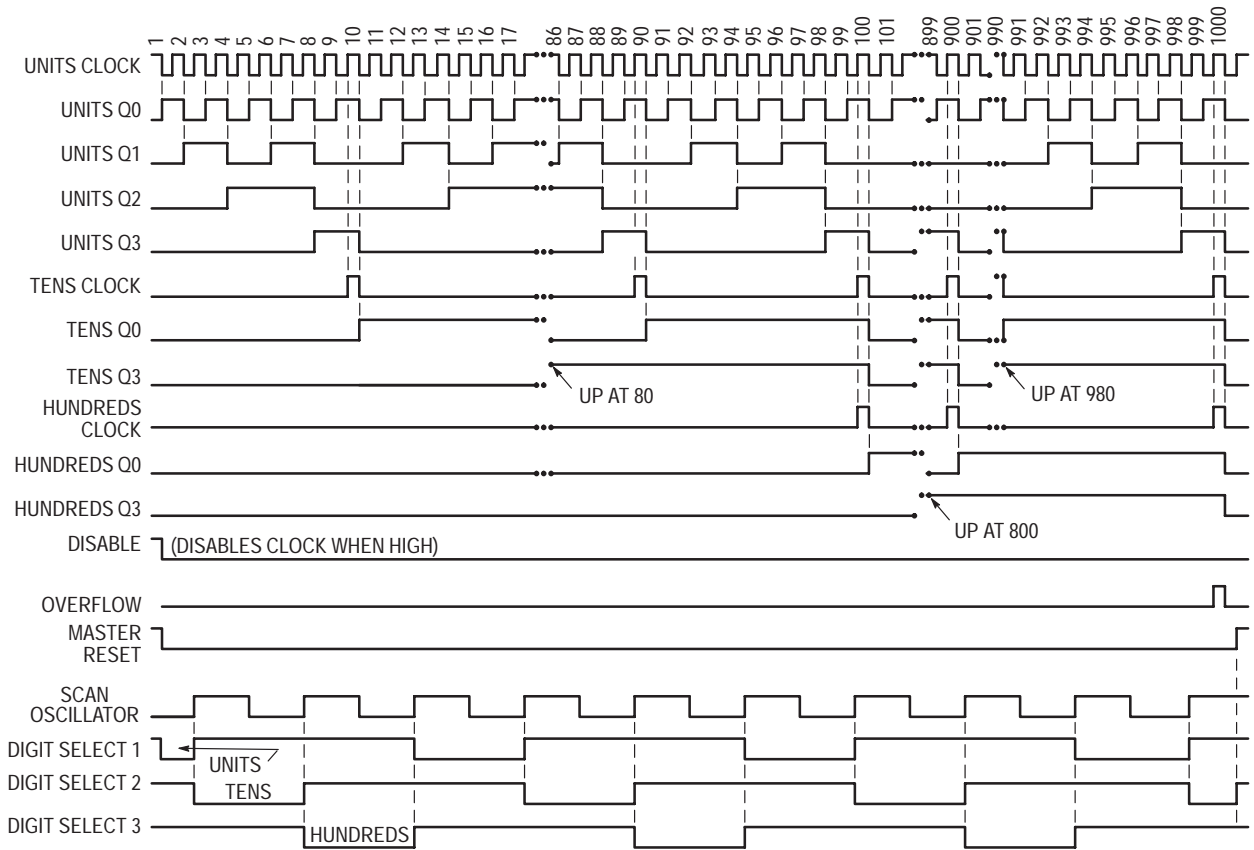

Figure 1. 3-Digit Counter Timing Diagram (Reference Figure 3)

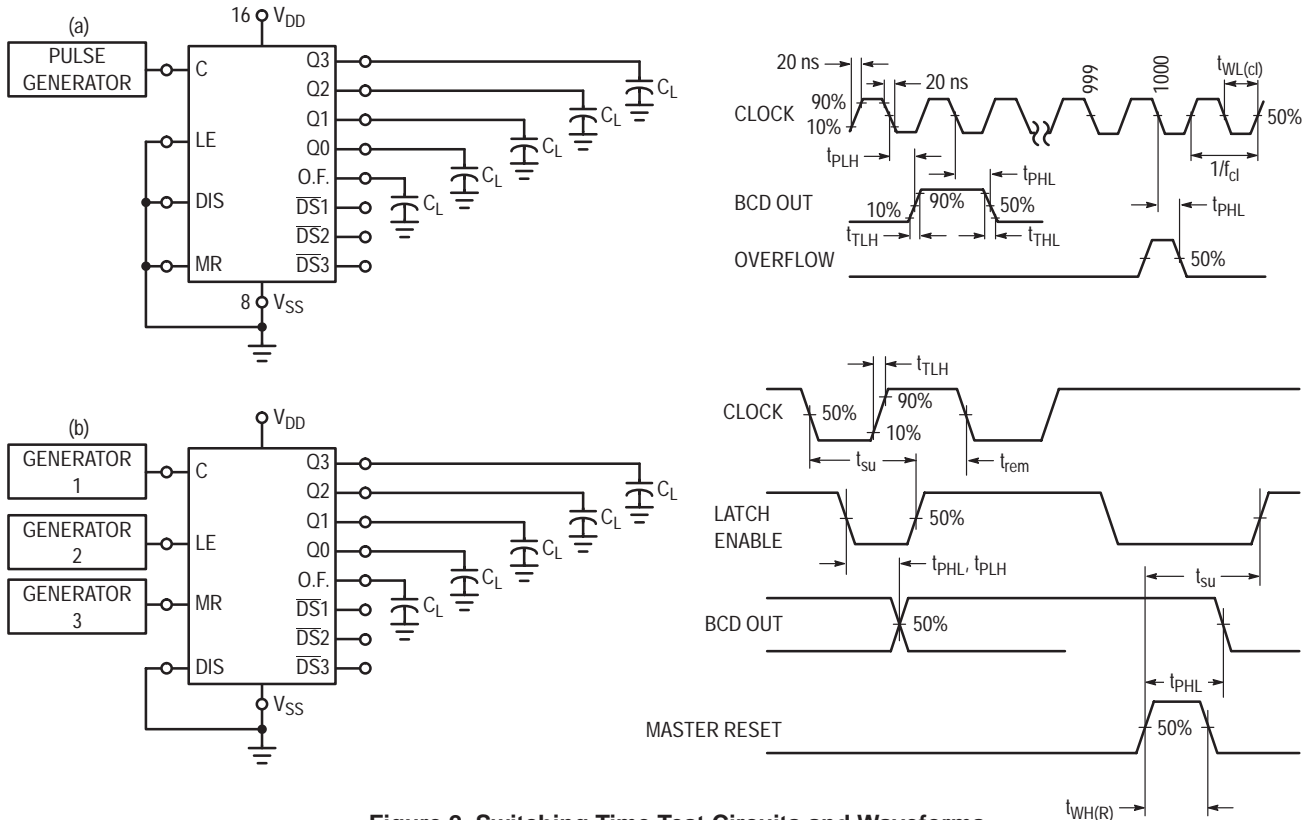

Figure 2. Switching Time Test Circuits and Waveforms

OPERATING CHARACTERISTICS

The MC14553B three-digit counter, shown in Figure 3, consists of three negative edge-triggered BCD counters which are cascaded in a synchronous fashion. A quad latch at the output of each of the three BCD counters permits storage of any given count. The three sets of BCD outputs (active high), after going through the latches, are time division multiplexed, providing one BCD number or digit at a time. Digit select outputs (active low) are provided for display control. All outputs are TTL compatible.

An on-chip oscillator provides the low frequency scanning clock which drives the multiplexer output selector. The frequency of the oscillator can be controlled externally by a capacitor between pins 3 and 4, or it can be overridden and driven with an external clock at pin 4. Multiple devices can be cascaded using the overflow output, which provides one pulse for every 1000 counts.

The Master Reset input, when taken high, initializes the three BCD counters and the multiplexer scanning circuit. While Master Reset is high the digit scanner is set to digit one; but all three digit select outputs are disabled to prolong display life, and the scan oscillator is inhibited. The Disable input, when high, prevents the input clock from reaching the counters, while still retaining the last count. A pulse shaping circuit at the clock input permits the counters to continue operating on input pulses with very slow rise times. Information present in the counters when the latch input goes high, will be stored in the latches and will be retained while the latch input is high, independent of other inputs. Information can be recovered from the latches after the counters have been reset if Latch Enable remains high during the entire reset cycle.

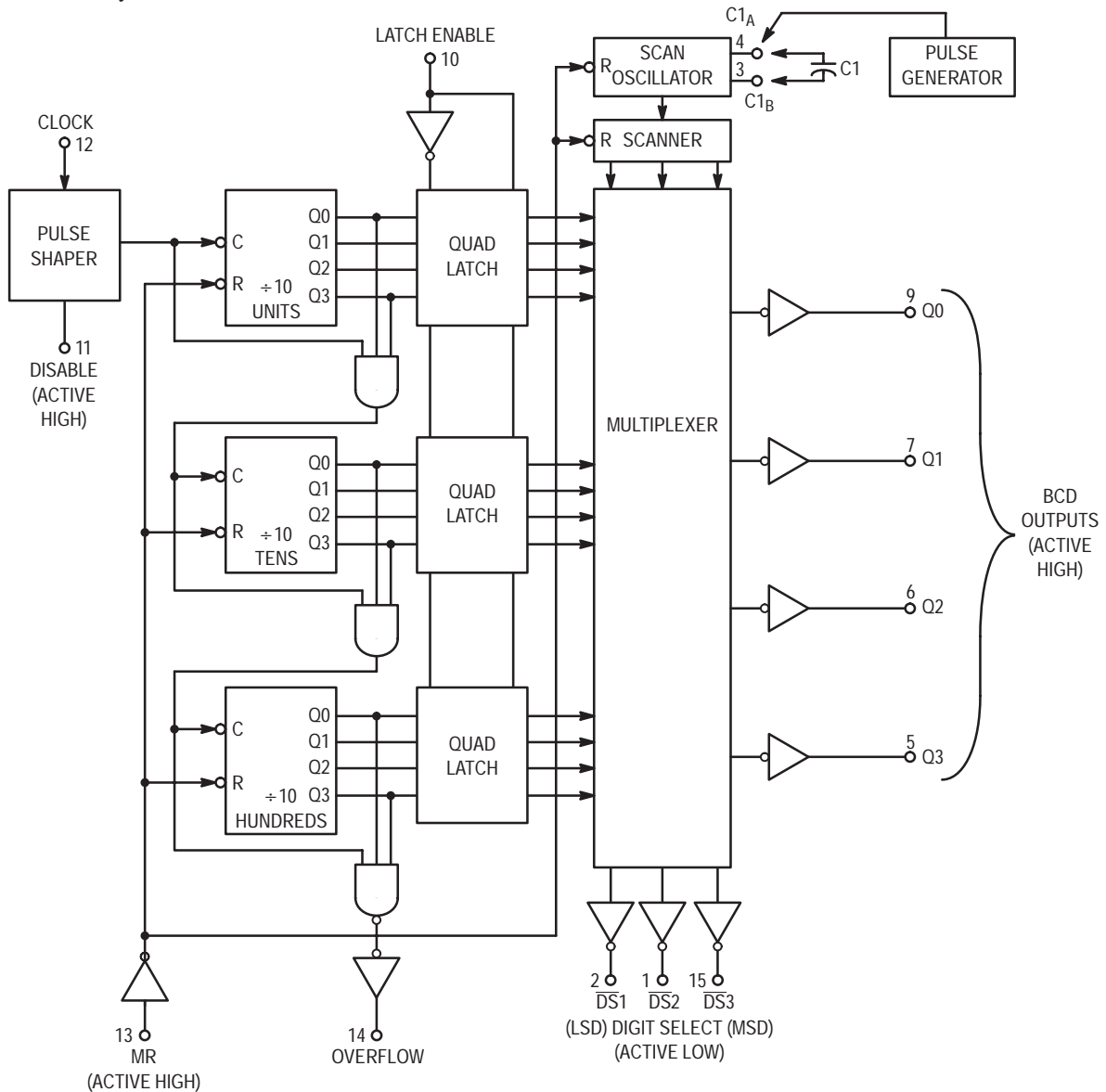

Figure 3. Expanded Block Diagram

MC14553B

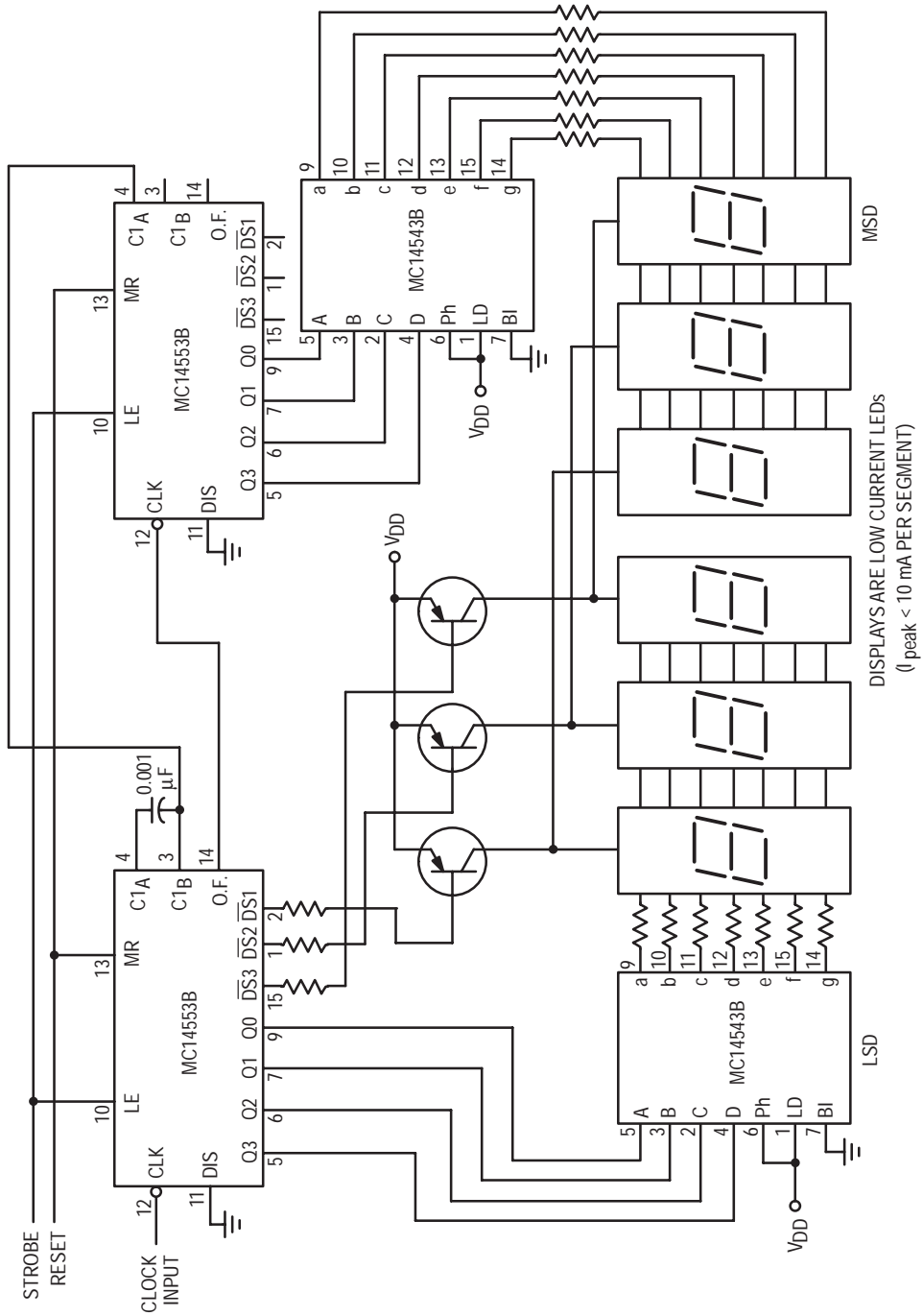
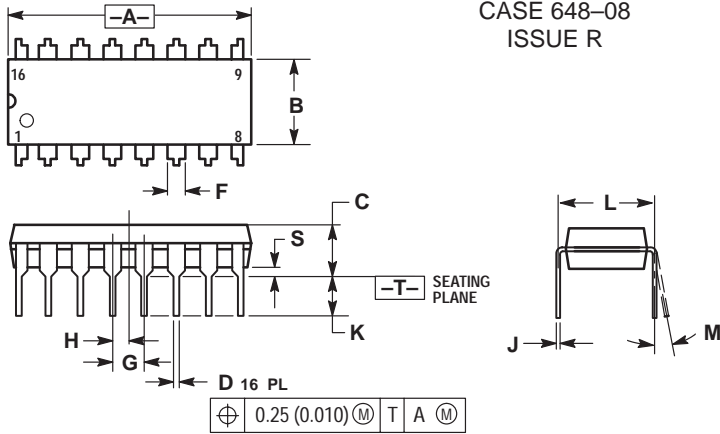

Figure 4. Six-Digit Display

MC14553B

PACKAGE DIMENSIONS

PDIP-16
P SUFFIX
PLASTIC DIP PACKAGE
CASE 648-08
ISSUE R



NOTES:

1. DIMENSIONING AND TOLERANCING PER ANSI Y14.5M, 1982.
2. CONTROLLING DIMENSION: INCH.
3. DIMENSION L TO CENTER OF LEADS WHEN FORMED PARALLEL.
4. DIMENSION B DOES NOT INCLUDE MOLD FLASH.
5. ROUNDED CORNERS OPTIONAL.

DIM	INCHES		MILLIMETERS	
	MIN	MAX	MIN	MAX
A	0.740	0.770	18.80	19.55
B	0.250	0.270	6.35	6.85
C	0.145	0.175	3.69	4.44
D	0.015	0.021	0.39	0.53
F	0.040	0.70	1.02	1.77
G	0.100 BSC		2.54 BSC	
H	0.050 BSC		1.27 BSC	
J	0.008	0.015	0.21	0.38
K	0.110	0.130	2.80	3.30
L	0.295	0.305	7.50	7.74
M	0°	10°	0°	10°
S	0.020	0.040	0.51	1.01

MC14553B

PACKAGE DIMENSIONS

SOIC-16
DW SUFFIX
PLASTIC SOIC PACKAGE
CASE 751G-03
ISSUE B

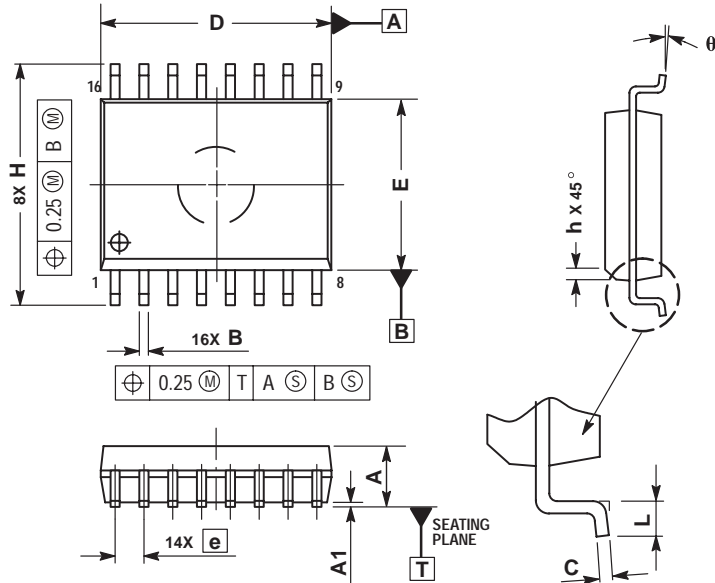

NOTES:

1. DIMENSIONS ARE IN MILLIMETERS.
2. INTERPRET DIMENSIONS AND TOLERANCES PER ASME Y14.5M, 1994.
3. DIMENSIONS D AND E DO NOT INCLUDE MOLD PROTRUSION.
4. MAXIMUM MOLD PROTRUSION 0.15 PER SIDE.
5. DIMENSION B DOES NOT INCLUDE DAMBAR PROTRUSION. ALLOWABLE DAMBAR PROTRUSION SHALL BE 0.13 TOTAL IN EXCESS OF THE B DIMENSION AT MAXIMUM MATERIAL CONDITION.

DIM	MILLIMETERS	
	MIN	MAX
A	2.35	2.65
A1	0.10	0.25
B	0.35	0.49
C	0.23	0.32
D	10.15	10.45
E	7.40	7.60
e	1.27 BSC	
H	10.05	10.55
h	0.25	0.75
L	0.50	0.90
θ	0°	7°

Notes

Notes

ON Semiconductor and  are trademarks of Semiconductor Components Industries, LLC (SCILLC). SCILLC reserves the right to make changes without further notice to any products herein. SCILLC makes no warranty, representation or guarantee regarding the suitability of its products for any particular purpose, nor does SCILLC assume any liability arising out of the application or use of any product or circuit, and specifically disclaims any and all liability, including without limitation special, consequential or incidental damages. "Typical" parameters which may be provided in SCILLC data sheets and/or specifications can and do vary in different applications and actual performance may vary over time. All operating parameters, including "Typicals" must be validated for each customer application by customer's technical experts. SCILLC does not convey any license under its patent rights nor the rights of others. SCILLC products are not designed, intended, or authorized for use as components in systems intended for surgical implant into the body, or other applications intended to support or sustain life, or for any other application in which the failure of the SCILLC product could create a situation where personal injury or death may occur. Should Buyer purchase or use SCILLC products for any such unintended or unauthorized application, Buyer shall indemnify and hold SCILLC and its officers, employees, subsidiaries, affiliates, and distributors harmless against all claims, costs, damages, and expenses, and reasonable attorney fees arising out of, directly or indirectly, any claim of personal injury or death associated with such unintended or unauthorized use, even if such claim alleges that SCILLC was negligent regarding the design or manufacture of the part. SCILLC is an Equal Opportunity/Affirmative Action Employer.

PUBLICATION ORDERING INFORMATION

NORTH AMERICA Literature Fulfillment:

Literature Distribution Center for ON Semiconductor
P.O. Box 5163, Denver, Colorado 80217 USA
Phone: 303-675-2175 or 800-344-3860 Toll Free USA/Canada
Fax: 303-675-2176 or 800-344-3867 Toll Free USA/Canada
Email: ONlit@hibbertco.com
Fax Response Line: 303-675-2167 or 800-344-3810 Toll Free USA/Canada

N. American Technical Support: 800-282-9855 Toll Free USA/Canada

EUROPE: LDC for ON Semiconductor – European Support

German Phone: (+1) 303-308-7140 (M-F 1:00pm to 5:00pm Munich Time)
Email: ONlit-german@hibbertco.com
French Phone: (+1) 303-308-7141 (M-F 1:00pm to 5:00pm Toulouse Time)
Email: ONlit-french@hibbertco.com
English Phone: (+1) 303-308-7142 (M-F 12:00pm to 5:00pm UK Time)
Email: ONlit@hibbertco.com

EUROPEAN TOLL-FREE ACCESS*: 00-800-4422-3781

*Available from Germany, France, Italy, England, Ireland

CENTRAL/SOUTH AMERICA:

Spanish Phone: 303-308-7143 (Mon-Fri 8:00am to 5:00pm MST)
Email: ONlit-spanish@hibbertco.com

ASIA/PACIFIC: LDC for ON Semiconductor – Asia Support

Phone: 303-675-2121 (Tue-Fri 9:00am to 1:00pm, Hong Kong Time)
Toll Free from Hong Kong & Singapore:
001-800-4422-3781
Email: ONlit-asia@hibbertco.com

JAPAN: ON Semiconductor, Japan Customer Focus Center
4-32-1 Nishi-Gotanda, Shinagawa-ku, Tokyo, Japan 141-8549

Phone: 81-3-5740-2745
Email: r14525@onsemi.com

ON Semiconductor Website: <http://onsemi.com>

For additional information, please contact your local Sales Representative.