

2.7 V TO 5.5 V 12-BIT PARALLEL DIGITAL-TO-ANALOG CONVERTER WITH POWER DOWN

FEATURES

- Single Supply 2.7-V to 5.5-V Operation
- ± 0.4 LSB Differential Nonlinearity (DNL), ± 1.5 LSB Integral Nonlinearity (INL)
- 12-Bit Parallel Interface
- Compatible With TMS320 DSP
- Internal Power On Reset
- Settling Time 1 μ s Typ
- Low Power Consumption:
 - 8 mW for 5-V Supply
 - 4.3 mW for 3-V Supply
- Reference Input Buffers
- Voltage Output
- Monotonic Over Temperature
- Asynchronous Update

APPLICATIONS

- Battery Powered Test Instruments
- Digital Offset and Gain Adjustment
- Battery Operated/Remote Industrial Controls
- Machine and Motion Control Devices
- Cordless and Wireless Telephones
- Speech Synthesis
- Communication Modulators
- Arbitrary Waveform Generation

DESCRIPTION

The TLV5619 is a 12-bit voltage output DAC with a microprocessor and TMS320 compatible parallel interface. The 12 data bits are double buffered so that the output can be updated asynchronously using the $\overline{\text{LDAC}}$ pin. During normal operation, the device dissipates 8 mW at a 5-V supply and 4.3 mW at a 3-V supply. The power consumption can be lowered to 50 nW by setting the DAC to power-down mode.

The output voltage is buffered by a $\times 2$ gain rail-to-rail amplifier, which features a Class A output stage to improve stability and reduce settling time.

**DW OR PW PACKAGE
(TOP VIEW)**

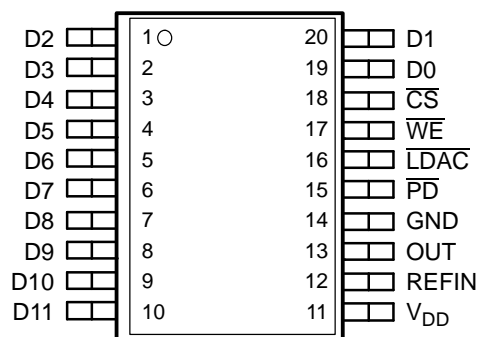

AVAILABLE OPTIONS

PACKAGE		
T_A	SMALL OUTLINE (DW)	TSSOP (PW)
0°C to 70°C	TLV5619CDW	TLV5619CPW
40°C to 85°C	TLV5619IDW	TLV5619IPW
40°C to 125°C	TLV5619QDW	—



Please be aware that an important notice concerning availability, standard warranty, and use in critical applications of Texas Instruments semiconductor products and disclaimers thereto appears at the end of this data sheet.



These devices have limited built-in ESD protection. The leads should be shorted together or the device placed in conductive foam during storage or handling to prevent electrostatic damage to the MOS gates.

FUNCTIONAL BLOCK DIAGRAM

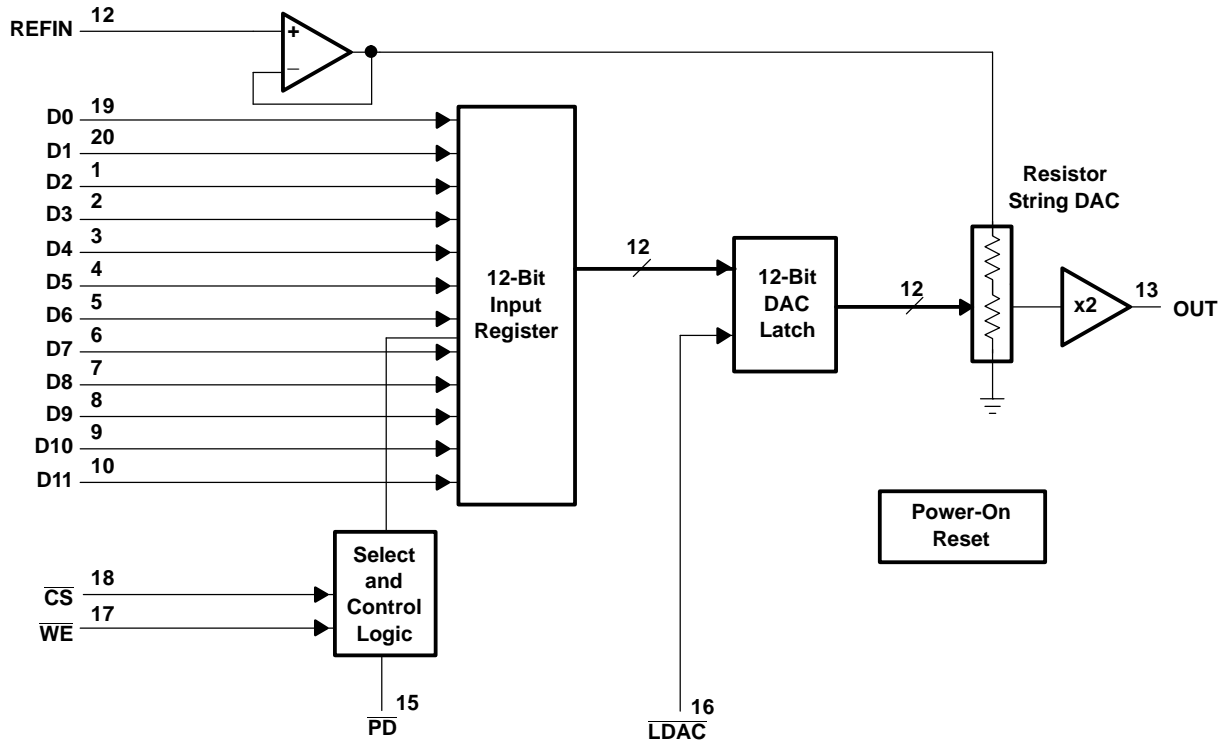

Terminal Functions

NAME	TERMINAL NO.	I/O	DESCRIPTION
\overline{CS}	18	I	Chip select
D0 (LSB)-D11 (MSB)	19, 20, 1-10	I	Parallel data input
GND	14		Ground
\overline{LDAC}	16	I	Load DAC
OUT	13	O	Analog output
\overline{PD}	15	I	When low, disables all buffer amplifier voltages to reduce supply current
REFIN	12	I	Voltage reference input
V_{DD}	11		Positive power supply
\overline{WE}	17	I	Write enable

ABSOLUTE MAXIMUM RATINGS

over operating free-air temperature range (unless otherwise noted)⁽¹⁾

		UNIT
Supply voltage (V_{DD} to GND)		7 V
Analog input voltage range		- 0.3 V to $V_{DD} + 0.3$ V
Reference input voltage		$V_{DD} + 0.3$ V
Digital input voltage range to GND		- 0.3 V to $V_{DD} + 0.3$ V
Operating free-air temperature range, T_A	TLV5619C	0°C to 70°C
	TLV5619I	-40°C to 85°C
	TLV5619Q	-40°C to 125°C
Storage temperature range, T_{stg}		-65°C to 150°C
Lead temperature 1,6 mm (1/16 inch) from case for 10 seconds		260°C

(1) Stresses beyond those listed under „ absolute maximum ratings” may cause permanent damage to the device. These are stress ratings only, and functional operation of the device at these or any other conditions beyond those indicated under „ recommended operating conditions” is not implied. Exposure to absolute-maximum-rated conditions for extended periods may affect device reliability.

RECOMMENDED OPERATING CONDITIONS

		MIN	NOM	MAX	UNIT
Supply voltage, V_{DD} (5-V Supply)		4.5	5	5.5	V
Supply voltage, V_{DD} (3-V Supply)		2.7	3	3.3	V
High-level digital input voltage, V_{IH}	$DV_{DD} = 2.7$ V	2			V
	$DV_{DD} = 5.5$ V	2.4			
Low-level digital input voltage, V_{IL}	$DV_{DD} = 2.7$ V	0.6			V
	$DV_{DD} = 5.5$ V	TLV5619C and TLV5619I		1	
		TLV5619Q		0.8	
Reference voltage, V_{ref} to REFIN terminal (5-V Supply)		0	2.048	$V_{DD}-1.5$	V
Reference voltage, V_{ref} to REFIN terminal (3-V Supply)		0	1.024	$V_{DD}-1.5$	V
Load resistance, R_L		2	10		k Ω
Load capacitance, C_L				100	pF
Operating free-air temperature, T_A	TLV5619C	0		70	°C
	TLV5619I	40		85	
	TLV5619Q	40		125	

ELECTRICAL CHARACTERISTICS

over recommended operating free-air temperature range, supply voltages, and reference voltages (unless otherwise noted)

STATIC DAC SPECIFICATIONS							
PARAMETER		TEST CONDITIONS		MIN	TYP	MAX	UNIT
Resolution		$V_{ref(REFIN)} = 2.048\text{ V at } 5\text{ V}, 1.024\text{ V at } 3\text{ V}$		12			bits
Integral nonlinearity (INL)		$V_{ref(REFIN)} = 2.048\text{ V at } 5\text{ V}, 1.024\text{ V at } 3\text{ V},$ See (1)			±1.5	±4	LSB
Differential nonlinearity (DNL)		$V_{ref(REFIN)} = 2.048\text{ V at } 5\text{ V}, 1.024\text{ V at } 3\text{ V},$ See (2)			±0.4	±1	LSB
E_{ZS}	Zero-scale error (offset error at zero scale)	$V_{ref(REFIN)} = 2.048\text{ V at } 5\text{ V}, 1.024\text{ V at } 3\text{ V},$ See (3)			±3	±20	mV
Zero-scale-error temperature coefficient		$V_{ref(REFIN)} = 2.048\text{ V at } 5\text{ V}, 1.024\text{ V at } 3\text{ V},$ See (4)			3		ppm/°C
E_G	Gain error	$V_{ref(REFIN)} = 2.048\text{ V at } 5\text{ V}, 1.024\text{ V at } 3\text{ V},$ See (5)			±0.25	±0.5	% of FS voltage
Gain error temperature coefficient		$V_{ref(REFIN)} = 2.048\text{ V at } 5\text{ V}, 1.024\text{ V at } 3\text{ V},$ See (6)			1		ppm/°C
PSRR	Power-supply rejection ratio	Zero scale	See (7) and (8)		65		dB
		Gain			65		

- (1) The relative accuracy or integral nonlinearity (INL), sometimes referred to as linearity error, is the maximum deviation of the output from the line between zero and full scale excluding the effects of zero code and full-scale errors.
- (2) The differential nonlinearity (DNL), sometimes referred to as differential error, is the difference between the measured and ideal 1 LSB amplitude change of any two adjacent codes. Monotonic means the output voltage changes in the same direction (or remains constant) as a change in the digital input code.
- (3) Zero-scale error is the deviation from zero voltage output when the digital input code is zero.
- (4) Zero-scale-error temperature coefficient is given by: $E_{ZS}\text{ TC} = [E_{ZS}(T_{max}) - E_{ZS}(T_{min})]/V_{ref} \times 10^6/(T_{max} - T_{min})$.
- (5) Gain error is the deviation from the ideal output ($2 \times V_{ref} - 1\text{ LSB}$) with an output load of 10 kΩ excluding the effects of the zero-error.
- (6) Gain temperature coefficient is given by: $E_G\text{ TC} = [E_G(T_{max}) - E_G(T_{min})]/V_{ref} \times 10^6/(T_{max} - T_{min})$.
- (7) Zero-scale-error rejection ratio (EZR-RR) is measured by varying the V_{DD} from 4.5 V to 5.5 V dc and measuring the proportion of this signal imposed on the zero-code output voltage.
- (8) Gain-error rejection ratio (EG-RR) is measured by varying the V_{DD} from 4.5 V to 5.5 V dc and measuring the proportion of this signal imposed on the full-scale output voltage after subtracting the zero scale change.

OUTPUT SPECIFICATIONS							
PARAMETER		TEST CONDITIONS		MIN	TYP	MAX	UNIT
V_O	Voltage output range	$R_L = 10\text{ k}\Omega$		0		$V_{DD}-0.4$	V
Output load regulation accuracy		$V_{O(OUT)} = 4.096\text{ V}, 2.048\text{ V}$ $R_L = 2\text{ k}\Omega$			0.1	0.29	% of FS voltage
$I_{OSC(source)}$	Output short circuit source current	$V_{O(OUT)} = 0\text{ V},$ Full scale code	5-V Supply	100			mA
			3-V Supply	25			
$I_{O(source)}$	Output source current	$R_L = 100\Omega$	5-V Supply	10			mA
			3-V Supply	10			

REFERENCE INPUT (REFIN)					
PARAMETER	TEST CONDITIONS	MIN	TYP	MAX	UNIT
V _{ref}	Reference input voltage	See (1)	0	V _{DD} -1.5	V
R _i	Reference input resistance		10		MΩ
C _i	Reference input capacitance		5		pF
	Reference feed through	REFIN = 1 V _{pp} at 1 kHz + 1.024 V dc (see (2))	60		dB
	Reference input bandwidth	REFIN = 0.2 V _{pp} + 1.024 V dc at -3 dB	1.4		MHz
DIGITAL INPUTS (D0-D11, \overline{CS} , \overline{WE} , \overline{LDAC} , \overline{PD})					
I _{IH}	High-level digital input current	V _I = V _{DD}		1	μA
I _{IL}	Low-level digital input current	V _I = 0 V		1	μA
C _i	Input capacitance		8		pF

(1) Reference input voltages greater than V_{DD}/2 will cause output saturation for large DAC codes.

(2) Reference feedthrough is measured at the DAC output with an input code = 0x000 and a V_{ref(REFIN)} input = 1.024 V dc + 1 V_{pp} at 1 kHz.

POWER SUPPLY						
PARAMETER	TEST CONDITIONS	MIN	TYP	MAX	UNIT	
I _{DD}	Power supply current	No load, All inputs 0 V or V _{DD}	5-V Supply	1.6	3	mA
			3-V Supply	1.44	2.7	
	Power down supply current		0.01	10	μA	

ANALOG OUTPUT DYNAMIC PERFORMANCE							
PARAMETER	TEST CONDITIONS	MIN	TYP	MAX	UNIT		
SR	Slew rate	C _L = 100 pF, R _L = 10 kΩ	V _{ref(REFIN)} = 2.048 V, V _{ref(REFIN)} = 1.024 V, V _O from 10% to 90% V _O from 90% to 10%	5-V Supply	8	12	V/μs
				3-V Supply	6	9	V/μs
t _s	Output settling time (full scale)	To ±0.5 LSB, R _L = 10 kΩ, C _L = 100 pF, See (1)			1	3	μs
	Glitch energy	DIN = all 0s to all 1s			5		nV-s
S/N	Signal to noise	f _s = 480 kSPS, BW = 20 kHz, C _L = 100 pF, f _{OUT} = 1 kHz, R _L = 10 kΩ, T _A = 25°C, See (2)	5-V Supply	65	78	dB	
S/(N+D)	Signal to noise + distortion	f _s = 480 kSPS, BW = 20 kHz, C _L = 100 pF, f _{OUT} = 1 kHz, R _L = 10 kΩ, T _A = 25°C, See (2)	5-V Supply	58	67		
			3-V Supply	58	69		
	Total harmonic distortion	f _s = 480 kSPS, BW = 20 kHz, C _L = 100 pF, f _{OUT} = 1 kHz, R _L = 10 kΩ, T _A = 25°C, See (2)		68	60		
	Spurious free dynamic range	f _s = 480 kSPS, BW = 20 kHz, C _L = 100 pF, f _{OUT} = 1 kHz, R _L = 10 kΩ, T _A = 25°C, See (2)		60	72		

(1) Settling time is the time for the output signal to remain within ±0.5 LSB of the final measured value for a digital input code change of 32 to 4063 or 4063 to 32. Limits are ensured by design and characterization, but are not production tested.

(2) 1 kHz sinewave generated by DAC, reference voltage = 1.024 V at 3 V and 2.048 V at 5 V.

TIMING REQUIREMENTS

DIGITAL INPUTS		MIN	NOM	MAX	UNIT
t _{su(CS-WE)}	Setup time, \overline{CS} low before positive \overline{WE} edge	13			ns
t _{su(D)}	Setup time, data ready before positive \overline{WE} edge	9			ns
t _{h(D)}	Hold time, data held after positive \overline{WE} edge	0			ns
t _{su(WE-LD)}	Setup time, positive \overline{WE} edge before \overline{LDAC} low	0			ns
t _{wh(WE)}	Pulse width, \overline{WE} high	25			ns
t _{w(LD)}	Pulse width, \overline{LDAC} low	25			ns

PARAMETER MEASUREMENT INFORMATION

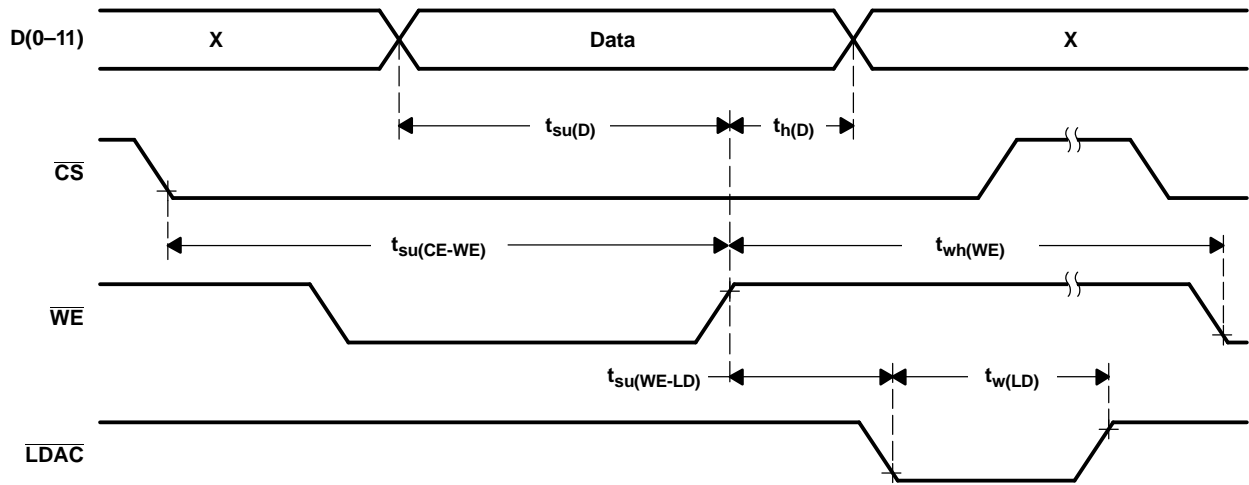

Figure 1. Timing Diagram

TYPICAL CHARACTERISTICS

**MAXIMUM OUTPUT VOLTAGE
vs
LOAD**

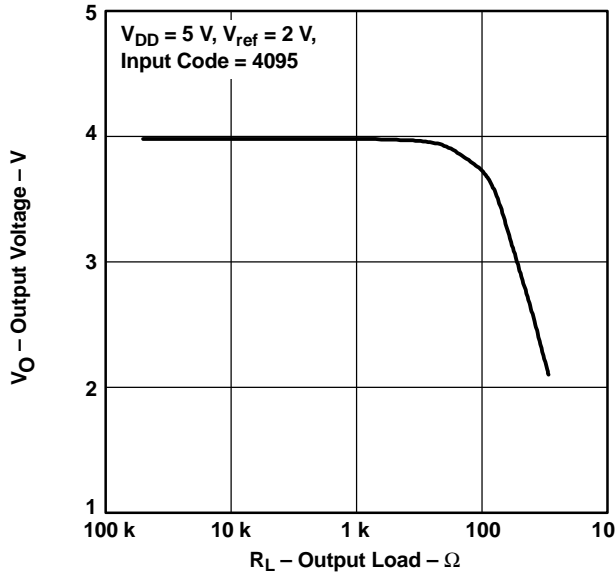

Figure 2.

**MAXIMUM OUTPUT VOLTAGE
vs
LOAD**

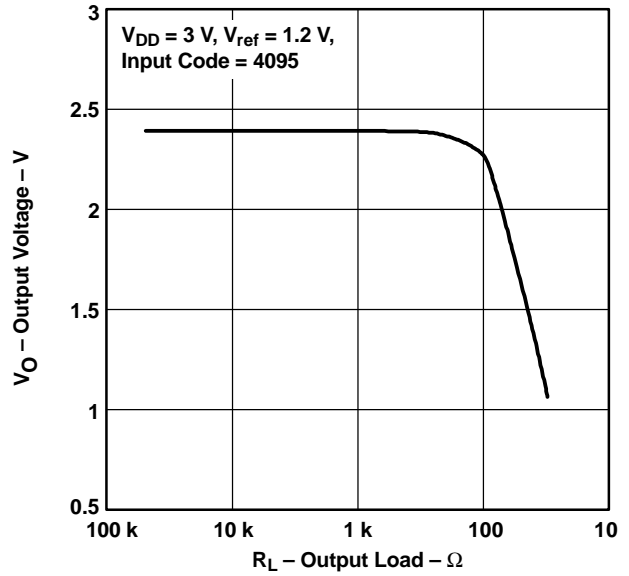

Figure 3.

**TOTAL HARMONIC DISTORTION
vs
LOAD**

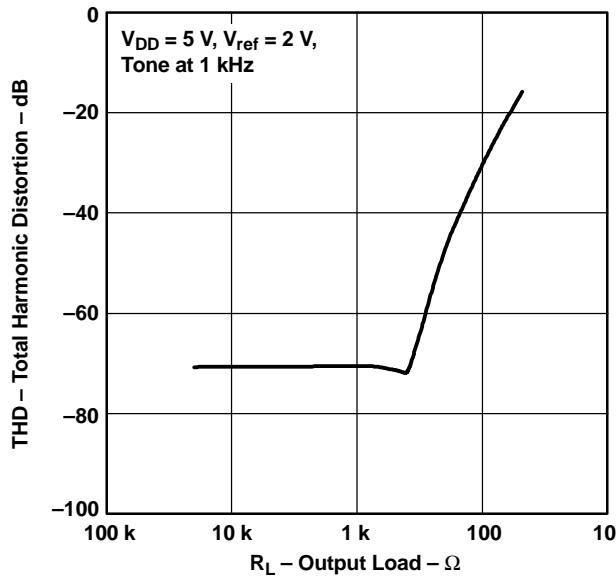

Figure 4.

**TOTAL HARMONIC DISTORTION
vs
FREQUENCY**

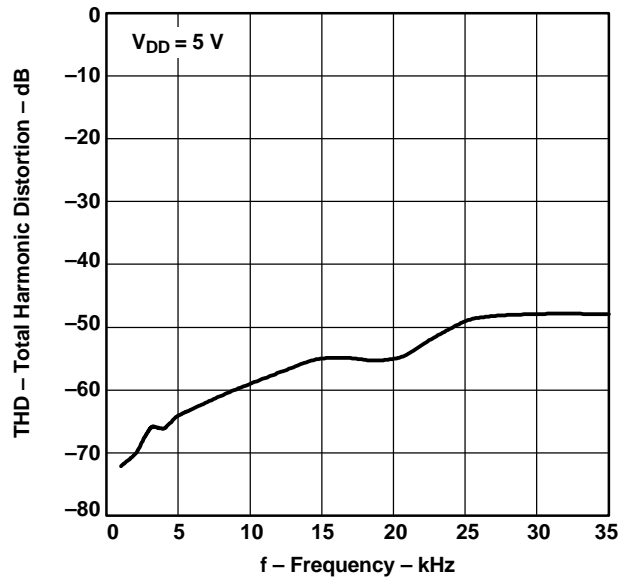

Figure 5.

TYPICAL CHARACTERISTICS (continued)

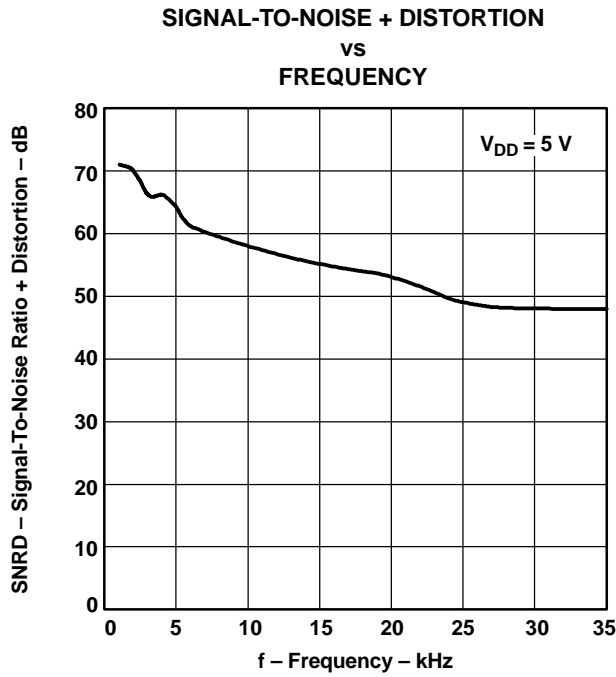

Figure 6.

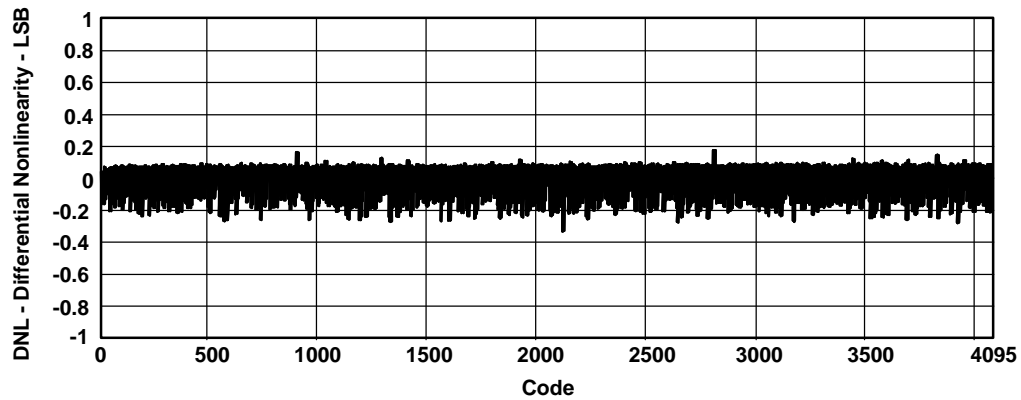

Figure 7. Differential Nonlinearity

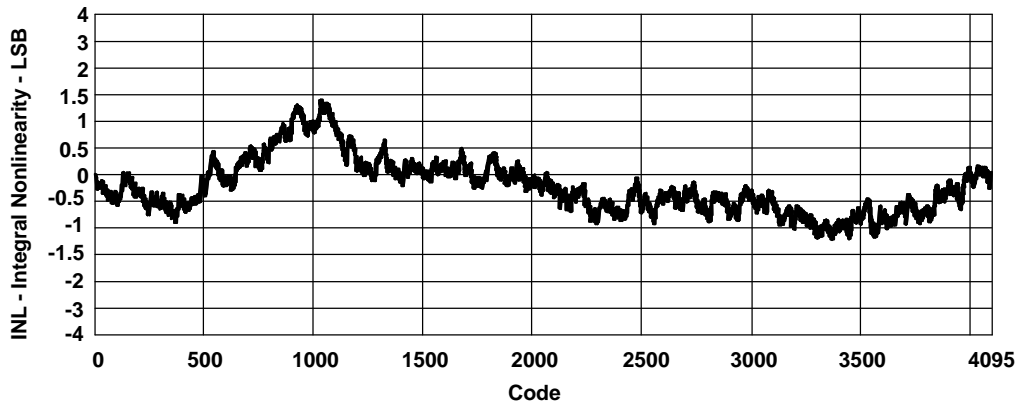

Figure 8. Integral Nonlinearity

TYPICAL CHARACTERISTICS (continued)

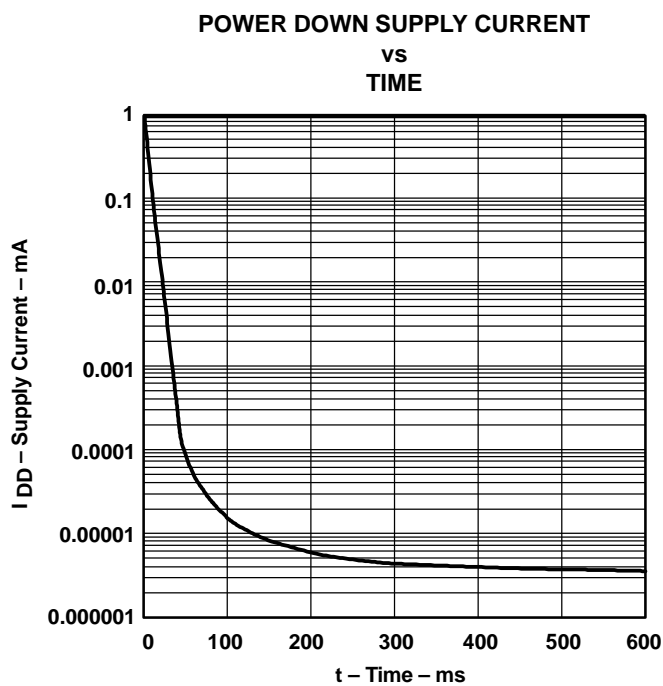

Figure 9.

APPLICATION INFORMATION**DEFINITIONS OF SPECIFICATIONS AND TERMINOLOGY****Integral Nonlinearity (INL)**

The relative accuracy or integral nonlinearity (INL), sometimes referred to as linearity error, is the maximum deviation of the output from the line between zero and full scale excluding the effects of zero code and full-scale errors.

Differential Nonlinearity (DNL)

The differential nonlinearity (DNL), sometimes referred to as differential error, is the difference between the measured and ideal 1 LSB amplitude change of any two adjacent codes. Monotonic means the output voltage changes in the same direction (or remains constant) as a change in the digital input code.

Zero-Scale Error (E_{ZS})

Zero-scale error is defined as the deviation of the output from 0 V at a digital input value of 0.

Gain Error (E_G)

Gain error is the error in slope of the DAC transfer function.

Signal-to-Noise Ratio + Distortion (S/N+D)

S/N+D is the ratio of the rms value of the output signal to the rms sum of all other spectral components below the Nyquist frequency, including harmonics but excluding dc. The value for S/N+D is expressed in decibels.

Spurious Free Dynamic Range (SFDR)

SFDR is the difference between the rms value of the output signal and the rms value of the largest spurious signal within a specified bandwidth. The value for SFDR is expressed in decibels.

Total Harmonic Distortion (THD)

THD is the ratio of the rms sum of the first six harmonic components to the rms value of the fundamental signal and is expressed in decibels.

APPLICATION INFORMATION (continued)

LINEARITY, OFFSET, AND GAIN ERROR USING SINGLE END SUPPLIES

When an amplifier is operated from a single supply, the voltage offset can still be either positive or negative. With a positive offset, the output voltage changes on the first code change. With a negative offset the output voltage may not change with the first code depending on the magnitude of the offset voltage.

The output amplifier attempts to drive the output to a negative voltage. However, because the most negative supply rail is ground, the output cannot drive below ground and clamps the output at 0 V.

The output voltage remains at zero until the input code value produces a sufficient positive output voltage to overcome the negative offset voltage, resulting in the transfer function shown in Figure 10.

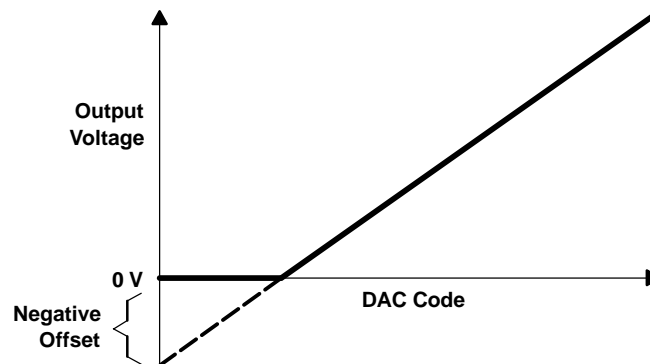

Figure 10. Effect of Negative Offset (Single Supply)

This offset error, not the linearity error, produces this breakpoint. The transfer function would have followed the dotted line if the output buffer could drive below the ground rail.

For a DAC, linearity is measured between zero input code (all inputs 0) and full scale code (all inputs 1) after offset and full scale are adjusted out or accounted for in some way. However, single supply operation does not allow for adjustment when the offset is negative due to the breakpoint in the transfer function. So the linearity is measured between full scale code and the lowest code that produces a positive output voltage.

GENERAL FUNCTION

The TLV5619 is a 12-bit, single supply DAC, based on a resistor string architecture. It consists of a parallel interface, a power down control logic, a resistor string, and a rail-to-rail output buffer. The output voltage (full scale determined by reference) is given by:

$$2 \text{ REF } \frac{\text{CODE}}{0x1000} \text{ [V]}$$

Where REF is the reference voltage and CODE is the digital input value, range 0x000 to 0xFFF. A power on reset initially puts the internal latches to a defined state (all bits zero).

APPLICATION INFORMATION (continued)

PARALLEL INTERFACE

The device latches data on the positive edge of \overline{WE} . It must be enabled with \overline{CS} low. \overline{LDAC} low updates the DAC with the value in the holding latch. \overline{LDAC} is an asynchronous input and can be held low, if a separate update is not necessary. However, to control the DAC using the load feature, \overline{LDAC} can be driven low after the positive \overline{WE} edge.

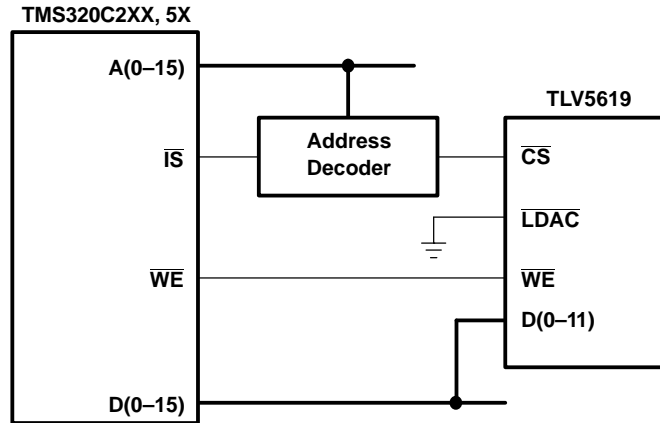

Figure 11. Proposed Interface Between TLV5619 and TMS320C2XX, 5X DSPs

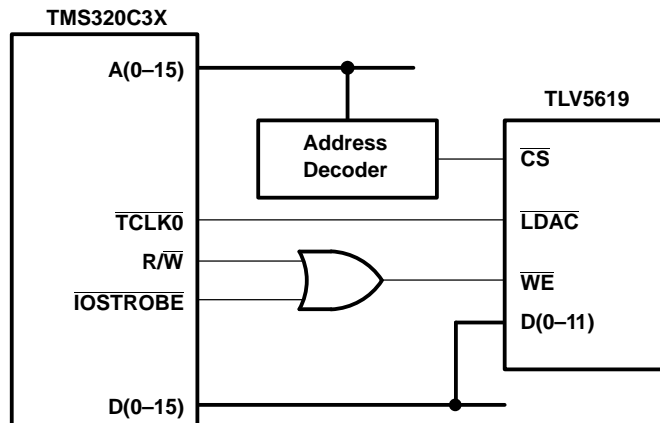

Figure 12. Proposed Interface Between TLV5619 and TMS320C3X DSPs

APPLICATION INFORMATION (continued)

TLV5619 INTERFACED TO TMS320C203 DSP

Hardware Interface

Figure 13 shows an example of the connection between the TLV5619 and the TMS320C203 DSP. The only other device that is needed in addition to the DSP and the DAC is the 74AC138 address decoding circuit. Using this configuration, the DAC address is 0x0084 within the I/O memory space of the TMS320C203.

$\overline{\text{LDAC}}$ is held low so that the output voltage is updated with the rising $\overline{\text{WE}}$ edge. The power down mode is deactivated permanently by pulling $\overline{\text{PD}}$ to V_{DD} .

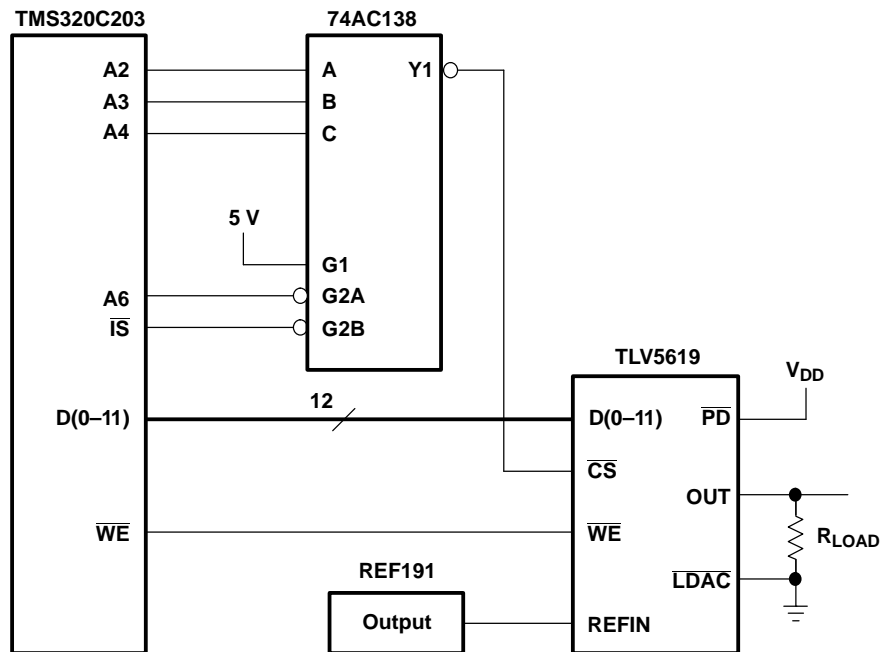

Figure 13. TLV5619 to TMS320C203 DSP Interface Connection

Software

No setup procedure is needed to access the TLV5619. The output voltage can be set using one command:

```
out data_addr, DAC_addr
```

Where `data_addr` points to the address location (in this example 0x0060) holding the new output voltage data and `DAC_addr` is the I/O space address of the TLV5619 (in this example 0x0084).

The following code shows, how to use the timer of the TMS320C203 as a time base to generate a voltage ramp with the TLV5619. A timer interrupt is generated every 205 μs . The corresponding interrupt service routine increments the output code (stored at 0x0060) for the DAC and writes the new code to the TLV5619. Only the 12 LSBs of the data in 0x0060 are used by the DAC, so that the resulting period of the saw waveform is:

- $t = 4096 \times 205 \text{ E-6 s} = 0.84 \text{ s}$

APPLICATION INFORMATION (continued)**SOFTWARE LISTING**

```

; File: ramp.asm
; Description: This program generates a ramp.

;----- I/O and memory mapped regs -----
                .include "regs.asm"
TLV5619        .equ    0084h
;----- vectors -----
                .ps     0h
                b       start
                b       INT1
                b       INT23
                b       TIM_ISR

*****
* Main Program
*****

                .ps     1000h
                .entry

start:
                ldp     #0      ; set data page to 0
; disable interrupts
                setc   INTM    ; disable maskable interrupts
                splk   #0ffffh, IFR
                splk   #0004h,  IMR

; set up the timer
                splk   #0000h,   60h
                splk   #0042h,   61h
                out    61h, PRD
                out    60h, TIM
                splk   #0c2fh,   62h
                out    62h, TCR

; enable interrupts
                clrc   INTM    ; enable maskable interrupts

; loop forever!
next           idle      ; wait for interrupt
                b      next
; all else fails stop here
done           b      done ; hang there

*****
* Interrupt Service Routines
*****

INT1:          ret        ; do nothing and return

INT23:         ret        ; do nothing and return

TIM_ISR:
                ; useful code
                add    #1h ; increment accumulator
                sacl   60h

```

APPLICATION INFORMATION (continued)

```
out      60h, TLV5619 ; write to DAC
clrc     intm; re-enable interrupts
ret      ; return from interrupt
.end
```

PACKAGING INFORMATION

Orderable Device	Status ⁽¹⁾	Package Type	Package Drawing	Pins	Package Qty	Eco Plan ⁽²⁾	Lead/Ball Finish	MSL Peak Temp ⁽³⁾
TLV5619CDW	ACTIVE	SOIC	DW	20	25	Green (RoHS & no Sb/Br)	CU NIPDAU	Level-1-260C-UNLIM
TLV5619CDWG4	ACTIVE	SOIC	DW	20	25	Green (RoHS & no Sb/Br)	CU NIPDAU	Level-1-260C-UNLIM
TLV5619CDWR	ACTIVE	SOIC	DW	20	2000	Green (RoHS & no Sb/Br)	CU NIPDAU	Level-1-260C-UNLIM
TLV5619CDWRG4	ACTIVE	SOIC	DW	20	2000	Green (RoHS & no Sb/Br)	CU NIPDAU	Level-1-260C-UNLIM
TLV5619CPW	ACTIVE	TSSOP	PW	20	70	Green (RoHS & no Sb/Br)	CU NIPDAU	Level-1-260C-UNLIM
TLV5619CPWG4	ACTIVE	TSSOP	PW	20	70	Green (RoHS & no Sb/Br)	CU NIPDAU	Level-1-260C-UNLIM
TLV5619CPWR	ACTIVE	TSSOP	PW	20	2000	Green (RoHS & no Sb/Br)	CU NIPDAU	Level-1-260C-UNLIM
TLV5619CPWRG4	ACTIVE	TSSOP	PW	20	2000	Green (RoHS & no Sb/Br)	CU NIPDAU	Level-1-260C-UNLIM
TLV5619IDW	ACTIVE	SOIC	DW	20	25	Green (RoHS & no Sb/Br)	CU NIPDAU	Level-1-260C-UNLIM
TLV5619IDWG4	ACTIVE	SOIC	DW	20	25	Green (RoHS & no Sb/Br)	CU NIPDAU	Level-1-260C-UNLIM
TLV5619IDWR	ACTIVE	SOIC	DW	20	2000	Green (RoHS & no Sb/Br)	CU NIPDAU	Level-1-260C-UNLIM
TLV5619IDWRG4	ACTIVE	SOIC	DW	20	2000	Green (RoHS & no Sb/Br)	CU NIPDAU	Level-1-260C-UNLIM
TLV5619IPW	ACTIVE	TSSOP	PW	20	70	Green (RoHS & no Sb/Br)	CU NIPDAU	Level-1-260C-UNLIM
TLV5619IPWG4	ACTIVE	TSSOP	PW	20	70	Green (RoHS & no Sb/Br)	CU NIPDAU	Level-1-260C-UNLIM
TLV5619IPWR	ACTIVE	TSSOP	PW	20	2000	Green (RoHS & no Sb/Br)	CU NIPDAU	Level-1-260C-UNLIM
TLV5619IPWRG4	ACTIVE	TSSOP	PW	20	2000	Green (RoHS & no Sb/Br)	CU NIPDAU	Level-1-260C-UNLIM
TLV5619QDW	ACTIVE	SOIC	DW	20	25	TBD	CU NIPDAU	Level-1-220C-UNLIM
TLV5619QDWG4	ACTIVE	SOIC	DW	20	25	Green (RoHS & no Sb/Br)	CU NIPDAU	Level-1-260C-UNLIM
TLV5619QDWR	ACTIVE	SOIC	DW	20	2000	TBD	CU NIPDAU	Level-1-220C-UNLIM
TLV5619QDWRG4	ACTIVE	SOIC	DW	20	2000	Green (RoHS & no Sb/Br)	CU NIPDAU	Level-1-260C-UNLIM

⁽¹⁾ The marketing status values are defined as follows:

ACTIVE: Product device recommended for new designs.

LIFEBUY: TI has announced that the device will be discontinued, and a lifetime-buy period is in effect.

NRND: Not recommended for new designs. Device is in production to support existing customers, but TI does not recommend using this part in a new design.

PREVIEW: Device has been announced but is not in production. Samples may or may not be available.

OBsolete: TI has discontinued the production of the device.

⁽²⁾ Eco Plan - The planned eco-friendly classification: Pb-Free (RoHS), Pb-Free (RoHS Exempt), or Green (RoHS & no Sb/Br) - please check <http://www.ti.com/productcontent> for the latest availability information and additional product content details.

TBD: The Pb-Free/Green conversion plan has not been defined.

Pb-Free (RoHS): TI's terms "Lead-Free" or "Pb-Free" mean semiconductor products that are compatible with the current RoHS requirements

for all 6 substances, including the requirement that lead not exceed 0.1% by weight in homogeneous materials. Where designed to be soldered at high temperatures, TI Pb-Free products are suitable for use in specified lead-free processes.

Pb-Free (RoHS Exempt): This component has a RoHS exemption for either 1) lead-based flip-chip solder bumps used between the die and package, or 2) lead-based die adhesive used between the die and leadframe. The component is otherwise considered Pb-Free (RoHS compatible) as defined above.

Green (RoHS & no Sb/Br): TI defines "Green" to mean Pb-Free (RoHS compatible), and free of Bromine (Br) and Antimony (Sb) based flame retardants (Br or Sb do not exceed 0.1% by weight in homogeneous material)

(3) MSL, Peak Temp. -- The Moisture Sensitivity Level rating according to the JEDEC industry standard classifications, and peak solder temperature.

Important Information and Disclaimer:The information provided on this page represents TI's knowledge and belief as of the date that it is provided. TI bases its knowledge and belief on information provided by third parties, and makes no representation or warranty as to the accuracy of such information. Efforts are underway to better integrate information from third parties. TI has taken and continues to take reasonable steps to provide representative and accurate information but may not have conducted destructive testing or chemical analysis on incoming materials and chemicals. TI and TI suppliers consider certain information to be proprietary, and thus CAS numbers and other limited information may not be available for release.

In no event shall TI's liability arising out of such information exceed the total purchase price of the TI part(s) at issue in this document sold by TI to Customer on an annual basis.

OTHER QUALIFIED VERSIONS OF TLV5619 :

- Enhanced Product: [TLV5619-EP](#)

NOTE: Qualified Version Definitions:

- Enhanced Product - Supports Defense, Aerospace and Medical Applications

TAPE AND REEL INFORMATION

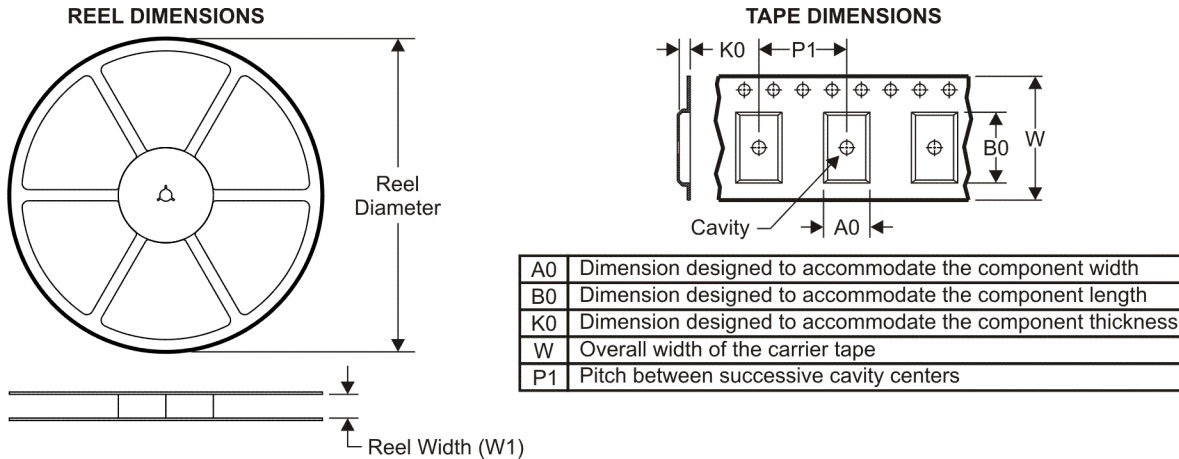

QUADRANT ASSIGNMENTS FOR PIN 1 ORIENTATION IN TAPE

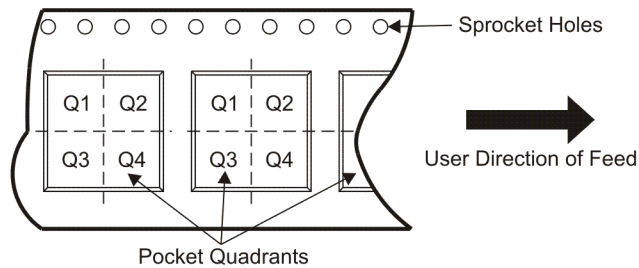

*All dimensions are nominal

Device	Package Type	Package Drawing	Pins	SPQ	Reel Diameter (mm)	Reel Width W1 (mm)	A0 (mm)	B0 (mm)	K0 (mm)	P1 (mm)	W (mm)	Pin1 Quadrant
TLV5619CPWR	TSSOP	PW	20	2000	330.0	16.4	6.95	7.1	1.6	8.0	16.0	Q1
TLV5619IPWR	TSSOP	PW	20	2000	330.0	16.4	6.95	7.1	1.6	8.0	16.0	Q1

TAPE AND REEL BOX DIMENSIONS

*All dimensions are nominal

Device	Package Type	Package Drawing	Pins	SPQ	Length (mm)	Width (mm)	Height (mm)
TLV5619CPWR	TSSOP	PW	20	2000	346.0	346.0	33.0
TLV5619IPWR	TSSOP	PW	20	2000	346.0	346.0	33.0

PW (R-PDSO-G**)

PLASTIC SMALL-OUTLINE PACKAGE

14 PINS SHOWN



4040064/F 01/97

- NOTES: A. All linear dimensions are in millimeters.
 B. This drawing is subject to change without notice.
 C. Body dimensions do not include mold flash or protrusion not to exceed 0,15.
 D. Falls within JEDEC MO-153

DW (R-PDSO-G20)

PLASTIC SMALL-OUTLINE PACKAGE

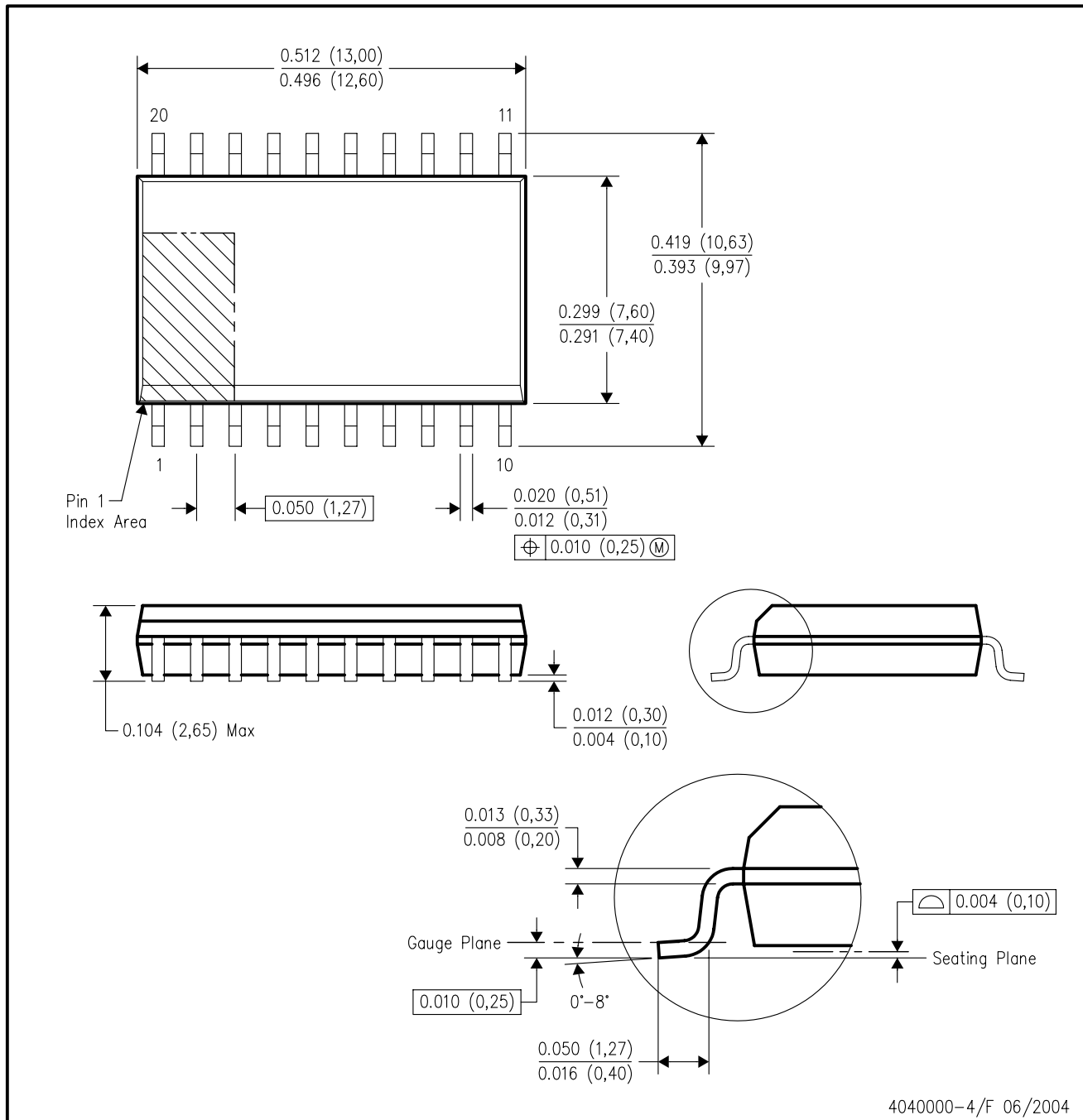

- NOTES:
- A. All linear dimensions are in inches (millimeters).
 - B. This drawing is subject to change without notice.
 - C. Body dimensions do not include mold flash or protrusion not to exceed 0.006 (0,15).
 - D. Falls within JEDEC MS-013 variation AC.

IMPORTANT NOTICE

Texas Instruments Incorporated and its subsidiaries (TI) reserve the right to make corrections, modifications, enhancements, improvements, and other changes to its products and services at any time and to discontinue any product or service without notice. Customers should obtain the latest relevant information before placing orders and should verify that such information is current and complete. All products are sold subject to TI's terms and conditions of sale supplied at the time of order acknowledgment.

TI warrants performance of its hardware products to the specifications applicable at the time of sale in accordance with TI's standard warranty. Testing and other quality control techniques are used to the extent TI deems necessary to support this warranty. Except where mandated by government requirements, testing of all parameters of each product is not necessarily performed.

TI assumes no liability for applications assistance or customer product design. Customers are responsible for their products and applications using TI components. To minimize the risks associated with customer products and applications, customers should provide adequate design and operating safeguards.

TI does not warrant or represent that any license, either express or implied, is granted under any TI patent right, copyright, mask work right, or other TI intellectual property right relating to any combination, machine, or process in which TI products or services are used. Information published by TI regarding third-party products or services does not constitute a license from TI to use such products or services or a warranty or endorsement thereof. Use of such information may require a license from a third party under the patents or other intellectual property of the third party, or a license from TI under the patents or other intellectual property of TI.

Reproduction of TI information in TI data books or data sheets is permissible only if reproduction is without alteration and is accompanied by all associated warranties, conditions, limitations, and notices. Reproduction of this information with alteration is an unfair and deceptive business practice. TI is not responsible or liable for such altered documentation. Information of third parties may be subject to additional restrictions.

Resale of TI products or services with statements different from or beyond the parameters stated by TI for that product or service voids all express and any implied warranties for the associated TI product or service and is an unfair and deceptive business practice. TI is not responsible or liable for any such statements.

TI products are not authorized for use in safety-critical applications (such as life support) where a failure of the TI product would reasonably be expected to cause severe personal injury or death, unless officers of the parties have executed an agreement specifically governing such use. Buyers represent that they have all necessary expertise in the safety and regulatory ramifications of their applications, and acknowledge and agree that they are solely responsible for all legal, regulatory and safety-related requirements concerning their products and any use of TI products in such safety-critical applications, notwithstanding any applications-related information or support that may be provided by TI. Further, Buyers must fully indemnify TI and its representatives against any damages arising out of the use of TI products in such safety-critical applications.

TI products are neither designed nor intended for use in military/aerospace applications or environments unless the TI products are specifically designated by TI as military-grade or "enhanced plastic." Only products designated by TI as military-grade meet military specifications. Buyers acknowledge and agree that any such use of TI products which TI has not designated as military-grade is solely at the Buyer's risk, and that they are solely responsible for compliance with all legal and regulatory requirements in connection with such use.

TI products are neither designed nor intended for use in automotive applications or environments unless the specific TI products are designated by TI as compliant with ISO/TS 16949 requirements. Buyers acknowledge and agree that, if they use any non-designated products in automotive applications, TI will not be responsible for any failure to meet such requirements.

Following are URLs where you can obtain information on other Texas Instruments products and application solutions:

Products

Amplifiers	amplifier.ti.com
Data Converters	dataconverter.ti.com
DLP® Products	www.dlp.com
DSP	dsp.ti.com
Clocks and Timers	www.ti.com/clocks
Interface	interface.ti.com
Logic	logic.ti.com
Power Mgmt	power.ti.com
Microcontrollers	microcontroller.ti.com
RFID	www.ti-rfid.com
RF/IF and ZigBee® Solutions	www.ti.com/lprf

Applications

Audio	www.ti.com/audio
Automotive	www.ti.com/automotive
Broadband	www.ti.com/broadband
Digital Control	www.ti.com/digitalcontrol
Medical	www.ti.com/medical
Military	www.ti.com/military
Optical Networking	www.ti.com/opticalnetwork
Security	www.ti.com/security
Telephony	www.ti.com/telephony
Video & Imaging	www.ti.com/video
Wireless	www.ti.com/wireless

Mailing Address: Texas Instruments, Post Office Box 655303, Dallas, Texas 75265
Copyright © 2009, Texas Instruments Incorporated