

2.7-V TO 5.5-V LOW-POWER 12-BIT DIGITAL-TO-ANALOG CONVERTERS WITH INTERNAL REFERENCE AND POWER DOWN

FEATURES

- 12-Bit Voltage Output DAC
- Programmable Internal Reference
- Programmable Settling Time vs Power Consumption
 - 1 μ s in Fast Mode
 - 3.5 μ s in Slow Mode
- Compatible With TMS320
- Differential Nonlinearity . . . <0.5 LSB Typ
- Voltage Output Range . . . 2x the Reference Voltage
- Monotonic Over Temperature

DW OR PW PACKAGE
(TOP VIEW)

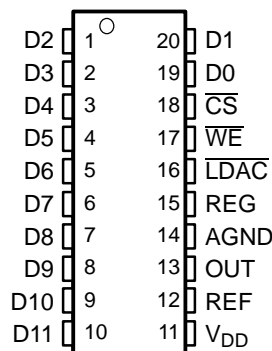

APPLICATIONS

- Digital Servo Control Loops
- Digital Offset and Gain Adjustment
- Industrial Process Control
- Machine and Motion Control Devices
- Mass Storage Devices

DESCRIPTION

The TLV5639 is a 12-bit voltage output digital-to-analog converter (DAC) with a microprocessor compatible parallel interface. It is programmed with a 16-bit data word containing 4 control and 12 data bits. Developed for a wide range of supply voltages, the TLV5639 can be operated from 2.7 V to 5.5 V.

The resistor string output voltage is buffered by a x2 gain rail-to-rail output buffer. The buffer features a Class AB output stage to improve stability and reduce settling time. The programmable settling time of the DAC allows the designer to optimize speed versus power dissipation. Because of its ability to source up to 1 mA, the internal reference can also be used as a system reference. With its on-chip programmable precision voltage reference, the TLV5639 simplifies overall system design. The settling time and the reference voltage can be chosen by the control bits within the 16-bit data word.

Implemented with a CMOS process, the device is designed for single supply operation from 2.7 V to 5.5 V. It is available in 20-pin SOIC and TSSOP packages in standard commercial and industrial temperature ranges.

AVAILABLE OPTIONS

| T _A | PACKAGE | |
|----------------|------------|------------|
| | SOIC (DW) | TSSOP (PW) |
| 0°C to 70°C | TLV5639CDW | TLV5639CPW |
| -40°C to 85°C | TLV5639IDW | TLV5639IPW |



Please be aware that an important notice concerning availability, standard warranty, and use in critical applications of Texas Instruments semiconductor products and disclaimers thereto appears at the end of this data sheet.



These devices have limited built-in ESD protection. The leads should be shorted together or the device placed in conductive foam during storage or handling to prevent electrostatic damage to the MOS gates.

FUNCTIONAL BLOCK DIAGRAM

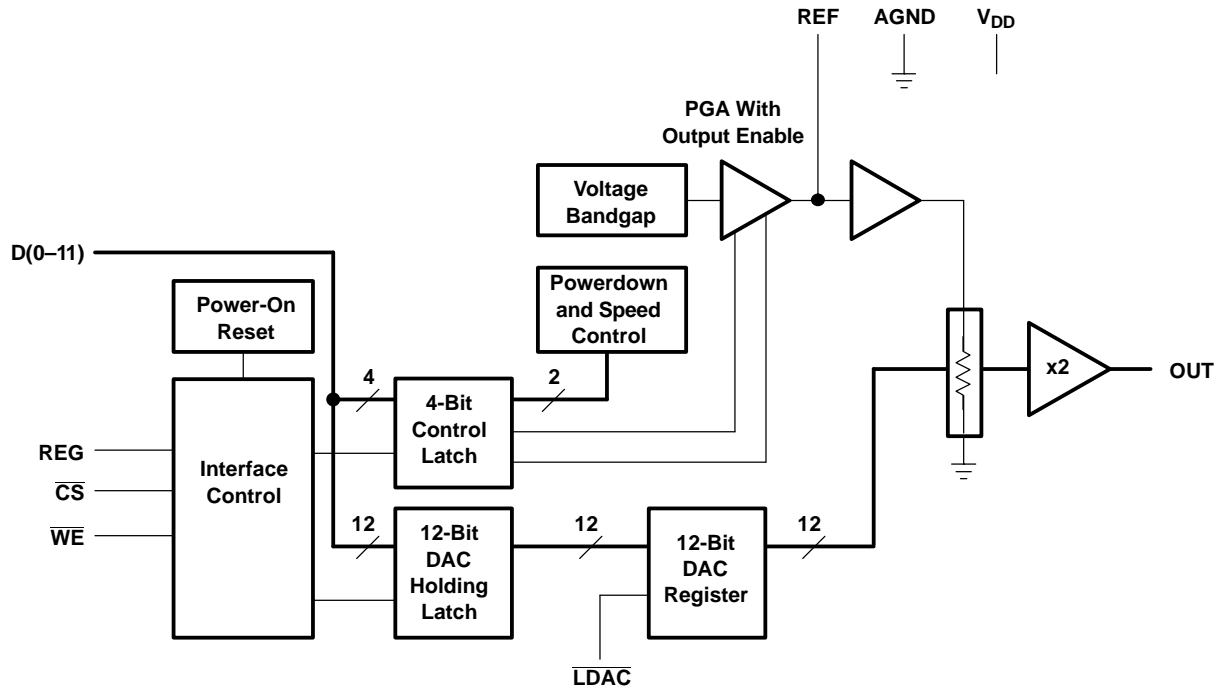

Terminal Functions

| TERMINAL NAME | NO. | I/O/P | DESCRIPTION |
|-------------------|--------------|-------|--|
| AGND | 14 | P | Ground |
| \overline{CS} | 18 | I | Chip select. Digital input active low, used to enable/disable inputs |
| D0-D11 | 1-10, 19, 20 | I | Data input |
| \overline{LDAC} | 16 | I | Load DAC. Digital input active low, used to load DAC output |
| OUT | 13 | O | DAC analog voltage output |
| REG | 15 | I | Register select. Digital input, used to access control register |
| REF | 12 | I/O | Analog reference voltage input/output |
| V_{DD} | 11 | P | Positive power supply |
| \overline{WE} | 17 | I | Write enable. Digital input active low, used to latch data |

ABSOLUTE MAXIMUM RATINGS

over operating free-air temperature range (unless otherwise noted) ⁽¹⁾

| | | UNIT |
|--|----------|-----------------------------|
| Supply voltage (V_{DD} to AGND) | | 7 V |
| Reference input voltage range | | - 0.3 V to $V_{DD} + 0.3$ V |
| Digital input voltage range | | - 0.3 V to $V_{DD} + 0.3$ V |
| Operating free-air temperature range, T_A | TLV5639C | 0°C to 70°C |
| | TLV5639I | -40°C to 85°C |
| Storage temperature range, T_{stg} | | -65°C to 150°C |
| Lead temperature 1,6 mm (1/16 inch) from case for 10 seconds | | 260°C |

(1) Stresses beyond those listed under *absolute maximum ratings* may cause permanent damage to the device. These are stress ratings only, and functional operation of the device at these or any other conditions beyond those indicated under *recommended operating conditions* is not implied. Exposure to absolute-maximum-rated conditions for extended periods may affect device reliability.

RECOMMENDED OPERATING CONDITIONS

| | | MIN | NOM | MAX | UNIT |
|--|-------------------------------|------|-------|--------------|------------|
| Supply voltage, V_{DD} | $V_{DD} = 5$ V | 4.5 | 5 | 5.5 | V |
| | $V_{DD} = 3$ V | 2.7 | 3 | 3.3 | V |
| Power on threshold voltage, POR | | 0.55 | | 2 | V |
| High-level digital input voltage, V_{IH} | $V_{DD} = 2.7$ V | 2 | | | V |
| | $V_{DD} = 5.5$ V | 2.4 | | | |
| Low-level digital input voltage, V_{IL} | $V_{DD} = 2.7$ V | | | 0.6 | V |
| | $V_{DD} = 5.5$ V | | | 1 | |
| Reference voltage, V_{ref} to REF terminal | $V_{DD} = 5$ V ⁽¹⁾ | AGND | 2.048 | $V_{DD}-1.5$ | V |
| Reference voltage, V_{ref} to REF terminal | $V_{DD} = 3$ V ⁽¹⁾ | AGND | 1.024 | $V_{DD}-1.5$ | V |
| Load resistance, R_L | | 2 | | | k Ω |
| Load capacitance, C_L | | | | 100 | pF |
| Operating free-air temperature, T_A | TLV5639C | 0 | | 70 | °C |
| | TLV5639I | 40 | | 85 | |

(1) Due to the x2 output buffer, a reference input voltage $\geq V_{DD}/2$ causes clipping of the transfer function. The output buffer of the internal reference must be disabled, if an external reference is used.

ELECTRICAL CHARACTERISTICS

over operating free-air temperature range (unless otherwise noted)

| POWER SUPPLY | | | | | | | | | |
|---------------------------|------------------------------|---|-----------------------|-----------------------|--------|------|-----|------|----|
| PARAMETER | | TEST CONDITIONS | | | MIN | TYP | MAX | UNIT | |
| I _{DD} | Power supply current | No load, All inputs = AGND or V _{DD} , DAC latch = 0x800 | V _{DD} = 5 V | REF on | Fast | 2.3 | 2.8 | mA | |
| | | | | | Slow | 1.3 | 1.6 | mA | |
| | | | | REF off | Fast | 1.9 | 2.4 | mA | |
| | | | | | Slow | 0.9 | 1.2 | mA | |
| | | | | V _{DD} = 3 V | REF on | Fast | 2.1 | 2.6 | mA |
| | | | | | Slow | 1.2 | 1.5 | mA | |
| | | | REF off | | Fast | 1.8 | 2.3 | mA | |
| | | | | | Slow | 0.9 | 1.1 | mA | |
| Power down supply current | | | | | 0.01 | 1 | μA | | |
| PSRR | Power supply rejection ratio | Zero scale, External reference ⁽¹⁾ | | | | 60 | | dB | |
| | | Full scale, External reference ⁽²⁾ | | | | 60 | | | |

(1) Power supply rejection ratio at zero scale is measured by varying V_{DD} and is given by:

$$PSRR = 20 \log [(E_{ZS}(V_{DDmax}) - E_{ZS}(V_{DDmin})) / V_{DDmax}]$$

(2) Power supply rejection ratio at full scale is measured by varying V_{DD} and is given by:

$$PSRR = 20 \log [(E_G(V_{DDmax}) - E_G(V_{DDmin})) / V_{DDmax}]$$

| STATIC DAC SPECIFICATIONS | | | | | | | | |
|---------------------------|---|--|--|--|-----|------|------|----------------|
| PARAMETER | | TEST CONDITIONS | | | MIN | TYP | MAX | UNIT |
| Resolution | | | | | | 12 | | bits |
| INL | Integral nonlinearity, end point adjusted | R _L = 10 kΩ, C _L = 100 pF, See note ⁽¹⁾ | | | | ±1.2 | ±3 | LSB |
| DNL | Differential nonlinearity | R _L = 10 kΩ, C _L = 100 pF, See note ⁽²⁾ | | | | ±0.3 | ±0.5 | LSB |
| E _{ZS} | Zero-scale error (offset error at zero scale) | See note ⁽³⁾ | | | | | ±12 | LSB |
| E _{ZS} TC | Zero-scale-error temperature coefficient | See note ⁽⁴⁾ | | | | 20 | | ppm/°C |
| E _G | Gain error | See note ⁽⁵⁾ | | | | | ±0.3 | % full scale V |
| E _G TC | Gain error temperature coefficient | See note ⁽⁶⁾ | | | | 20 | | ppm/°C |

(1) The relative accuracy or integral nonlinearity (INL) sometimes referred to as linearity error, is the maximum deviation of the output from the line between zero and full scale excluding the effects of zero code and full-scale errors (see text).

(2) The differential nonlinearity (DNL) sometimes referred to as differential error, is the difference between the measured and ideal 1 LSB amplitude change of any two adjacent codes. Monotonic means the output voltage changes in the same direction (or remains constant) as a change in the digital input code.

(3) Zero-scale error is the deviation from zero voltage output when the digital input code is zero (see text).

(4) Zero-scale-error temperature coefficient is given by: $E_{ZS} TC = [E_{ZS}(T_{max}) - E_{ZS}(T_{min})] / 2V_{ref} \times 10^6 / (T_{max} - T_{min})$.

(5) Gain error is the deviation from the ideal output (2V_{ref} - 1 LSB) with an output load of 10 k excluding the effects of the zero-error.

(6) Gain temperature coefficient is given by: $E_G TC = [E_G(T_{max}) - E_G(T_{min})] / 2V_{ref} \times 10^6 / (T_{max} - T_{min})$.

| OUTPUT SPECIFICATIONS | | | | | | | | |
|---------------------------------|----------------|--|--|--|-----|-----|----------------------|----------------|
| PARAMETER | | TEST CONDITIONS | | | MIN | TYP | MAX | UNIT |
| V _O | Output voltage | R _L = 10 kΩ | | | | | V _{DD} -0.4 | V |
| Output load regulation accuracy | | V _O = 4.096 V, 2.048 V, R _L = 2 kΩ | | | | | ±0.29 | % full scale V |

ELECTRICAL CHARACTERISTICS

over operating free-air temperature range (unless otherwise noted)

| REFERENCE PIN CONFIGURED AS OUTPUT (REF) | | | | | | | |
|--|------------------------------|-------------------|-------|-------|-------|-------|---|
| PARAMETER | TEST CONDITIONS | MIN | TYP | MAX | UNIT | | |
| $V_{ref(OUTL)}$ | Low reference voltage | 1.003 | 1.024 | 1.045 | V | | |
| $V_{ref(OUTH)}$ | High reference voltage | $V_{DD} > 4.75$ V | | 2.027 | 2.048 | 2.069 | V |
| $I_{ref(source)}$ | Output source current | | | | 1 | mA | |
| $I_{ref(sink)}$ | Output sink current | 1 | | | mA | | |
| PSRR | Power supply rejection ratio | 48 | | | dB | | |

| REFERENCE PIN CONFIGURED AS INPUT (REF) | | | | | | |
|---|---|-----------------------|--|-----|------------|----|
| PARAMETER | TEST CONDITIONS | MIN | TYP | MAX | UNIT | |
| V_I | Input voltage | 0 | $V_{DD} - 1.5$ | | V | |
| R_I | Input resistance | 10 | | | M Ω | |
| C_I | Input capacitance | 5 | | | pF | |
| Reference input bandwidth | REF = 0.2 V_{pp} + 1.024 V dc | Fast | 900 | | kHz | |
| | | Slow | 500 | | | |
| Harmonic distortion, reference input | REF = 1 V_{pp} + 2.048 V dc, $V_{DD} = 5$ V | 10 kHz | Fast | 87 | | dB |
| | | | Slow | 77 | | |
| | | 50 kHz | Fast | 74 | | dB |
| | | | Slow | 61 | | |
| | | 100 kHz | Fast | 66 | | dB |
| | | Reference feedthrough | REF = 1 V_{pp} at 1 kHz + 1.024 V dc, See ⁽¹⁾ | 80 | | |

(1) Reference feedthrough is measured at the DAC output with an input code = 0x000.

| DIGITAL INPUTS | | | | | | | |
|----------------|----------------------------------|----------------|-----|-----|------|---------|--|
| PARAMETER | TEST CONDITIONS | MIN | TYP | MAX | UNIT | | |
| I_{IH} | High-level digital input current | $V_I = V_{DD}$ | | | 1 | μ A | |
| I_{IL} | Low-level digital input current | $V_I = 0$ V | | | 1 | μ A | |
| C_i | Input capacitance | | | | 8 | pF | |

OPERATING CHARACTERISTICS

over recommended operating free-air temperature range, $V_{ref} = 2.048\text{ V}$, and $V_{ref} = 1.024\text{ V}$, (unless otherwise noted)

| ANALOG OUTPUT DYNAMIC PERFORMANCE | | | | | | | | |
|-----------------------------------|------------------------------------|---|---|-----|-----|-----|--------------------------|----|
| PARAMETER | | TEST CONDITIONS | | MIN | TYP | MAX | UNIT | |
| $t_{s(FS)}$ | Output settling time, full scale | $R_L = 10\text{ k}\Omega$, $C_L = 100\text{ pF}$, see note (1) | Fast | | 1 | 3 | μs | |
| | | | Slow | | 3.5 | 7 | | |
| $t_{s(CC)}$ | Output settling time, code to code | $R_L = 10\text{ k}\Omega$, $C_L = 100\text{ pF}$, see note (2) | Fast | | 0.5 | 1.5 | μs | |
| | | | Slow | | 1 | 2 | | |
| SR | Slew rate | $R_L = 10\text{ k}\Omega$, $C_L = 100\text{ pF}$, see note (3) | Fast | 6 | 10 | | $\text{V}/\mu\text{s}$ | |
| | | | Slow | 1.2 | 1.7 | | | |
| | Glitch energy | $\text{DIN} = 0\text{ to }1$, $f_{CLK} = 100\text{ kHz}$, $\overline{\text{CS}} = V_{DD}$ | | | 5 | | $\text{nV}\cdot\text{S}$ | |
| SNR | Signal-to-noise ratio | $f_s = 480\text{ kSPS}$, $f_B = 20\text{ kHz}$, $C_L = 100\text{ pF}$ | $f_{out} = 1\text{ kHz}$, $R_L = 10\text{ k}\Omega$ | | 73 | 78 | dB | |
| SINAD | Signal-to-noise + distortion | | | | 61 | 67 | | |
| THD | Total harmonic distortion | | | | | 69 | | 62 |
| SFDR | Spurious free dynamic range | | | | 63 | 74 | | |

- (1) Settling time is the time for the output signal to remain within ± 0.5 LSB of the final measured value for a digital input code change of $0x020$ to $0xFDF$ or $0xFDF$ to $0x020$.
- (2) Settling time is the time for the output signal to remain within ± 0.5 LSB of the final measured value for a digital input code change of one count.
- (3) Slew rate determines the time it takes for a change of the DAC output from 10% to 90% full-scale voltage.

DIGITAL INPUT TIMING REQUIREMENTS

| | | MIN | NOM | MAX | UNIT |
|-----------------|--|-----|-----|-----|------|
| $t_{su(CS-WE)}$ | Setup time, $\overline{\text{CS}}$ low before negative $\overline{\text{WE}}$ edge | 15 | | | ns |
| $t_{su(D)}$ | Setup time, data ready before positive $\overline{\text{WE}}$ edge | 10 | | | ns |
| $t_{su(R)}$ | Setup time, REG ready before positive $\overline{\text{WE}}$ edge | 20 | | | ns |
| $t_{h(DR)}$ | Hold time, data and REG held valid after positive $\overline{\text{WE}}$ edge | 5 | | | ns |
| $t_{su(WE-LD)}$ | Setup time, positive $\overline{\text{WE}}$ edge before $\overline{\text{LDAC}}$ low | 5 | | | ns |
| $t_{wH(WE)}$ | Pulse duration, $\overline{\text{WE}}$ high | 20 | | | ns |
| $t_{w(LD)}$ | Pulse duration, $\overline{\text{LDAC}}$ low | 23 | | | ns |

PARAMETER MEASUREMENT INFORMATION

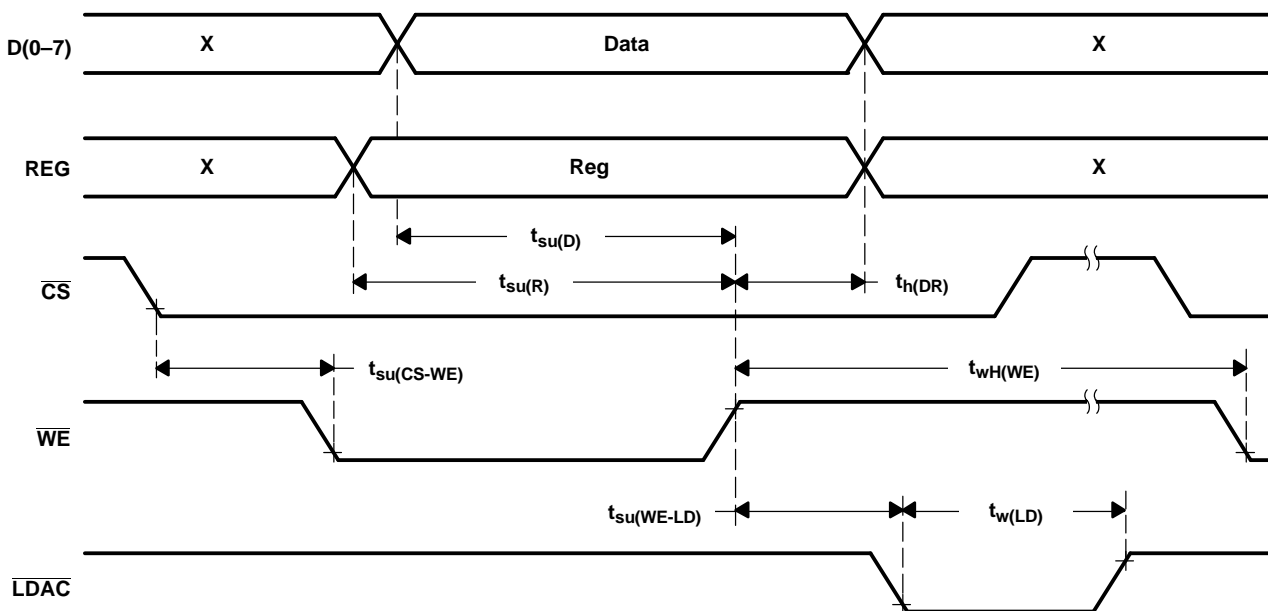

Figure 1. Timing Diagram

TYPICAL CHARACTERISTICS
DIFFERENTIAL NONLINEARITY ERROR

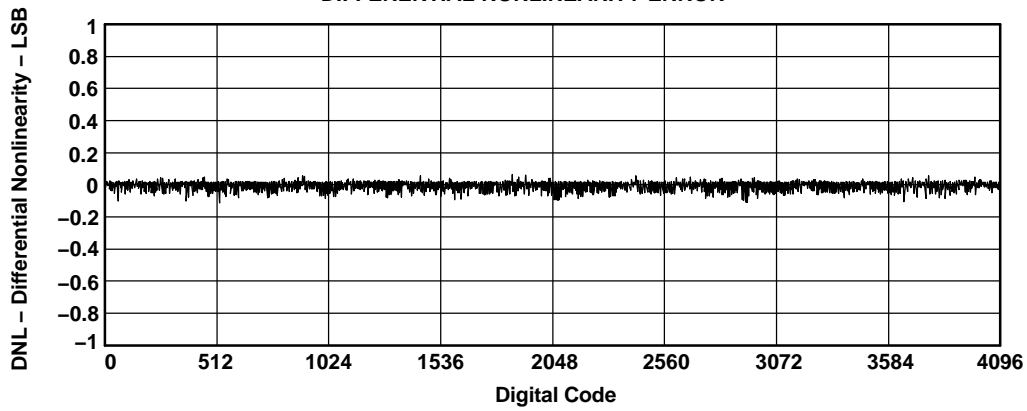

Figure 2.

INTEGRAL NONLINEARITY ERROR

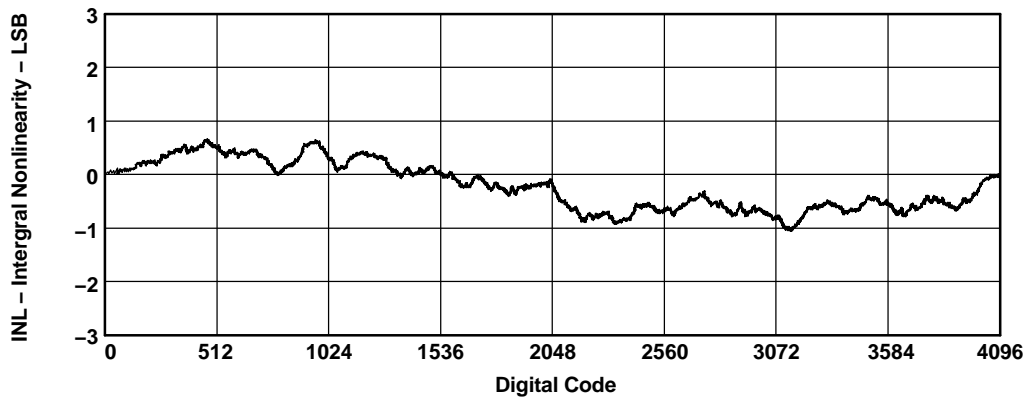

Figure 3.

TYPICAL CHARACTERISTICS (continued)

MAXIMUM OUTPUT VOLTAGE
vs
LOAD CURRENT

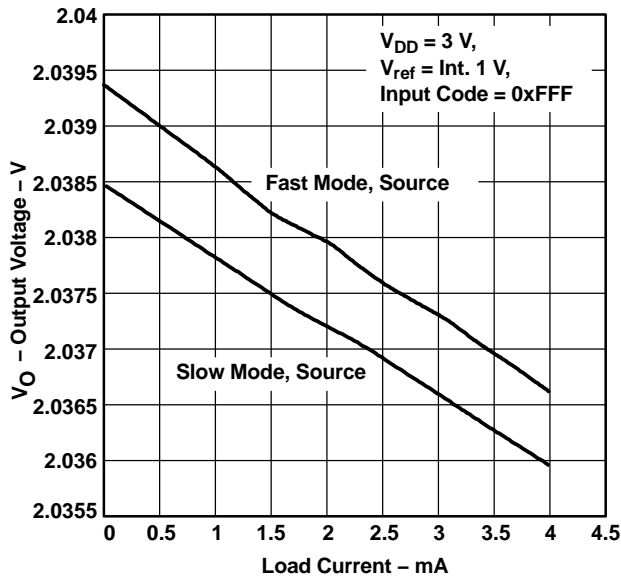

Figure 4.

MAXIMUM OUTPUT VOLTAGE
vs
LOAD CURRENT

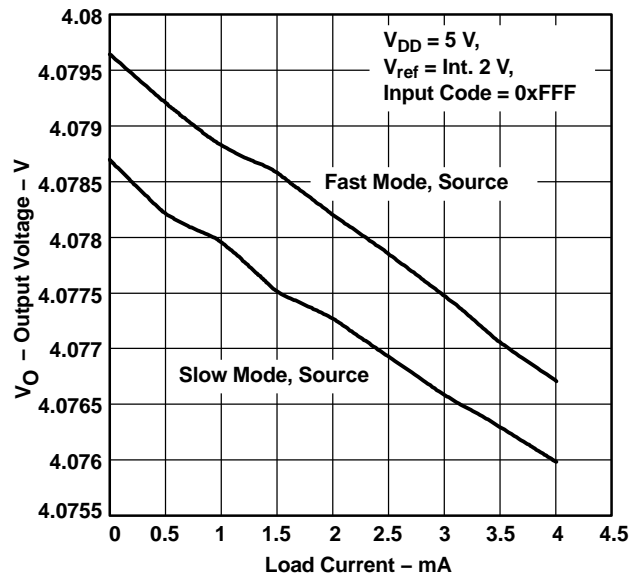

Figure 5.

MINIMUM OUTPUT VOLTAGE
vs
LOAD CURRENT

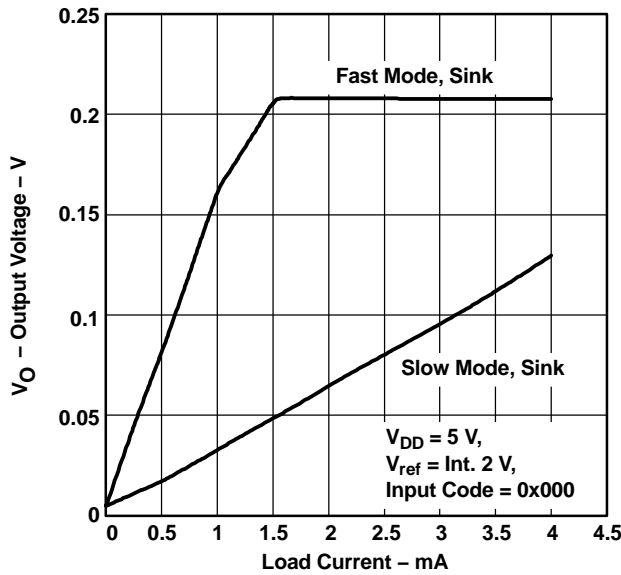

Figure 6.

MINIMUM OUTPUT VOLTAGE
vs
LOAD CURRENT

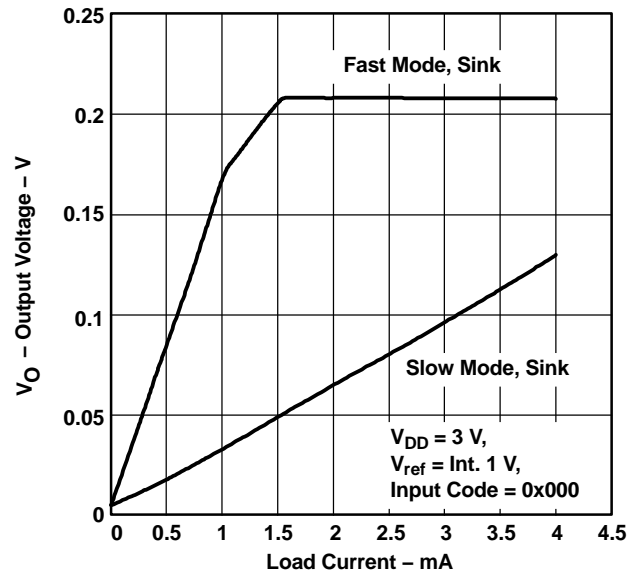

Figure 7.

TYPICAL CHARACTERISTICS (continued)

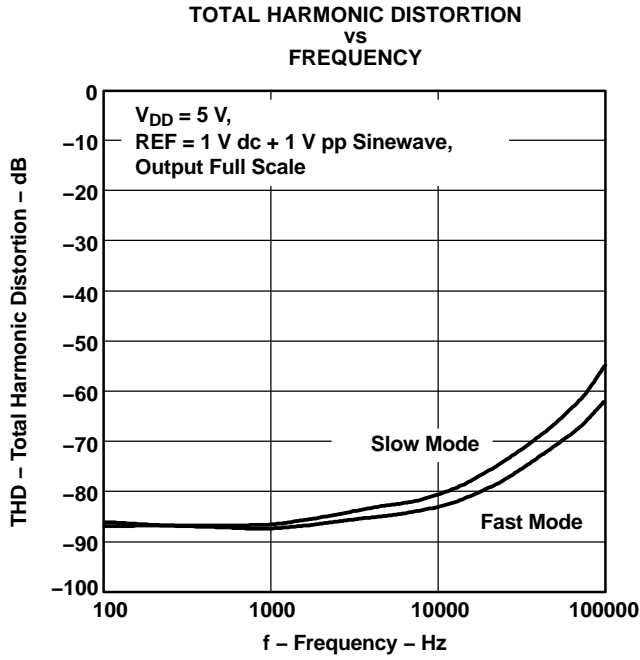

Figure 8.

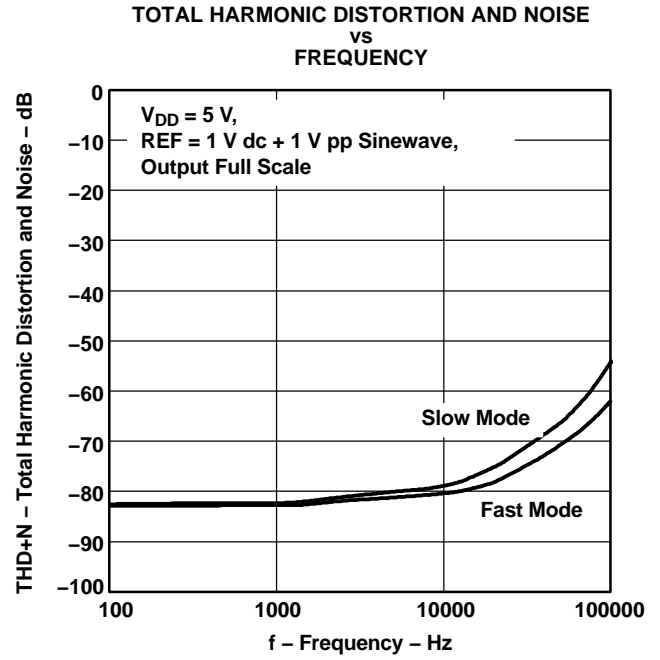

Figure 9.

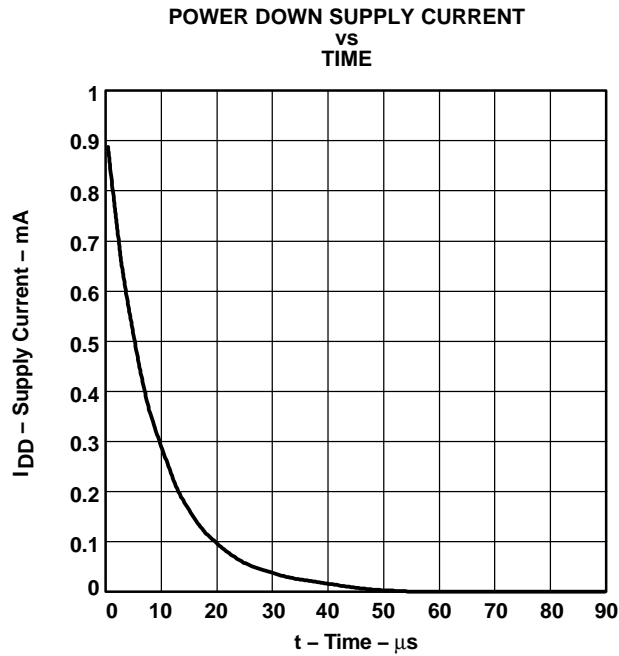

Figure 10.

APPLICATION INFORMATION

GENERAL FUNCTION

The TLV5639 is a 12-bit, single supply DAC, based on a resistor string architecture. It consists of a parallel interface, a speed and power down control logic, a programmable internal reference, a resistor string, and a rail-to-rail output buffer. The output voltage (full scale determined by reference) is given by:

$$2 \text{ REF } \frac{\text{CODE}}{0x1000} \text{ [V]}$$

Where REF is the reference voltage and CODE is the digital input value in the range 0x000 to 0xFFFF. A power-on reset initially puts the internal latches to a defined state (all bits zero).

PARALLEL INTERFACE

The device latches data on the positive edge of $\overline{\text{WE}}$. It must be enabled with $\overline{\text{CS}}$ low. Whether the data is written to the DAC holding latch or the control register depends on REG. REG = 0 selects the DAC holding latch, REG = 1 selects the control register. $\overline{\text{LDAC}}$ low updates the DAC with the value in the holding latch. $\overline{\text{LDAC}}$ is an asynchronous input and can be held low, if a separate update is not necessary. However, to control the DAC using the load feature, there should be approximately a 5 ns delay after the positive $\overline{\text{WE}}$ edge before driving $\overline{\text{LDAC}}$ low.

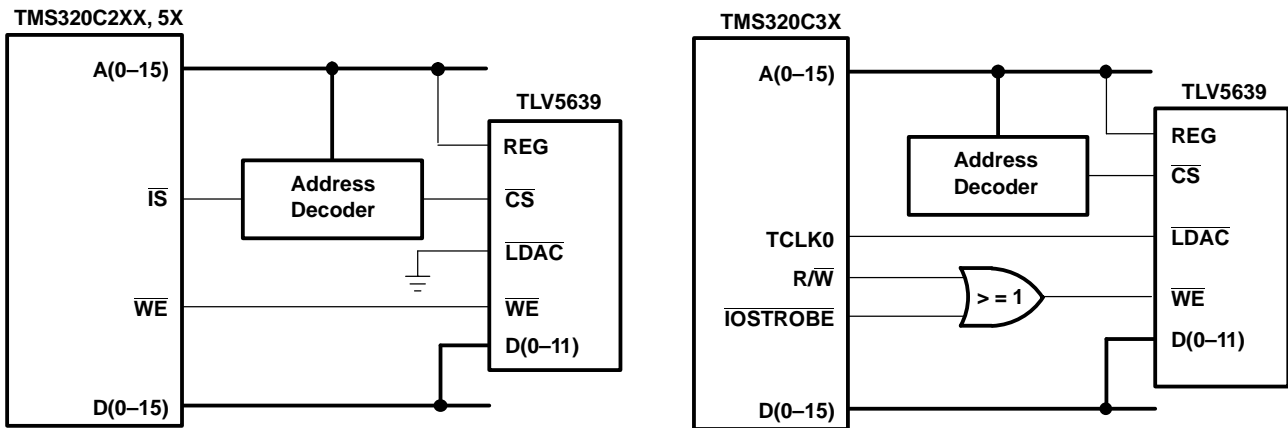

Figure 11.

DATA FORMAT

The TLV5639 writes data either to the DAC holding latch or to the control register, depending on the level of the REG input.

Data destination:

REG = 0 → DAC holding latch

REG = 1 → control register

APPLICATION INFORMATION (continued)

The following table lists the meaning of the bits within the control register:

| D11 | D10 | D9 | D8 | D7 | D6 | D5 | D4 | D3 | D2 | D1 | D0 |
|------------------|------------------|------------------|------------------|------------------|------------------|------------------|------------------|------------------|------------------|------------------|------------------|
| X | X | X | X | X | X | X | REF1 | REF0 | X | PWR | SPD |
| X ⁽¹⁾ | X ⁽¹⁾ | X ⁽¹⁾ | X ⁽¹⁾ | X ⁽¹⁾ | X ⁽¹⁾ | X ⁽¹⁾ | 0 ⁽¹⁾ | 0 ⁽¹⁾ | X ⁽¹⁾ | 0 ⁽¹⁾ | 0 ⁽¹⁾ |

(1) Default values

SPD : Speed control bit 1 = fast mode 0 = slow mode
 PWR : Power control bit 1 = power down 0 = normal operation

REF1 and REF0 determine the reference source and the reference voltage.

REFERENCE BITS

| REF1 | REF0 | REFERENCE |
|------|------|-----------|
| 0 | 0 | External |
| 0 | 1 | 1.024 V |
| 1 | 0 | 2.048 V |
| 1 | 1 | External |

If an external reference voltage is applied to the REF pin, external reference must be selected.

LINEARITY, OFFSET, AND GAIN ERROR USING SINGLE END SUPPLIES

When an amplifier is operated from a single supply, the voltage offset can still be either positive or negative. With a positive offset, the output voltage changes on the first code change. With a negative offset the output voltage may not change with the first code depending on the magnitude of the offset voltage.

The output amplifier attempts to drive the output to a negative voltage. However, because the most negative supply rail is ground, the output cannot drive below ground and clamps the output at 0 V.

The output voltage remains at zero until the input code value produces a sufficient positive output voltage to overcome the negative offset voltage, resulting in the transfer function shown in Figure 12.

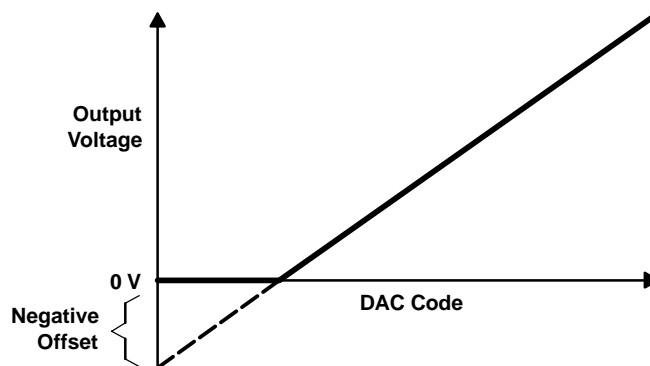

Figure 12. Effect of Negative Offset (Single Supply)

This offset error, not the linearity error, produces this breakpoint. The transfer function would have followed the dotted line if the output buffer could drive below the ground rail.

For a DAC, linearity is measured between zero input code (all inputs 0) and full scale code (all inputs 1) after offset and full scale are adjusted out or accounted for in some way. However, single supply operation does not allow for adjustment when the offset is negative due to the breakpoint in the transfer function. So the linearity is measured between full scale code and the lowest code that produces a positive output voltage.

TLV5639 INTERFACED to TMS320C203 DSP

HARDWARE INTERFACE

Figure 13 shows an example of the connection between the TLV5639 and the TMS320C203 DSP. The only other device that is needed in addition to the DSP and the DAC is the 74AC138 address decoding circuit. Using this configuration, the DAC data is at address 0x0084 and the DAC control word is at address 0x0085 within the I/O memory space of the TMS320C203.

$\overline{\text{LDAC}}$ is tied low so that the output voltage is updated on the rising $\overline{\text{WE}}$ edge.

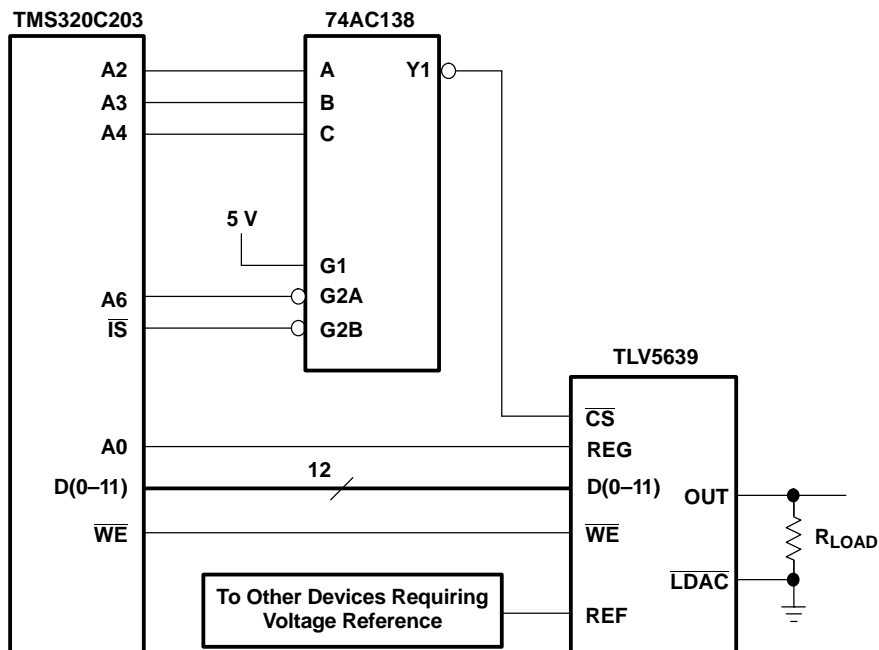

Figure 13. TLV5639 to TMS320C203 DSP Interface Connection

SOFTWARE

Writing data or control information to the TLV5639 is done using a single command. For example, the line of code which reads:

```
out 62h, dac_ctrl
```

writes the contents of address 0x0062 to the I/O address equated to dac_ctrl (0x0085, the address where the DAC control register has been mapped).

The following code shows how to set the DAC up to use the internal reference and operate in FAST mode by a write to the control register. Timer interrupts are then enabled and repeatedly generated every 205 μs to provide a timebase for synchronizing the waveform generation. In this example, the waveform is generated by simply incrementing a counter and outputting the counter value to the DAC data word once every timer interrupt. This results in a saw waveform.

```
; File:          RAMP.ASM
; Function:      ramp generation with TLV5639
; Processors:   TMS320C203
; { 1999 Texas Instruments

;----- I/O and memory mapped regs -----
        .include regs.asm
dac_data
.equ
0084h
dac_ctrl
.equ
0085h
;----- vectors -----
        .ps
0h

b
start
        b
INT1
        b
INT23
        b
TIM_ISR

-----Main Program-----
        .ps
1000h
        .entry
start:
        ldp
#0
; set data page to 0
; disable interrupts
        setc
INTM
; disable maskable interrupts
        splk
#0ffffh, IFR
        splk
#0004h, IMR

; set up the timer
        splk
#0000h, 60h
        splk
#0042h, 61h

out
61h, PRD
        out
60h, TIM

splk
#0c2fh, 62h
        out
62h, TCR

        splk
#0011h, 62h ; set up the DAC
; SPD=1 (FAST mode) and ; REF1=1 (2.048 V internal ref enable)
        out
```

62h, dac_ctrl

 clrc
INTM ; enable interrupts

; loop forever!
next
 idle
b next

----- Interrupt Service Routines-----

INT1:
 ret
; do nothing and return
INT23:
 ret
; do nothing and return
TIM_ISR:
; timer interrupt handler
 add
#1h
; increment accumulator

sacl
60h
 out
60h, dac_data ; write to DAC
 clrc
intm
 ; re-enable interrupts
 ret
 ; return from interrupt
 .END

PACKAGING INFORMATION

| Orderable Device | Status ⁽¹⁾ | Package Type | Package Drawing | Pins | Package Qty | Eco Plan ⁽²⁾ | Lead/Ball Finish | MSL Peak Temp ⁽³⁾ |
|------------------|-----------------------|--------------|-----------------|------|-------------|-------------------------|------------------|------------------------------|
| TLV5639CDW | ACTIVE | SOIC | DW | 20 | 25 | Green (RoHS & no Sb/Br) | CU NIPDAU | Level-1-260C-UNLIM |
| TLV5639CDWG4 | ACTIVE | SOIC | DW | 20 | 25 | Green (RoHS & no Sb/Br) | CU NIPDAU | Level-1-260C-UNLIM |
| TLV5639CDWR | ACTIVE | SOIC | DW | 20 | 2000 | Green (RoHS & no Sb/Br) | CU NIPDAU | Level-1-260C-UNLIM |
| TLV5639CDWRG4 | ACTIVE | SOIC | DW | 20 | 2000 | Green (RoHS & no Sb/Br) | CU NIPDAU | Level-1-260C-UNLIM |
| TLV5639CPW | ACTIVE | TSSOP | PW | 20 | 70 | Green (RoHS & no Sb/Br) | CU NIPDAU | Level-1-260C-UNLIM |
| TLV5639CPWG4 | ACTIVE | TSSOP | PW | 20 | 70 | Green (RoHS & no Sb/Br) | CU NIPDAU | Level-1-260C-UNLIM |
| TLV5639IDW | ACTIVE | SOIC | DW | 20 | 25 | Green (RoHS & no Sb/Br) | CU NIPDAU | Level-1-260C-UNLIM |
| TLV5639IDWG4 | ACTIVE | SOIC | DW | 20 | 25 | Green (RoHS & no Sb/Br) | CU NIPDAU | Level-1-260C-UNLIM |
| TLV5639IPW | ACTIVE | TSSOP | PW | 20 | 70 | Green (RoHS & no Sb/Br) | CU NIPDAU | Level-1-260C-UNLIM |
| TLV5639IPWG4 | ACTIVE | TSSOP | PW | 20 | 70 | Green (RoHS & no Sb/Br) | CU NIPDAU | Level-1-260C-UNLIM |
| TLV5639IPWR | ACTIVE | TSSOP | PW | 20 | 2000 | Green (RoHS & no Sb/Br) | CU NIPDAU | Level-1-260C-UNLIM |
| TLV5639IPWRG4 | ACTIVE | TSSOP | PW | 20 | 2000 | Green (RoHS & no Sb/Br) | CU NIPDAU | Level-1-260C-UNLIM |

⁽¹⁾ The marketing status values are defined as follows:

ACTIVE: Product device recommended for new designs.

LIFEBUY: TI has announced that the device will be discontinued, and a lifetime-buy period is in effect.

NRND: Not recommended for new designs. Device is in production to support existing customers, but TI does not recommend using this part in a new design.

PREVIEW: Device has been announced but is not in production. Samples may or may not be available.

OBSOLETE: TI has discontinued the production of the device.

⁽²⁾ Eco Plan - The planned eco-friendly classification: Pb-Free (RoHS), Pb-Free (RoHS Exempt), or Green (RoHS & no Sb/Br) - please check <http://www.ti.com/productcontent> for the latest availability information and additional product content details.

TBD: The Pb-Free/Green conversion plan has not been defined.

Pb-Free (RoHS): TI's terms "Lead-Free" or "Pb-Free" mean semiconductor products that are compatible with the current RoHS requirements for all 6 substances, including the requirement that lead not exceed 0.1% by weight in homogeneous materials. Where designed to be soldered at high temperatures, TI Pb-Free products are suitable for use in specified lead-free processes.

Pb-Free (RoHS Exempt): This component has a RoHS exemption for either 1) lead-based flip-chip solder bumps used between the die and package, or 2) lead-based die adhesive used between the die and leadframe. The component is otherwise considered Pb-Free (RoHS compatible) as defined above.

Green (RoHS & no Sb/Br): TI defines "Green" to mean Pb-Free (RoHS compatible), and free of Bromine (Br) and Antimony (Sb) based flame retardants (Br or Sb do not exceed 0.1% by weight in homogeneous material)

⁽³⁾ MSL, Peak Temp. -- The Moisture Sensitivity Level rating according to the JEDEC industry standard classifications, and peak solder temperature.

Important Information and Disclaimer: The information provided on this page represents TI's knowledge and belief as of the date that it is provided. TI bases its knowledge and belief on information provided by third parties, and makes no representation or warranty as to the accuracy of such information. Efforts are underway to better integrate information from third parties. TI has taken and continues to take reasonable steps to provide representative and accurate information but may not have conducted destructive testing or chemical analysis on incoming materials and chemicals. TI and TI suppliers consider certain information to be proprietary, and thus CAS numbers and other limited information may not be available for release.

In no event shall TI's liability arising out of such information exceed the total purchase price of the TI part(s) at issue in this document sold by TI to Customer on an annual basis.

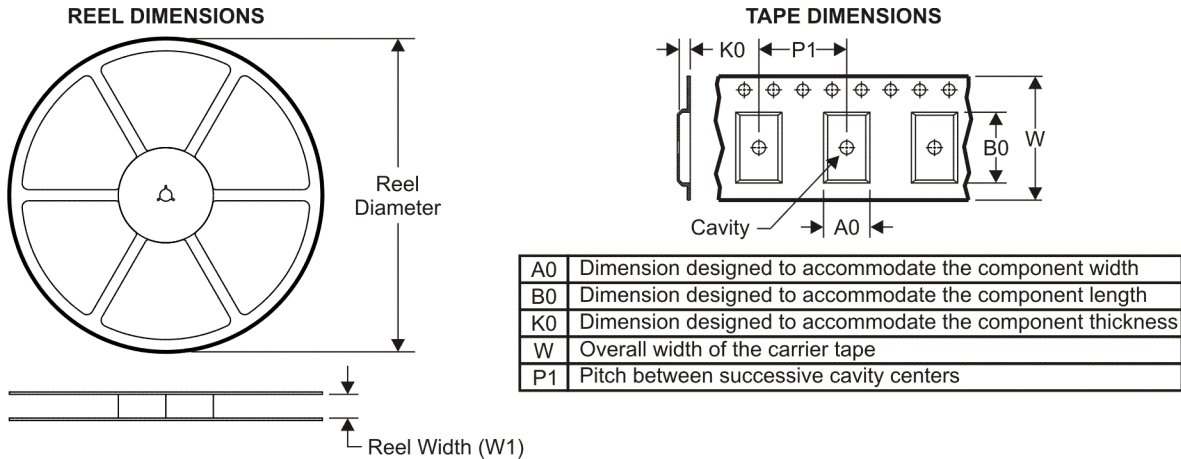
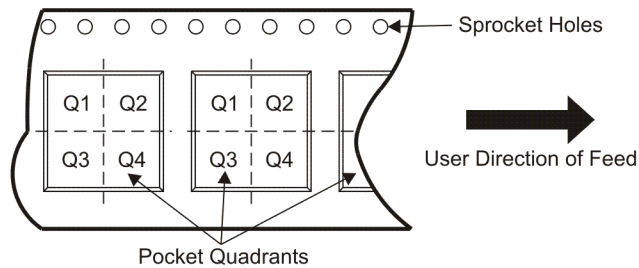
TAPE AND REEL INFORMATION

QUADRANT ASSIGNMENTS FOR PIN 1 ORIENTATION IN TAPE

*All dimensions are nominal

| Device | Package Type | Package Drawing | Pins | SPQ | Reel Diameter (mm) | Reel Width W1 (mm) | A0 (mm) | B0 (mm) | K0 (mm) | P1 (mm) | W (mm) | Pin1 Quadrant |
|-------------|--------------|-----------------|------|------|--------------------|--------------------|---------|---------|---------|---------|--------|---------------|
| TLV5639IPWR | TSSOP | PW | 20 | 2000 | 330.0 | 16.4 | 6.95 | 7.1 | 1.6 | 8.0 | 16.0 | Q1 |

TAPE AND REEL BOX DIMENSIONS



*All dimensions are nominal

| Device | Package Type | Package Drawing | Pins | SPQ | Length (mm) | Width (mm) | Height (mm) |
|-------------|--------------|-----------------|------|------|-------------|------------|-------------|
| TLV5639IPWR | TSSOP | PW | 20 | 2000 | 346.0 | 346.0 | 33.0 |

PW (R-PDSO-G**)

PLASTIC SMALL-OUTLINE PACKAGE

14 PINS SHOWN



4040064/F 01/97

- NOTES: A. All linear dimensions are in millimeters.
 B. This drawing is subject to change without notice.
 C. Body dimensions do not include mold flash or protrusion not to exceed 0,15.
 D. Falls within JEDEC MO-153

DW (R-PDSO-G20)

PLASTIC SMALL-OUTLINE PACKAGE

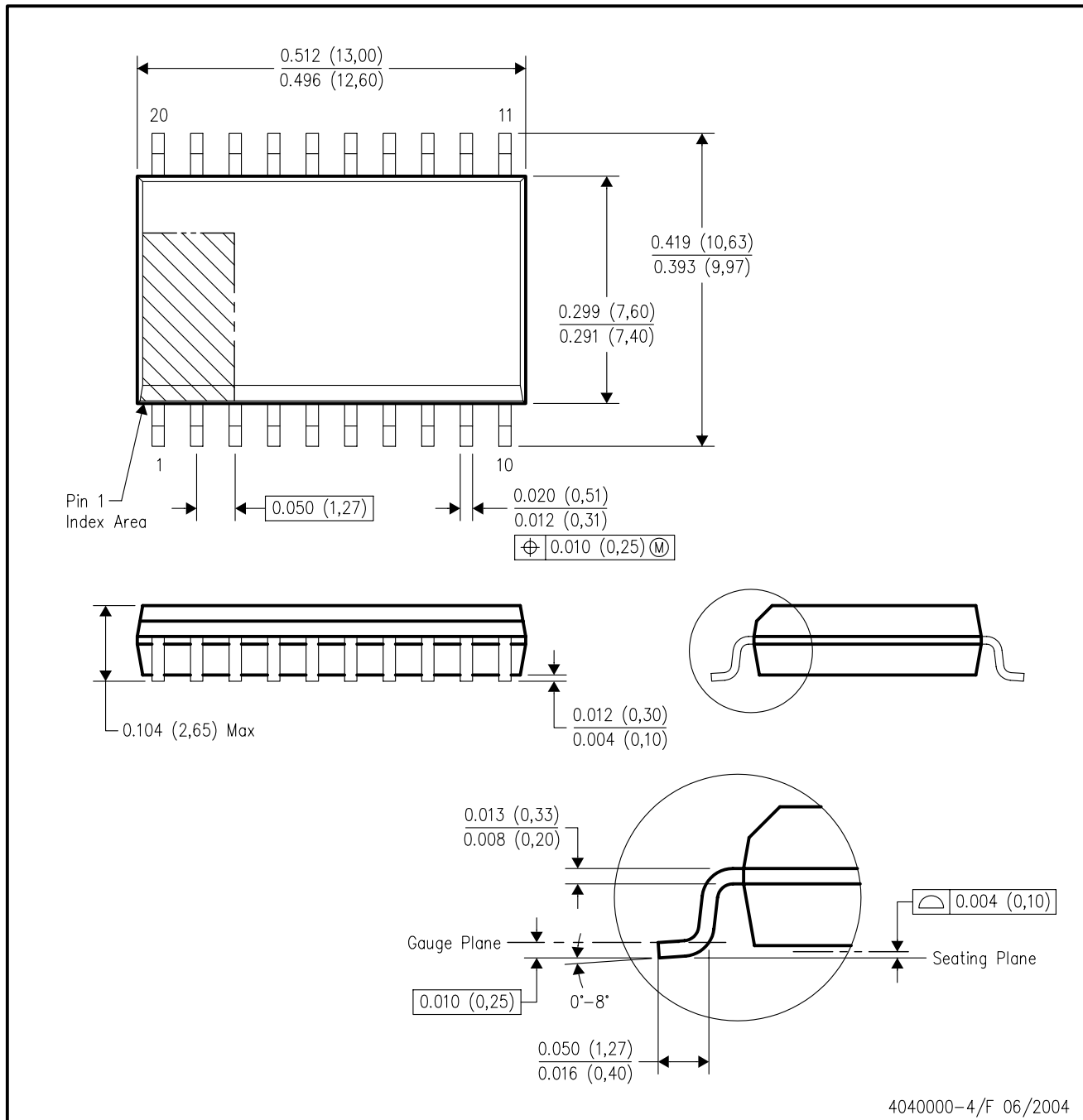

- NOTES:
- A. All linear dimensions are in inches (millimeters).
 - B. This drawing is subject to change without notice.
 - C. Body dimensions do not include mold flash or protrusion not to exceed 0.006 (0,15).
 - D. Falls within JEDEC MS-013 variation AC.

IMPORTANT NOTICE

Texas Instruments Incorporated and its subsidiaries (TI) reserve the right to make corrections, modifications, enhancements, improvements, and other changes to its products and services at any time and to discontinue any product or service without notice. Customers should obtain the latest relevant information before placing orders and should verify that such information is current and complete. All products are sold subject to TI's terms and conditions of sale supplied at the time of order acknowledgment.

TI warrants performance of its hardware products to the specifications applicable at the time of sale in accordance with TI's standard warranty. Testing and other quality control techniques are used to the extent TI deems necessary to support this warranty. Except where mandated by government requirements, testing of all parameters of each product is not necessarily performed.

TI assumes no liability for applications assistance or customer product design. Customers are responsible for their products and applications using TI components. To minimize the risks associated with customer products and applications, customers should provide adequate design and operating safeguards.

TI does not warrant or represent that any license, either express or implied, is granted under any TI patent right, copyright, mask work right, or other TI intellectual property right relating to any combination, machine, or process in which TI products or services are used. Information published by TI regarding third-party products or services does not constitute a license from TI to use such products or services or a warranty or endorsement thereof. Use of such information may require a license from a third party under the patents or other intellectual property of the third party, or a license from TI under the patents or other intellectual property of TI.

Reproduction of TI information in TI data books or data sheets is permissible only if reproduction is without alteration and is accompanied by all associated warranties, conditions, limitations, and notices. Reproduction of this information with alteration is an unfair and deceptive business practice. TI is not responsible or liable for such altered documentation. Information of third parties may be subject to additional restrictions.

Resale of TI products or services with statements different from or beyond the parameters stated by TI for that product or service voids all express and any implied warranties for the associated TI product or service and is an unfair and deceptive business practice. TI is not responsible or liable for any such statements.

TI products are not authorized for use in safety-critical applications (such as life support) where a failure of the TI product would reasonably be expected to cause severe personal injury or death, unless officers of the parties have executed an agreement specifically governing such use. Buyers represent that they have all necessary expertise in the safety and regulatory ramifications of their applications, and acknowledge and agree that they are solely responsible for all legal, regulatory and safety-related requirements concerning their products and any use of TI products in such safety-critical applications, notwithstanding any applications-related information or support that may be provided by TI. Further, Buyers must fully indemnify TI and its representatives against any damages arising out of the use of TI products in such safety-critical applications.

TI products are neither designed nor intended for use in military/aerospace applications or environments unless the TI products are specifically designated by TI as military-grade or "enhanced plastic." Only products designated by TI as military-grade meet military specifications. Buyers acknowledge and agree that any such use of TI products which TI has not designated as military-grade is solely at the Buyer's risk, and that they are solely responsible for compliance with all legal and regulatory requirements in connection with such use.

TI products are neither designed nor intended for use in automotive applications or environments unless the specific TI products are designated by TI as compliant with ISO/TS 16949 requirements. Buyers acknowledge and agree that, if they use any non-designated products in automotive applications, TI will not be responsible for any failure to meet such requirements.

Following are URLs where you can obtain information on other Texas Instruments products and application solutions:

Products

| | |
|-----------------------------|--|
| Amplifiers | amplifier.ti.com |
| Data Converters | dataconverter.ti.com |
| DLP® Products | www.dlp.com |
| DSP | dsp.ti.com |
| Clocks and Timers | www.ti.com/clocks |
| Interface | interface.ti.com |
| Logic | logic.ti.com |
| Power Mgmt | power.ti.com |
| Microcontrollers | microcontroller.ti.com |
| RFID | www.ti-rfid.com |
| RF/IF and ZigBee® Solutions | www.ti.com/lprf |

Applications

| | |
|--------------------|--|
| Audio | www.ti.com/audio |
| Automotive | www.ti.com/automotive |
| Broadband | www.ti.com/broadband |
| Digital Control | www.ti.com/digitalcontrol |
| Medical | www.ti.com/medical |
| Military | www.ti.com/military |
| Optical Networking | www.ti.com/opticalnetwork |
| Security | www.ti.com/security |
| Telephony | www.ti.com/telephony |
| Video & Imaging | www.ti.com/video |
| Wireless | www.ti.com/wireless |

Mailing Address: Texas Instruments, Post Office Box 655303, Dallas, Texas 75265
Copyright © 2009, Texas Instruments Incorporated