

# Solid State Relays Industrial, 3-Phase ZS Types RZ .... HD P., RZ .... HA P.



- 3-phase Solid State Relay
- Zero switching
- Rated operational current: 3 x 10, 25, 40 or 55 AACrms
- Rated operational voltage: Up to 690 VACrms
- Control voltage 10 to 40 VDC or 20 to 265 VAC/DC
- Transient overvoltage protection built-in
- Prepared for overtemperature protection
- Pilot duty switch available as an option
- IP 10 back-of-hand protection

## Product Description

A Solid State Relay family designed to switch various loads such as heating elements, motors and transformers. The relay is capable of switching high voltages up to 690 VACrms.

### Technique

For higher reliability and load cycle capability three alternistor chips are soldered directly on to the direct copper bonded (DCB) substrate. AC-

or DC-controlled versions are available. Built-in LED status indication for applied control voltage. Other features include overvoltage protection via the varistors and the possibility of installing a thermostat for overtemperature protection. When equipped with a pilot duty switch and connected to a mechanical relay a hybrid function is achieved, and it is no longer necessary to use a heatsink.

## Ordering Key

**R Z 48 55 HA P0**

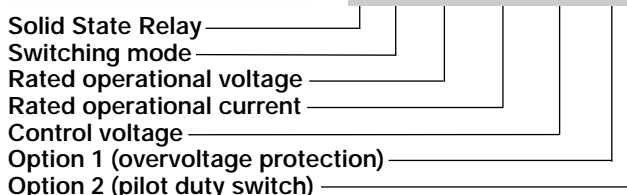

## Type Selection

Switching mode	Rated operational voltage	Rated operational current	Control voltage	Option 1 (protection)	Option 2 (pilot duty switch)
RZ	40: 400 VACrms 48: 480 VACrms	10: 10 AACrms 25: 25 AACrms 40: 40 AACrms 55: 55 AACrms	HD: 10 - 40 VDC HA: 20 - 265 VAC/DC	P: Protected J: Unprotected	0: Without PDS 1: 1 A/230 VAC 2: 1 A/24 VDC

## Selection Guide

Rated operational voltage	Control voltage	Rated operational current			
		10 AACrms	25 AACrms	40 AACrms	55 AACrms
400 VACrms	10 - 40 VDC	RZ 4010 HD P.	RZ 4025 HD P.	RZ 4040 HD P.	RZ 4055 HD P.
	20 - 265 VAC/DC	RZ 4010 HA P.	RZ 4025 HA P.	RZ 4040 HA P.	RZ 4055 HA P.
480 VACrms	10 - 40 VDC	RZ 4810 HD P.	RZ 4825 HD P.	RZ 4840 HD P.	RZ 4855 HD P.
	20 - 265 VAC/DC	RZ 4810 HA P.	RZ 4825 HA P.	RZ 4840 HA P.	RZ 4855 HA P.

### Options

- 1 Protection: unprotected version only available on request.
- 2 Pilot duty switch: add suffix 1 or 2 for pilot duty switch (e.g. 1 A/230 VAC). Example: RZ 4025 HDP1.  
Ordering example for RZ-relay with built-in varistors and pilot duty switch: RZ 4025 HDP1.

## General Specifications

	RZ 40... P.	RZ 48... P.
Operational voltage ranges		
Line to neutral	12 to 440 VACrms	12 to 530 VACrms
Line to line (load connected to neutral)	12 to 400 VACrms	12 to 660 VACrms
Non-rep. peak voltage	$\geq 1000 V_p$	$\geq 1200 V_p$
Varistor voltage	420 VACrms	510 VACrms
Operational frequency range	45 to 65 Hz	45 to 65 Hz
Overvoltage category	III	III
Pollution degree	3	2
Approvals	CSA, UL	CSA, UL
CE-marking	Yes	Yes

Star  
(load connected to neutral)

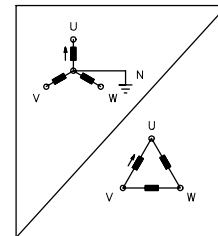

Delta

## Input Specifications

	RZ .... HD P0	RZ .... HA P0	RZ .... HD P2	RZ .... HA P1
Control voltage range	10 to 40 VDC FELV-SELV-PELV	20 to 265 VAC/DC FELV-SELV- PELV/line	10 to 40 VDC FELV-SELV-PELV	20 to 265 VAC/DC FELV-SELV- PELV/line
Pick-up voltage	$\leq 10$ VDC	$\leq 20$ VAC/DC	$\leq 10$ VDC	$\leq 20$ VAC/DC
Drop-out voltage	$\geq 3$ VDC	$\geq 5$ VAC/DC	$\geq 3$ VDC	$\geq 5$ VAC/DC
Input current	$\leq 18$ mADC @ 10 V <sub>in</sub> $\leq 22$ mADC @ 24 V <sub>in</sub> $\leq 28$ mADC @ 40 V <sub>in</sub>	$\leq 20$ mA AC/DC	$\leq 18$ mADC @ 10 V <sub>in</sub> $\leq 30$ mADC @ 24 V <sub>in</sub> $\leq 40$ mADC @ 40 V <sub>in</sub>	$\leq 20$ mA AC/DC
Response time pick-up				
Power output	$\leq 10$ ms	$\leq 10$ ms	$\leq 10$ ms	$\leq 10$ ms
Pilot duty switch	-	-	$\leq 10$ ms	$\leq 10$ ms
Response time drop-out				
Power output	$\leq 20$ ms	$\leq 40$ ms	$\leq 100$ ms	$\leq 100$ ms
Pilot duty switch	-	-	$\leq 10$ ms	$\leq 20$ ms

## Output Specifications

	RZ ..10 .. P.	RZ ..25 .. P.	RZ ..40 .. P.	RZ ..55 .. P.
Rated operational current				
AC51 ratings	10 Arms	25 Arms	40 Arms	55 Arms
AC53a ratings	2 Arms	5 Arms	8 Arms	15 Arms
Minimum operational current	100 mArms	100 mArms	200 mArms	200 mArms
Rep. overload current	$t=1$ s $\leq 18$ Arms $t=5$ s $\leq 15$ Arms	$\leq 37$ Arms $\leq 32$ Arms	$\leq 60$ Arms $\leq 50$ Arms	$\leq 85$ Arms $\leq 70$ Arms
Non-rep. surge current $t = 20$ ms	120 A <sub>p</sub>	230 A <sub>p</sub>	300 A <sub>p</sub>	550 A <sub>p</sub>
Off-state leakage current	$\leq 10$ mArms	$\leq 10$ mArms	$\leq 10$ mArms	$\leq 10$ mArms
I <sup>2</sup> t for fusing $t = 1-10$ ms	$\leq 72$ A <sup>2</sup> s	$\leq 265$ A <sup>2</sup> s	$\leq 450$ A <sup>2</sup> s	$\leq 1500$ A <sup>2</sup> s
Critical di/dt	$\geq 50$ A/ $\mu$ s	$\geq 50$ A/ $\mu$ s	$\geq 100$ A/ $\mu$ s	$\geq 100$ A/ $\mu$ s
On-state voltage drop	$\leq 1.6$ Vrms	$\leq 1.6$ Vrms	$\leq 1.6$ Vrms	$\leq 1.6$ Vrms
Critical dv/dt off state	$\geq 500$ V/ $\mu$ s	$\geq 500$ V/ $\mu$ s	$\geq 500$ V/ $\mu$ s	$\geq 500$ V/ $\mu$ s

## Thermal Specifications

	RZ ..10 ..	RZ ..25 ..	RZ ..40 ..	RZ ..55 ..
Operating temperature	-20° to +70°C (-4° to +158°F)	-20° to +70°C (-4° to +158°F)	-20° to +70°C (-4° to +158°F)	-20° to +70°C (-4° to +158°F)
Storage temperature	-40° to +100°C (-40° to +212°F)	-40° to +100°C (-40° to +212°F)	-40° to +100°C (-40° to +212°F)	-40° to +100°C (-40° to +212°F)
Junction temperature	≤ 125°C (≤ 257°F)	≤ 125°C (≤ 257°F)	≤ 125°C (≤ 257°F)	≤ 125°C (≤ 257°F)
R <sub>th</sub> junction to case 3-phase	0.75 K/W	0.5 K/W	0.3 K/W	0.2 K/W
1-phase	2.25 K/W	1.5 K/W	1.0 K/W	0.6 K/W

## Option 1 - Overvoltage Protection

Transients are generated by overvoltage of atmospheric origin on the public distribution system or when motors, solenoids, valves, lights, heaters or any electrically operated equipment are connected to or disconnected from the power source. To perform a transient voltage clipping or suppression func-

tion on the AC-load side of an RZ relay, metal oxide varistors (MOV) are normally built in. MOV's assume a low impedance state when their voltage threshold is exceeded. Carlo Gavazzi SSR's are optionally available without varistors if no transient protection is required.

## Insulation

	ACrms 3 cycles	ACrms 1 min
Rated insulation voltage		
Input to output	≥ 5660 V	≥ 4000 V
Input to pilot duty switch	≥ 5660 V	≥ 4000 V
Input to heatsink	≥ 5660 V	≥ 4000 V
Rated insulation voltage		
Output to heatsink	≥ 4240 V	≥ 4000 V
Output to output	≥ 4240 V	≥ 4000 V
Output to pilot duty switch	≥ 4240 V	≥ 4000 V

## Option 2 - Pilot Duty Switch

The RZ relay is available either with or without pilot duty switch (PDS).

Equipped with the PDS and connected to a mechanical relay, a hybrid function is achieved and it is no longer necessary to use a heatsink. The built-in timing function of the relay will ensure that the switching on and switching off is carried out by the Solid State Relay. As soon as the control voltage is applied, the power output turns on and the full voltage is applied to

the load. After max. 10 ms, the PDS will activate the contactor shunting the SSR in about 20 ms. As the load is already under full voltage, the contactor does not take any high inrush currents. It only bypasses the SSR. When the control voltage is removed, the pilot duty switch will first disconnect the contactor. After a delay of min. 30 ms, the power outputs will be off max. 100 ms after the input control voltage has been removed.

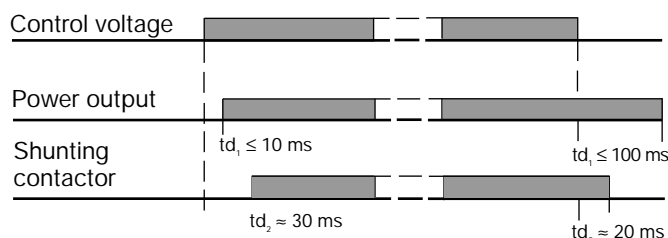

td<sub>1</sub> = time delay semiconductor  
td<sub>2</sub> = time delay contactor

	PDS 01	PDS 02
Operational voltage range	24 to 280 VACrms	5 to 24 VDC
Rated operational current	≤ 1 Arms @ 40°C ≤ 0.85 Arms @ 50°C ≤ 0.7 Arms @ 60°C ≤ 0.55 Arms @ 70°C	≤ 1 A @ 40°C ≤ 0.85 A @ 50°C ≤ 0.7 A @ 60°C ≤ 0.5 A @ 70°C
Non-rep. surge current t = 20 ms	30 A <sub>p</sub>	-
Rep. overload current t = 1s	5 Arms	2 A DC
I <sup>2</sup> t for fusing t=1-10 ms	5 A <sup>2</sup> s	-
Off-state leakage current	≤ 1 mArms	≤ 1 mA DC
On-state voltage	1.2 VACrms	1.5 VDC



## Heatsink Dimensions (load current versus ambient temperature)

### RZ ..10.. ..

Load current [A]	Thermal resistance [K/W]					Power dissipation [W]	Temp. protection [°C]
12	1.7	1.4	1.2	1.0	0.7	41	90°C
11	2.0	1.7	1.4	1.2	0.9	37	
10	2.3	2.0	1.7	1.4	1.1	33	
9	2.7	2.4	2.0	1.7	1.3	29	
8	3.1	2.7	2.3	1.9	1.5	25	
7	3.7	3.2	2.7	2.3	1.8	21	
6	4.4	3.8	3.3	2.7	2.2	18	
5	5.4	4.7	4.1	3.4	2.7	15	
4	7.0	6.1	5.2	4.3	3.5	12	
3	9.5	8.3	7.1	5.9	4.7	8	
2	14.7	12.9	11.0	9.2	7.3	5	
	20	30	40	50	60	$T_A$	

### RZ ..25.. ..

Load current [A]	Thermal resistance [K/W]					Power dissipation [W]	Temp. protection [°C]	
25	0.46	0.36	0.26	-	-	101	70°C	
22.5	0.62	0.50	0.39	0.28	-	88	80°C	
20	0.81	0.68	0.55	0.42	0.28	76	90°C	
17.5	1.0	0.91	0.76	0.60	0.44	64		
15	1.4	1.2	1.0	0.85	0.66	53		
12.5	1.9	1.6	1.4	1.1	0.95	43		
10	2.4	2.1	1.8	1.5	1.2	33		
7.5	3.4	3.0	2.5	2.1	1.7	24		
5	5.3	4.7	4.0	3.3	2.6	15		
2.5	11.2	9.8	8.4	7.0	5.6	7		
	20	30	40	50	60	$T_A$		Ambient temp [°C]

### RZ ..40.. ..

Load current [A]	Thermal resistance [K/W]					Power dissipation [W]	Temp. protection [°C]	
40	0.26	-	-	-	-	165	70°C	
36	0.36	0.29	-	-	-	143	80°C	
32	0.49	0.40	0.32	-	-	122		
28	0.65	0.55	0.46	0.36	0.26	103	90°C	
24	0.87	0.76	0.64	0.52	0.40	84		
20	1.2	1.1	0.90	0.75	0.60	67		
16	1.5	1.4	1.2	1.0	0.78	51		
12	2.2	2.0	1.7	1.4	1.1	37		
8	3.5	3.1	2.7	2.2	1.8	23		
4	7.4	6.5	5.6	4.6	3.7	11		
	20	30	40	50	60	$T_A$		Ambient temp [°C]

### RZ ..55.. ..

Load current [A]	Thermal resistance [K/W]					Power dissipation [W]	Temp. protection [°C]	
55	-	-	-	-	-	215	80°C	
50	0.28	-	-	-	-	191		
45	0.35	0.29	-	-	-	167	90°C	
40	0.45	0.38	0.31	-	-	145		
35	0.58	0.50	0.42	0.33	0.25	123		
30	0.75	0.65	0.55	0.46	0.36	103		
25	0.96	0.84	0.72	0.60	0.48	83		
20	1.3	1.1	0.93	0.78	0.62	65		
15	1.8	1.5	1.3	1.1	0.85	47		
10	2.7	2.4	2.0	1.7	1.4	30		
5	5.5	4.8	4.1	3.5	2.8	15		
	20	30	40	50	60	$T_A$		Ambient temp [°C]

## Heatsink Selection

Carlo Gavazzi Heatsink (see Accessories)	Thermal resistance
No heatsink required	$R_{th\ s-a} > 8.0$ K/W
RHS 300 Assy or backplate	5.0 K/W
RHS 301 Assy	0.8 K/W
RHS 301 F Assy	0.25 K/W
Consult your distributor	$< 0.25$ K/W

Compare the value found in the load current versus temperature chart with the standard heatsink values and select the heatsink with the next lower value.

It is recommended to protect the Solid State Relay against overheating. Therefore the chart also states the maximum switching temperature (70, 80 or 90°C) for the optional temperature limit switch.



## Functional Diagram

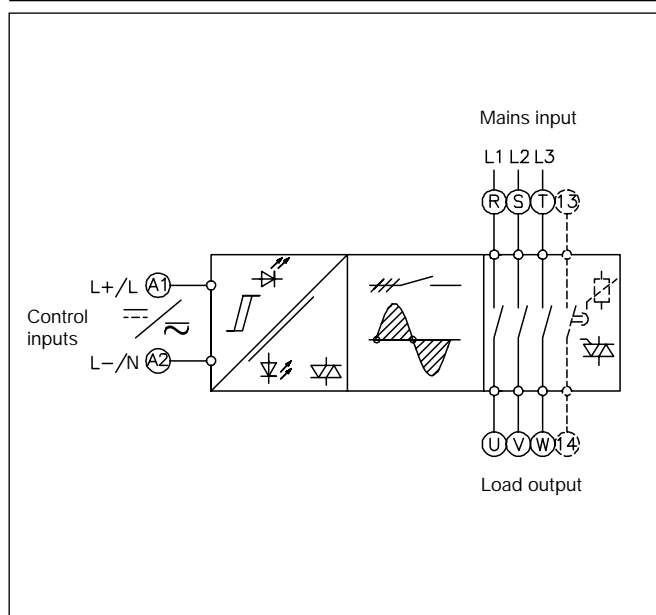

## Dimensions

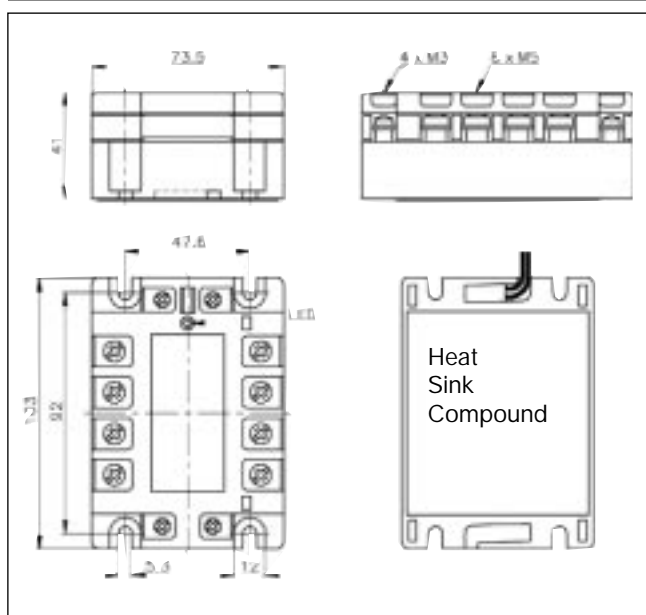

## Housing Specifications

Weight	Approx. 380 g	
Material	Noryl, glass reinforced	
Colour	Black	
Base plate	Aluminum, nickel-plated	
Potting compound	Polyurethane, black	
Relay		
Mounting screws	M5	
Mounting torque	≤ 1.5 Nm	
Control terminal		
Mounting screws	M3	
Mounting torque	≤ 0.5 Nm	
Wire size	Max.	2 x 2.5 mm <sup>2</sup>
	Min.	2 x 1.0 mm <sup>2</sup>
Power terminal		
Mounting screws	M5	
Mounting torque	≤ 2.5 Nm	
	2 x 6 mm <sup>2</sup> (AWG8)	
Wire size	Max.	2 x 6 mm <sup>2</sup>
	Min.	2 x 1 mm <sup>2</sup>

## Accessories

Protection cover  
 Heatsinks  
 Varistors  
 Fuses  
 Temperature limit switch

For further information refer to "General Accessories".

## Applications

### Switching motor loads

#### Direct switching

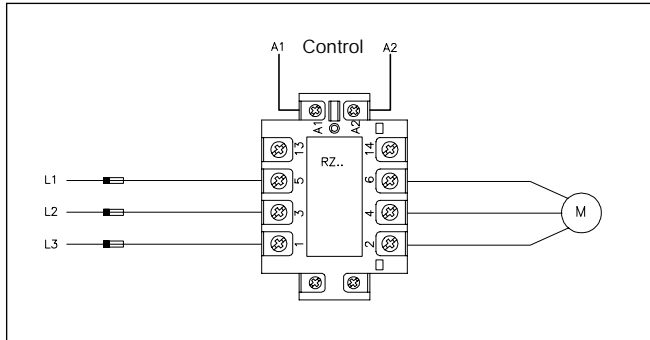

#### Selection Guide

##### 380/400 V

Motor size [kW]	[Arms]	Relay type [A]
		10 25 40 55
0.25	0.8	
0.37	1.1	
0.55	1.5	
0.75	1.9	
1.1	2.6	
1.5	3.5	
2.2	4.7	
3.0	6.2	
4.0	8.1	
5.5	10.7	
7.5	15.0	

#### Delta switching

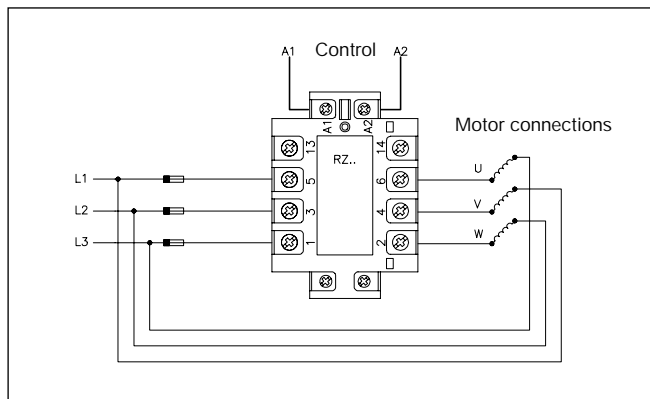

#### Selection Guide

##### 380/400 V

Motor size [kW]	[Arms]*	Relay type [A]
		10 25 40 55
1.1	1.5	
1.5	2.1	
2.2	3.0	
3.0	4.0	
4.0	4.6	
5.5	6.2	
7.5	8.7	
11.0	12.1	
15.0	16.2	

\*  $I/\sqrt{3}$ .

### Motor start with shunting by electromechanical relay (no heatsink needed)

#### Direct switching

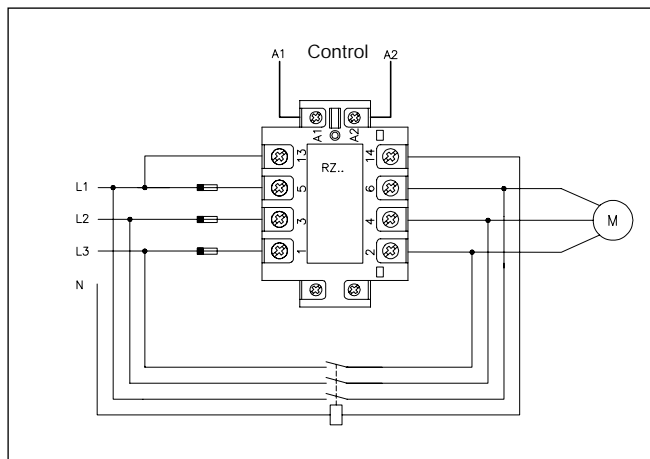

#### Selection Guide

##### 380/400 V

Motor size [kW]	[Arms]	Relay type [A]
		10 25 40 55
3.0	7.0	
5.5	11.9	
7.5	15.3	
15	29	