

## IS1640

## OPIC Light Detector

### OPIC Light Detector for DVD-ROM/DVD Player (2X Speed)

#### General Description

SHARP's **IS1640** is OPIC light detector for pick-up of DVD-ROM/DVD player which is expected as next generation media. It is also applicable to 2X speed DVD-ROM/DVD player. It has sensitivity switching terminal which enables to read both 1-layer disc and 2-layer disc.

#### Features

- (1) OPIC light detector for RF signal detection  
(Integrates 6-division PIN photodiode and Amp. IC onto a single chip)
- (2) High speed response  
(Response frequency : MIN.20MHz)
- (3) High sensitivity  
(Sensitivity : TYP.40.5mV/ $\mu$ W at 650nm)
- (4) With sensitivity switching terminal which enables to read both 1-layer/2-layer disc
- (5) Compact and thin package  
(Package dimensions : 5.0 x 4.0 x 1.5mm)
- (6) Possible to supply custom-made detecting patterns
- (7) Pair use with SHARP's laser diode is recommended.  
Laser diode : 650nm (self pulsation) **LT055 series**  
650nm **LT056 series**

#### Application

- (1) DVD-ROMs
- (2) DVD players

#### Absolute Maximum Ratings

(Ta=25°C)

Parameter	Symbol	Rating	Unit
Supply voltage	V <sub>CC</sub>	6.0	V
*1 Output voltage	V <sub>O</sub>	V <sub>CC</sub>	V
Operating temperature	T <sub>opr</sub>	-20 to +70	°C
Storage temperature	T <sub>stg</sub>	-40 to +100	°C
*2 Soldering temperature	T <sub>sol</sub>	260	°C

\*1 Applies to V<sub>A</sub> to V<sub>F</sub> terminal.

\*2 For MAX.3s at the position of 1.0mm from the bottom face of resin package.

#### Outline Dimensions

(Unit : mm)

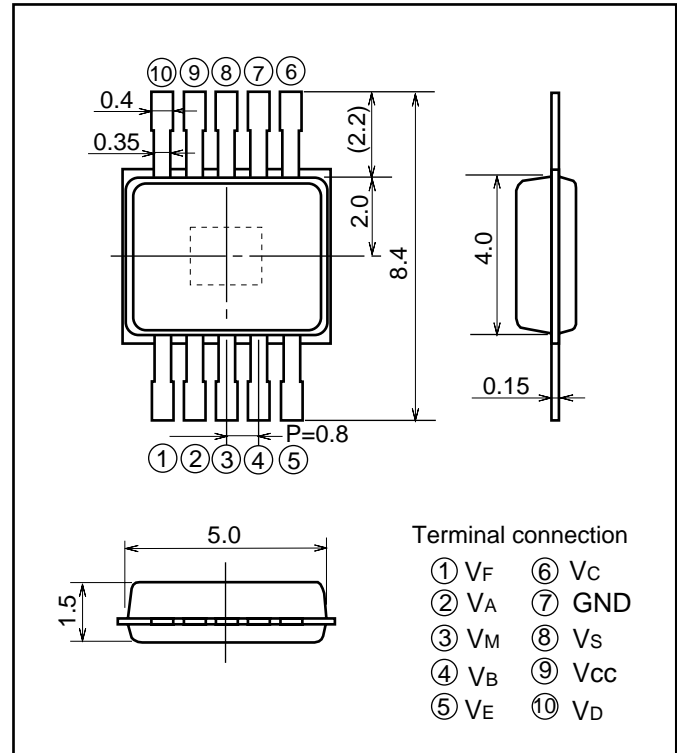

\* "OPIC" (Optical IC) is a trademark of the SHARP Corporation.  
An OPIC consists of a light -detecting element and signal-processing circuit integrated onto a single chip.

(Notice) • In the absence of device specification sheets, SHARP takes no responsibility for any defects that may occur in equipment using any SHARP device shown in catalogs, data books, etc. Contact SHARP in order to obtain the latest device specification sheets before using any SHARP device.  
• Specifications are subject to change without notice for improvement.

(Internet) • Data for SHARP's optoelectronic/power device is provided for internet. (Address <http://www.sharp.co.jp/ecg/>)

### Recommended Operating Conditions

(Ta=25°C)

Parameter	Symbol	Condition	MIN.	TYP.	MAX.	Unit
Supply voltage 1	Vcc	-	4.5	5.0	5.5	V
Supply voltage 2	Vs	-	Vcc/2	Vcc/2	Vcc/2	V

### Electrical Characteristics 1

(Ta=25°C, Vcc=5V, Vs=2.5V)

Parameter	Symbol	Condition	MIN.	TYP.	MAX.	Unit	Application	
H gain mode	Supply current	Icch	-	0.8	6.2	12.4	mA	Vcc
	Output off-set voltage	VodH	Specified by voltage difference from Vs	-15	0	+15	mV	VA to VF
	Extremes of off-set voltage	$\Delta V_{odH}$	A - B	-15	0	+15	mV	VA,VB
			C - D	-15	0	+15		VC,VD
			(A + C) - (B + D)	-15	0	+15		VA to VD
E - F			-15	0	+15	VE,VF		
L gain mode	Supply current	Iccl	-	0.8	6.2	12.4	mA	Vcc
	Output off-set voltage	VodL	Specified by voltage difference from Vs	-15	0	+15	mV	VA to VF
	Extremes of off-set voltage	$\Delta V_{odL}$	A - B	-15	0	+15	mV	VA,VB
			C - D	-15	0	+15		VC,VD
			(A + C) - (B + D)	-15	0	+15		VA to VD
E - F			-15	0	+15	VE,VF		

### Electrical Characteristics 2

(Ta=25°C, Vcc=5V, Vs=2.5V)

Parameter	Symbol	Condition	MIN.	TYP.	MAX.	Unit	Application	
H gain mode	*3,4 Sensitivity 1	RH1	-	30.3	40.5	50.7	mV/ $\mu$ W	VA to VD
	*3,4 Sensitivity 2	RH2	-	43.9	58.6	73.3	mV/ $\mu$ W	VE,VF
	Temperature coefficient of sensitivity	RHt	Ta= - 20°C to + 70°C	-	2 500	-	ppm/°C	VA to VF
	*4,5,6 Response frequency 1	fcH1	- 3dB	20	27	-	MHz	VA to VD
	*4,5,6 Response frequency 2	fcH2	- 3dB	1	1.7	-	MHz	VE,VF
	Output noise level	VnH	f=10MHz,BW=30kHz	-	- 72	- 66	dBm	VA to VD
L gain mode	*3,4 Sensitivity 1	RL1	-	10.1	13.5	16.9	mV/ $\mu$ W	VA to VD
	*3,4 Sensitivity 2	RL2	-	14.6	19.5	24.4	mV/ $\mu$ W	VE,VF
	Temperature coefficient of sensitivity	RLt	Ta= - 20°C to 70°C	-	2 500	-	ppm/°C	VA to VF
	*4,5,6 Response frequency 1	fcL1	- 3dB	20	27	-	MHz	VA to VD
	*4,5,6 Response frequency 2	fcL2	- 3dB	1	1.7	-	MHz	VE,VF
	Output noise level	VnL	f=10MHz,BW=30kHz	-	- 82	- 75	dBm	VA to VD

\*3 10 $\mu$ W,  $\phi$ 30 $\mu$ m of DC light is applied to the center of each photodiode.

Under that condition, sensitivity R is shown by following formula.

$$R = (V_p - V_{od}) / 10\mu W$$

\*4 Light source: laser diode of  $\lambda$ =650nm

\*5 Frequency sensitivity is -3dB.(reference sensitivity : value at f=0.1MHz)

\*6 In addition to 10 $\mu$ W,  $\phi$ 30 $\mu$ W DC light, 4 $\mu$ Wp-p AC light is applied to the center of each photodiode. BW=10kHz

### ■ Block Diagram

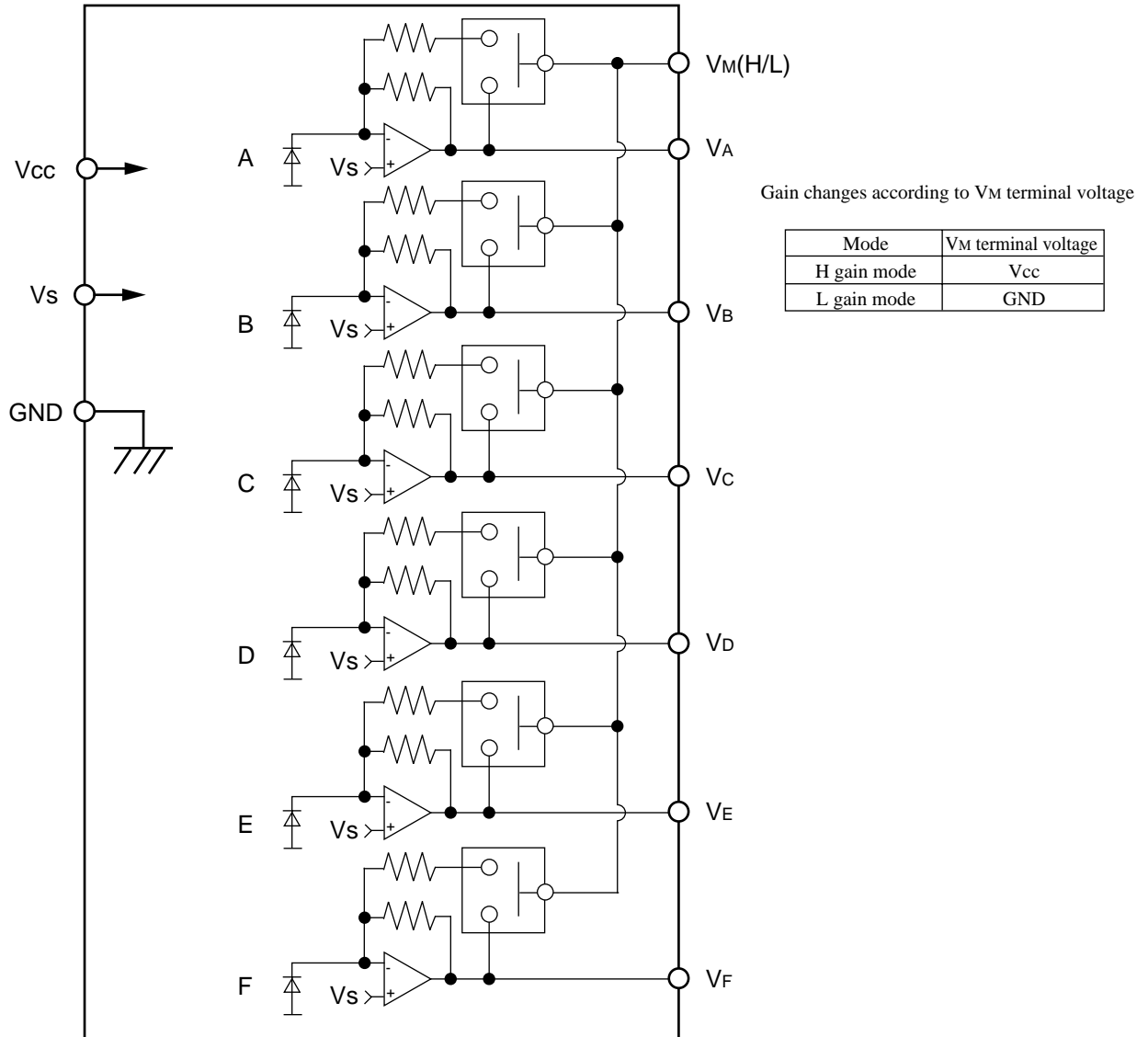

### ■ Detecting Pattern of Photodiode

