

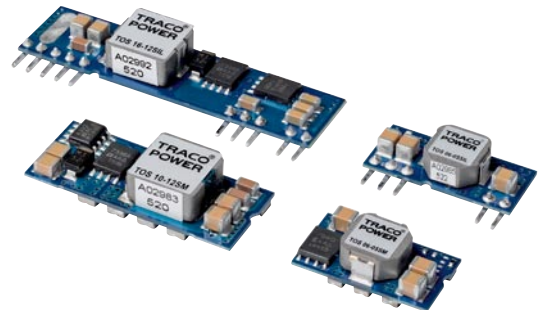

Features

- ◆ Small Size, low Profile
- ◆ SMT package or SIP version
- ◆ Cost-efficient open Frame Design
- ◆ Wide Input Voltage Ranges
- ◆ Output Voltages trim from 0.75VDC to 5.0VDC
- ◆ Delivers up to 16A with minimal derating
- ◆ Ultra high Efficiency to 96%
- ◆ Fast Transient Response
- ◆ Remote On/Off Control
- ◆ Wide Temperature Range(-40°C to 85°C)
- ◆ SMT Package fully DOSA compatible
- ◆ Lead free Design – RoHS compliant



The TOS series is a range of high performance non-isolated dc-dc converters With very high efficiency that can supply up to 16A of output current. These modules provide precisely regulated output voltages which can be set via an external resistor to a value from 0.75 VDC to 5.0VDC. These converters work over a wide input voltage range of 2.4 to 5.5VDC or 8.3 to 14.0VDC. Further features include remote On/Off, under voltage lockout, over temperature and over current protection. These products have an open-frame construction with very small footprint and are available in an industry standard SIP or in a SMT package. The TOS series is fully RoHS compliant and can withstand industry standard handling, cleaning and the high temperatures of lead-free reflow solder processes.

Models

Order code SMT-version	Input voltage range	Output voltage range	Output current max.	Efficiency typ.
TOS 06-05SM	2.4 – 5.5 VDC	0.75 – 3.3 VDC*	6 A	94 %
TOS 10-05SM			10 A	93 %
TOS 16-05SM			16 A	95 %
TOS 06-12SM	8.3 – 14.0 VDC	0.75 – 5.0 VDC	6 A	89 %
TOS 10-12SM			10 A	93 %
TOS 16-12SM			16 A	92 %
SIL-version				
TOS 06-05SIL	2.4 – 5.5 VDC	0.75 – 3.3 VDC*	6 A	94 %
TOS 10-05SIL			10 A	93 %
TOS 16-05SIL			16 A	95 %
TOS 06-12SIL	8.3 – 14 VDC	0.75 – 5.0 VDC	6 A	89 %
TOS 10-12SIL			10 A	93 %
TOS 16-12SIL			16 A	92 %

* Max output voltage to be adjusted min. 0.5 VDC below impressed input voltage

Input Specifications

Input current no load	– Vin 5 VDC (at Vout min./Vout max.)	6 A models: 20 mA / 45 mA typ. 10 A models: 25 mA / 30 mA typ. 16 A models: 25 mA / 40 mA typ.
	– Vin 12 VDC (at Vout min./Vout max.)	6 A models: 17 mA / 100 mA typ. 10 A models: 40 mA / 100 mA typ. 16 A models: 40 mA / 100 mA typ.
Stand by input current (at remote Off)		6 A models: 1 mA typ. 10 A/16 A models: 2 mA typ.
Max. input current	– Vin 5 VDC	6 A models: 6 A 10 A models: 10 A 16 A models: 16 A
	– Vin 12 VDC	6 A models: 4.5 A 10 A models: 7 A 16 A models: 10 A
Start up voltage / under voltage lockout		5 Vin models: 2.2 VDC / 2.0 VDC typ. 12 Vin models: 7.9 VDC / 7.8 VDC typ.
Start up time (power/remote On till Vout set)		8 mS typ.
Reflected ripple current (with input filter)	– Vin 5 VDC	6 A models: 35 mA typ. 10 A / 16 A models: 100 mA typ.
	– Vin 12 VDC	6 A models: 30 mA typ. 10 A models: 20 mA typ. 16 A models: 20 mA typ.
Input filter external (recommended)		2 x 150 µF low ESR polymer capacitors and 2 x 47 µF ceramic capacitors

Output Specifications

Voltage set accuracy		± 2 % max. (see page 3 for set up)
Voltage balance (dual output models)		± 1 % max.
Regulation	– Input variation	± 0.3 % max.
	– Load variation 0 – 100 %	± 0.4 % max.
Dynamic load response max. peak variation / response time	– 50% load change (upper half) with external 1 µF ceramic- and 10 µF tantalum capacitors	
	Vin 5 VDC, 6 A models:	130 mV / 60 µS typ.
	Vin 12 VDC, 6 A models:	200 mV / 35 µS typ.
	Vin 5 VDC, 10 A models:	200 mV / 25 µS typ.
	Vin 12 VDC, 10 A models:	200 mV / 25 µS typ.
	Vin 5 VDC, 16 A models:	300 mV / 25 µS typ.
	Vin 12 VDC, 16 A models:	200 mV / 25 µS typ.
	– 50% load change (upper half) with external 2 x 150 µF polymer capacitors	
	Vin 5 VDC, 6 A models:	50 mV / 100 µS typ.
	Vin 12 VDC, 6 A models:	50 mV / 50 µS typ.
Vin 5 VDC, 10 A models:	100 mV / 100 µS typ.	
Vin 12 VDC, 10 A models:	100 mV / 25 µS typ.	
Vin 5 VDC, 16 A models:	150 mV / 100 µS typ.	
Vin 12 VDC, 16 A models:	100 mV / 50 µS typ.	
Ripple and noise (20 MHz Bandwidth)		5 Vin models: 50 mV pk-pk max. 12 Vin models: 75 mV pk-pk max.
Temperature coefficient		±0.4% typ.
Over current protection		at 200% of Iout max. typ.
Short circuit protection		indefinite, automatic recovery
Capacitive load	– ESR < 1 mOhm	1000 µF max.
	– ESR < 10 mOhm	6 A models: 3000 µF max. 10 A / 16 A models: 5000 µF max.

All specifications valid at nominal input voltage, full load and +25°C after warm-up time unless otherwise stated.

General Specifications

Temperature ranges	- Operating - Storage	-40 °C ... +85 °C -55 °C ... +125 °C
Derating		derating graphs will be published soon. For specific demand ask factory.
Over temperature protection		@ 125°C typ.
Humidity (non condensing)		95 % rel H max.
Reliability, calculated MTBF (Bellcore TR-NWT-000332)	6 A models: 10 A / 16 A models:	>20 mio. h @ 40 °C >14 mio. h @ 40 °C
Switching frequency		300 kHz typ. (pulse width modulation - PWM)
Remote On/Off (reference to GND)		On: 1 VDC ... Vin max. or open circuit. Off: 0 ... 0.3 VDC

Physical Specifications

Weight	6 A models: 10 A / 16 A models:	2.8 g 6 g
Soldering profile	- SIL - Version - SMT - Version	max. 265 °C / 10 sec. (wave soldering) peak temp. 245°C for 10 sec. max., 217°C for 90 sec. max. (Convection reflow solder process is recommended)

Full instruction manual can be downloaded under:
www.tracopower.com/products/tos_application.pdf

Output Voltage Adjustment

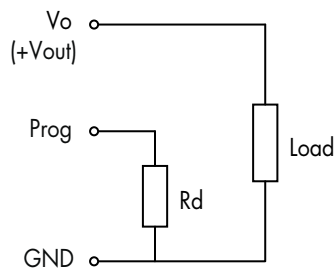

5 VDC input models: $R_d [\text{Ohm}] = \frac{21070}{V_o - 0.7525} - 5110$

12 VDC input models: $R_d [\text{Ohm}] = \frac{10570}{V_o - 0.7525} - 1000$

All specifications valid at nominal input voltage, full load and +25°C after warm-up time unless otherwise stated.

Outline Dimensions mm (inches)

Single-in-Line (SIL-Version)

6 A output Models

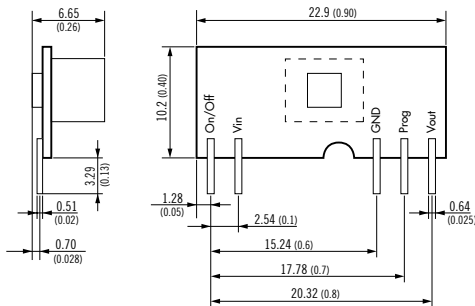

10A & 16A output models

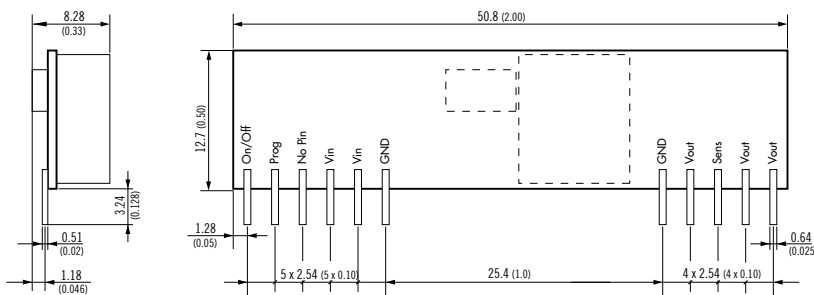

Surface Mount (SMT-Version)

6 A output Models

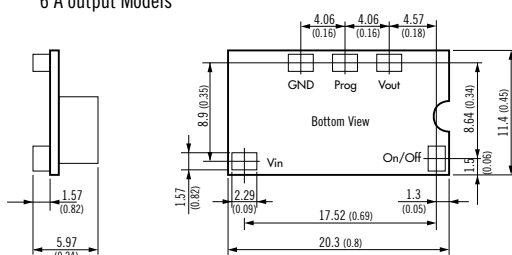

10A & 16A output models

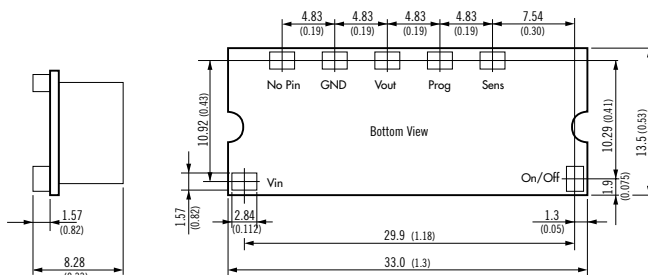

Specifications can be changed any time without notice