

3 TERMINAL LOW DROP VOLTAGE REGULATOR

The KIA78DXXXS/F Series are Low Dropout Voltage Regulator suitable for various electronic equipments.

The Regulator has multi function such as over current protection, overheat protection.

FEATURES

- 1.0A Output Low Drop Voltage Regulator.
- Built in Over Current Protection, Over Heat Protection Function.
- Low Quiescent Current :0.8mA (Typ.)

LINE UP

ITEM	OUTPUT VOLTAGE (Typ.)	UNIT
KIA78D125S/F	1.25	S : SOT-223 F : DPAK
KIA78D015S/F	1.5	
KIA78D018S/F	1.8	
KIA78D020S/F	2.0	
KIA78D025S/F	2.5	
KIA78D030S/F	3.0	
KIA78D033S/F	3.3	
KIA78D050S/F	5.0	

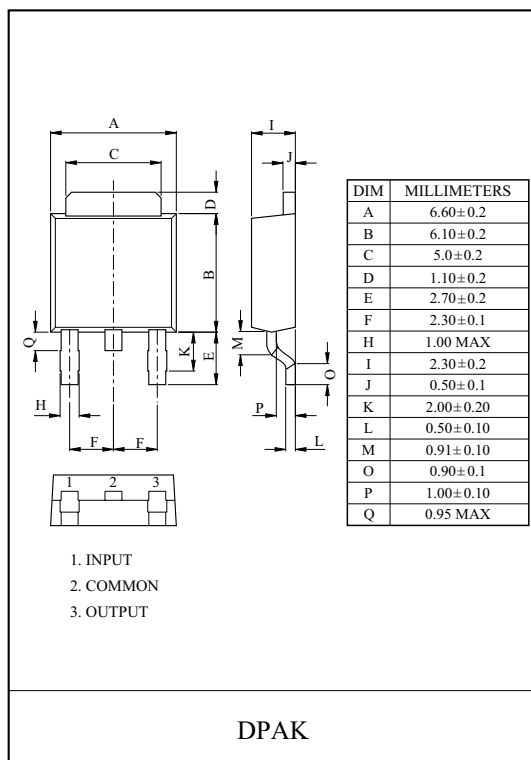
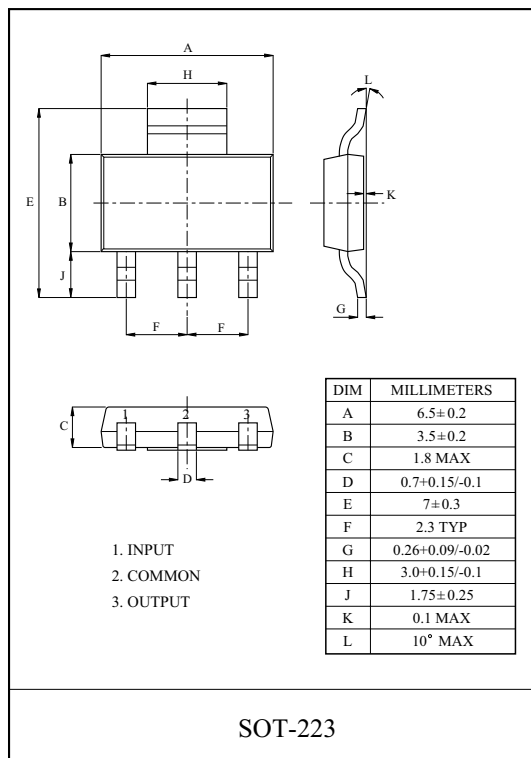

KIA78D125S/F~KIA78D050S/F

MAXIMUM RATINGS (Ta=25 °C)

CHARACTERISTIC		SYMBOL	RATING	UNIT
Input Voltage		V_{IN}	16	V
Output Current		I_{OUT}	1	A
Power Dissipation-1 (No Heatsink)	S (Note)	P_{D1}	1.0	W
	F		1.3	
Power Dissipation-2 (Without Heatsink)	S	P_{D2}	8.3	W
	F		13	
Junction Temperature		T_j	150	°C
Operating Temperature		T_{opr}	-20~80	°C
Storage Temperature		T_{stg}	-30~150	°C
Soldering Temperature		T_{sol}	260	°C

Note) Package Mounted on FR-4 PCB $36 \times 18 \times 1.5$ mm : mounting pad for the GND Lead min. 6cm^2

BLOCK DIAGRAM

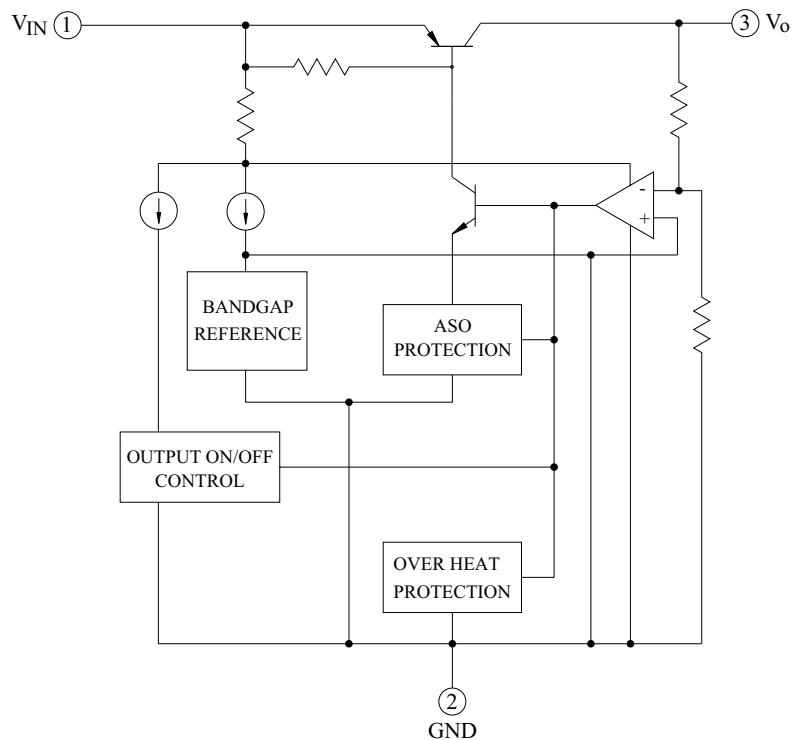

KIA78D125S/F~KIA78D050S/F

ELECTRICAL CHARACTERISTICS

KIA78D125S/F (Unless otherwise specified, $V_{IN}=2.8V$, $T_j=25^\circ C$)

CHARACTERISTIC	SYMBOL	CONDITIONS	MIN.	TYP.	MAX.	UNIT
Output Voltage	V_{OUT}	$V_{IN}=2.8V$, $I_{OUT}=0.5A$	1.225	1.25	1.275	V
		$2.8V \leq V_{IN} \leq 12V$, $5mA \leq I_{OUT} \leq 1A$, $0^\circ C \leq T_j \leq 125^\circ C$	1.21	1.25	1.29	
Line Regulation	Reg Line	$2.8V \leq V_{IN} \leq 12V$, $I_{OUT}=0.5A$	-	5	20	mV
Load Regulation	Reg Load	$V_{IN}=2.8V$, $5mA \leq I_{OUT} \leq 1A$,	-	5	20	mV
Quiescent Current	I_B	$2.8V \leq V_{IN} \leq 12V$, $I_{OUT}=0A$	-	0.8	1.8	mA
		$2.8V \leq V_{IN} \leq 12V$, $I_{OUT}=1A$	-	10	20	
Starting Quiescent Current	I_{Bstart}	$V_{IN}=2.1V$, $I_{OUT}=0A$	-	0.7	5	mA
		$V_{IN}=2.5V$, $I_{OUT}=1A$	-	10	30	
Output Noise Voltage	V_{NO}	$V_{IN}=2.8V$, $I_{OUT}=50mA$, $10Hz \leq f \leq 100kHz$	-	110	-	μV_{rms}
Ripple Rejection	$R \cdot R$	$2.8V \leq V_{IN} \leq 12V$, $I_{OUT}=50mA$, $f=120Hz$	53	65	-	dB
Dropout Voltage	V_D	$I_{OUT}=0.5A$	-	0.3	0.5	V
		$I_{OUT}=1A$	-	0.5	-	

ELECTRICAL CHARACTERISTICS

KIA78D015S/F (Unless otherwise specified, $V_{IN}=3.8V$, $T_j=25^\circ C$)

CHARACTERISTIC	SYMBOL	CONDITIONS	MIN.	TYP.	MAX.	UNIT
Output Voltage	V_{OUT}	$V_{IN}=3.8V$, $I_{OUT}=0.5A$	1.45	1.5	1.55	V
		$2.8V \leq V_{IN} \leq 12V$, $5mA \leq I_{OUT} \leq 1A$, $0^\circ C \leq T_j \leq 125^\circ C$	1.434	1.5	1.566	
Line Regulation	Reg Line	$2.8V \leq V_{IN} \leq 12V$, $I_{OUT}=0.5A$	-	5	20	mV
Load Regulation	Reg Load	$V_{IN}=3.8V$, $5mA \leq I_{OUT} \leq 1A$,	-	5	20	mV
Quiescent Current	I_B	$2.8V \leq V_{IN} \leq 12V$, $I_{OUT}=0A$	-	0.8	1.8	mA
		$2.8V \leq V_{IN} \leq 12V$, $I_{OUT}=1A$	-	10	20	
Starting Quiescent Current	I_{Bstart}	$V_{IN}=2.1V$, $I_{OUT}=0A$	-	0.7	5	mA
		$V_{IN}=2.5V$, $I_{OUT}=1A$	-	10	30	
Output Noise Voltage	V_{NO}	$V_{IN}=3.8V$, $I_{OUT}=50mA$, $10Hz \leq f \leq 100kHz$	-	75	-	μV_{rms}
Ripple Rejection	$R \cdot R$	$2.8V \leq V_{IN} \leq 12V$, $I_{OUT}=50mA$, $f=120Hz$	53	65	-	dB
Dropout Voltage	V_D	$I_{OUT}=0.5A$	-	0.5	0.7	V
		$I_{OUT}=1A$	-	0.6	-	

KIA78D125S/F~KIA78D050S/F

ELECTRICAL CHARACTERISTICS

KIA78D018S/F (Unless otherwise specified, $V_{IN}=3.8V$, $T_j=25^\circ C$)

CHARACTERISTIC	SYMBOL	CONDITIONS	MIN.	TYP.	MAX.	UNIT
Output Voltage	V_{OUT}	$V_{IN}=3.8V$, $I_{OUT}=0.5A$	1.75	1.8	1.85	V
		$2.8V \leq V_{IN} \leq 12V$, $5mA \leq I_{OUT} \leq 1A$, $0^\circ C \leq T_j \leq 125^\circ C$	1.732	1.8	1.868	
Line Regulation	Reg Line	$2.8V \leq V_{IN} \leq 12V$, $I_{OUT}=0.5A$	-	5	20	mV
Load Regulation	Reg Load	$V_{IN}=3.8V$, $5mA \leq I_{OUT} \leq 1A$,	-	5	20	mV
Quiescent Current	I_B	$2.8V \leq V_{IN} \leq 12V$, $I_{OUT}=0A$	-	0.8	1.8	mA
		$2.8V \leq V_{IN} \leq 12V$, $I_{OUT}=1A$	-	10	20	
Starting Quiescent Current	I_{Bstart}	$V_{IN}=2.1V$, $I_{OUT}=0A$	-	0.7	5	mA
		$V_{IN}=2.5V$, $I_{OUT}=1A$	-	10	30	
Output Noise Voltage	V_{NO}	$V_{IN}=3.8V$, $I_{OUT}=50mA$, $10Hz \leq f \leq 100kHz$	-	75	-	μV_{rms}
Ripple Rejection	$R \cdot R$	$2.8V \leq V_{IN} \leq 12V$, $I_{OUT}=50mA$, $f=120Hz$	53	65	-	dB
Dropout Voltage	V_D	$I_{OUT}=0.5A$	-	0.3	0.5	V
		$I_{OUT}=1A$	-	0.5	-	

ELECTRICAL CHARACTERISTICS

KIA78D020S/F (Unless otherwise specified, $V_{IN}=4V$, $T_j=25^\circ C$)

CHARACTERISTIC	SYMBOL	CONDITIONS	MIN.	TYP.	MAX.	UNIT
Output Voltage	V_{OUT}	$V_{IN}=4V$, $I_{OUT}=0.5A$	1.95	2.0	2.05	V
		$3V \leq V_{IN} \leq 12V$, $5mA \leq I_{OUT} \leq 1A$, $0^\circ C \leq T_j \leq 125^\circ C$	1.93	2.0	2.07	
Line Regulation	Reg Line	$3.0V \leq V_{IN} \leq 12V$, $I_{OUT}=0.5A$	-	5	20	mV
Load Regulation	Reg Load	$V_{IN}=4V$, $5mA \leq I_{OUT} \leq 1A$,	-	5	20	mV
Quiescent Current	I_B	$3.0V \leq V_{IN} \leq 12V$, $I_{OUT}=0A$	-	0.8	1.8	mA
		$3.0V \leq V_{IN} \leq 12V$, $I_{OUT}=1A$	-	10	20	
Starting Quiescent Current	I_{Bstart}	$V_{IN}=2.1V$, $I_{OUT}=0A$	-	0.7	5	mA
		$V_{IN}=2.5V$, $I_{OUT}=1A$	-	10	30	
Output Noise Voltage	V_{NO}	$V_{IN}=4V$, $I_{OUT}=50mA$, $10Hz \leq f \leq 100kHz$	-	80	-	μV_{rms}
Ripple Rejection	$R \cdot R$	$3.0V \leq V_{IN} \leq 12V$, $I_{OUT}=50mA$, $f=120Hz$	52	65	-	dB
Dropout Voltage	V_D	$I_{OUT}=0.5A$	-	0.3	0.5	V
		$I_{OUT}=1A$	-	0.5	-	

KIA78D125S/F~KIA78D050S/F

ELECTRICAL CHARACTERISTICS

KIA78D025S/F (Unless otherwise specified, $V_{IN}=4.5V$, $T_j=25^\circ C$)

CHARACTERISTIC	SYMBOL	CONDITIONS	MIN.	TYP.	MAX.	UNIT
Output Voltage	V_{OUT}	$V_{IN}=4.5V$, $I_{OUT}=0.5A$	2.438	2.5	2.562	V
		$3.5V \leq V_{IN} \leq 12V$, $5mA \leq I_{OUT} \leq 1A$, $0^\circ C \leq T_j \leq 125^\circ C$	2.412	2.5	2.588	
Line Regulation	Reg Line	$3.5V \leq V_{IN} \leq 12V$, $I_{OUT}=0.5A$	-	5	20	mV
Load Regulation	Reg Load	$V_{IN}=4.5V$, $5mA \leq I_{OUT} \leq 1A$,	-	5	20	mV
Quiescent Current	I_B	$3.5V \leq V_{IN} \leq 12V$, $I_{OUT}=0A$	-	0.8	1.8	mA
		$3.5V \leq V_{IN} \leq 12V$, $I_{OUT}=1A$	-	10	20	
Starting Quiescent Current	I_{Bstart}	$V_{IN}=2.1V$, $I_{OUT}=0A$	-	0.9	5	mA
		$V_{IN}=2.7V$, $I_{OUT}=1A$	-	12	30	
Output Noise Voltage	V_{NO}	$V_{IN}=4.5V$, $I_{OUT}=50mA$, $10Hz \leq f \leq 100kHz$	-	95	-	μV_{rms}
Ripple Rejection	$R \cdot R$	$3.5V \leq V_{IN} \leq 12V$, $I_{OUT}=50mA$, $f=120Hz$	53	64	-	dB
Dropout Voltage	V_D	$I_{OUT}=0.5A$	-	0.3	0.5	V
		$I_{OUT}=1A$	-	0.5	-	

ELECTRICAL CHARACTERISTICS

KIA78D030S/F (Unless otherwise specified, $V_{IN}=5V$, $T_j=25^\circ C$)

CHARACTERISTIC	SYMBOL	CONDITIONS	MIN.	TYP.	MAX.	UNIT
Output Voltage	V_{OUT}	$V_{IN}=5.0V$, $I_{OUT}=0.5A$	2.925	3.0	3.075	V
		$4.0V \leq V_{IN} \leq 12V$, $5mA \leq I_{OUT} \leq 1A$, $0^\circ C \leq T_j \leq 125^\circ C$	2.895	3.0	3.105	
Line Regulation	Reg Line	$4.0V \leq V_{IN} \leq 12V$, $I_{OUT}=0.5A$	-	5	20	mV
Load Regulation	Reg Load	$V_{IN}=5.0V$, $5mA \leq I_{OUT} \leq 1A$,	-	5	20	mV
Quiescent Current	I_B	$4.0V \leq V_{IN} \leq 12V$, $I_{OUT}=0A$	-	0.8	1.8	mA
		$4.0V \leq V_{IN} \leq 12V$, $I_{OUT}=1A$	-	10	20	
Starting Quiescent Current	I_{Bstart}	$V_{IN}=2.1V$, $I_{OUT}=0A$	-	1.1	5	mA
		$V_{IN}=2.8V$, $I_{OUT}=1A$	-	13	30	
Output Noise Voltage	V_{NO}	$V_{IN}=5.0V$, $I_{OUT}=50mA$, $10Hz \leq f \leq 100kHz$	-	110	-	μV_{rms}
Ripple Rejection	$R \cdot R$	$4.0V \leq V_{IN} \leq 12V$, $I_{OUT}=50mA$, $f=120Hz$	50	63	-	dB
Dropout Voltage	V_D	$I_{OUT}=0.5A$	-	0.3	0.5	V
		$I_{OUT}=1A$	-	0.5	-	

KIA78D125S/F~KIA78D050S/F

ELECTRICAL CHARACTERISTICS

KIA78D033S/F (Unless otherwise specified, $V_{IN}=5.3V$, $T_j=25^\circ C$)

CHARACTERISTIC	SYMBOL	CONDITIONS	MIN.	TYP.	MAX.	UNIT
Output Voltage	V_{OUT}	$V_{IN}=5.3V$, $I_{OUT}=0.5A$	3.218	3.3	3.382	V
		$4.3V \leq V_{IN} \leq 12V$, $5mA \leq I_{OUT} \leq 1A$, $0^\circ C \leq T_j \leq 125^\circ C$	3.184	3.3	3.416	
Line Regulation	Reg Line	$4.3V \leq V_{IN} \leq 12V$, $I_{OUT}=0.5A$	-	5	20	mV
Load Regulation	Reg Load	$V_{IN}=5.3V$, $5mA \leq I_{OUT} \leq 1A$,	-	5	20	mV
Quiescent Current	I_B	$4.3V \leq V_{IN} \leq 12V$, $I_{OUT}=0A$	-	0.8	1.8	mA
		$4.3V \leq V_{IN} \leq 12V$, $I_{OUT}=1A$	-	10	20	
Starting Quiescent Current	I_{Bstart}	$V_{IN}=2.1V$, $I_{OUT}=0A$	-	1.1	5	mA
		$V_{IN}=2.9V$, $I_{OUT}=1A$	-	13	30	
Output Noise Voltage	V_{NO}	$V_{IN}=5.3V$, $I_{OUT}=50mA$, $10Hz \leq f \leq 100kHz$	-	115	-	μV_{rms}
Ripple Rejection	$R \cdot R$	$4.3V \leq V_{IN} \leq 12V$, $I_{OUT}=50mA$, $f=120Hz$	48	61	-	dB
Dropout Voltage	V_D	$I_{OUT}=0.5A$	-	0.3	0.5	V
		$I_{OUT}=1A$	-	0.5	-	

ELECTRICAL CHARACTERISTICS

KIA78D050S/F (Unless otherwise specified, $V_{IN}=7V$, $T_j=25^\circ C$)

CHARACTERISTIC	SYMBOL	CONDITIONS	MIN.	TYP.	MAX.	UNIT
Output Voltage	V_{OUT}	$V_{IN}=7V$, $I_{OUT}=0.5A$	4.88	5.0	5.12	V
		$6.0V \leq V_{IN} \leq 12V$, $5mA \leq I_{OUT} \leq 1A$, $0^\circ C \leq T_j \leq 125^\circ C$	4.83	5.0	5.17	
Line Regulation	Reg Line	$6.0V \leq V_{IN} \leq 12V$, $I_{OUT}=0.5A$	-	5	20	mV
Load Regulation	Reg Load	$V_{IN}=7.0V$, $5mA \leq I_{OUT} \leq 1A$,	-	5	20	mV
Quiescent Current	I_B	$6.0V \leq V_{IN} \leq 12V$, $I_{OUT}=0A$	-	0.8	1.8	mA
		$6.0V \leq V_{IN} \leq 12V$, $I_{OUT}=1A$	-	10	20	
Starting Quiescent Current	I_{Bstart}	$V_{IN}=2.1V$, $I_{OUT}=0A$	-	1.3	5	mA
		$V_{IN}=3.0V$, $I_{OUT}=1A$	-	14	30	
Output Noise Voltage	V_{NO}	$V_{IN}=7.0V$, $I_{OUT}=50mA$, $10Hz \leq f \leq 100kHz$	-	150	-	μV_{rms}
Ripple Rejection	$R \cdot R$	$6.0V \leq V_{IN} \leq 12V$, $I_{OUT}=50mA$, $f=120Hz$	48	60	-	dB
Dropout Voltage	V_D	$I_{OUT}=0.5A$	-	0.3	0.5	V
		$I_{OUT}=1A$	-	0.5	-	

KIA78D125S/F~KIA78D050S/F

Fig. 1 Standard Test Circuit

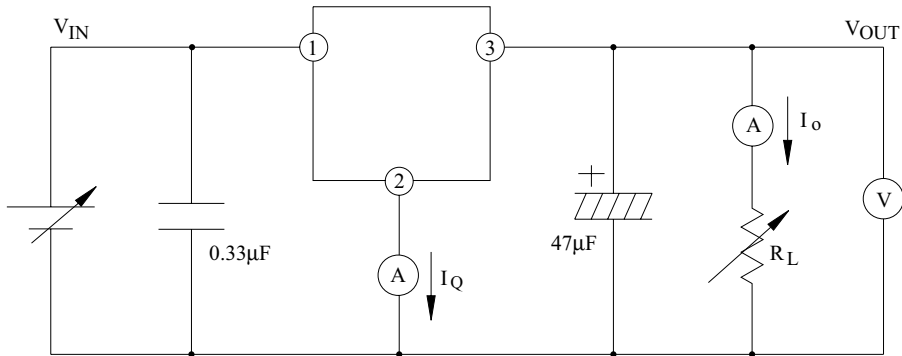

Fig. 2 Ripple Rejection Test Circuit

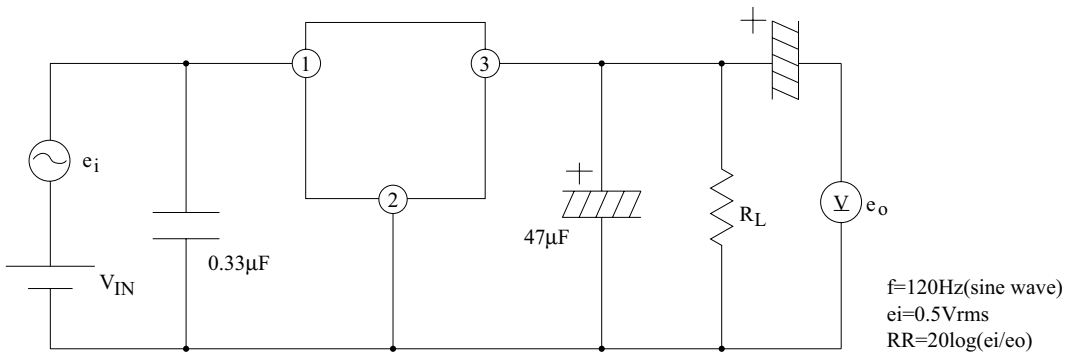
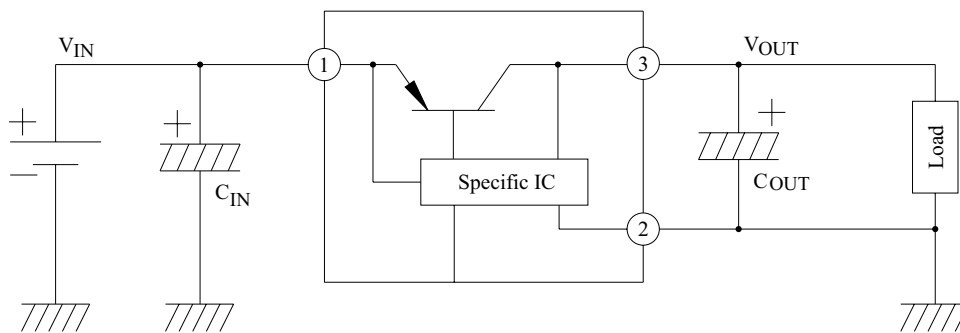

Fig. 3 Application Circuit for Standard



KIA78D125S/F~KIA78D050S/F

Fig. 4 $V_{OUT} - T_j$

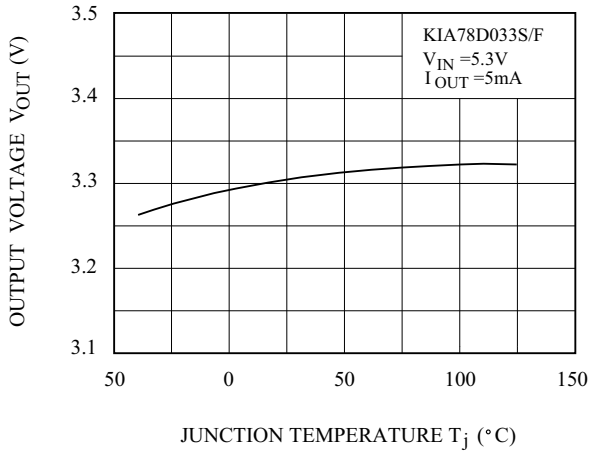

Fig. 5 $V_{OUT} - V_{IN}$

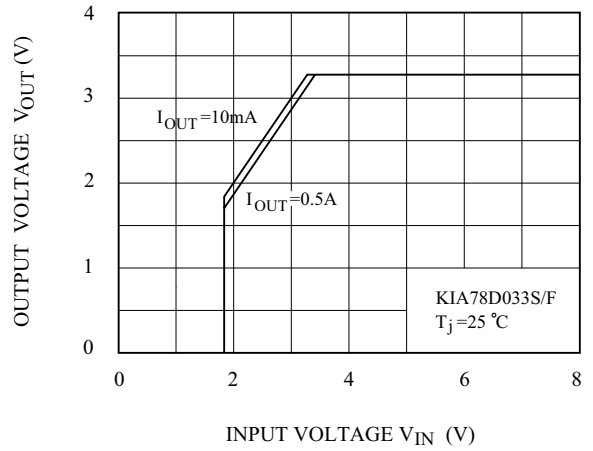

Fig. 6 $I_B - V_{IN}$

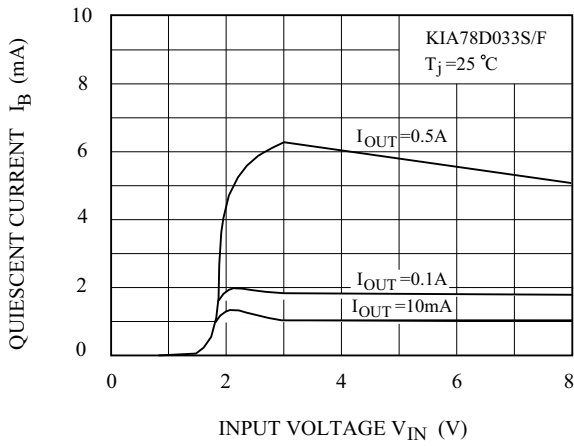

Fig. 7 $I_B - T_j$

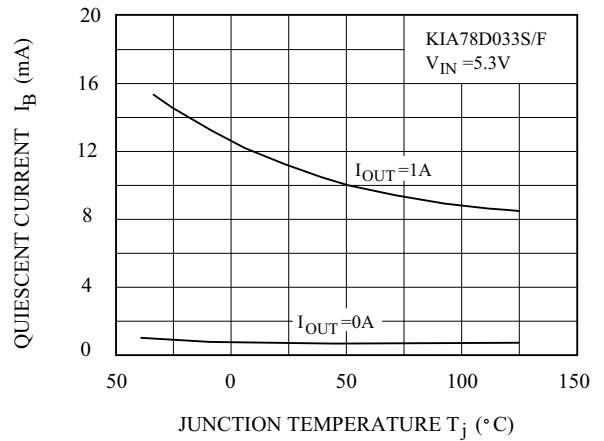

Fig. 8 $I_B - I_{OUT}$

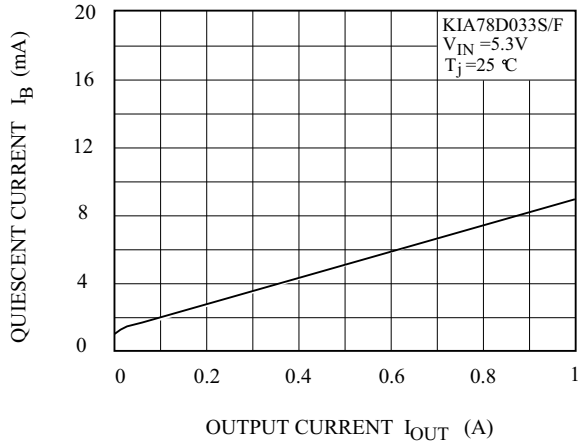
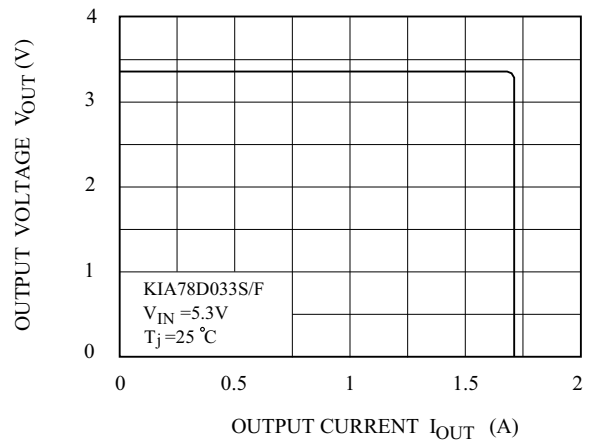

Fig. 9 $V_{OUT} - I_{OUT}$



KIA78D125S/F~KIA78D050S/F

Fig.10 $V_D - T_j$

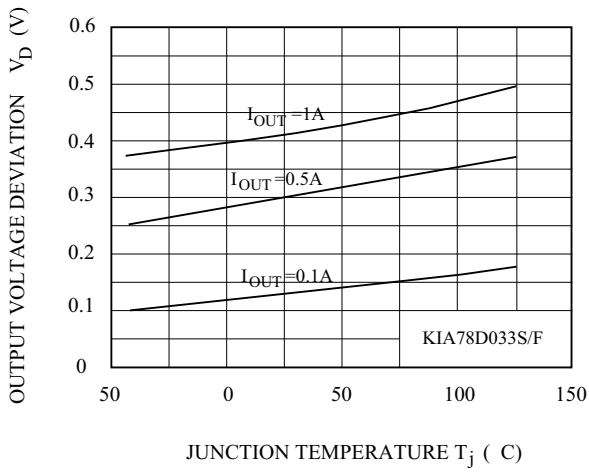

Fig.11 RR-f

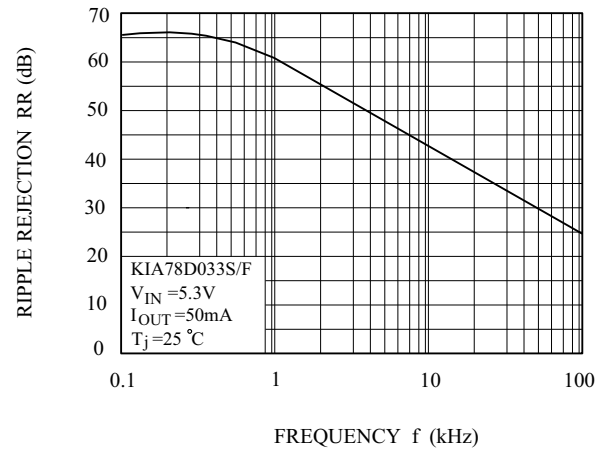

Fig.12 $P_D - T_a$ (S-Type : SOT-223)

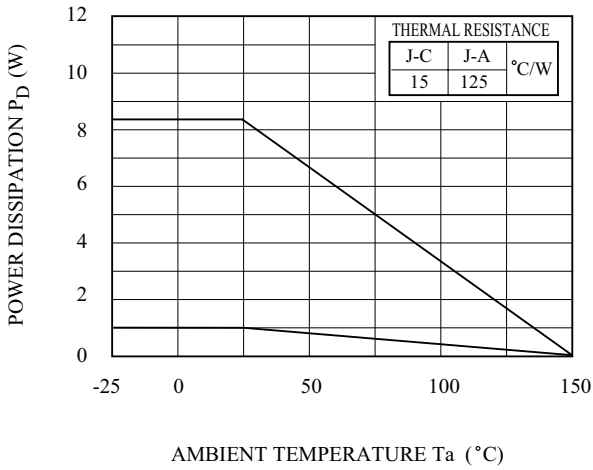

Fig.13 $P_D - T_a$ (F-Type : DPAK)

