



Product Description

The Stanford Microdevices' STM-2016 is a high linearity active mixer for use in a wide variety of communication systems covering the 1800-2200 MHz frequency bands. This device operates from a single 5V supply and provides 9dB of conversion gain while requiring only 0dBm input to the integrated LO driver. The STM-2016 also includes an integrated on chip IF amplifier and is fabricated using silicon germanium device technology.

The STM-2016 incorporates internal matching on each RF, IF, and LO port to enhance ease of use and to reduce the number of external components required. The IF and LO ports can be driven differential or single ended. Each broadband port has been designed to minimize performance degradation while operating into highly reactive components such as SAW filters.

Functional Block Diagram

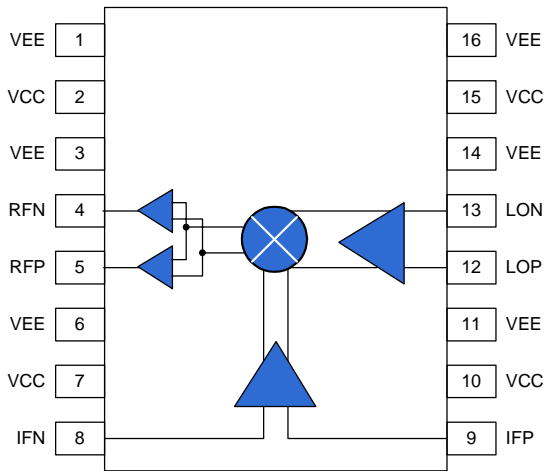

Key Specifications

Parameters	Test Conditions ($V_{CC}=5.0V$, $I=190mA$, $T=25^{\circ}C$)	Unit	Min.	Typ.	Max.
RF Frequency Range		MHz	1800		2200
IF Frequency Range		MHz	10	200	300
Output IP3	IF1 = IF2 = -20 dBm/tone	dBm		+15	
Output P1dB		dBm		+3.5	
Conversion Gain		dB		9	
SSB Noise Figure		dB		9	

The information provided herein is believed to be reliable at press time. Stanford Microdevices assumes no responsibility for inaccuracies or omissions. Stanford Microdevices assumes no responsibility for the use of this information, and all such information shall be entirely at the user's own risk. Prices and specifications are subject to change without notice. No patent rights or licenses to any of the circuits described herein are implied or granted to any third party. Stanford Microdevices does not authorize or warrant any Stanford Microdevices product for use in life-support devices and/or systems.

Copyright 2000 Stanford Microdevices, Inc. All worldwide rights reserved.

522 Almanor Ave., Sunnyvale, CA 94086

Phone: (800) SMI-MMIC

<http://www.stanfordmicro.com>

STM-2016

1800 - 2200 MHz High Linearity
Silicon Germanium
Active Transmit Mixer



16 pin TSSOP with Exposed Pad
Package Body: 0.20 x 0.17 x 0.04 (inches)
5.0 x 4.4 x 1.0 (mm)

Product Features

- Active mixer with conversion gain
- No need for separate external LO driver
- Low LO drive level required to drive mixer
- IF and LO ports may be driven single-ended
- Single supply operation (+5V)
- Broadband resistive 50Ω impedances on all three ports

Applications

- Digital and spread spectrum communication systems
- 1800-2200 MHz transceivers for base station infrastructure equipment



Advanced Data Sheet
STM-2016 1800-2200 MHz Transmit Mixer

Absolute Maximum Ratings

Parameters	Value	Unit
Supply Voltage	+6.0	V _{DC}
LO Input	+10	dBm
RF Input	+15	dBm
Operating Temperature	-40 to +85	°C
Storage Temperature	-65 to +150	°C

Test Conditions

VCC	+5.0V
TA	+25°C
IF Input	-20 dBm @ 200 MHz
LO Input	0 dBm @ 1760 MHz

Product Specifications – AC Performance

Parameters	Additional Test Conditions	Unit	Min.	Typ.	Max.
RF Frequency Range		MHz	1800		2200
IF Frequency Range		MHz	10	200	300
Output IP3	IF1 = IF2 = -20 dBm/tone	dBm		+15	
Output P1dB		dBm		+3.5	
Conversion Gain		dB		9	
SSB Noise figure		dB		9	
RF Return Loss		dB		14	
LO Return Loss		dB		14	
IF Return Loss		dB		14	
LO Drive		dBm	-3	0	+3

Product Specifications – Isolation Performance

Parameters	Additional Test Conditions	Unit	Min.	Typ.	Max.
Leakage (LO-RF)		dBm		-25	
Leakage (LO-IF)		dBm		-30	

Product Specifications – Miscellaneous

Parameters	Additional Test Conditions	Unit	Min.	Typ.	Max.
Supply Voltage		V	+4.75	+5.0	+5.25
Supply Current		mA		190	
Thermal Resistance		°C/W		TBD	

The information provided herein is believed to be reliable at press time. Stanford Microdevices assumes no responsibility for inaccuracies or omissions. Stanford Microdevices assumes no responsibility for the use of this information, and all such information shall be entirely at the user's own risk. Prices and specifications are subject to change without notice. No patent rights or licenses to any of the circuits described herein are implied or granted to any third party. Stanford Microdevices does not authorize or warrant any Stanford Microdevices product for use in life-support devices and/or systems.
Copyright 2000 Stanford Microdevices, Inc. All worldwide rights reserved.
522 Almanor Ave., Sunnyvale, CA 94086 Phone: (800) SMI-MMIC <http://www.stanfordmicro.com>
2 05/04/01 rev 1.0

Typical Device Performance

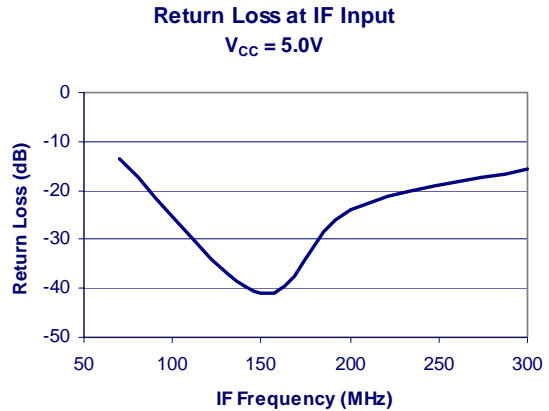
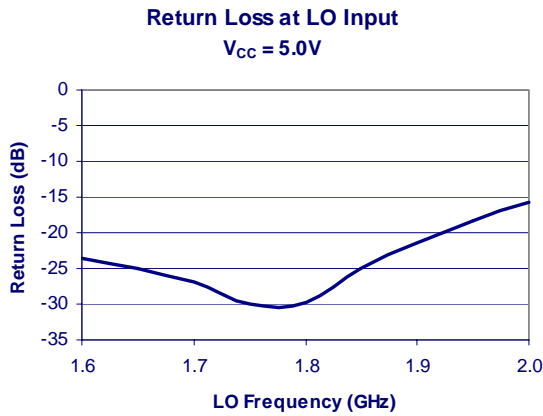
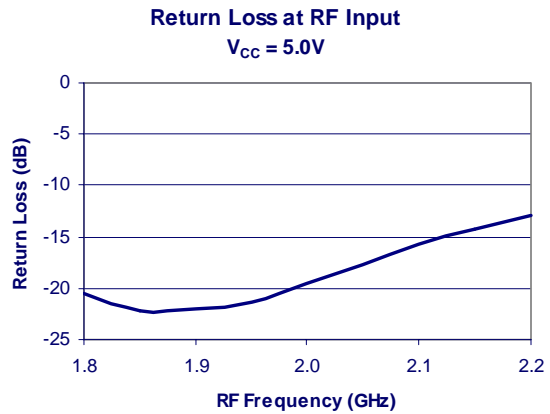
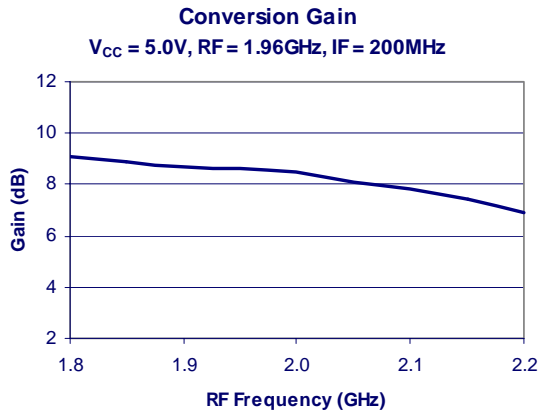

NOTE: The data shown in the graphs above demonstrates the STM-2016 performance tuned to the PCS band.



Advanced Data Sheet
STM-2016 1800-2200 MHz Transmit Mixer

Pin Out Description

Pin #	Function	Description	Additional Comments
1	VEE	Ground	
2	VCC	Positive supply (+5V)	
3	VEE	Ground	
4	RFN	RF input, negative terminal	Nominal DC voltage is 2.3V. (Internally biased) Output should be AC-coupled.
5	RFP	RF input, positive terminal	Nominal DC voltage is 2.3V. (Internally biased) Output should be AC-coupled.
6	VEE	Ground	
7	VCC	Positive supply (+5V)	
8	IFN	IF output, negative terminal	Nominal DC voltage is 2.2V. (Internally biased) Input should be AC-coupled
9	IFP	IF output, positive terminal	Nominal DC voltage is 2.2V. (Internally biased) Input should be AC-coupled
10	VCC	Positive supply (+5V)	
11	VEE	Ground	
12	LOP	LO input, positive terminal	Nominal DC voltage is 2.3V. (Internally biased) Input should be AC-coupled.
13	LON	LO input, negative terminal	Nominal DC voltage is 2.3V. (Internally biased) Input should be AC-coupled.
14	VEE	Ground	
15	VCC	Positive supply (+5V)	
16	VEE	Ground	



Caution: ESD Sensitive
 Appropriate precaution in handling, packaging and testing devices must be observed.

Part Number Ordering Information

Part Number	Reel Size	Devices/Reel
STM-2016	TBD	TBD

Part Symbolization

The part will be symbolized with a "TBD" marking designator on the top surface of the package.

Package Dimensions ("16" Package)

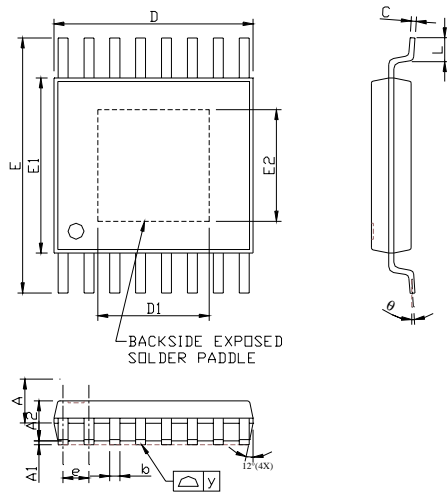

- NOTE
1. PACKAGE BODY SIZES EXCLUDE MOLD FLASH PROTRUSIONS OR GATE BURRS
 2. TOLERANCE ± 0.1 mm UNLESS OTHERWISE SPECIFIED
 3. COPLANARITY : 0.1 mm
 4. CONTROLLING DIMENSION IS MILLIMETER. CONVERTED INCH DIMENSIONS ARE NOT NECESSARILY EXACT.
 5. FOLLOWED FROM JEDEC MO-153

SYMBOLS	DIMENSIONS IN MILLIMETERS			DIMENSIONS IN INCHES		
	MIN	NOM	MAX	MIN	NOM	MAX
A	—	—	1.15	—	—	0.045
A1	0.00	—	0.10	0.000	—	0.004
A2	0.80	1.00	1.05	0.031	0.039	0.041
b	0.19	—	0.30	0.007	—	0.012
C	0.09	—	0.20	0.004	—	0.008
D	4.90	5.00	5.10	0.193	0.197	0.201
D1	—	2.80	—	—	0.110	—
E	—	6.40	—	—	0.252	—
E1	4.30	4.40	4.50	0.169	0.173	0.177
E2	—	2.80	—	—	0.110	—
e	—	0.65	—	—	0.026	—
L	0.45	0.60	0.75	0.018	0.024	0.030
y	—	—	0.10	—	—	0.004
θ	0°	—	8°	0°	—	8°

Test PCB Pad Layout

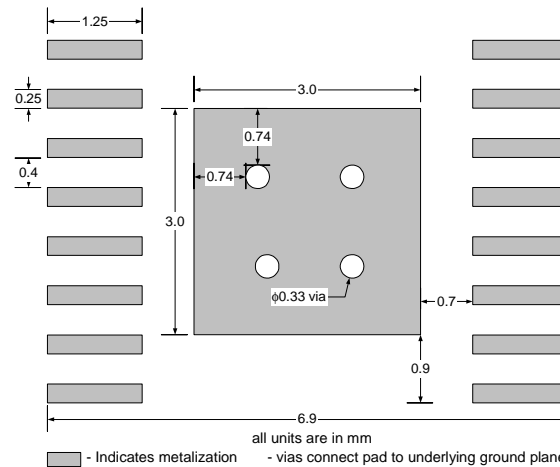

The information provided herein is believed to be reliable at press time. Stanford Microdevices assumes no responsibility for inaccuracies or omissions. Stanford Microdevices assumes no responsibility for the use of this information, and all such information shall be entirely at the user's own risk. Prices and specifications are subject to change without notice. No patent rights or licenses to any of the circuits described herein are implied or granted to any third party. Stanford Microdevices does not authorize or warrant any Stanford Microdevices product for use in life-support devices and/or systems. Copyright 2000 Stanford Microdevices, Inc. All worldwide rights reserved. 522 Almanor Ave., Sunnyvale, CA 94086 Phone: (800) SMI-MMIC 5 <http://www.stanfordmicro.com> 05/04/01 rev 1.0

Demo Test Board Schematic

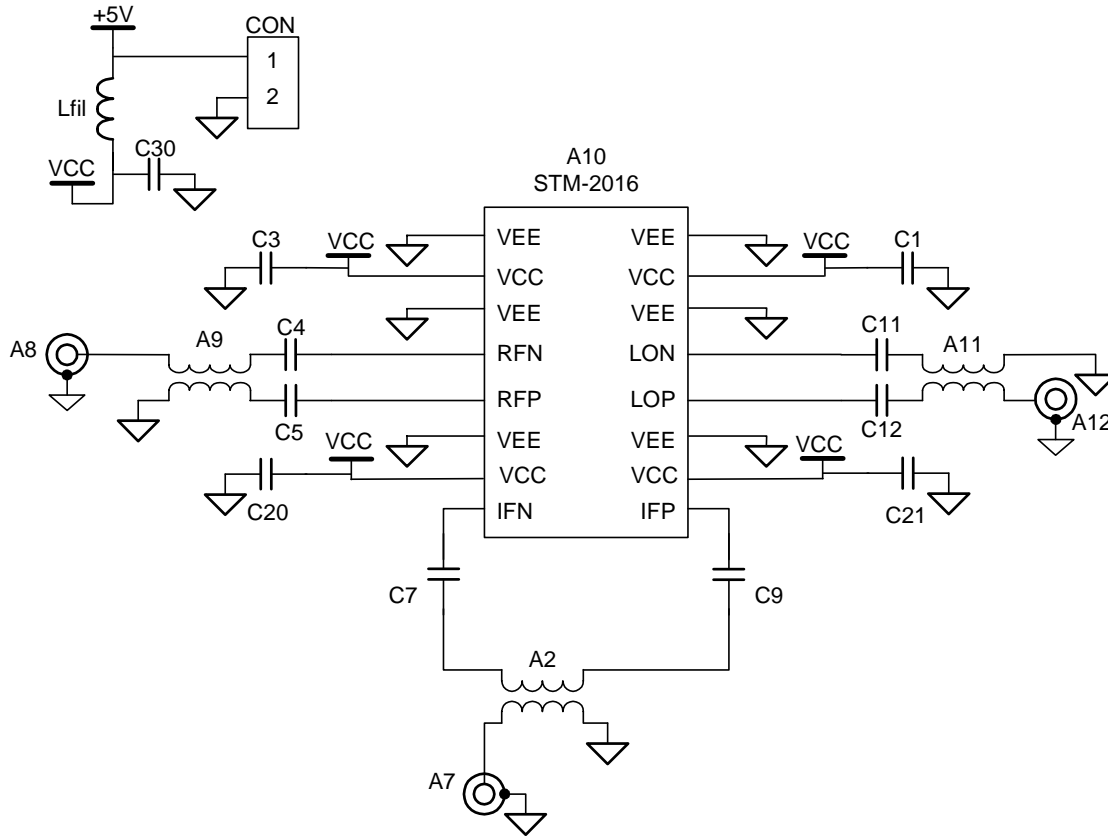

Bill of Materials

Component Designator	Value	Qty	Vendor	Part Number	Description
A10		1	SMDI	STM-2016	SiGe Transmit Mixer
A7, A8, A12		3	Johnson Components	142-0701-851	SMA connector, end launch with tab, for 62 mil pitch thick board
CON		1	Digikey	S1212-36-ND	2-pin header
A9, A11	1:1	2	Panasonic	EHF-FD1619	RF transformer
A2	1:1	1	Mini-Circuits	TC1-1	IF transformer
Lfil	1uH	1	Digikey	PCD1008CT-ND	Inductor, 1210 footprint, min. 200mA rating
C1, C3, C20, C21, C30	6.8pF	5	Venkel	C0603COG500-6R8CNE	Capacitor, 0603 footprint
C7, C9	100pF	2	Venkel	C0603COG500-101JNE	Capacitor, 0603 footprint
C4, C5	2.2pF	2	Venkel	C0603COG500-2R2CNE	Capacitor, 0603 footprint
C11, C12	4.7pF	2	Venkel	C0603COG500-4R7CNE	Capacitor, 0603 footprint

The information provided herein is believed to be reliable at press time. Stanford Microdevices assumes no responsibility for inaccuracies or omissions. Stanford Microdevices assumes no responsibility for the use of this information, and all such information shall be entirely at the user's own risk. Prices and specifications are subject to change without notice. No patent rights or licenses to any of the circuits described herein are implied or granted to any third party. Stanford Microdevices does not authorize or warrant any Stanford Microdevices product for use in life-support devices and/or systems.

Copyright 2000 Stanford Microdevices, Inc. All worldwide rights reserved.
522 Almanor Ave., Sunnyvale, CA 94086

Phone: (800) SMI-MMIC
6

<http://www.stanfordmicro.com>
05/04/01 rev 1.0

**Demo Test Board
(Fully Assembled PCB)**

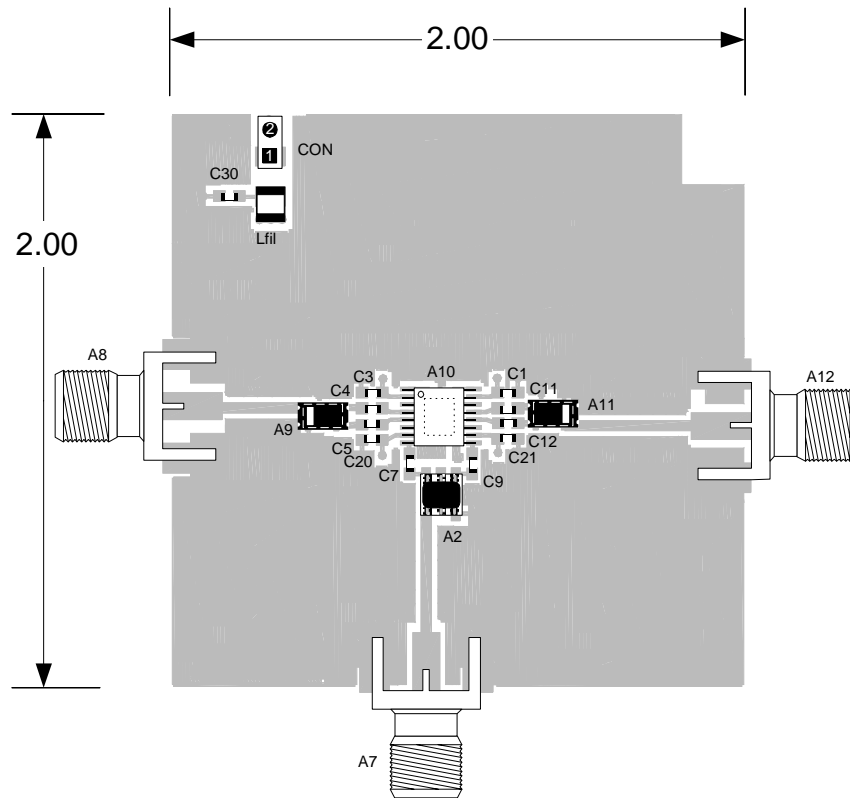

Note: Dimensions in inches