



LM117/LM217/LM317

1.2V to 37V Adjustable voltage regulators

Feature summary

- Output voltage range: 1.2 to 37V
- Output current in excess of 1.5A
- 0.1% Line and load regulation
- Floating operation for high voltages
- Complete series of protections: current limiting, thermal shutdown and SOA control

Description

The LM117/LM217/LM317 are monolithic integrated circuit in TO-220, TO-220FP, TO-3 and D²PAK packages intended for use as positive adjustable voltage regulators.

They are designed to supply more than 1.5A of load current with an output voltage adjustable over a 1.2 to 37V range.

The nominal output voltage is selected by means of only a resistive divider, making the device exceptionally easy to use and eliminating the stocking of many fixed regulators.

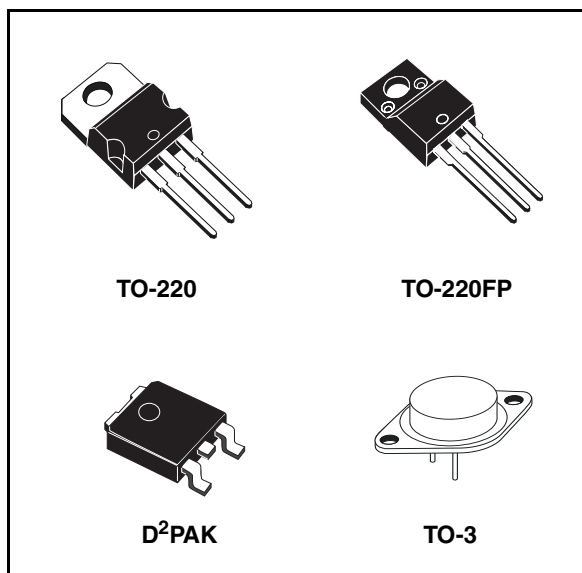

Order code

Part number	Package			
	TO-220	D ² PAK	TO-220FP	TO-3
LM117				LM117K
LM217	LM217T	LM217D2T		LM217K
LM317	LM317T	LM317D2T	LM317P	LM317K

Contents

1	Pin configuration	3
2	Maximum ratings	4
3	Diagram	5
4	Electrical characteristics	6
5	Typical characteristics	8
6	Application information	9
7	Package mechanical data	13
8	Revision history	24

1 Pin configuration

Figure 1. Pin connections (top view)

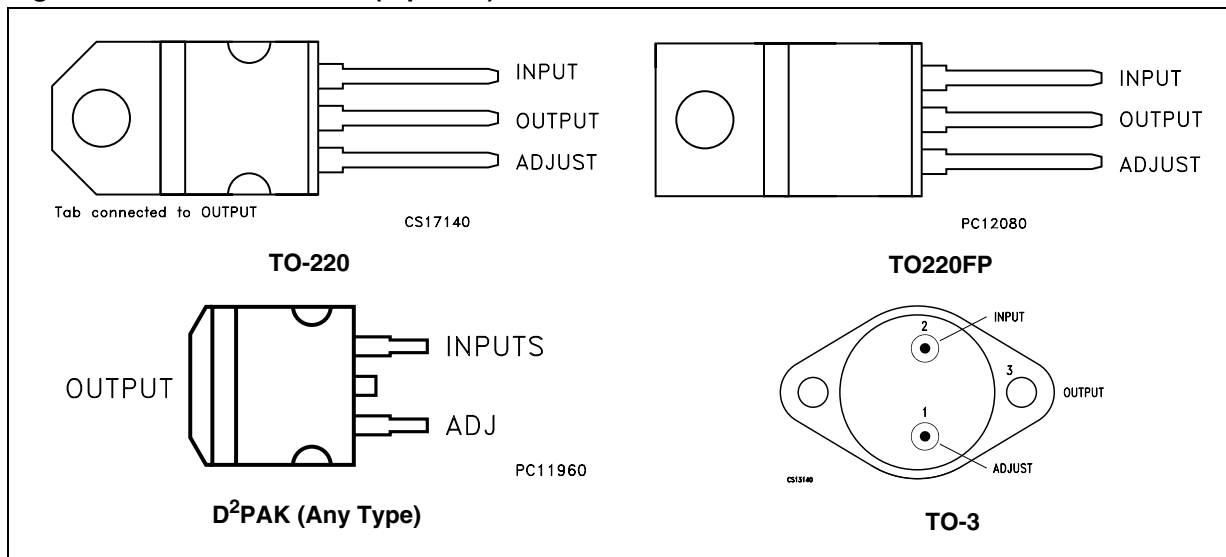

2 Maximum ratings

Table 1. Absolute maximum ratings

Symbol	Parameter	Value	Unit
$V_I - V_O$	Input-Reference Differential Voltage	40	V
I_O	Output Current	Internally Limited	
T_{op}	Operating Junction Temperature for:	LM117	-55 to 150
		LM217	-25 to 150
		LM317	0 to 125
P_{tot}	Power Dissipation	Internally Limited	
T_{stg}	Storage Temperature	-65 to 150	°C

Note: Absolute Maximum Ratings are those values beyond which damage to the device may occur. Functional operation under these condition is not implied

Table 2. Thermal Data

Symbol	Parameter	D ² PAK	TO-220	TO-220FP	TO-3	Unit
R_{thJC}	Thermal resistance junction-case	3	3	5	4	°C/W
R_{thJA}	Thermal resistance junction-ambient	62.5	50	60	35	°C/W

3 Diagram

Figure 2. Schematic diagram

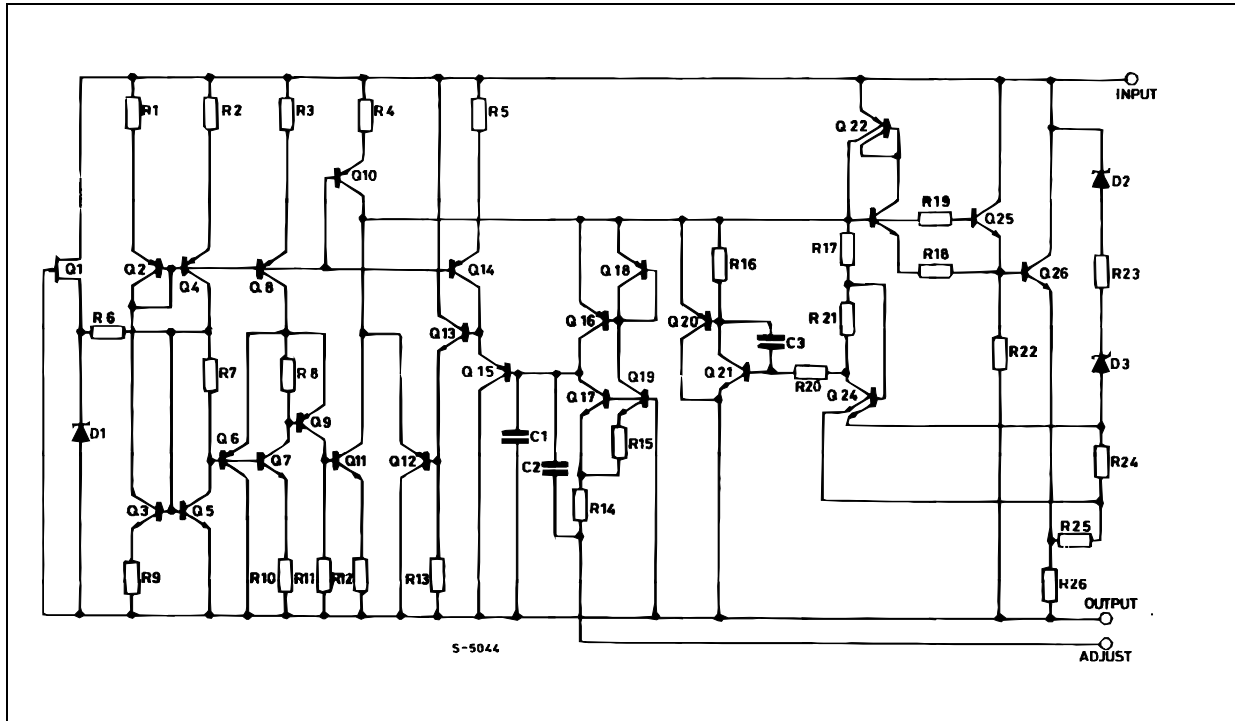

4 Electrical characteristics

Table 3. Electrical characteristics for LM117/LM217 ($V_1 - V_O = 5\text{ V}$, $I_O = 500\text{ mA}$, $I_{MAX} = 1.5\text{ A}$ and $P_{MAX} = 20\text{ W}$, $T_J = -55\text{ to }150^\circ\text{C}$ for LM117, $T_J = -25\text{ to }150^\circ\text{C}$ for LM217, unless otherwise specified)

Symbol	Parameter	Test Conditions		Min.	Typ.	Max.	Unit
ΔV_O	Line regulation	$V_1 - V_O = 3\text{ to }40\text{ V}$	$T_J = 25^\circ\text{C}$		0.01	0.02	%V
					0.02	0.05	
ΔV_O	Load regulation	$V_O \leq 5\text{ V}$ $I_O = 10\text{ mA to }I_{MAX}$	$T_J = 25^\circ\text{C}$		5	15	mV
					20	50	
		$V_O \geq 5\text{ V}$, $I_O = 10\text{ mA to }I_{MAX}$	$T_J = 25^\circ\text{C}$		0.1	0.3	%
					0.3	1	
I_{ADJ}	Adjustment pin current			50	100	μA	
ΔI_{ADJ}	Adjustment pin current	$V_1 - V_O = 2.5\text{ to }40\text{V}$ $I_O = 10\text{ mA to }I_{MAX}$			0.2	5	μA
V_{REF}	Reference voltage (between pin 3 and pin 1)	$V_1 - V_O = 2.5\text{ to }40\text{V}$ $I_O = 10\text{ mA to }I_{MAX}$ $P_D \leq P_{MAX}$		1.2	1.25	1.3	V
$\Delta V_O/V_O$	Output voltage temperature stability				1		%
$I_{O(min)}$	Minimum load current	$V_1 - V_O = 40\text{ V}$			3.5	5	mA
$I_{O(max)}$	Maximum load current	$V_1 - V_O \leq 15\text{ V}$, $P_D < P_{MAX}$		1.5	2.2		A
		$V_1 - V_O = 40\text{ V}$, $P_D < P_{MAX}$, $T_J = 25^\circ\text{C}$			0.4		
eN	Output noise voltage (percentage of V_O)	$B = 10\text{Hz to }100\text{KHz}$, $T_J = 25^\circ\text{C}$			0.003		%
SVR	Supply voltage rejection ⁽¹⁾	$T_J = 25^\circ\text{C}$, $f = 120\text{Hz}$	$C_{ADJ}=0$		65		dB
			$C_{ADJ}=10\mu\text{F}$	66	80		

1. C_{ADJ} is connected between pin 1 and ground.

Table 4. Electrical characteristics for LM317 ($V_I - V_O = 5\text{ V}$, $I_O = 500\text{ mA}$, $I_{MAX} = 1.5\text{ A}$ and $P_{MAX} = 20\text{ W}$, $T_J = 0\text{ to }125^\circ\text{C}$, unless otherwise specified)

Symbol	Parameter	Test Conditions	Min.	Typ.	Max.	Unit	
ΔV_O	Line regulation	$V_I - V_O = 3\text{ to }40\text{ V}$	$T_J = 25^\circ\text{C}$		0.01	0.04	%V
					0.02	0.07	
ΔV_O	Load regulation	$V_O \leq 5\text{ V}$ $I_O = 10\text{ mA to }I_{MAX}$	$T_J = 25^\circ\text{C}$		5	25	mV
					20	70	
		$V_O \geq 5\text{ V}$, $I_O = 10\text{ mA to }I_{MAX}$	$T_J = 25^\circ\text{C}$		0.1	0.5	%
					0.3	1.5	
I_{ADJ}	Adjustment pin current			50	100	μA	
ΔI_{ADJ}	Adjustment pin current	$V_I - V_O = 2.5\text{ to }40\text{ V}$ $I_O = 10\text{ mA to }I_{MAX}$		0.2	5	μA	
V_{REF}	Reference voltage (between pin 3 and pin 1)	$V_I - V_O = 2.5\text{ to }40\text{ V}$ $I_O = 10\text{ mA to }I_{MAX}$ $P_D \leq P_{MAX}$	1.2	1.25	1.3	V	
$\Delta V_O/V_O$	Output voltage temperature stability			1		%	
$I_{O(min)}$	Minimum load current	$V_I - V_O = 40\text{ V}$		3.5	10	mA	
$I_{O(max)}$	Maximum load current	$V_I - V_O \leq 15\text{ V}$, $P_D < P_{MAX}$	1.5	2.2		A	
		$V_I - V_O = 40\text{ V}$, $P_D < P_{MAX}$, $T_J = 25^\circ\text{C}$		0.4			
eN	Output noise voltage (percentage of V_O)	$B = 10\text{ Hz to }100\text{ KHz}$, $T_J = 25^\circ\text{C}$		0.003		%	
SVR	Supply voltage rejection ⁽¹⁾	$T_J = 25^\circ\text{C}$, $f = 120\text{ Hz}$	$C_{ADJ}=0$		65	dB	
			$C_{ADJ}=10\mu\text{F}$	66	80		

1. C_{ADJ} is connected between pin 1 and ground.

5 Typical characteristics

Figure 3. Output current vs input-output differential voltage

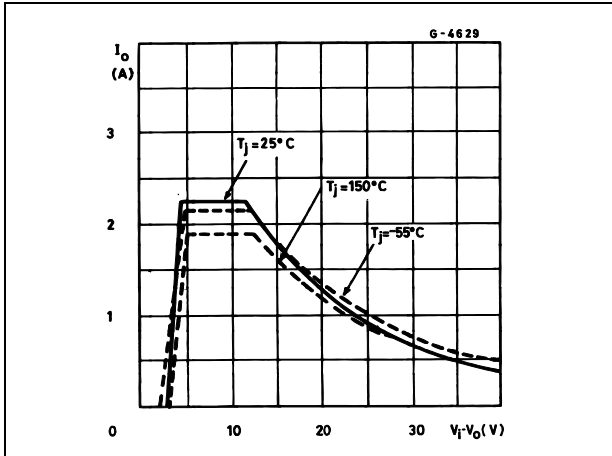

Figure 4. Dropout voltage vs junction temperature

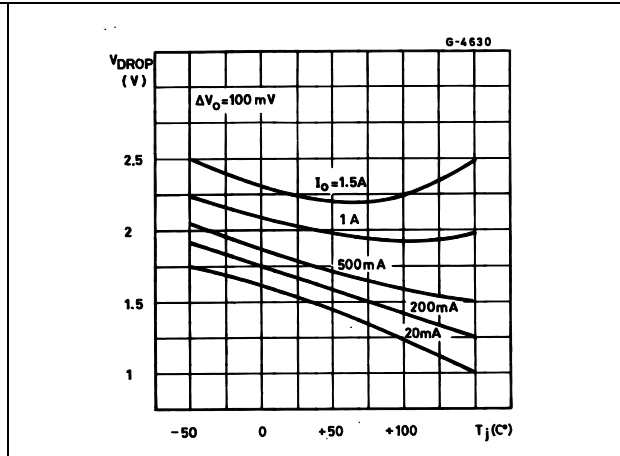

Figure 5. Reference voltage vs junction

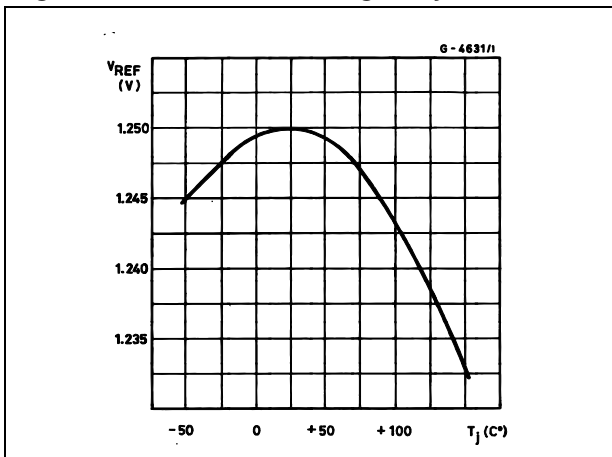
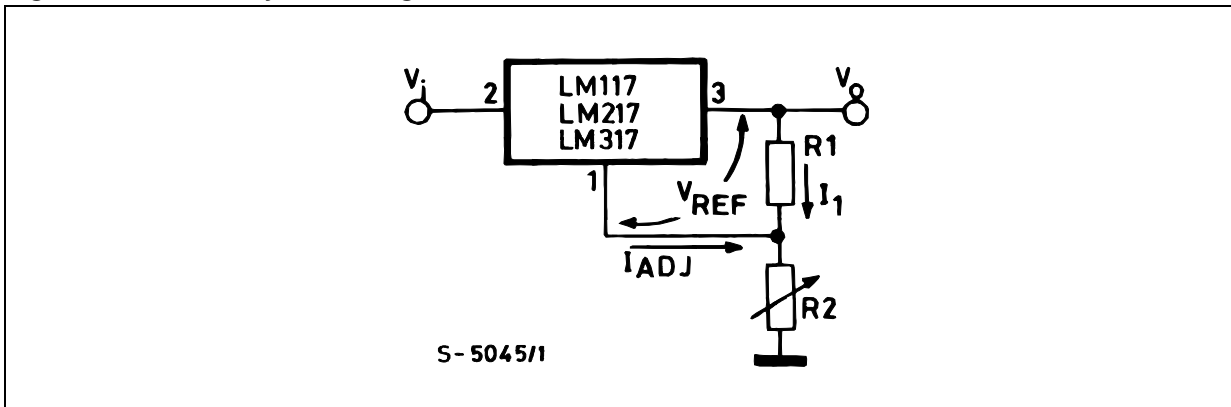

Figure 6. Basic adjustable regulator



6 Application information

The LM117/217/317 provides an internal reference voltage of 1.25V between the output and adjustments terminals. This is used to set a constant current flow across an external resistor divider (see [Figure 3.](#)), giving an output voltage V_O of:

$$V_O = V_{REF} (1 + R_2/R_1) + I_{ADJ} R_2$$

The device was designed to minimize the term I_{ADJ} (100 μ A max) and to maintain it very constant with line and load changes. Usually, the error term $I_{ADJ} \times R_2$ can be neglected. To obtain the previous requirement, all the regulator quiescent current is returned to the output terminal, imposing a minimum load current condition. If the load is insufficient, the output voltage will rise. Since the LM117/217/317 is a floating regulator and "sees" only the input-to-output differential voltage, supplies of very high voltage with respect to ground can be regulated as long as the maximum input-to-output differential is not exceeded. Furthermore, programmable regulators are easily obtainable and, by connecting a fixed resistor between the adjustment and output, the device can be used as a precision current regulator. In order to optimize the load regulation, the current set resistor R_1 (see [Figure 3.](#)) should be tied as close as possible to the regulator, while the ground terminal of R_2 should be near the ground of the load to provide remote ground sensing. Performance may be improved with added capacitance as follows:

An input bypass capacitor of 0.1 μ F

An adjustment terminal to ground 10 μ F capacitor to improve the ripple rejection of about 15 dB (CADJ).

An 1 μ F tantalum (or 25 μ F Aluminium electrolytic) capacitor on the output to improve transient response. In addition to external capacitors, it is good practice to add protection diodes, as shown in [Figure 4.](#) D1 protect the device against input short circuit, while D2 protect against output short circuit for capacitance discharging.

Figure 7. Voltage regulator with protection diodes

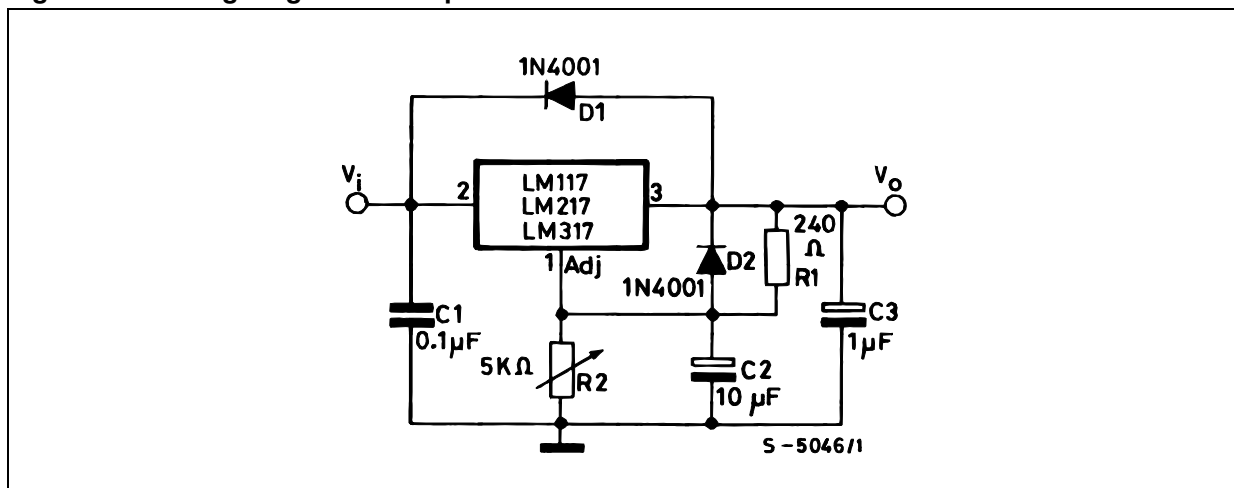

Note: D1 protect the device against input short circuit, while D2 protects against output short circuit for capacitors discharging.

Figure 8. Slow Turn-on 15V Regulator

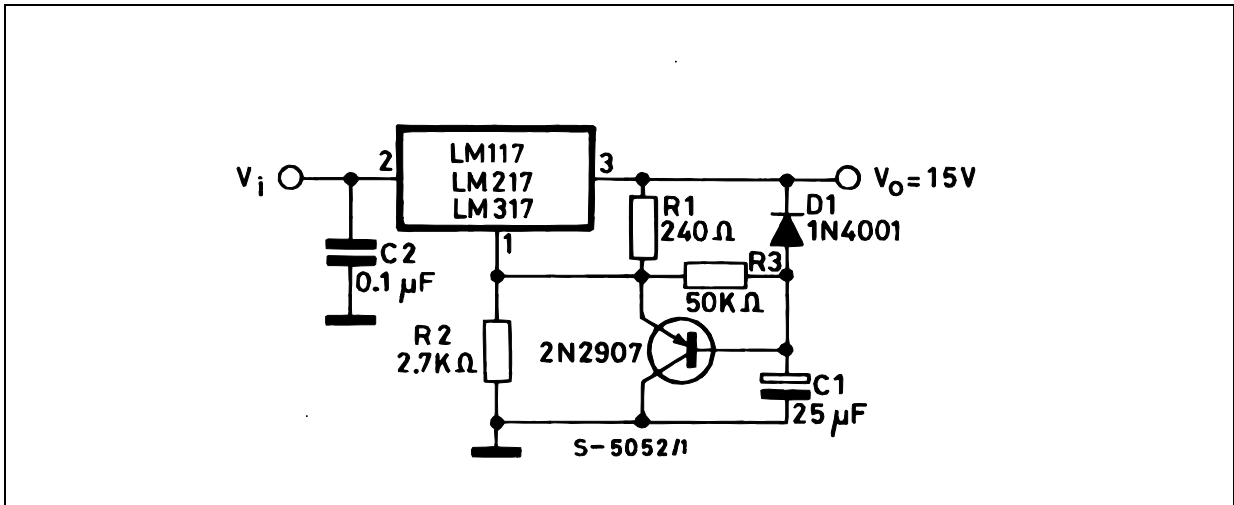

Figure 9. Current regulator

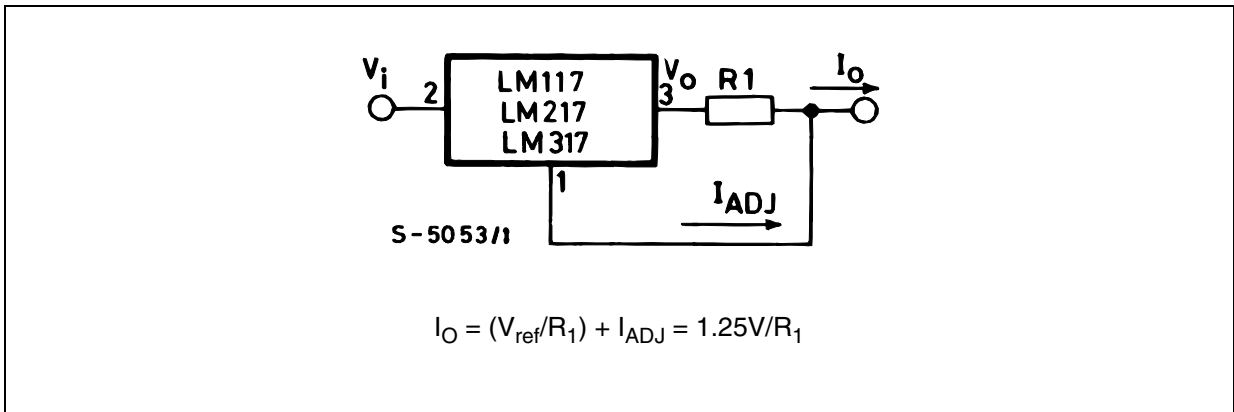

Figure 10. 5V Electronic shut-down regulator

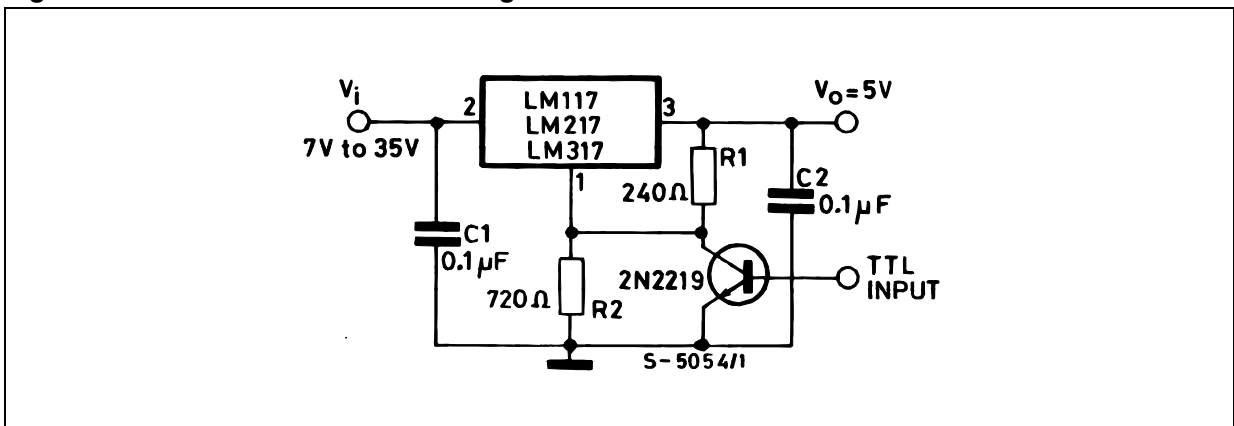
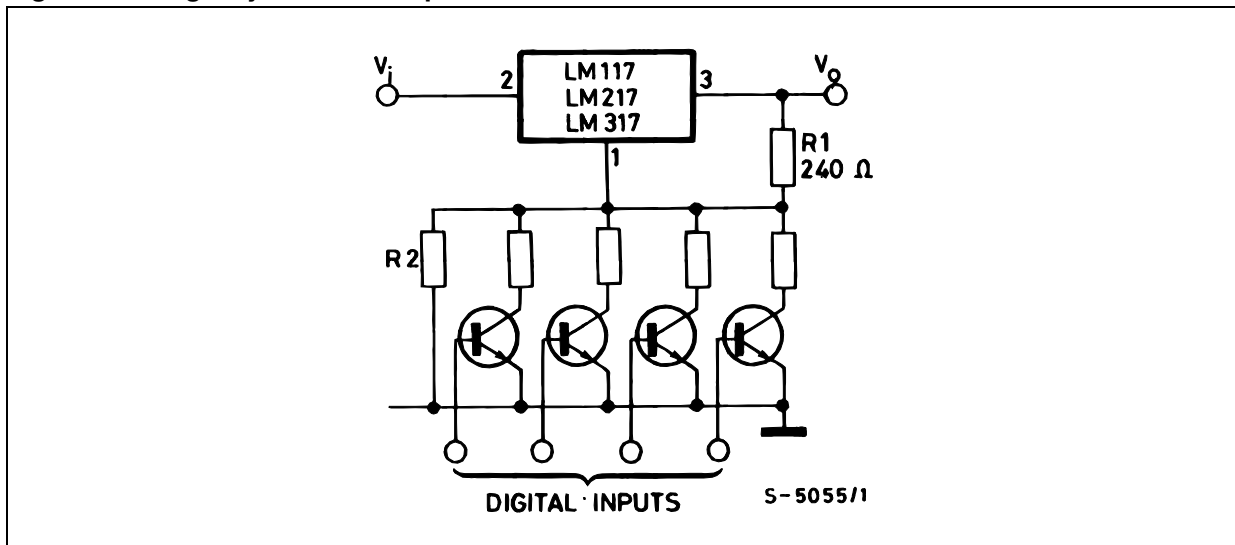
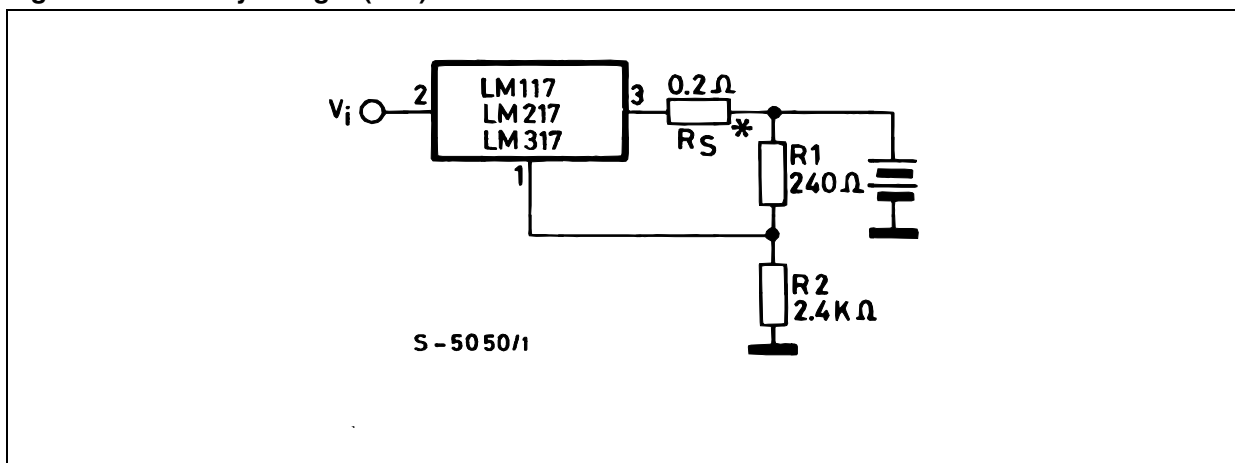

Figure 11. Digitally selected outputs



(R_2 sets maximum V_O)

Figure 12. Battery charger (12V)



* R_S sets output impedance of charger $Z_O = R_S (1 + R_2/R_1)$. Use of R_S allows low charging rates whit fully charged battery.

Figure 13. Current limited 6V Charger

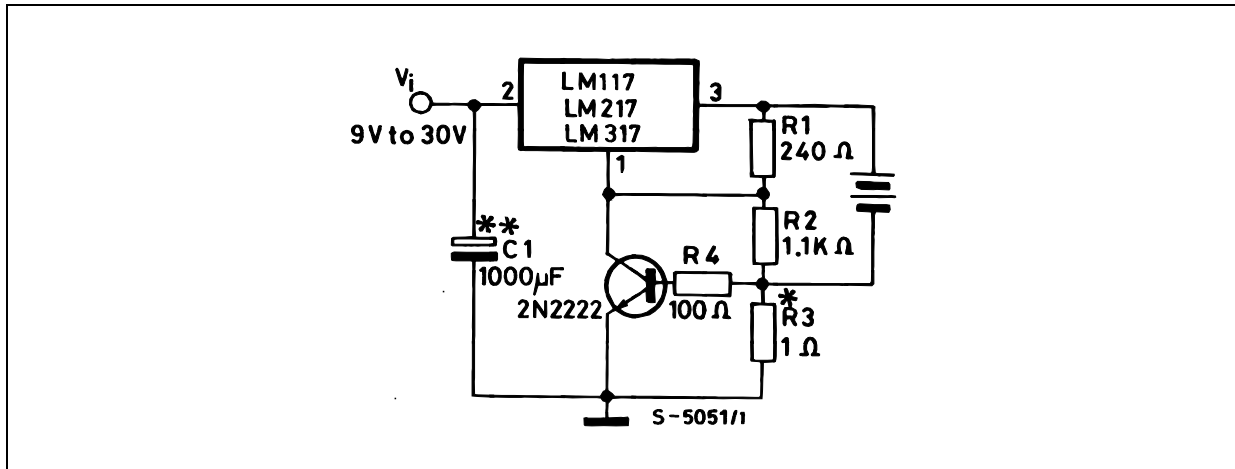

* R3 sets peak current (0.6A for 1 Ω).

** C1 recommended to filter out input transients.

7 Package mechanical data

In order to meet environmental requirements, ST offers these devices in ECOPACK® packages. These packages have a Lead-free second level interconnect. The category of second Level Interconnect is marked on the package and on the inner box label, in compliance with JEDEC Standard JESD97. The maximum ratings related to soldering conditions are also marked on the inner box label. ECOPACK is an ST trademark. ECOPACK specifications are available at: www.st.com.

TO-3 MECHANICAL DATA

DIM.	mm.			inch		
	MIN.	TYP	MAX.	MIN.	TYP.	MAX.
A		11.85			0.466	
B	0.96	1.05	1.10	0.037	0.041	0.043
C			1.70			0.066
D			8.7			0.342
E			20.0			0.787
G		10.9			0.429	
N		16.9			0.665	
P			26.2			1.031
R	3.88		4.09	0.152		0.161
U			39.5			1.555
V		30.10			1.185	

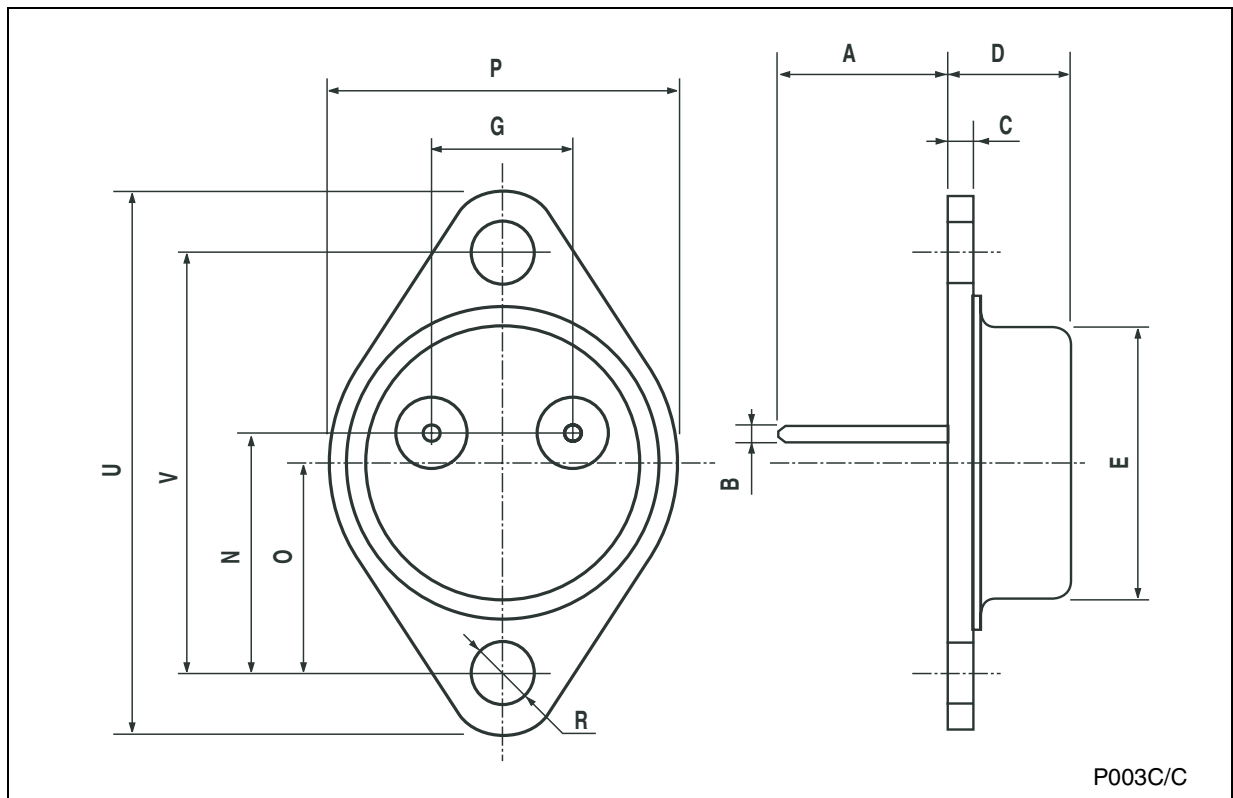

P003C/C

TO-220 (A TYPE) MECHANICAL DATA

DIM.	mm.			inch		
	MIN.	TYP	MAX.	MIN.	TYP.	MAX.
A	4.40		4.60	0.173		0.181
b	0.61		0.88	0.024		0.034
b1	1.15		1.70	0.045		0.067
c	0.49		0.70	0.019		0.027
D	15.25		15.75	0.600		0.620
E	10.0		10.40	0.393		0.409
e	2.4		2.7	0.094		0.106
e1	4.95		5.15	0.194		0.203
F	1.23		1.32	0.048		0.051
H1	6.2		6.6	0.244		0.260
J1	2.40		2.72	0.094		0.107
L	13.0		14.0	0.511		0.551
L1	3.5		3.93	0.137		0.154
L20		16.4			0.645	
L30		28.9			1.138	
φP	3.75		3.85	0.147		0.151
Q	2.65		2.95	0.104		0.116

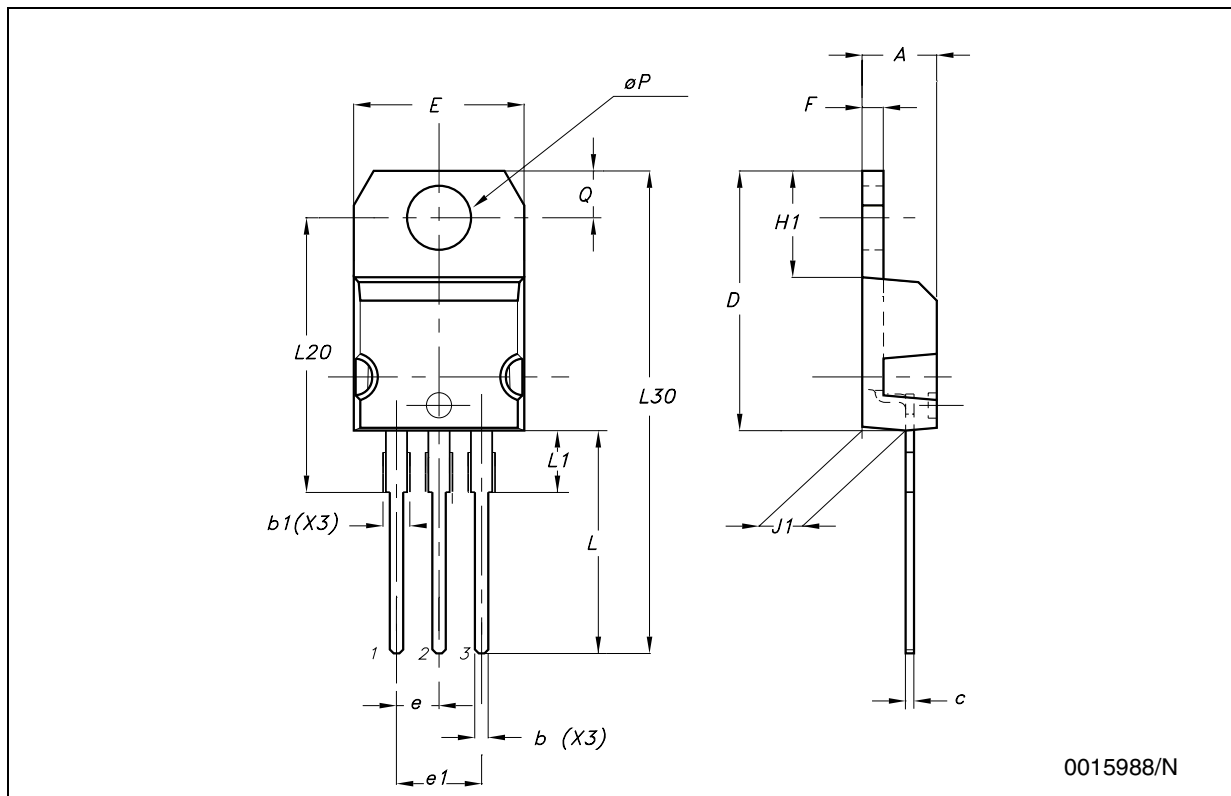

TO-220 (C TYPE) MECHANICAL DATA

DIM.	mm.			inch		
	MIN.	TYP	MAX.	MIN.	TYP.	MAX.
A	4.30		4.70	0.169		0.185
b	0.70		0.90	0.028		0.035
b1	1.42		1.62	0.056		0.064
c	0.45		0.60	0.018		0.024
D		15.70			0.618	
E	9.80		10.20	0.386		0.402
e		2.54			0.100	
e1		5.08			0.200	
F	1.25		1.39	0.049		0.055
H1		6.5			0.256	
J1	2.20		2.60	0.087		0.202
L	12.88		13.28	0.507		0.523
L1		3			0.118	
L20	15.70		16.1	0.618		0.634
L30		28.9			1.138	
φP	3.50		3.70	0.138		0.146
Q	2.70		2.90	0.106		0.114

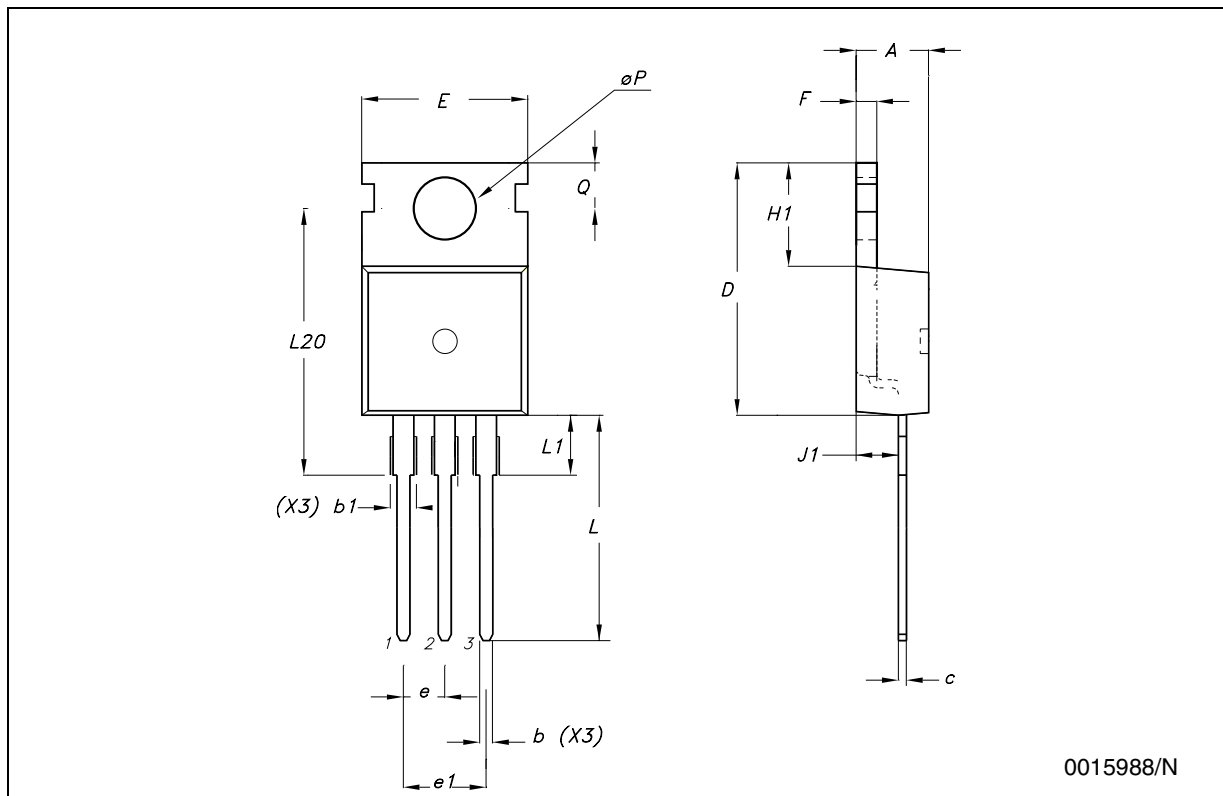

0015988/N

TO-220 (E TYPE) MECHANICAL DATA

DIM.	mm.			inch		
	MIN.	TYP	MAX.	MIN.	TYP.	MAX.
A	4.47		4.67	0.176		0.184
b	0.70		0.91	0.028		0.036
b1	1.17		1.37	0.046		0.054
c	0.31		0.53	0.012		0.021
D	14.60		15.70	0.575		0.618
E	9.96		10.36	0.392		0.408
e		2.54			0.100	
e1		5.08			0.200	
F	1.17		1.37	0.046		0.054
H1	6.1		6.8	0.240		0.268
J1	2.52		2.82	0.099		0.111
L	12.70		13.80	0.500		0.543
L1	3.20		3.96	0.126		0.156
L20	15.21		16.77	0.599		0.660
ϕP	3.73		3.94	0.147		0.155
Q	2.59		2.89	0.102		0.114

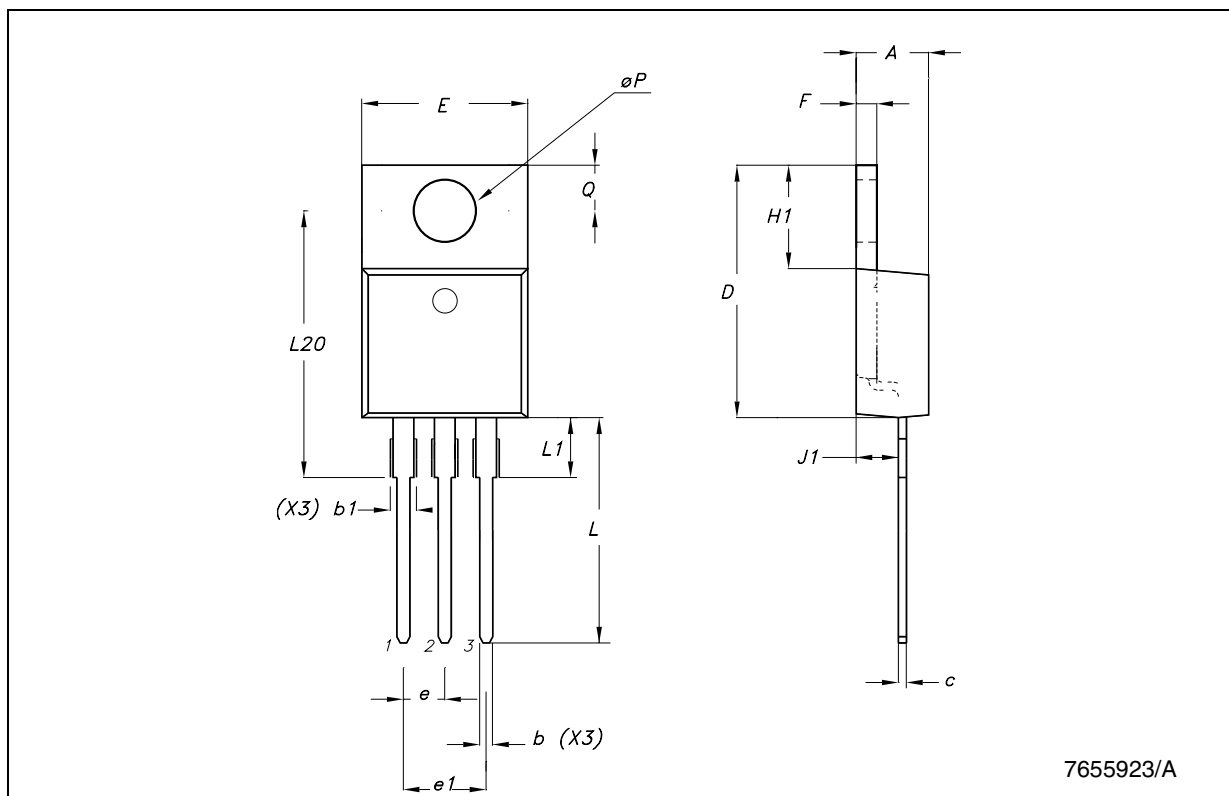

TO-220FP MECHANICAL DATA

DIM.	mm.			inch		
	MIN.	TYP	MAX.	MIN.	TYP.	MAX.
A	4.40		4.60	0.173		0.181
B	2.5		2.7	0.098		0.106
D	2.5		2.75	0.098		0.108
E	0.45		0.70	0.017		0.027
F	0.75		1	0.030		0.039
F1	1.15		1.50	0.045		0.059
F2	1.15		1.50	0.045		0.059
G	4.95		5.2	0.194		0.204
G1	2.4		2.7	0.094		0.106
H	10.0		10.40	0.393		0.409
L2		16			0.630	
L3	28.6		30.6	1.126		1.204
L4	9.8		10.6	0.385		0.417
L5	2.9		3.6	0.114		0.142
L6	15.9		16.4	0.626		0.645
L7	9		9.3	0.354		0.366
DIA.	3		3.2	0.118		0.126

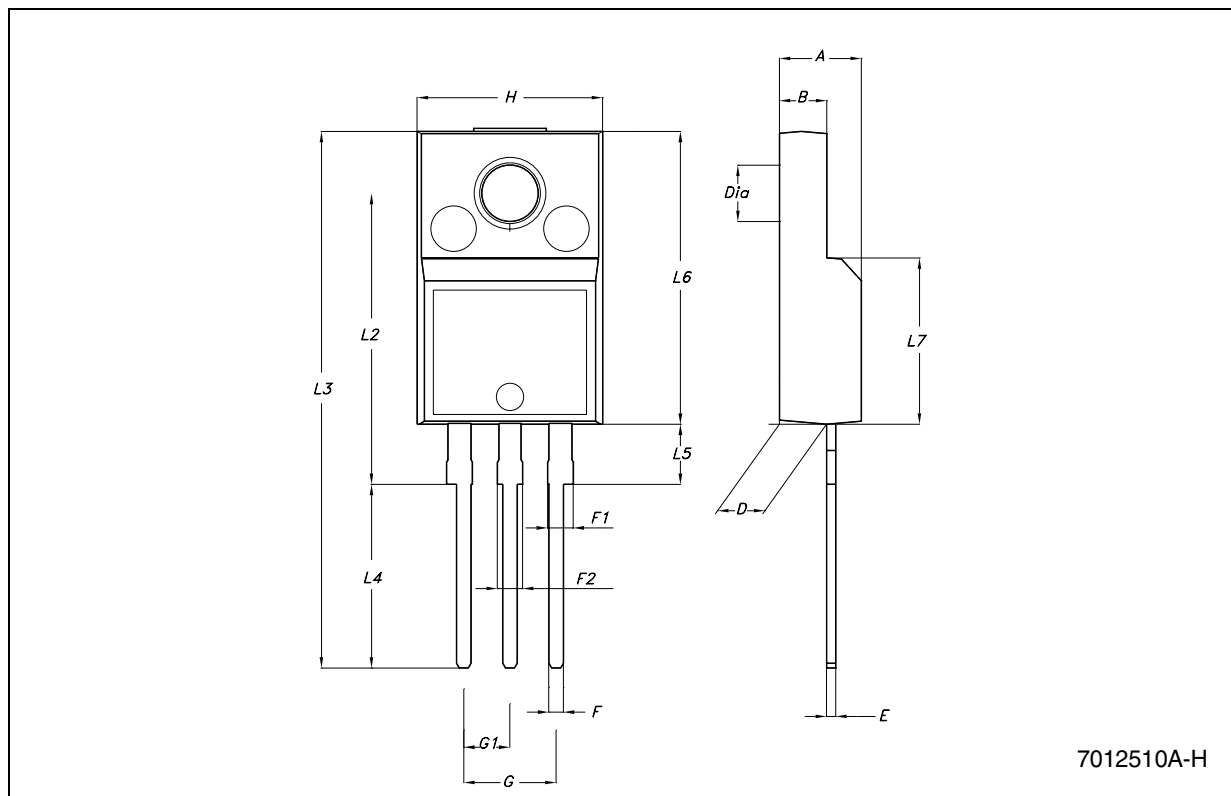

Figure 14. DRAWING DIMENSION D²PAK (TYPE STD-ST)

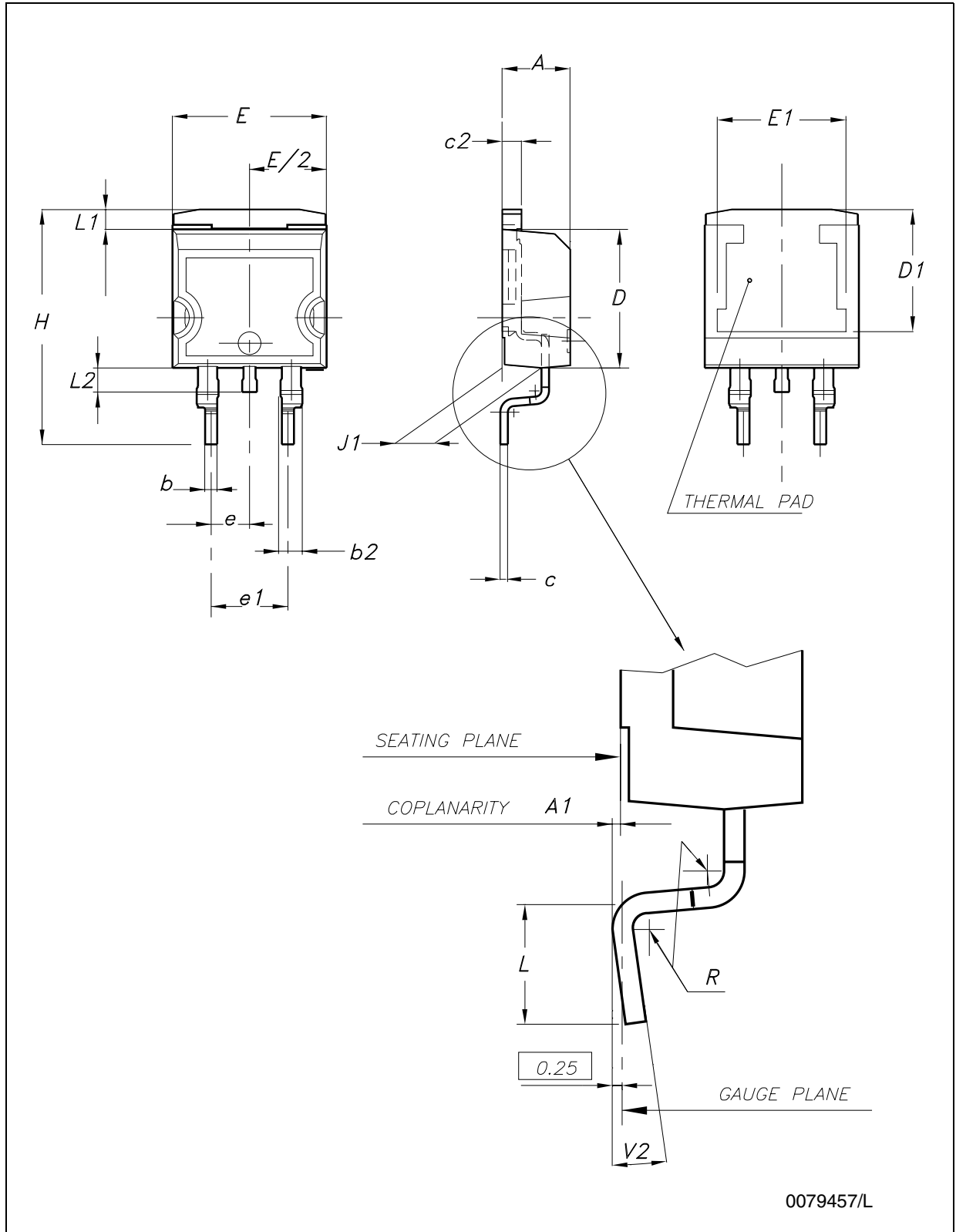
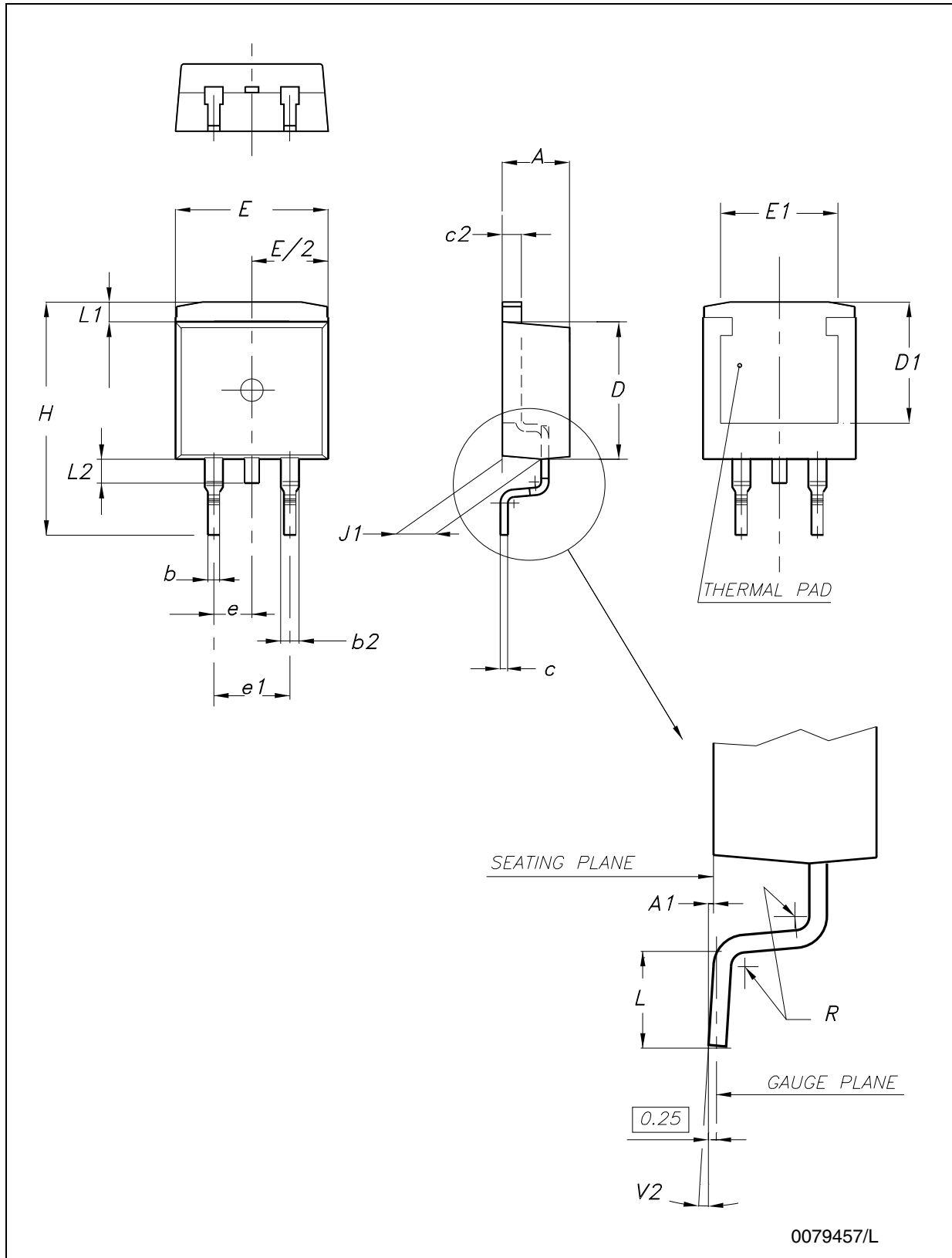

Figure 15. DRAWING DIMENSION D²PAK (TYPE WOOSEOK-SUBCON.)



0079457/L

Table 5. D²PAK MECHANICAL DATA

DIM.	TYPE STD-ST			TYPE WOOSEOK-SUBCON.		
	mm.			mm.		
	MIN.	TYP.	MAX.	MIN.	TYP.	MAX.
A	4.40		4.60	4.30		4.70
A1	0.03		0.23	0		0.20
b	0.70		0.93	0.70		0.90
b2	1.14		1.70	1.17		1.37
c	0.45		0.60	0.45	0.50	0.60
c2	1.23		1.36	1.25	1.30	1.40
D	8.95		9.35	9	9.20	9.40
D1	7.50			7.50		
E	10		10.40	9.80		10.20
E1	8.50			7.50		
e		2.54			2.54	
e1	4.88		5.28		5.08	
H	15		15.85	15	15.30	15.60
J1	2.49		2.69	2.20		2.60
L	2.29		2.79	1.79		2.79
L1	1.27		1.40	1		1.40
L2	1.30		1.75	1.20		1.60
R		0.4			0.30	
V2	0°		8°	0°		3°

Note: The D²PAK package coming from the subcontractor Wooseok is fully compatible with the ST's package suggested footprint.

Figure 16. D²PAK FOOTPRINT RECOMMENDED DATA

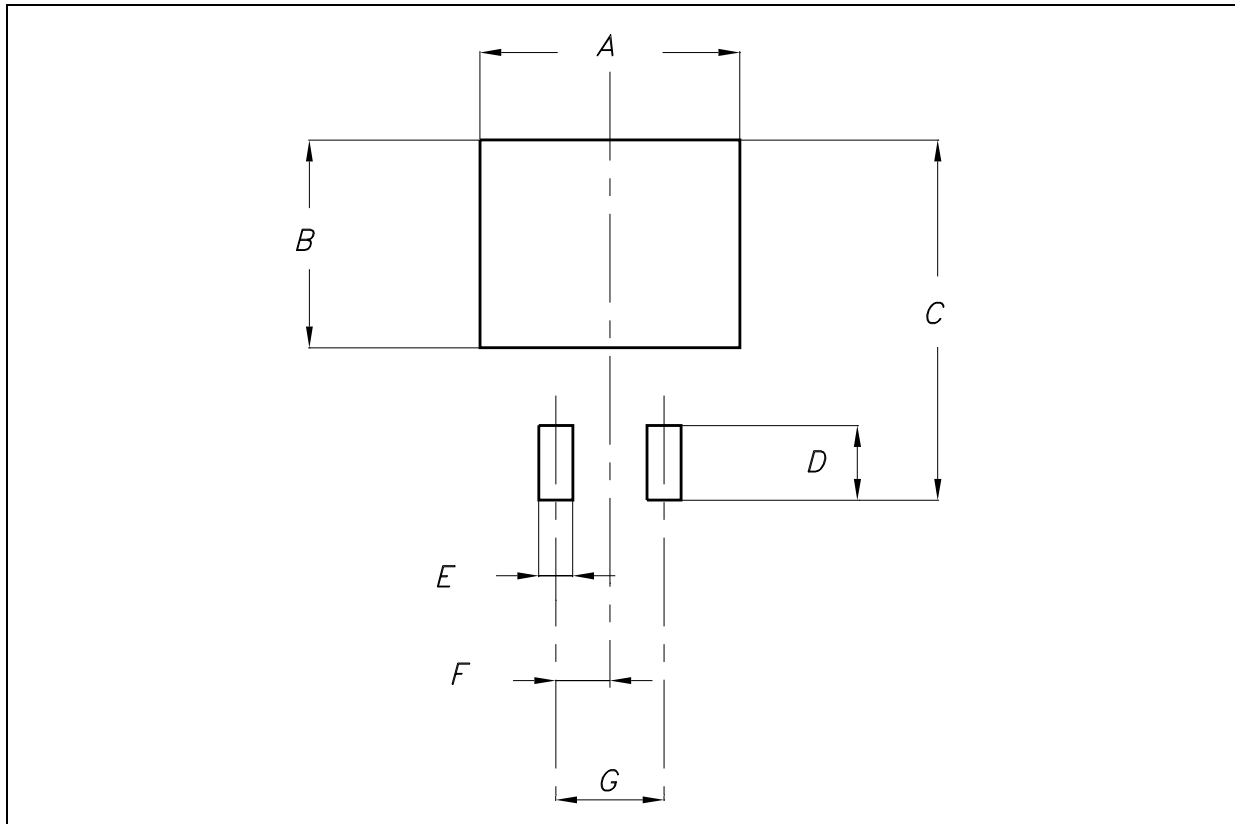
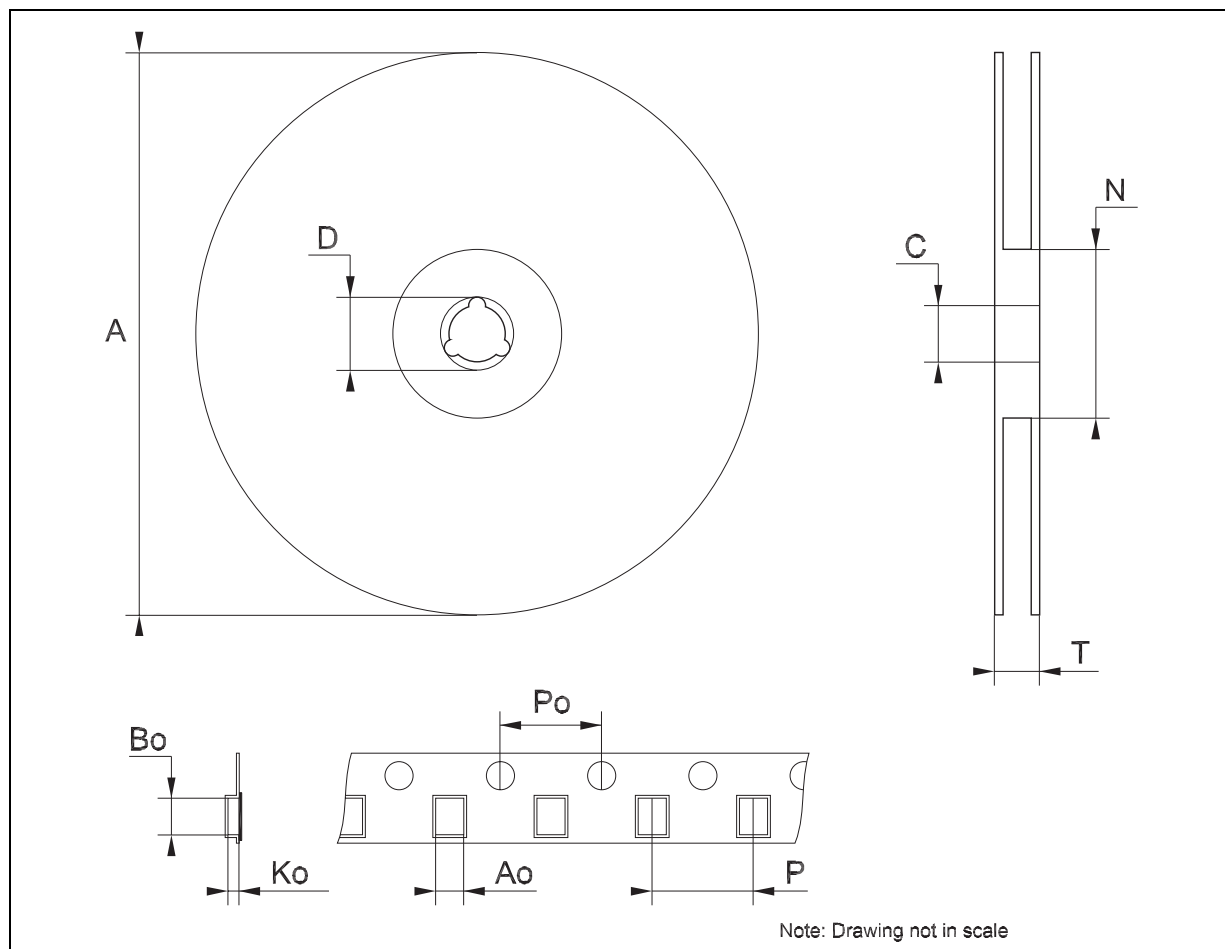

Table 6. FOOTPRINT DATA

VALUES		
	mm.	inch.
A	12.20	0.480
B	9.75	0.384
C	16.90	0.665
D	3.50	0.138
E	1.60	0.063
F	2.54	0.100
G	5.08	0.200

Tape & Reel D²PAK-P²PAK-D²PAK/A-P²PAK/A MECHANICAL DATA

DIM.	mm.			inch		
	MIN.	TYP	MAX.	MIN.	TYP.	MAX.
A			180			7.086
C	12.8	13.0	13.2	0.504	0.512	0.519
D	20.2			0.795		
N	60			2.362		
T			14.4			0.567
Ao	10.50	10.6	10.70	0.413	0.417	0.421
Bo	15.70	15.80	15.90	0.618	0.622	0.626
Ko	4.80	4.90	5.00	0.189	0.193	0.197
Po	3.9	4.0	4.1	0.153	0.157	0.161
P	11.9	12.0	12.1	0.468	0.472	0.476



8 Revision history

Table 7. Revision history

Date	Revision	Changes
01-Sep-2004	10	Mistake $V_{REF} \Rightarrow V_O$, tables 1, 4 and 5.
19-Jan-2007	11	D ² PAK mechanical data has been updated, add footprint data and the document has been reformatted.

Please Read Carefully:

Information in this document is provided solely in connection with ST products. STMicroelectronics NV and its subsidiaries ("ST") reserve the right to make changes, corrections, modifications or improvements, to this document, and the products and services described herein at any time, without notice.

All ST products are sold pursuant to ST's terms and conditions of sale.

Purchasers are solely responsible for the choice, selection and use of the ST products and services described herein, and ST assumes no liability whatsoever relating to the choice, selection or use of the ST products and services described herein.

No license, express or implied, by estoppel or otherwise, to any intellectual property rights is granted under this document. If any part of this document refers to any third party products or services it shall not be deemed a license grant by ST for the use of such third party products or services, or any intellectual property contained therein or considered as a warranty covering the use in any manner whatsoever of such third party products or services or any intellectual property contained therein.

UNLESS OTHERWISE SET FORTH IN ST'S TERMS AND CONDITIONS OF SALE ST DISCLAIMS ANY EXPRESS OR IMPLIED WARRANTY WITH RESPECT TO THE USE AND/OR SALE OF ST PRODUCTS INCLUDING WITHOUT LIMITATION IMPLIED WARRANTIES OF MERCHANTABILITY, FITNESS FOR A PARTICULAR PURPOSE (AND THEIR EQUIVALENTS UNDER THE LAWS OF ANY JURISDICTION), OR INFRINGEMENT OF ANY PATENT, COPYRIGHT OR OTHER INTELLECTUAL PROPERTY RIGHT.

UNLESS EXPRESSLY APPROVED IN WRITING BY AN AUTHORIZED ST REPRESENTATIVE, ST PRODUCTS ARE NOT RECOMMENDED, AUTHORIZED OR WARRANTED FOR USE IN MILITARY, AIR CRAFT, SPACE, LIFE SAVING, OR LIFE SUSTAINING APPLICATIONS, NOR IN PRODUCTS OR SYSTEMS WHERE FAILURE OR MALFUNCTION MAY RESULT IN PERSONAL INJURY, DEATH, OR SEVERE PROPERTY OR ENVIRONMENTAL DAMAGE. ST PRODUCTS WHICH ARE NOT SPECIFIED AS "AUTOMOTIVE GRADE" MAY ONLY BE USED IN AUTOMOTIVE APPLICATIONS AT USER'S OWN RISK.

Resale of ST products with provisions different from the statements and/or technical features set forth in this document shall immediately void any warranty granted by ST for the ST product or service described herein and shall not create or extend in any manner whatsoever, any liability of ST.

ST and the ST logo are trademarks or registered trademarks of ST in various countries.

Information in this document supersedes and replaces all information previously supplied.

The ST logo is a registered trademark of STMicroelectronics. All other names are the property of their respective owners.

© 2007 STMicroelectronics - All rights reserved

STMicroelectronics group of companies

Australia - Belgium - Brazil - Canada - China - Czech Republic - Finland - France - Germany - Hong Kong - India - Israel - Italy - Japan - Malaysia - Malta - Morocco - Singapore - Spain - Sweden - Switzerland - United Kingdom - United States of America

www.st.com